

ENGINEERING
TOMORROW

Danfoss

Quick Setup Guide

AK-System Manager

AK-SM 800

ADAP-KOOL® Refrigeration Control System



ЮГОВ - Проект

інженерно-виробниче підприємство

Офіційний дистриб'ютор
Danfoss в Україні



ugov.ua

Contents

| | |
|---|-----------|
| Document History | 3 |
| Mounting Specifications | 4 |
| Installation | 5 |
| Connections | 7 |
| Network topology | 7 |
| Remote Management Tool (RMT)..... | 10 |
| Initial Configuration - language | 12 |
| Initial Configuration - Wizard | 13 |
| Configuration..... | 16 |
| Service Tool Support | 34 |
| General navigation, operation and use (via web)..... | 35 |
| Connecting to your AK-SM:..... | 35 |
| Dashboard view: | 35 |
| Managing alarms: | 36 |
| Device detail:..... | 37 |
| System view:..... | 38 |
| Schedule view:..... | 39 |
| History (Logs)..... | 40 |
| Collecting and viewing history..... | 41 |
| Updating Software (via USB Flash Drive) | 42 |

Document History

Document revision

| Document | Notes |
|------------------|------------------------|
| USCO.PI.R1.H1.02 | First document release |
| | |

Mounting Specifications

The mounting location should be flat, dry and free of major vibrations. The AK-SM 800 should be mounted at eye level.

Dimensions:

Unit Width 295 mm (11.6")

Unit Height 235 mm (9.3")

Unit Depth 65 mm (2.5")

Mounting holes 246 mm (9.7") Width

Mounting holes 175 mm (6.9") Height

Operating temperature:

Screen: -10 to +55°C (14 to 131°F)

@ 90% RH (non condensing)

Electrical range: ~ 100 - 240 V a.c. (+ / - 10%) 50/60 Hz

Built in alarm relay 240 V a.c. Class II 3 Amp inductive, 5 Amp.

ohmic

Approvals: CE

IP 20

USB Access door

Active USB Flash drive (use for load/save database and AK-SM software)

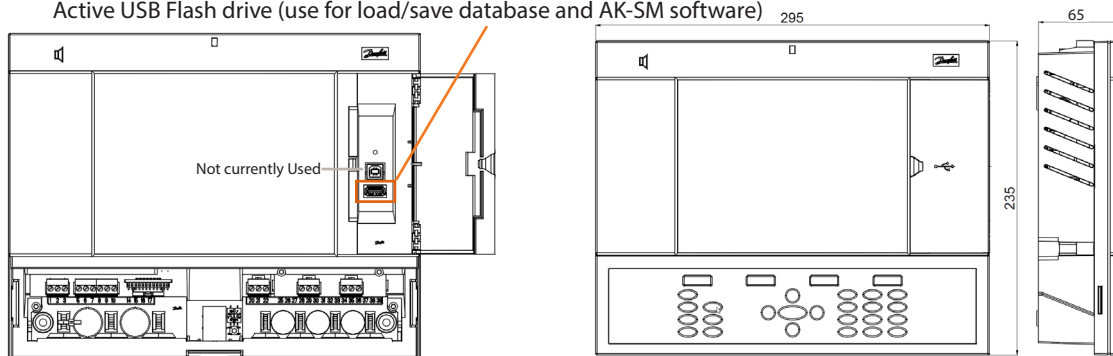

WARNING: To avoid risk of injury from electric shock, ensure correct electrical isolation is made before working within the enclosure.

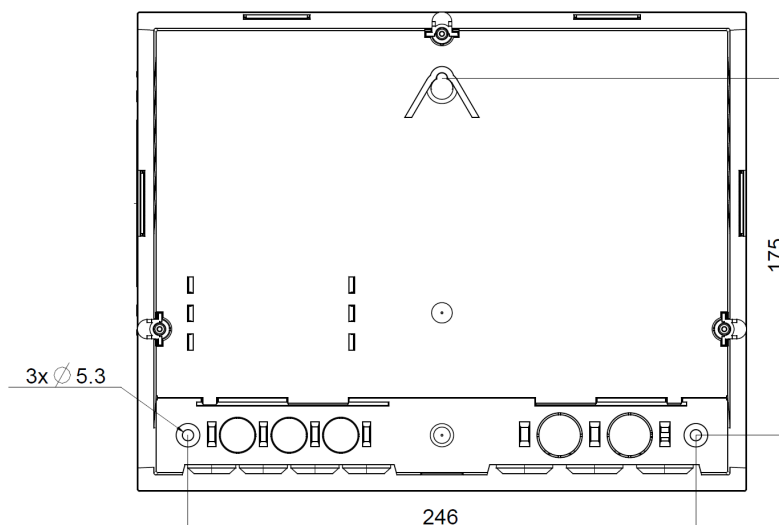

Installation

Tools needed

- Bubble level
- Small slotted screwdriver for connector screws
- Torx 8 screwdriver for releasing the electronic unit and for fastening the unit when recessed mounted
- Screwdriver for fixing the AK-SM 800
- Pen for marking the 2 lower fixation holes
- Larger slotted screwdriver for releasing the Technician lid

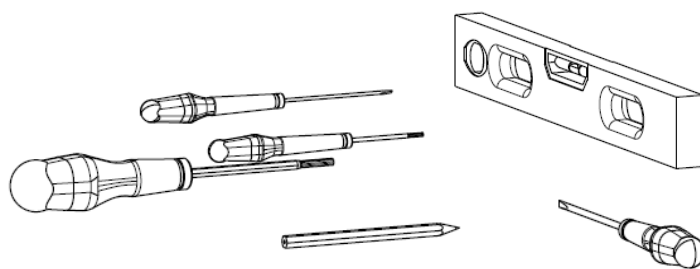

Wall Mounting- box

- Attach screw to the wall
- Mount AK-SM 800 to the screw
- Loosen Technician lid (three sides)
- Remove Technician lid
- Level the AK-SM 800
- If drilling is necessary, mark up 2 screws in Connector part.
- Attach the Connector part to the wall using another 2 screws

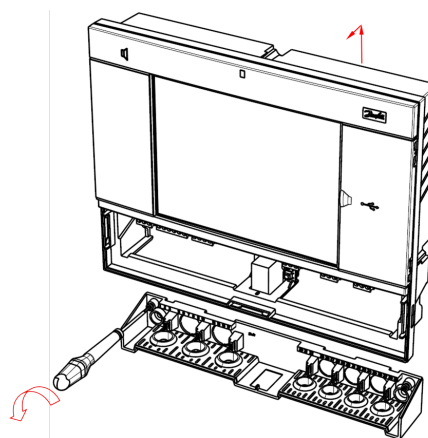
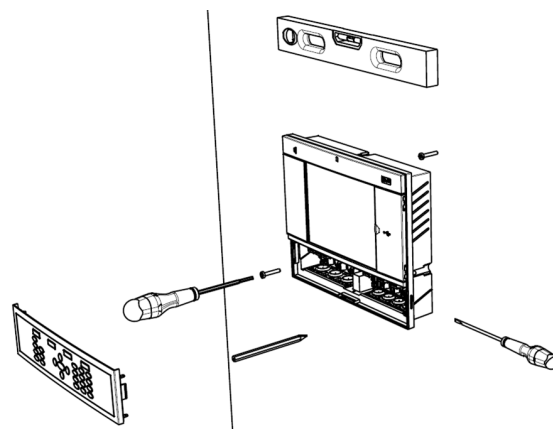

Wall Mounting- wiring

- Insert cables through the rubber grommets

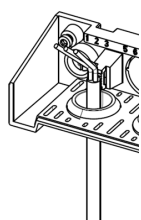
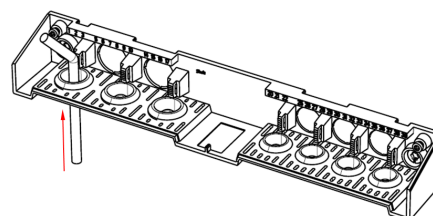

Strip the cables

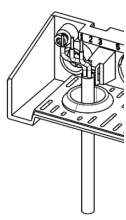

Strip the wires

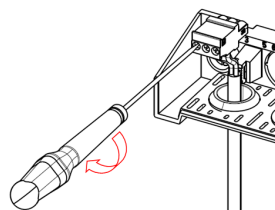

Secure wires in connectors by screwdriver

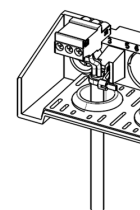

Strain relief the cables

Carefully replace the keypad, ensure that it securely snaps into place

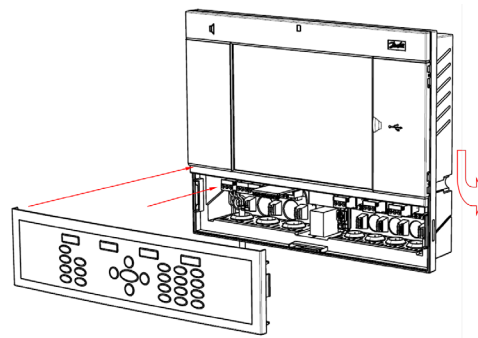

Wall Mounting- Panel recessed

From the front:

A hole of the size 280 x 220 mm is machined

The AK-SM 800 is inserted in the hole

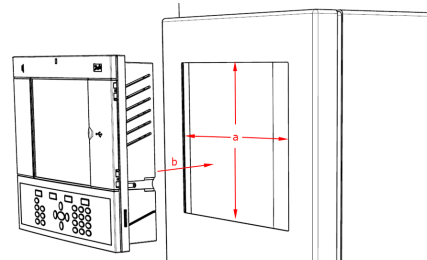

From the backside:

Slide the 3 fastener into the housing part

The screws are inserted into the fasteners

Secure the unit by tightening the screws

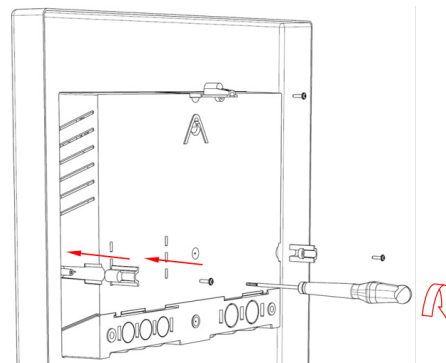

Remove Technician lid

From the back, push cables inside the housing

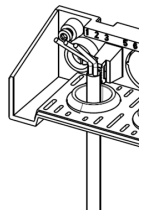
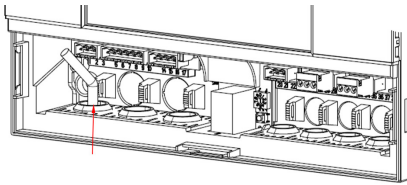

Strip the cables

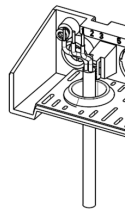

Strip the wires

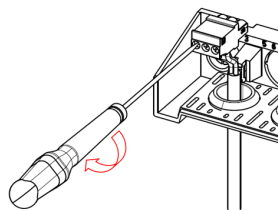

Secure wires in connectors by screwdriver

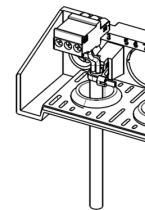

Strain relief the cables

Carefully replace the keypad, ensure that it securely snaps into place

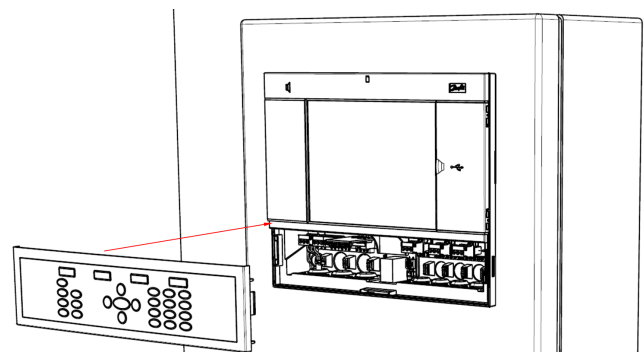

Connections

The following chapter describes the available connections on your AK-SM 800.



Please note that not all connection points are currently active, please refer to the drawing below for more details

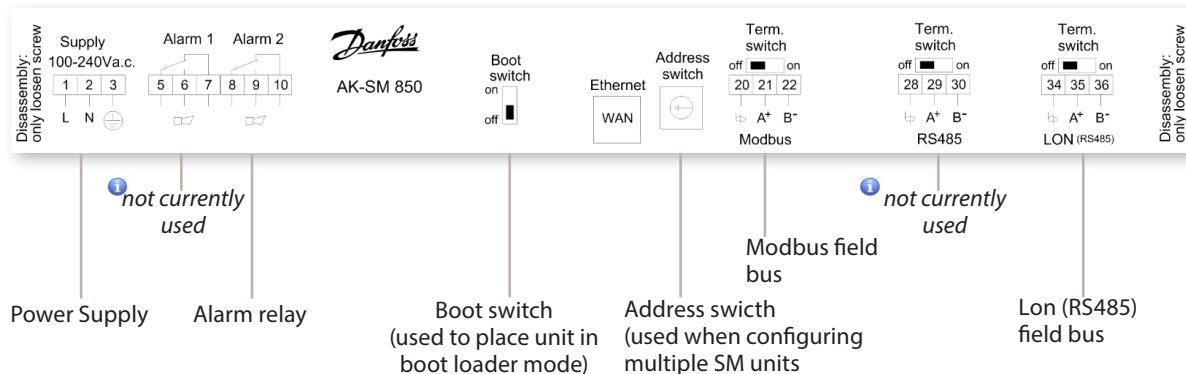

RJ 45 LAN, Use shielded Ethernet cable

Network topology

Your AK-SM supports both Modbus and Lon RS485 local bus connections. For further detailed description of network connections please refer to document 'Data Communication between ADAP-KOOL® Refrigeration controllers_RC8AC602' Lon RS485

Follow standard topology guidelines for Lon RS485, with particular respect to maximum cable length, when to use a repeater and ensuring suitable resistors are in place.

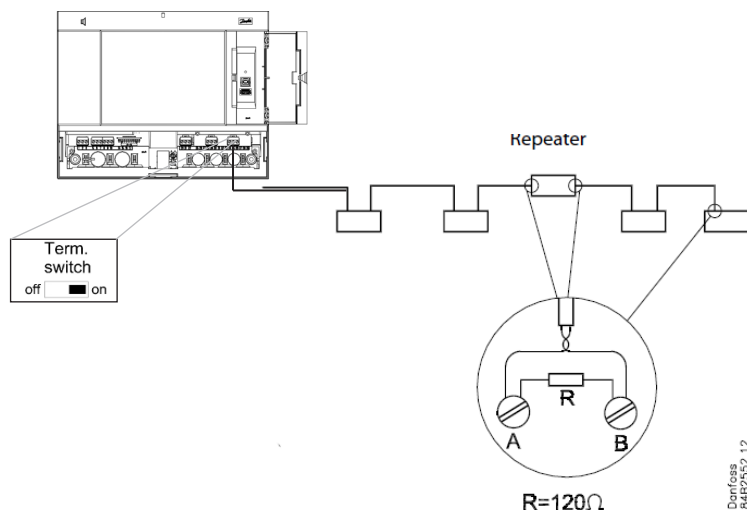

When using the Lon RS485 network, ensure the Term. Switch on the AK-SM is in the 'ON' position (enable internal resistor). Any repeaters must also have 120 Ohm resistor in place. Finally, ensure that the last controller on the network run also has its end of line on line resistor enabled.

Cable type

Cables twisted in pairs must be used, and they may be provided with a screen. Some types of communication require a cable with a screen to be used. The conductor's cross section must be at least 0.60 mm. Examples of cable types:

- Belden 7701NH, single-thread 1 x 2 x 0.65 mm, without screen
- Belden 7702NH, single-thread 2 x 2 x 0.65 mm, without screen
- Belden 7703NH, single-thread 1 x 2 x 0.65 mm, with screen
- Belden 7704NH, single-thread 2 x 2 x 0.65 mm, with screen
- LAPP UNITRONIC Li2YCY (TP), multi-thread 2 x 2 x 0.65 mm, with screen
- Dätwyler Uninet 3002 4P, single-thread 4 x 2 x 0.6 mm, with screen

Cable length

A cable length must not exceed 1200m (4000 foot). A repeater (Part # 084B2241) must be used for longer lengths.

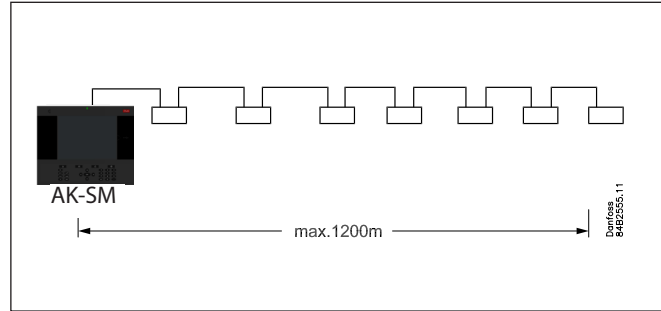

Lon RS485 Topology

The cable connection must be connected from controller to controller, and no branches are allowed on the cable. If the cable length exceeds 1200 m a repeater must be inserted. If the data communication cable runs through an electrically noisy environment which impairs the data signal, one or more repeaters must be added to stabilise the signal.

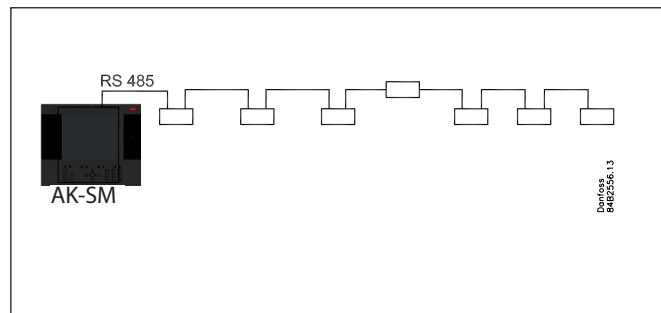

When configuring Lon devices on the control bus, the highest device address that can be used is 127 (max. 120 controller in total)

Conductors

The two wires are looped from device to device. There are no polarisation requirements. (On some controllers, the clamps are designated A and B. On others there is no designation. Otherwise the connections are identical.) If a screen is used, it must be connected to the system device and any repeaters. A screen must always be looped from device to device.

The screen must not be connected to anything else.

(The screen is earthed inside the screen and must not be earthed in any other way.)

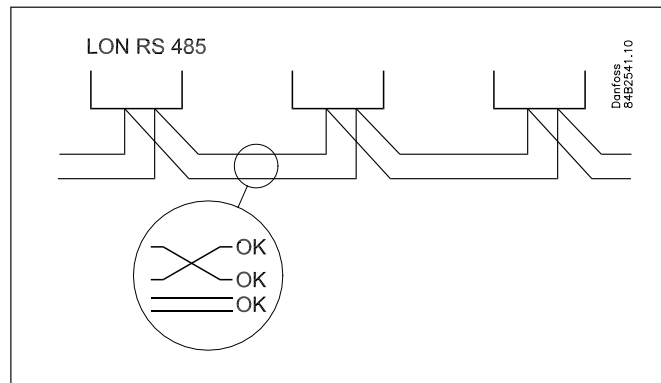

Modbus topology

The cable must be with screen. The cable is connected from controller to controller, and no branches are allowed on the cable. If the cable length exceeds 1200 m a repeater must be inserted. One repeater must be added for every 32 controllers. If the data communication cable runs through an electrically noisy environment which impairs the data signal, one or more repeaters must be added to stabilise the signal.



When configuring Modbus devices on the control bus, the highest device address that can be used is 127 (max. 120 controller in total)

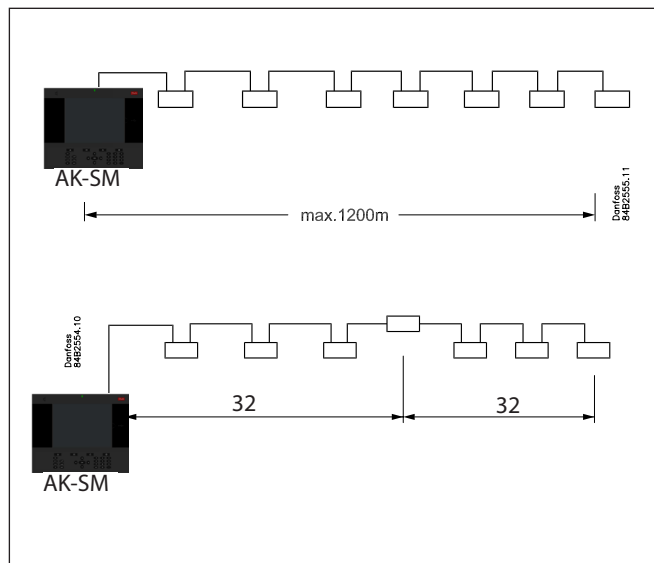

The wires are looped from device to device.

A is connected to A

B is connected to B.

The screen must be connected to the system device, all controller and any repeaters.

A screen must always be looped from device to device.

The screen must not be connected to anything else.

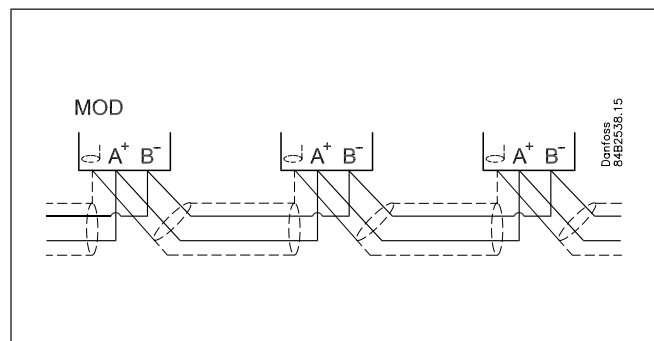

Remote Management Tool (RMT)

The Remote Management Tool (RMT) is a PC software application tool that is designed to support the AK-SM, both in commissioning and service. The RMT is a powerful tool that allows full offline programming and simulation of AK-SM databases, providing the opportunity to save considerable on site commissioning times. In addition, the RMT tool has various remote management features, facilitating complete system management. Creating custom images for the AK-SM web browser is also another function of the RMT tool. The following features can be seen in the RMT;

- **Offline web Programming**
Launch offline web simulator(s) to allow full offline AK-SM database programming, with controller simulation you can fully pre-program your application and save the resulting database to USB for on site install.
- **Program simulation**
From within the web browser session simulate board and point variables to test calculations and system behaviour
- **Custom Graphics**
Use your own Jpeg or bitmap file to create custom images, mapped with any configured system data point
- **FTP (File Transfer Protocol)**
Remotely connect, load and access system files (html web & EDF device files) Retrieve data points
- **Address Book**
Save your most commonly connected site details to allow for one click connection
- **Tools**
Download System software, backup (save) & load database files.
- **Language**
Compatible in multi- languages

The RMT tool is available from your Danfoss sales office with associated supporting documentation.



Required IP ports

As the AK-SM uses IP networking standards to create remote access it may be necessary to configure any site routers to allow incoming connections, either from a LAN or WAN view. The figure below shows a simple IP connection with the AK-SM connected to a standard network router with a typical factory IP address range. From within the LAN any remote connections should 'point' to the master IP address of the AK-SM, in this example `http://192.168.1.100`. If however the remote connection is on a WAN then the LAN router may need to be configured to allow this inbound connection, with the addition of the web port added to the end of the http string.

Please refer to the port allocation table below for remote IP connections

Master IP 192.168.1.100
 Default Gateway 192.168.1.1
 Network Mask 255.255.255.0
 (AK-SM factory set http port = 80)

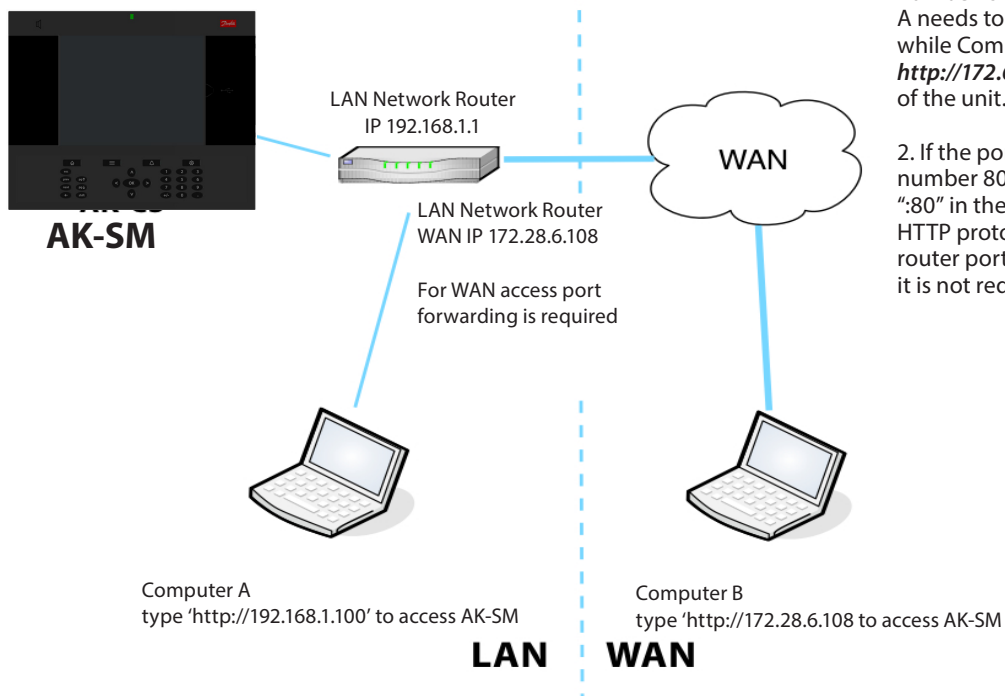

1. The port number is required to be typed into the URL address ONLY if the web port is NOT configured as 80. For example, if the port number is configured as 8080, then Computer A needs to type in `http://192.168.1.100:8080`, while Computer B needs to type in `http://172.68.6.108:8080` to access the website of the unit.
2. If the port number is defined as default number 80, then it is not necessary to type in ":80" in the URL address, this is because the HTTP protocol uses 80 as default port. If the router port forwarding is correctly configured, it is not required in WAN access either.

Port allocation table

| IP Port | Use | Notes |
|--------------|-------------|--|
| - LAN side - | | |
| 80 | web browser | This port is user configurable but factory set to 80 |
| 21 | RMT tool | This port is user configurable but factory set to 21 |
| 25 | e-mail | e-mail output |
| 3001 | XML | Used for XML communications |

Notes for FTP port forwarding in AK-SM units

In AK-SM units, FTP service is a convenient way to download/upload files and updating database/code. **Open FTP server ports to the public internet is not considered as a safe network practice. To avoid these issues, Danfoss strongly suggests FTP functionality in LAN network only . This would reduce the risk of open FTP ports and enhance network security. However, to make the FTP work on WAN side, it must have configured FTP server port opened and forwarded to the public internet.**

Initial Configuration - language

The following section describes the recommended actions to get your AK-SM up and running.

Local keypad - button layout

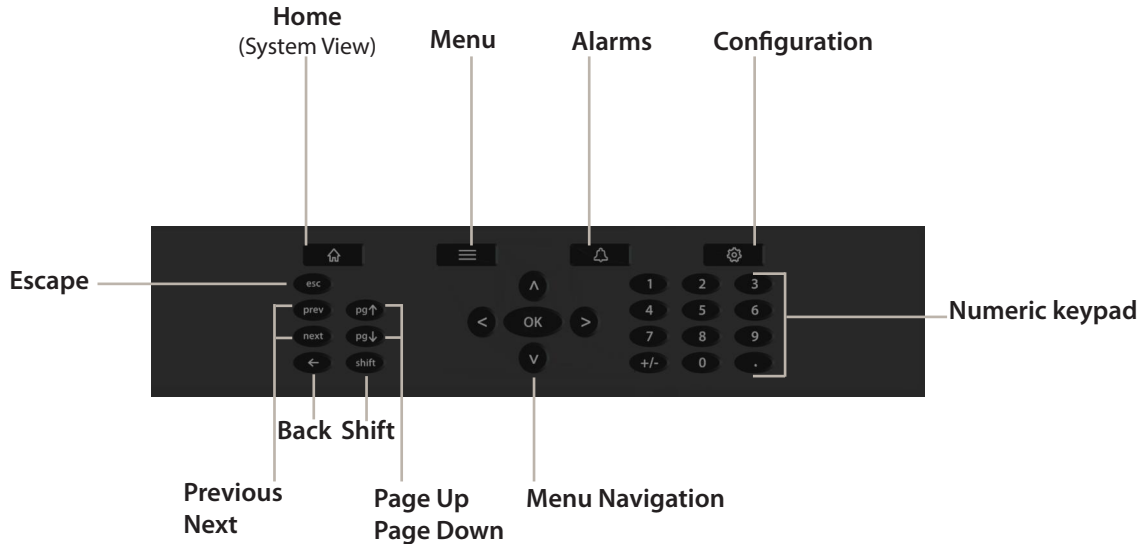

Setting language for local SM display

Your AK-SM can display several different languages. The factory default the unit will display English, in addition your required language can also be enabled. Follow the simple steps below to display your preferred language in the local screen;

1/ Press the Configuration button, and if required enter the factory default user name and password (Supervisor, 12345)

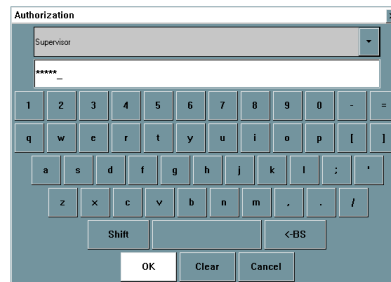

- 2/ Using the arrow keys, navigate to the 'System' memu.
- 3/ Using the down arrow, navigate to the Language line and select your required language
- 4/ Select your language for 'Display'. The unit will then request a re-set.

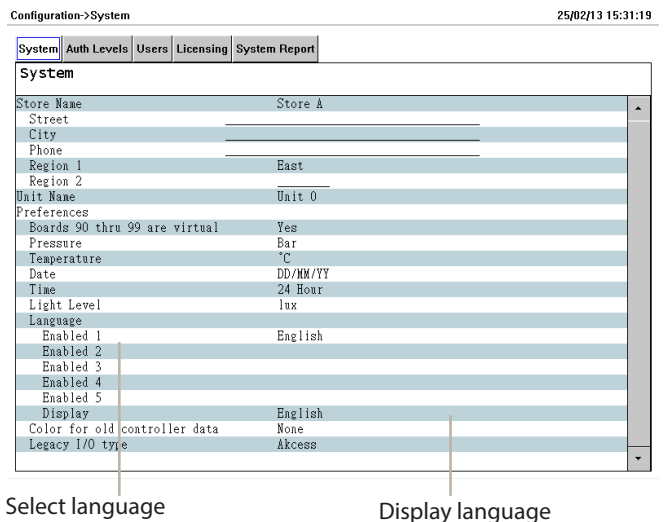

Initial Configuration - Wizard

The following section describes the current Web Wizards, used for simplifying initial settings and Refrigeration layout. The Web Wizards can be used in an offline or online configuration. Danfoss recommends using the AK-SM web environment for commission tasks.

Establish a web connection to your AK-SM (if working online, enter the valid IP address of the AK-SM and apply the factory user name and password). Navigate to the **Configuration** menu

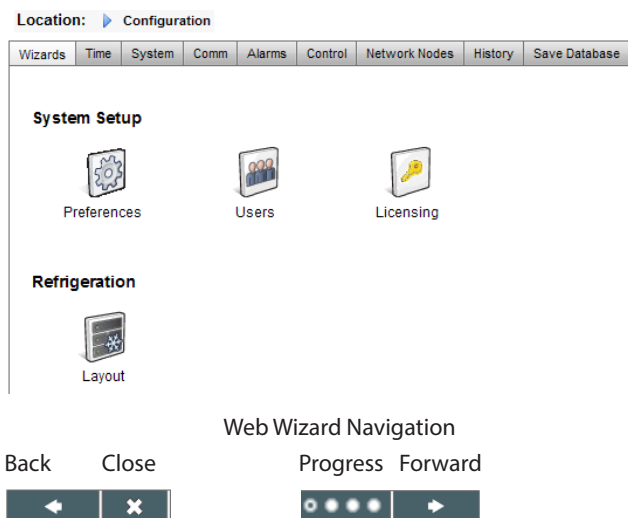

Preferences Wizard (Language, store names, units, preferences, time, date, daylight savings)

- 1/ To easily configure your units preferences, launch the Preferences wizard. Use the Wizard navigation controls to move through the Wizard screens.
- 2/ To make changes, double click on the relevant line and continue until the final screen.
- 3/ Press the finish button to complete and close the wizard (return to main wizard screen)

Users Wizard (Create, modify users, user groups, authorization levels)

- 1/ Enter number of users required (max 22), set password and browser language for each user
- 2/ Enter the number of authorization types (max 7), against the settings line double click to modify the scope of system access
- 3/ Press the Finish button to complete the Web Wizard

Licensing Wizard (Enter new license functionality)
Not currently used

Refrigeration layout Wizard (used to define your refrigeration layout, grouping case with packs, forming associations)
One of the main features of the refrigeration layout wizard allows the user to make use of a network scan. The principle is that the wizard is initially used to initiate a network scan, discover and list what is found. This discovery is then used to easily define the Pack and Case controller relationships (suction groups). The wizard allows for easy drag and drop association, the net result is that once completed the refrigeration layout is built in the AK-SM. The Refrigeration layout Wizard can be used during a live connection to your AK-SM or can be used when programming offline.

limitations: Whilst the wizard will layout the Pack and Case relationships, further controller configuration may be required. Refer to section **6** under 'Configuration' for guidance on any remaining configuration areas required. Currently the wizard is intended for Pack and Case devices, any controls not designated as such will have to be configured using traditional config methods (see Configuration section).

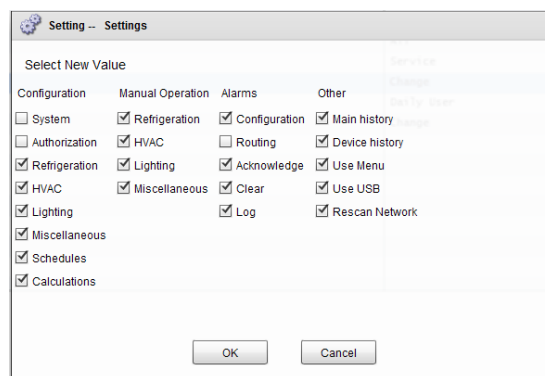

Open the Refrigeration layout wizard and follow the described steps, each step has some description for the available actions. The following wizard screens are available in sequential order;

- Network** (select and perform network scan)
- Discovery** (list scanned devices)
- Compressors** (Input Pack controller name, view address, model, add, copy, remove)
- Circuits** (Input Evaporator controller name, view address, model, add, copy, remove)
- Section Group mapping** (Drag and drop your evap controllers under each pack)
- Summary** (view your groupings before finishing wizard and thus processing your selections to the AK-SM)

After the relevant networks have been selected an scanned the 'Discovery' screen will show all detected devices. Once satisfied with the correct content press the forward button to continue the wizard.

| Status | Name | Address | Model | Type | Code # | Version | Device Bus |
|--------|---------|---------|----------------|------|---------|---------|------------|
| 1 | 51DC-51 | 51 | AK-C250-A-015x | PACK | 0448007 | 01.50 | MODBUS |
| 2 | | 2 | AK-C250-A-015x | Case | 0448020 | 01.50 | MODBUS |
| 3 | | 3 | AK-C250-A-015x | Case | 0448020 | 01.50 | MODBUS |
| 4 | | 4 | AK-C250-A-015x | Case | 0448020 | 01.50 | MODBUS |
| 5 | | 5 | AK-C250-A-015x | Case | 0448020 | 01.50 | MODBUS |
| 6 | | 6 | AK-C250-A-015x | Case | 0448020 | 01.50 | MODBUS |
| 7 | | 7 | AK-C250-B-015B | Case | 0448020 | 01.50 | MODBUS |
| 8 | | 8 | AK-C250-A-015x | Case | 0448020 | 01.50 | MODBUS |
| 9 | | 9 | AK-C250-A-015x | Case | 0448020 | 01.50 | MODBUS |
| 10 | | 10 | AK-C250-A-015x | Case | 0448020 | 01.50 | MODBUS |
| 11 | | 11 | AK-C250-A-015x | Case | 0448020 | 01.50 | MODBUS |
| 12 | | 12 | AK-C250-A-015x | Case | 0448020 | 01.50 | MODBUS |
| 13 | | 13 | AK-C250-A-015x | Case | 0448020 | 01.50 | MODBUS |
| 14 | | 14 | AK-C250-A-015x | Case | 0448020 | 01.50 | MODBUS |
| 15 | | 15 | AK-C250-A-015x | Case | 0448020 | 01.50 | MODBUS |
| 16 | | 16 | AK-C250-A-015x | Case | 0448020 | 01.50 | MODBUS |
| 17 | | 17 | AK-C250-A-015x | Case | 0448020 | 01.50 | MODBUS |
| 18 | | 18 | AK-C250-A-015x | Case | 0448020 | 01.50 | MODBUS |
| 19 | | 19 | AK-C250-A-015x | Case | 0448020 | 01.50 | MODBUS |
| 20 | | 20 | AK-C250-A-015x | Case | 0448020 | 01.50 | MODBUS |
| 21 | | 21 | AK-C250-A-015x | Case | 0448020 | 01.50 | MODBUS |
| 22 | | 22 | AK-C250-A-015x | Case | 0448020 | 01.50 | MODBUS |
| 23 | | 23 | AK-C250-A-015x | Case | 0448020 | 01.50 | MODBUS |
| 24 | | 24 | AK-C250-B-015B | Case | 0448020 | 01.50 | MODBUS |
| 25 | | 25 | AK-C250-B-015B | Case | 0448024 | 01.50 | MODBUS |
| 26 | | 26 | AK-C250-B-015B | Case | 0448024 | 01.50 | MODBUS |
| 27 | | 27 | AK-C250-B-015B | Case | 0448024 | 01.50 | MODBUS |
| 28 | | 28 | AK-C250-B-015B | Case | 0448024 | 01.50 | MODBUS |
| 29 | | 29 | AK-C250-B-015B | Case | 0448024 | 01.50 | MODBUS |
| 30 | | 30 | AK-C250-B-015B | Case | 0448024 | 01.50 | MODBUS |
| 31 | | 31 | AK-C250-B-015B | Case | 0448024 | 01.50 | MODBUS |
| 32 | | 32 | AK-C250-B-015B | Case | 0448024 | 01.50 | MODBUS |
| 33 | | 33 | AK-C250-B-015B | Case | 0448024 | 01.50 | MODBUS |
| 34 | | 34 | AK-C250-B-015B | Case | 0448024 | 01.50 | MODBUS |

The 'Compressors' screen allows for custom text input. If working offline (programming a database not being connected to a AK-SM) the Add, Copy and Remove buttons can be used.

This wizard screen allows you to order and manage compressor controllers discovered on the local bus network and from the offline programming database.

Use the Add button to add a new offline device. Edit model, name, and address by double-clicking in the appropriate field. Note: not all device types allow editing of all fields and the addresses of I/O points are set outside this wizard.

You may also add new offline devices by selecting an existing device and pressing the Copy button.

Use drag and drop to arrange the devices in the desired configuration order.

| Name | Address | Model | #Section Groups |
|---------------|---------|---|-----------------|
| 531D1-51 | 51 | EKC531D1(1)-013x-0848B007 app 0511 s/w 1.30 thru 1.30 | 1 |
| 531D1-59 | 59 | EKC531D1(1)-013x-0848B007 app 0511 s/w 1.30 thru 1.30 | 1 |
| AK-PC781-100 | 100 | AK-PC781-040x (0802186) s/w 4.00 thru 4.00 | 1 |
| Controllers D | --- | No Compressor | 1 |
| Controllers E | --- | No Compressor | 1 |

Double click the 'Name' line to enter a custom description for the device. Pressing return will automatically focus on the next device name in the list.

Use the Add button when creating offline nodes. Double click the 'model' line to bring up a selection of nodes



If your scanned list has known devices that are standalone (not associated with a Pack) these must be mapped under 'No Compressor'. Manually add a new compressor and double click the model line and select 'No Compressor'. When the final wizard screen is presented any standalone controls can be mapped under this 'No Compressor' group.

| Name | Address | Model |
|------------|---------|---------------|
| Standalone | --- | No compressor |

The 'Circuits' screen follows the same principle as the Compressors screen.

| Name | Address | Model |
|----------------|---------|--|
| Add name here. | 1 | AK-CC550-A-015x-0848B020 app 0511 s/w 1.50 thru 1.50 |
| case 1 | 2 | AK-CC550-A-015x-0848B020 app 0511 s/w 1.50 thru 1.50 |
| case 2 | 3 | AK-CC550-A-015x-0848B020 app 0511 s/w 1.50 thru 1.50 |
| case 3 | 4 | AK-CC550-A-015x-0848B020 app 0511 s/w 1.50 thru 1.50 |
| 5 | 5 | AK-CC550-A-015x-0848B020 app 0511 s/w 1.50 thru 1.50 |
| 6 | 6 | AK-CC550-A-015x-0848B020 app 0511 s/w 1.50 thru 1.50 |
| 7 | 7 | AK-CC550-B-015B-0848B020 app 0511 s/w 1.50 thru 1.50 |
| 8 | 8 | AK-CC550-A-015x-0848B020 app 0511 s/w 1.50 thru 1.50 |
| 9 | 9 | AK-CC550-A-015x-0848B020 app 0511 s/w 1.50 thru 1.50 |
| 10 | 10 | AK-CC550-A-015x-0848B020 app 0511 s/w 1.50 thru 1.50 |
| 11 | 11 | AK-CC550-A-015x-0848B020 app 0511 s/w 1.50 thru 1.50 |
| 12 | 12 | AK-CC550-A-015x-0848B020 app 0511 s/w 1.50 thru 1.50 |
| 13 | 13 | AK-CC550-A-015x-0848B020 app 0511 s/w 1.50 thru 1.50 |
| 14 | 14 | AK-CC550-A-015x-0848B020 app 0511 s/w 1.50 thru 1.50 |
| 15 | 15 | AK-CC550-A-015x-0848B020 app 0511 s/w 1.50 thru 1.50 |

The 'Suction group mapping' screen allows for the defined evaporator devices to be 'mapped' under the required Pack controller. This mapping forms a relationship or grouping between the pack and the evaporator devices. This grouping association will then be seen in the AK-SM configuration and dashboard screens (and can be used to easily set up master control functions like Suction optimization).

As the user description indicates, use a drag and drop action to group your controls. Use the CTRL key and multi-select cases to save time when making bulk actions. You can remove any case devices by simply dragging back to the available case list.

The check box labelled 'Allow multi-case circuit creation' is to support Centralized refrigeration control configuration, where multiple case circuits are available'. Leave this check box empty if you are using a de-centralized control strategy (i.e. Case and pack controllers)

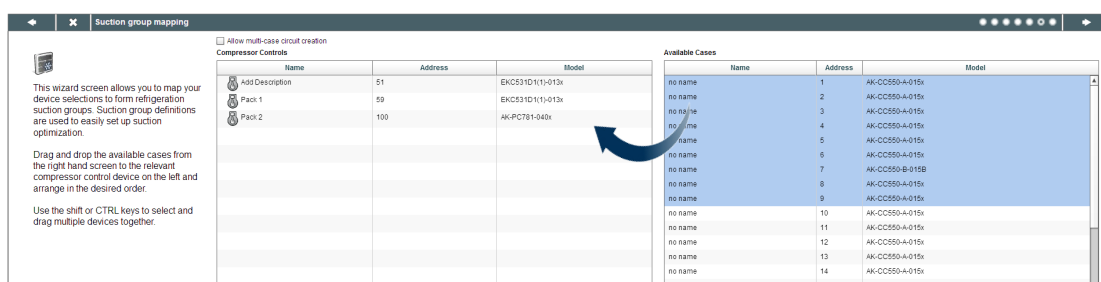

Once satisfied with the mapping, press the forward button and the summary screen will be shown. Pressing the finish button will then send your configuration layout to the AK-SM. During this time a progress bar will be shown and finally a status dialogue box.

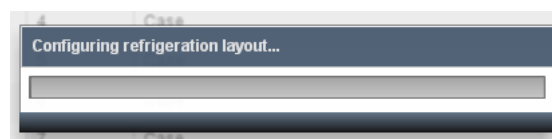

This completed wizard process will layout your refrigeration application. Typically some additional configuration tasks will then need to be completed (i.e. define alarms, setpoint changes, configure history), please refer to the following section for further details on detailed configuration.

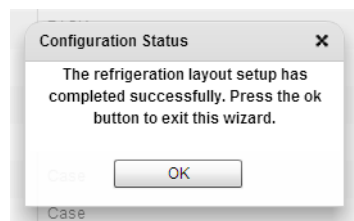

Configuration

The following section describes the typical steps required for commissioning and configuration of your AK-SM. Although site applications can differ from one site to another, many setup procedures are common. This setup section assumes the AK-SM is mounted and all necessary power, network cabling and controllers are in place. The described work flow is based around the AK-SM web browser interface, but would equally apply if being done via the local screen. Further detailed commissioning instructions are found throughout this user guide.

The AK-SM offers unique control flexibility in that both centralized and de-centralized control methods are supported. The term 'centralized' is used to describe the control of refrigeration Racks via I/O (Danfoss Input / Output modules). Under this method of control the refrigeration control is managed directly from the front end (AK-SM), with field bus I/O. De-centralized control is the term used to describe the full support of Danfoss Pack and Case controllers. Under this method, each Pack or Case controller on the network can be seen as self contained, with control logic built in. The front end (AK-SM) under this type of application is more of a network manager, providing full read / write access and energy saving functions.

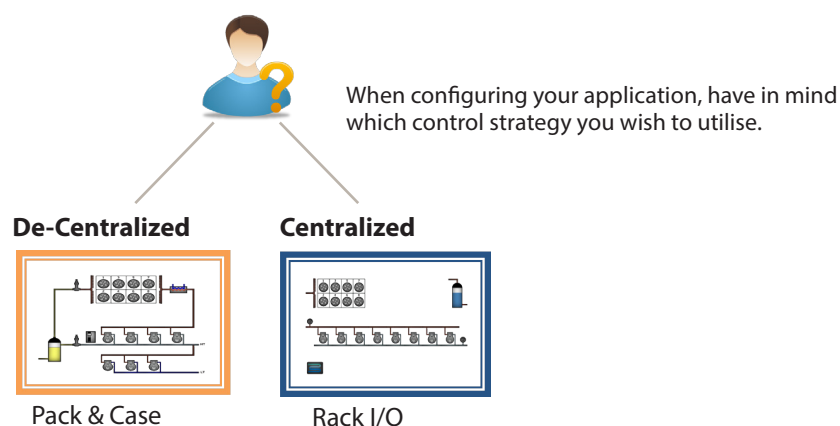

When starting your system configuration you will have the opportunity to select either Centralized or De-centralized (or a mix of both) control methods.

The following areas of system configuration will be covered in this section;

- 1 **Network Nodes** (Network scan/ Node overview, Points, scan /config status, duplicates, upload/download)
- 2 **Time** (Set time/date, time zone, operating Hours, Daylight savings, Holidays)
- 3 **System** (Store / Region Names, Units preferences, Authorization levels and users)
- 4 **Communication** (DNS, DHCP, IP Ports)
- 5 **Alarms** (XML, e-mail, Routing)
- 6 **Control** (Configure Refrigeration, Lighting, Miscellaneous, Energy meters and Gas detection)

Once successfully logged into the AK-SM (web) and assuming you have the required authorization, system configuration is done via the central '**Configuration tab**'. Clicking this tab reveals the configuration 'sub tabs'. Depending on your selection, these sub tabs will change dependent on content.

Using the menu structure seen in the 'Configuration' page, a step by step process can be applied when setting up your AK-SM.

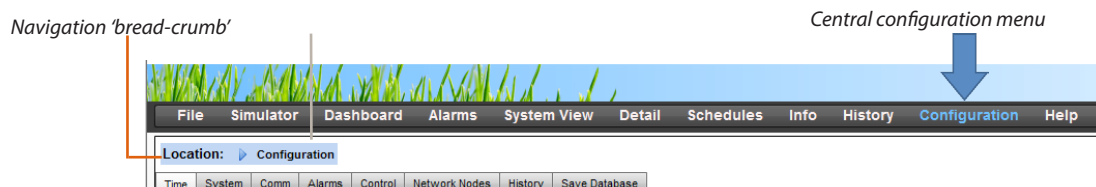

1 Network Nodes

If your application already has controllers and/or I/O modules set and powered you may wish to perform a network scan to validate their connection to the AK-SM. Follow this section to perform a network scan

From the Configuration tab select the 'Network Nodes' sub-tab. When your field network is complete and all controllers are on line a network scan can be initiated. The operation of a network scan allows the AK-SM to be aware of any controller devices on the network, allowing the AK-SM to communicate and function with the controllers on the field bus.

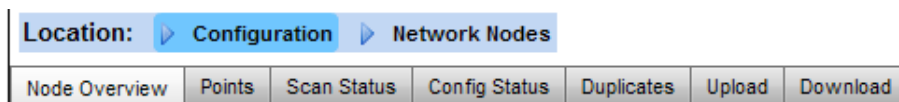

Use this screens to perform network scan

Relays | Sensors | On/Off | Variable Output

This tab relates to any AK I/O configured points, the term *points* relates to AK I/O relay, sensors, On/Off Inputs and variable outputs. Any control questions that have required AK I/O control will be seen in these tabs. The purpose of these tabs is to allow the viewing of the I/O point status.

All nodes | Controllers | I/O boards | Other nodes

The scan status menu/tabs allows the user to view any scanned nodes found on the network.

All Nodes: Central list will display configured devices and points. Only configured controllers will be visible in this list.

Controllers: view any scanned generic controllers. This screen will also reflect address and controller type

I/O Boards: Display AK Board & Point status.

Other Nodes: List of other nodes

Ensure the appropriate network channel is selected, and press the 'complete rescan' line. The AK-SM will now scan the network to identify any connected and addressed controller nodes. The text on the screen will reflect the scan progress, after a scan the time & date will be shown (indicating last scan)

For SLV support, select Modbus channel

Duplicates Tab

Check this list to make sure no two devices have been assigned the same network address. Any duplicate address will be shown in this list. Correct any address issues and re-scan.

Upload Tab

The upload tab will list any controllers that have been uploaded. The upload function can be performed in the Configuration->Control area (one controller at a time) or here (multiple devices with one command). The process of an upload takes the current parameter settings and values from the controller(s) and loads them into the AK-SM database. This operation ensures that the AK-SM database is synchronised with any pre-configured controllers on the control network. Any upload failure will be shown on this screen, else a time / date stamp will be shown when successful

Download Tab

The download tab will list any controllers that have been processed for download (where the AK-SM sends parameter data to the device). The download function can be performed individually under the Configuration->Control page or here, where multiple controllers can be selected for download (using one command). The process of a download takes the AK-SM database values and downloads them to the selected controller(s). Any upload failure will be shown on this screen, else a time / date stamp will be shown

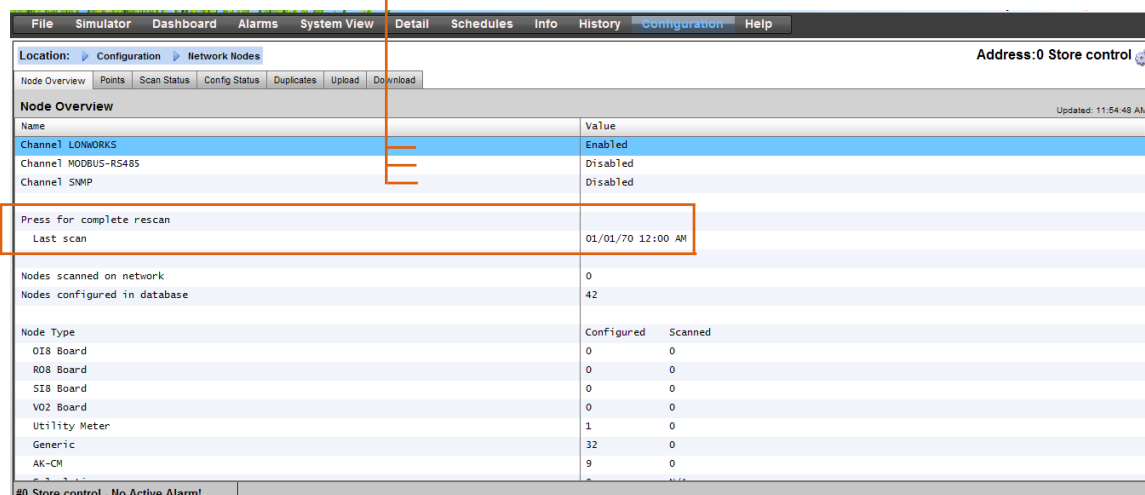

After the network scan has completed, any resulting count will be seen against the **Nodes Scanned on Network** line - this reflects the number of found nodes on the scan just completed. The corresponding line below (**Nodes configured in database**) reflects the current total of network nodes actually configured in the AK-SM database.

The last group in this table refers to the following node types;

- OI (Output|Input)
- RO (Relay output)
- SI (Sensor Input)
- VO2 (Variable output)
- Utility Meter (WattNode, Veris, Carlo Garvazzi)
- Generic (Danfoss case / pack controllers)
- AK-CM (AK- Communication Modules)
- Calculations

| Press for complete rescan | | |
|------------------------------|-------------------|---------|
| Last scan | 01/01/70 12:00 AM | |
| Nodes scanned on network | 0 | |
| Nodes configured in database | 42 | |
| Node Type | Configured | Scanned |
| OI8 Board | 0 | 0 |
| RO8 Board | 0 | 0 |
| SI8 Board | 0 | 0 |
| VO2 Board | 0 | 0 |
| Utility Meter | 1 | 0 |
| Generic | 32 | 0 |
| AK-CM | 9 | 0 |
| Calculations | 0 | N/A |

Each node (type) has a column that reflects any configured or scanned status.

2 System configuration (Time settings / preferences)

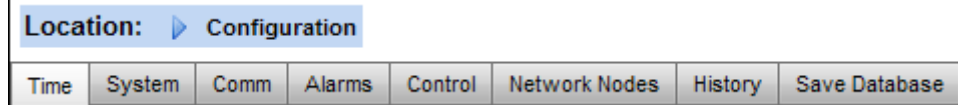

The Time tab allows the *system time, time zone, operating hours, daylight savings and holidays* to be configured. Double click a line to make any changes.

The following examples can be seen for the time zone;

- London (GMT) = 000
- Central Europe = 100
- East Coast USA = -500

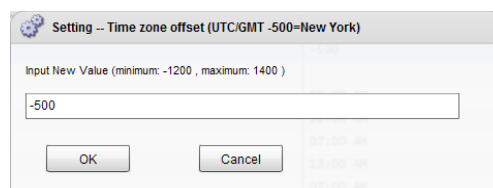

The operating hours can be set that reflect your store operating hours. Any times set in this section can then be referenced to via a 'Relative schedule'. Relative schedules are found under the 'Lighting' and 'HVAC' application areas and apply a (user selectable) offset which references the operating hours schedule.

3 System configuration (Time settings / preferences)

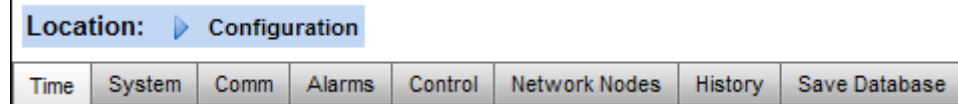

After completing the required settings in the 'time' tab, navigate to the 'system' tab. Under the system tab add the store name and region / preference setting and information.

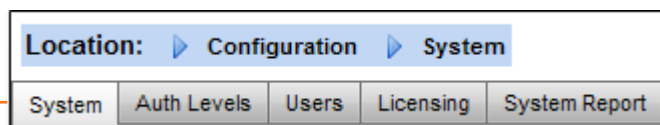

Use this screen to configure 'Store name/details, unit name, preferences, system language'. Double click the appropriate line to make changes

'Color for old controller data' is an option to reflect data that has yet been updated via a network poll. Data with a * indicates either an offline condition or that the AK-SM is waiting for a fresh update from the device

Legacy I/O type is used to set legacy supported devices

Reflects what license is configured for your AK-SM. Different license allow additional functionality

The Users screen allows the definition of up to 20 users

The Auth (Authorization) screen allows the definition of up to 7 authorization types.

The system report screen allows the user to define what content should be included. Alarms, Schedules, scanned devices, Audit trail and controller database are available options. To generate a system report go the main web menu and select File/Download Report

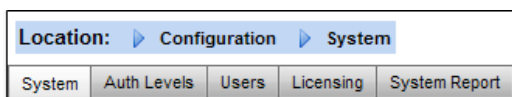
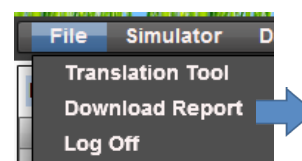

The Auth (Authorization) Levels tab allows the definition of up to 7 authorization types. Custom authorization types can be configured with certain system privileges / access. In the example below, 4 auth levels have been defined (factory setting is 3). Level 1 (Supervisor) cannot have the settings changed. To change the level of access of other auth levels, navigate to the desired line and select from the Authorization pop up dialog box. As factory standard, 3 levels are predefined (Supervisor, Service, Daily User), the service and daily user levels can be changed as required.

| Auth Levels | |
|-------------------------------|----------------|
| Name | Value |
| Number of authorization types | 4 |
| Level 1 | Supervisor |
| Settings | All |
| Level 2 | Service |
| Settings | Change |
| Level 3 | Daily User |
| Settings | Change |
| Level 4 | Danfoss Custom |
| Settings | Change |

To add/delete auth levels select the 'Number of authorization types' line (max 7 levels)

The Supervisor name can be changed but the level of access / privileges are factory set.

Adding new auth levels allows new users to have specific access to key system areas. Once new auth types have been created, enter custom name and define level of access by selecting the Settings line (Authorization pop up box will appear)

The following areas of authorization are available;

Configuration

System: Access to the System tab

Authorization: Access to the Authorization tab

Refrigeration: Access to Refrigeration configuration

HVAC: Access to HVAC configuration

Lighting: Access to Lighting configuration

Miscellaneous: Access to Misc configuration

Schedules: Access to Schedule configuration

Calculations: Access to Calculations configuration

Manual Operation (seen under Service tab in device detail page)

Refrigeration: Allow user to perform the following operations on Danfoss case controllers ;
Main Switch, Defrost, Cleaning, Lights, Night Setback, Shutdown

HVAC: Allow user to perform the following operations to Relay, Inputs & sensor overrides

Lighting: Allow user to perform the following operations
-override relay

Miscellaneous: Allow user to perform the following operations
-override relay, sensor inputs

Alarms
Configuration: Allow user to configure alarms

Routing: Access to the alarm routing

Acknowledge: Allow user to acknowledge

Clear: Allow user to clear alarms

Log: Allow user to set alarm level to log

Other

Main Menu: Allow user to access main menu

Device History: Allow user to access device history

Use Menu: Allow access to Menu function

Use USB: Allow use of USB flash

Rescan Network: Allow user to rescan network

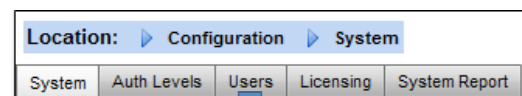
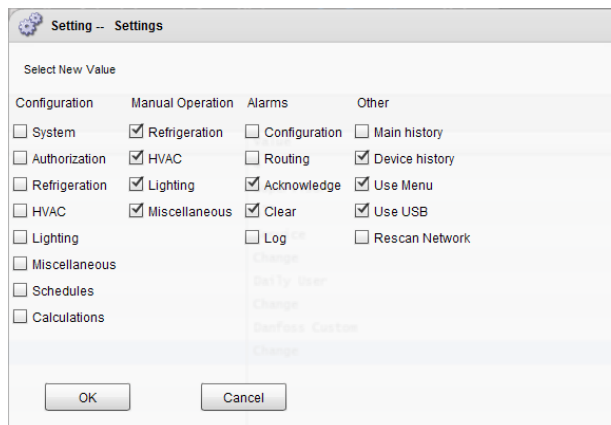

Users tab

The next tab (user tab) allows the definition of up to 20 users. A custom name and password can be given for each user. The appropriate level (defined in Auth Level tab) can be assigned to each user. The AK-SM always maintains a single user in the system profile and this level is factory set to the Supervisor level. To add users simply enter the required value in the 'number of users' line. The Browser language line reflects what language will be displayed in the web browser upon this user logging on [via browser access].

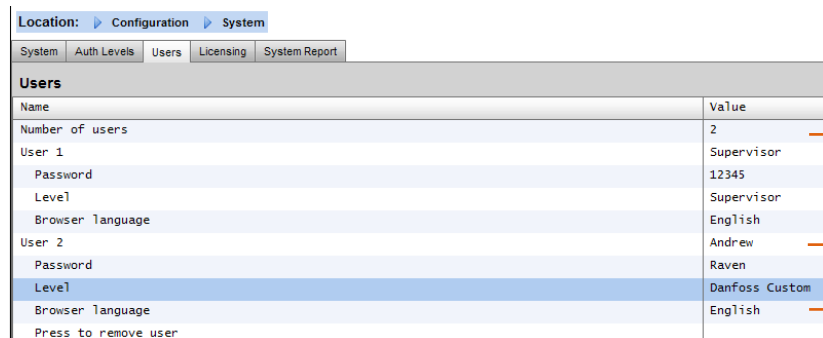

To add users select the 'Number of users' and enter required number

Enter custom name, password and auth level for user.

Browser Language: This defines the language that will be displayed when the user log on via the web browser access.

4

Communication

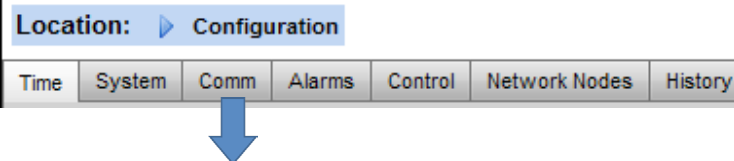

The Comm (Communications) screen allows for IP network settings to be configured. Follow the question lines on the screen to configure your AK-SM according to site requirements. Any changes in IP configuration will require an AK-SM system reset.

| Comm | |
|--|-------|
| Name | Value |
| Name | |
| Press to reset this unit | |
| Internet | Yes |
| NOTE: Reset unit after making changes! | |
| Use DNS | Yes |
| Use DHCP | Yes |
| Use IP address as backup | |
| if DHCP fails | No |
| Master IP Address | |
| Preferred Hostname | Yes |
| Master Node Name | |
| No of Ext. Internet | 0 |
| Web Server Port | 80 |
| FTP Server Port | 21 |
| FTP Data Port | 20 |
| Network timing support | No |

- Select 'Yes' if a DNS service is to be used. Preferred host name can be entered if setup in router config
- Select 'Yes' if AK-SM is to be connected to a DHCP server
- Select yes and manually enter the IP address that the AK-SM will use if DHCP fails.
- Master IP address - if using multiple AK-SM controllers in a host network, enter the Master (unit address 0) IP address
- Internet IP address - Specify public IP address which is used to contact your AK-SM via an Internet based connection. Factory web (HTTP) port is 80 & FTP port is 20 and 21, both can be changed to suit your network application.
- If your network supports NTP, select 'yes' to the question 'Network timing support?'

5

Alarms

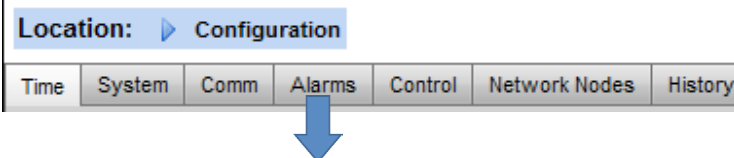

The Alarms screen has a sub set of screen [Connections, Service, Alarm Routing, Relays, System, I/O Comm]. Go through each sub tab to ensure all areas are correctly configured as per site requirements.

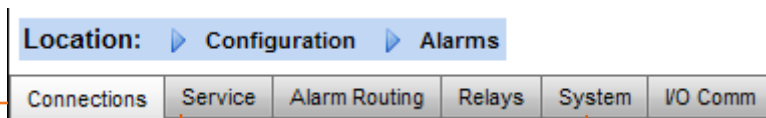

Define the number of connections (typically network should be selected), then select the connection type [e-mail, Remote (Danfoss Retail Care), XML]

The service tab is designed to allow test alarms to be generated. There is also an auto alarm test that can either be on a scheduled or repeated basis.

The AK-SM utilizes an Alarm Action Matrix that allows a high degree of flexibility for various alarm routing options. At the heart of the alarm configuration is the 'Alarm Routing' page, where different routing options can be defined, along with time delays and alarm output stop conditions.

AK-SM system based alarm conditions should be set under the **System** tab. If the alarm output includes relay(s) the **Relays** tab should be accessed to configure the board & point address for these relays

If Controllers (Danfoss Evap & Pack, Power meters) and I/O has been used in the control configuration (Lighting, HVAC, Refrigeration etc.), these devices can be seen under the I/O Comm tab.

Connections screen - Define the number of connections, then select the connection type. Your AK-SM can offer the following alarm IP based alarm output; e-mail, Remote (Danfoss Electronic delivered services) and XML. Depending on your configuration the screen will reflect the required inputs in order to satisfy the output. In order for any alarms to be routed out of your AK-SM please ensure a schedule is configured. Failure to set a schedule will inhibit any alarm output.

Location: Configuration Alarms

| Connections | |
|-------------------------------|----------|
| Name | Value |
| Number of network connections | 1 |
| Network Connection 1 | |
| Type | XML |
| Name | |
| Address | |
| Date | MM/DD/YY |
| Lang | English |
| Time | 24 Hour |
| Port | 3001 |
| Delay | 5 min |
| Schedule 1 | Standard |
| From | 00:00 |
| To | 00:00 |
| Days | SMTWRFA |
| Holidays | 12345678 |
| Schedule 2 | Not Used |

To configure a network connection select 'Number of network connections'

Type (e-mail | Remote | XML)



Ensure a schedule is defined to allow alarm output

Example of e-mail configuration

Location: Configuration Alarms

| Connections | |
|--------------------------------|------------------------|
| Name | Value |
| Number of network connections | 1 |
| Network Connection 1 | |
| Type | E-Mail |
| E-Mail Configuration | |
| Server | |
| Type | Name |
| Name | smtp.danfoss.net |
| Use authentication | Yes |
| User name | your value here.. |
| Password | your password |
| Send To | |
| 1 | andrew@mytest.com |
| 2 | dave@mytest.com |
| 3 | |
| Reply To | anyaddress(mytest.com) |
| Send abbreviated alarm message | No |
| Date | MM/DD/YY |
| Lang | English |
| Time | 24 Hour |
| Port | 25 |
| Schedule 1 | Standard |
| From | 00:00 |
| To | 00:00 |
| Days | SMTWRFA |
| Holidays | 12345678 |
| Schedule 2 | Not Used |

Enter valid server name (or IP) for e-mail server
If your e-mail service requires user authorization, enter user name and password

Send to: Add the e-mail address for intended recipients

Reply to: A mandatory field that must have a valid entry (address with same domain name). An abbreviated message would have reduced text in the alarm message

Configure a schedule to enable the alarm e-mail output

3G Wireless routers

3G technology offers many benefits over standard dial up connections. Utilizing a 3G connection the full range of AK-SM services can be used, including web browser, and RMT. Where Internet / Intranet connection is not available, Danfoss recommends considering 3G as a means of offering IP connectivity. Please consult your local Danfoss sales office with regard to 3G connectivity.

Service tab

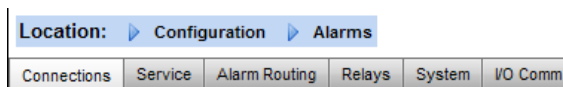

Use the service screen to send test alarms. You may configure the alarm type and alarm action logic (1-8). In addition, scheduled or repeat test alarms can be configured on this screen. The internal alarm relay can also be tested from this screen.

Disabled = No alarms will activate on this point

Log Only = When an alarm occurs on this alarm point it will only register in the AK-SM alarm log - no physical alarm output

Normal = When alarm is active the output will be sent once (alarm may get re-triggered if the stop condition is set for repeat)

Severe = When alarm is active the output will get re-sent every xx min

Critical = Same as Severe but with separate re-trigger time - when alarm is active the output will get re-sent every xx min

Delete = Removes any applied alarm settings

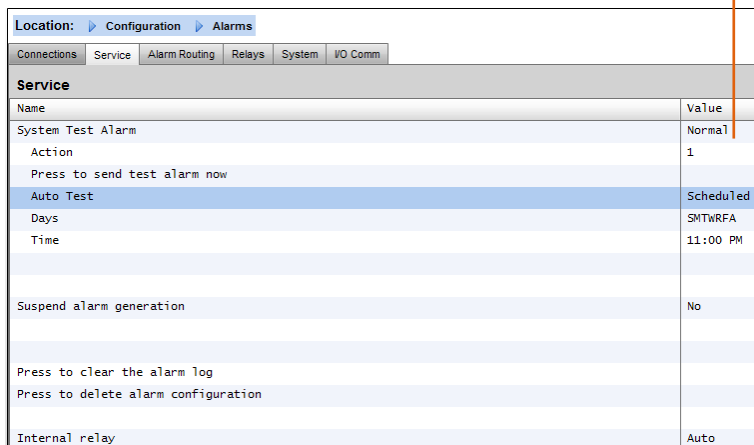

Select Alarm Action type (defined under Alarm routing)

Auto Test:

Scheduled: Configure days & time for test alarm
Repeated: Configure interval time for test alarm

Suspend alarms generation (suspend All alarms in the system from being sent): Set time period (min/Hrs) to stop alarms being sent

Any relays configured for alarm output can be forced on / off for testing purposes.



Remember to leave in Auto position after testing

Routing tab

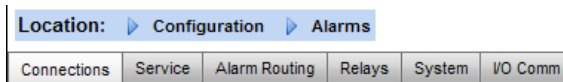

The AK-SM utilizes an Alarm Action Matrix that allows a high degree of flexibility for various alarm routing options. At the heart of the alarm configuration is the '**Alarm Routing**' page, where different routing options can be defined, along with time delays and alarm output stop conditions.

The central alarm action matrix allows various output options (known as alarm **actions**) and alarm handling configuration to be centrally assigned. Once the alarm action matrix has been defined, any controller or I/O point can be given an alarm **action** number. The alarm **action** number corresponds to the appropriate output. (as defined in the alarm routing page). Alarm output options include;

- 5 external (AK I/O) relay outputs
- Local AK-SM buzzer
- Local AK-SM front LED
- Internal alarm relay
- 2 Network connections
- 6 IP / e-mail addresses
- Serial printer output.

The following example can be seen as a guide to configuring your AK-SM alarm logic options;

To configure an alarm action, navigate to the required output line (I.E. Relay A) and press enter. The resulting screen allows the configuration of the alarm actions, any pre delays, duration times and stop conditions. The results of this configuration will be shown in the alarm routing page.

Alarm Actions (1-8)

Up to 8 alarm actions can be defined. Each alarm action can have multiple outputs, making the AK-SM alarm output options very flexible. 'Look down' each alarm action number column and any associated outputs will be seen in the left hand column

Component Column (alarm output)

Select from the options seen in this column;

- Relay A-E
- Front LED
- Buzzer
- Int. Relay
- Network 1
- Network 2

| | 1 | 2 | 3 | 4 | 5 | 6 | 7 | 8 | Del | Dur | Stop |
|------------|---|---|---|---|---|---|---|---|-----|-----|------|
| Relay A | - | - | - | - | - | - | - | - | | | |
| Relay B | - | - | - | - | - | - | - | - | | | |
| Relay C | - | - | - | - | - | - | - | - | | | |
| Relay D | - | - | - | - | - | - | - | - | | | |
| Relay E | - | - | - | - | - | - | - | - | | | |
| Front LED | - | - | - | - | - | - | - | - | | | |
| Buzzer | - | - | - | - | - | - | - | - | | | |
| Int. Relay | - | - | - | - | - | - | - | - | | | |
| Phone 1 | - | - | - | - | - | - | - | - | | | |
| | - | - | - | - | - | - | - | - | | | |

Delay

Once an alarm action is defined the associated time delay for the action can be set. This delay is in addition to any delay already defined in any controller (i.e. EKC) or monitoring points (i.e. I/O) defined in the system.

Duration

A duration time is available when either Time or Time/Repeat are selected as stop conditions. The duration setting defines the length of time the alarm output will be active for (irrespective if the alarm is still active or acknowledged or not) Available in second or minute selections. 0 Sec/Min duration will result in the alarm output remaining off.
 Min = 0 Sec/Min
 Max = 99 Sec/Min

Stop

The stop condition defines when the alarm output will stop or return to configured position. The following definitions apply;

- Time** = Stop on time (set under duration)
- Ack** = Stop on alarm being acknowledged
- Clear** = Stop when alarm clears
- Time/Rep** = Stop after time delay but repeat if alarm is still active
- Ack/Rep** = Stop after alarm is acknowledged. If alarm still active after acknowledge repeat alarm action (repeat)

Alarm Actions (1-8)

Each alarm action can have multiple relays, IP address, etc assigned

Custom text that better reflects the alarm relays can be entered.

Use the 'component name display' to toggle between custom text & factory name (Relay A, Relay B...)

Alarm output options

Select the appropriate 'component' (i.e relay, network) and configure by double clicking on the appropriate line

Location: Configuration > Alarms

| Alarm Routing | | | |
|-----------------------------|--------------------------|--|--|
| Name | Value | | |
| Component name display | Items | | |
| Component | Action Del Dur Stop | | |
| Relay A | X----- 10s --- Clear | | |
| Relay B | -D----- 0m --- Ack | | |
| Relay C | --N----- 0m 10m Time/Rep | | |
| Relay D | ----- --- --- --- | | |
| Relay E | ----- --- --- --- | | |
| Front LED | XXXXXXXXX 0m --- Clear | | |
| Buzzer | ----- --- --- --- | | |
| Int. relay | ----- --- --- --- | | |
| Network 1 | X----- 1m --- Clear | | |
| Network 2 | ----- --- --- --- | | |
| Repeat delay after stop | 5 min | | |
| Send critical alarms, every | 60 min | | |
| Send severe alarms, every | 1440 min | | |

Delays & Stop conditions

Set pre delay, duration and stop conditions (for each alarm output selection)

Example configuration

This example will describe the steps to configure an alarm actions. Alarm action **1** will be defined according to the following;

- **Relay A** should trigger after a 10 second pre delay. This relay will energize any time and will only reset when the alarm clears.
- **The Front LED** should activate (de-activate LED when alarm clears)
- **The Buzzer** should only activate during the Day (Buzzer stops when alarm is Acknowledged)
- Alarm message should also be sent out via **e-mail**

The above alarm outputs are associated with action 1 - 'look down' the alarm action 1 column and the relevant outputs can be seen in the left of the page.

To define the alarm output options navigate down the page and double click the relevant line.

This opens another page that allows the configuration for that output to be set. In the example below **Relay A** and the **Buzzer** can be seen. Follow the same process for the other outputs. For e-mail output, navigate to the Network 1 line and press enter. Here, set the action, time delay & stop conditions. (The actual e-mail configuration is done in the Alarm 'Connections' page).

'Look down' Alarm action 1 column

The results of the alarm output configuration can be seen in the central Alarm Routing page. Follow this process for other actions.

Relay A Configuration page

| Alarm Routing | |
|----------------|--------------|
| Relay A | |
| Name | Relay A |
| Usage | Relay A |
| Action 1 | Enabled |
| Action 2 | Not selected |
| Action 3 | Not selected |
| Action 4 | Not selected |
| Action 5 | Not selected |
| Action 6 | Not selected |
| Action 7 | Not selected |
| Action 8 | Not selected |
| Delay | 10 |
| Units | seconds |
| Stop | Clear |

| Alarm Routing | | | | |
|-----------------------------|----------|--------|-----|----------|
| Name | Value | | | |
| Component name display | Items | | | |
| Component | 12345678 | Action | Del | Dur |
| Relay A | X----- | 10s | --- | Clear |
| Relay B | ----- | | | |
| Relay C | --N---- | 1m | 10m | Time/Rep |
| Relay D | ----- | | | |
| Relay E | ----- | | | |
| Front LED | XXXXXXXX | 0m | --- | Clear |
| Buzzer | D----- | 0m | --- | Ack |
| Int. relay | ----- | | | |
| Network 1 | X----- | 1m | --- | Clear |
| Network 2 | ----- | | | |
| Repeat delay after stop | 5 min | | | |
| Send critical alarms, every | 60 min | | | |
| Send severe alarms, every | 1440 min | | | |

| Alarm Routing | |
|---------------|--------------|
| Buzzer | |
| Name | Buzzer |
| Usage | Buzzer |
| Action 1 | Day |
| Action 2 | Not selected |
| Action 3 | Not selected |
| Action 4 | Not selected |
| Action 5 | Not selected |
| Action 6 | Not selected |
| Action 7 | Not selected |
| Action 8 | Not selected |
| Delay | 0 |
| Units | minutes |
| Stop | Ack |

Action settings:

Once in the actual output page, navigate through the lines and set the relevant Action. Each action can have the following settings;

Not Selected: No action

Enabled: Will enable this output action (any time of day)

Day: Enable this output during day status (based on store opening times (Configuration->Time)

Night: Enable this output during night status (based on time

Outside of store opening times (Configuration->Time)

To complete the output configuration set the time delay, units & stop conditions should be set. Stop conditions;

Time = Stop on time (set under duration)

Ack = Stop on alarm being acknowledged

Clear = Stop when alarm clears

Time/Rep = Stop after time delay but repeat if alarm is still active

Ack/Rep = Stop after alarm is acknowledged. If alarm still active active after acknowledge repeat

Relay tab

Location: Configuration Alarms

| | | | | | |
|-------------|---------|---------------|--------|--------|----------|
| Connections | Service | Alarm Routing | Relays | System | I/O Comm |
|-------------|---------|---------------|--------|--------|----------|



If the alarm output includes relay(s) the **Relays** tab should be accessed to configure the board & point address for these relays. The example below shows relay A & C, with the associated (AK I/O) board & point address.

| Relays | |
|---------|---------|
| Name | Value |
| Relay A | Relay A |
| Address | 01-1.1 |
| Type | N-Open |
| Relay C | Relay C |
| Address | 01-1.2 |
| Type | N-Open |

Enter the AK I/O board & point location for the relay(s)

Select N-Open / N-Closed as required

System tab

Location: Configuration Alarms

| | | | | | |
|-------------|---------|---------------|--------|--------|----------|
| Connections | Service | Alarm Routing | Relays | System | I/O Comm |
|-------------|---------|---------------|--------|--------|----------|



AK-SM system based alarm conditions should be set under the **System** tab. The alarms seen in this page are factory set but can be changed as per site requirements. Navigate down each line and configure (pressing the enter key) as required. The following items can be seen and changed under the System tab;

I/O Network Fail: Alarm if communications to AK I/O fails

Flash Memory fail: Alarm if AK-SM system memory fails

Database Cleared: Alarm if AK-SM database is cleared

File Error: Alarm if critical files do not load / not present on AK-SM system (I.E. Device list missing)

Alarm send fail: Alarm if any active alarms were unable to be sent out

NTP Failure: Alarm if the network time protocol fails

Host Comm: Alarm If host communication fails

Host Count: Alarm if one or more AK-SM units disconnect from host network

Ram Disk Full: Alert alarm if Ram is getting full (due to EDF files)

| System | |
|-------------------|----------|
| Name | Value |
| Host Comm error | Normal |
| Action | 1 |
| Host count error | Normal |
| Action | 1 |
| I/O Network fail | Normal |
| Action | 1 |
| Flash memory fail | Normal |
| Action | 1 |
| Database Cleared | Normal |
| Action | 1 |
| File Error | Normal |
| Action | 1 |
| Alarm send failed | Log Only |
| Low battery | Critical |
| Action | 1 |
| NTP Failure | Log Only |
| RAM disk full | Normal |
| Action | 1 |

Factory settings can be changed as per customer requirements.

Alarm level & Actions can be changed

I/O Comm tab

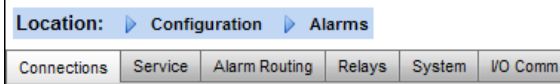

If Controllers (Danfoss Evap & Pack, Power meters) and, I/O has been used in the control configuration (Lighting, HVAC, Refrigeration etc.), these devices can be seen under the I/O Comm tab.

The I/O Comm tab allows any offline communication alarms to be configured. The example below shows an evaporator controller (address 1) with the alarm level set to 'Normal' & alarm action '1'. These factory settings can be changed in this page.

Any AK I/O points used in the AK-SM system can be found on this page, with the associated alarm level and actions set. The factory settings can be changed as required.

| Calculations & Other | | | | | |
|----------------------|------|---------|--------|--------|-------|
| Controllers | | | | | |
| Name | Type | Address | Status | Alarm | Value |
| GN 1 | GN | 1 | Online | Normal | 1 |
| Action | | | | | 1 |
| GN 2 | GN | 2 | Online | Normal | 1 |
| Action | | | | | 1 |
| GN 3 | GN | 3 | Online | Normal | 1 |
| Action | | | | | 1 |
| GN 4 | GN | 4 | Online | Normal | 1 |
| Action | | | | | 1 |
| GN 5 | GN | 5 | Online | Normal | 1 |
| Action | | | | | 1 |
| GN 6 | GN | 6 | Online | Normal | 1 |
| Action | | | | | 1 |
| GN 7 | GN | 7 | Online | Normal | 1 |
| Action | | | | | 1 |

Calculations & Other

If any calculations have been defined in the AK-SM system, alarms can be associated with these. Use the Calculations tab to set appropriate alarm levels and actions.

6 Control tab

The control tab is the central configuration page for your control requirements. It lays out the different application areas and allows the Commissioning Engineer to define what applications are on site. Once the application areas are defined on this page, more detailed commissioning is done in the dedicated application tabs (covered in following section). Note that depending on your license version, different applications may be visible (or not). Please also note that the SM provides the ability to configure centralized or de-centralized control. **Centralized** control is where your SM has the control logic built in and uses Danfoss I/O to provide refrigeration control. **De-centralized** is the control method via the use of Danfoss Pack and case controllers

For de-centralized control, ensure the control type is set to your required controller type (via drop down menu)

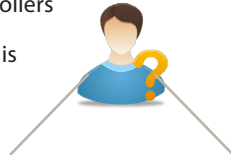

For centralized control, ensure the control type is set to IO (input/output). This alerts the SM that you wish to use Danfoss Board and Point configuration for your refrigeration application

Location: Configuration > Control

| Control | |
|---------------------------|------------------------|
| Name | Value |
| Show only scanned devices | No |
| Refrigeration | |
| Dewpoint method | Calc Dewpt |
| Humidity sensor to use | Inside RH 1 |
| Number of racks/packs | 1 |
| Pack 1 | AK-PC730-021x 080Z0118 |
| Number of drives | 0 |
| Number of circuits | 0 |

De-Centralized

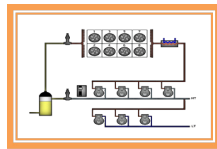

Pack & Case

Centralized

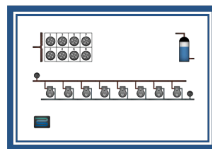

Rack I/O

| Refrigeration | |
|------------------------|-------------|
| Dewpoint method | Calc Dewpt |
| Humidity sensor to use | Inside RH 1 |
| Number of racks/packs | 1 |
| Rack (A) | AK-I/O |
| 2 stage system | No |
| No of suction groups | 5 |
| Condenser type | Air cooled |

Show only scanned devices:

Select 'yes' if your controller devices are already on the network, with valid addresses and connected to the AK-SM. By setting to 'yes' and after a network scan (covered in next section) only discovered devices will be shown in the drop down boxes. If your controllers are not yet on the network, keep this selection to no.

Number of Racks / Packs (max 12):

Enter the required amount of suction groups.

Rack type (Use I/O selection for centralized control, select controller type if using de-centralized)

Location: Configuration > Control

| Control | |
|---------------------------|-------------|
| Name | Value |
| Show only scanned devices | No |
| Refrigeration | |
| Dewpoint method | Calc Dewpt |
| Humidity sensor to use | Inside RH 1 |
| Number of racks/packs | 1 |
| Rack (A) | AK-I/O |
| 2 stage system | No |
| No of suction groups | 5 |
| Condenser type | None |
| HVAC | |
| Number of HVAC units | 0 |
| Lighting | |
| Number of lighting zones | 0 |
| Misc | |
| No. of relay outputs | 0 |
| No. of sensor inputs | 0 |
| No. of on/off inputs | 0 |
| No. of variable outputs | 0 |
| Energy | |
| Number of meters | 0 |
| Leak | |
| Number of leak detectors | 0 |
| Manager's Override | |
| Number of overrides | 1 |

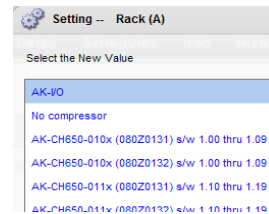

AK IO = built in control via AK I/O

No Compressor = No Compressor control

Device selection = select required controller

Note: Variable Speed can be selected as a pack controller.

Suction groups (Suction group or Evaporator control)

Add your required quantity of suction groups (centralized logic) OR enter how many evaporator controls are available under your Pack (de-centralized)

Note: suction group / evap configuration is then done under the Refrigeration tab

The following screen shots below represent an example of de-centralized configuration (Pack and Case control). The AK-SM has been configured for two pack controllers (AK-PC 730 and the AK-PC 840), with 5 Evaporator controllers under each pack. Selection for each Pack controller was made via the pop up box that appears when the Rack line is double clicked.

Location: Configuration Control

Control Refrigeration Misc Energy Leak Light HVAC

| Control | |
|---------------------------|------------------------|
| Name | Value |
| Show only scanned devices | No |
| Refrigeration | |
| Dewpoint method | Calc Dewpt |
| Humidity sensor to use | Inside RH 1 |
| Number of racks/packs | 2 |
| Pack 1 | AK-PC730-020x 080Z0119 |
| Number of drives | 0 |
| Number of circuits | 5 |
| Pack 2 | AK-PC840-023x 080Z0115 |
| Number of drives | 0 |

Double click to select your required Pack device

Once the Pack controllers have been defined and the number of case controllers under each pack have been set, continue to the Refrigeration tab for detailed configuration.

Location: Configuration Control Refrigeration

Control Refrigeration Misc Energy Leak Light HVAC

Rack Suction Circuits Condenser Drives Rail Heat Addresses Schedules

First, navigate to the 'Address' tab. Enter a valid network address, corresponding to the address already set in the field controllers.

Note: If your field controllers have already been configured with the relevant parameters set, you may wish to perform an 'Upload'. This function forces the AK-SM to pull back the controller settings and thus synchronize the AK-SM database. Only use the 'Download' function if you have finished controller configuration on the AK-SM and you wish then to send these settings 'down' to the controller.

A one click option for this (upload/download) can be found under the Configuration->Network Nodes tab

Location: Configuration Control Refrigeration Addresses

Controllers Relays Sensors On/Off Inputs Variable Outputs VLT

Pack 1 **Controllers**

| Name | Value |
|------------------------|----------------|
| Pack 1 AK-PC730-020x | Pack 1 |
| Address | 0 |
| Download | |
| Upload | |
| My custom name not cfg | My custom name |
| Address | 0 |
| Download | |
| Upload | |
| meat case not cfg | meat case |
| Address | 0 |
| Download | |
| Upload | |
| T&A Case not cfg | T&A Case |
| Address | 0 |
| Download | |
| Upload | |
| Circuit AA4 not cfo | Circuit AA4 |

Set a custom name for your control devices

Enter address that matches the physical address in the pack and case controllers

See above note about Download / Upload

Once all the addresses and custom naming is complete escape out of the addresses menu and navigate to the 'Suction' tab. This will allow for configuration of the Pack Controller(s). Use the drop down (Suction) menu to access each Pack controller and the corresponding menus. Please note that any online controller devices will invoke a dialogue box which asks if you wish to retrieve the data from this controller. This dialogue box is intended to direct the choice of either uploading data from a controller (overwriting any previous settings held in the AK-SM database) or not. If you have existing controllers on the network which have already been configured, choose the upload option (this need only be done once for each controller you view).

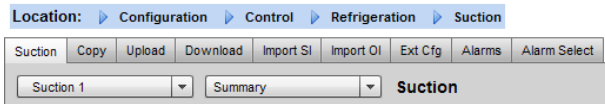

| Name | Value |
|----------------------------------|------------------|
| Name | Pack 1 |
| Suction Optimization | No |
| Suction I.D | Suction |
| User File | None |
| Evap shutdown when injection off | No |
| * Main switch | Off |
| * Cap. control mode | 0: MAN |
| * Manual capacity % | 0 % |
| * Po Reference mode | 0:Ref+NiteOffset |
| * Po Setpoint | -112.0 'F |
| * ++Zone delay s | 0 sec |
| * +Zone delay s | 0 sec |
| * +Zone band K | 0.2 'F |
| * Neutral zone K | 0.0 'F |
| * -Zone band K | 0.2 'F |
| * -Zone delay s | 0 sec |
| * --Zone delay s | 0 sec |
| * Kp Po | 0.1 |

Controller menu selection. Use this drop down list to access the different controller menus.

Controller parameters, to modify or change double click line and press the enter key. The new value will be sent to the controller*

*Controller must be online
*Some controller types require the main switch (R12 parameter) to be off before certain changes can be made

i When to use Upload / Download function:

The AK-SM holds a database in which all the system configuration is held. This includes any actual controller devices connected or just devices that have been selected ready for configuration. It is important to recognise when to perform an upload or download function so that any preset configuration is not overwritten by automatic upload by the AK-SM.

Upload

This function may be required where the case and pack controllers have already been configured and all parameters are set according to customer specifications. In this instance the need is to typically perform an upload function, thus updating the AK-SM database to fully reflect the controllers commissioned settings. Once this has been done, changes to the controller settings can be done directly from the AK-SM.

Download

The opposite to this would be where the controller devices have not been set per customer specification and the AK-SM should be used as the commissioning tool or window into the controllers. By navigating through all the controller screens in the AK-SM it is possible to configure the controller parameters and then send these setting to the connected controllers via the download function.

Copy function

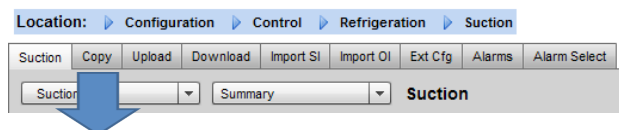

To aid the commissioning process, the AK-SM offers a settings copy function which can be used to copy one device settings and alarm configuration to other (similar) device(s). This function works when copying settings to and from same controller version / type devices. The procedure described below is one example of the copy /paste function.

Use the Copy tab to open the copy page, where any same controller type devices can be copied to. The actual device page will act as the copy base, so ensure the correct circuit is selected (in the drop down list). Select **all** or **individual** controllers that will be copied to, then press the copy to line.

- i** The copy function copies controller parameters etc from once device to the AK-SM database, to complete the operation the (copied) settings need to be **downloaded** to the required controllers.

The Global download function can be seen under the Network Nodes -> Download section

Import SI | OI function

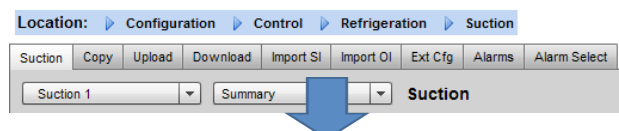

Use the **Import SI (Sensor Input)** and **Import OI (On/Iff)** function to gain access to 'generic' controller (Evap & Pack) parameters that are normally not accessible for alarm / logging / Boolean use. This function can be used to alarm on specific parameters not in the factory alarm list and / or can be used to import controller parameters in the Boolean logic calculator. Up to sixteen points can be selected per controller. This function extends the flexibility of controller support in the AK-SM and opens up the generic controllers parameter list for more customer specific needs. The following steps highlight the procedure in 'Importing'

From the import page(s) double click an import line to present a pop up box that shows all available parameters. Select the parameter that you wish to 'import' from the controller (you may give it a custom name).

In the example below, the parameter Po Set point has been selected. This parameter can now be seen in the miscellaneous calculator.

The screenshot shows a table with the following data:

| Name | Value |
|------------|-------------------|
| Import #1 | 001:1 Po Setpoint |
| Name | 001:1 Po Setpoi |
| Type | Temperature |
| Import #2 | Not configured |
| Import #3 | Not configured |
| Import #4 | Not configured |
| Import #5 | Not configured |
| Import #6 | Not configured |
| Import #7 | Not configured |
| Import #8 | Not configured |
| Import #9 | Not configured |
| Import #10 | Not configured |

Extended Config function

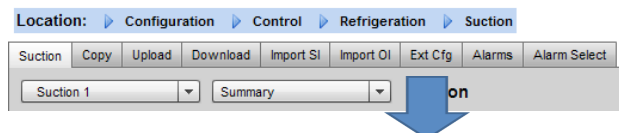

Extended configuration (changing what parameter is seen in the System View, Dashboard & Device detail status)

Using the extended configuration tab the factory standard parameter that is used for 'System View' status can be changed. This feature is useful in giving the end user more flexibility in showing the relevant sensor at the system and device detail views. By changing the **overview value** the AK-SM will then display the new selected parameter or status in the system view, Dashboard and device detail pages.

Alarms and Alarm Select

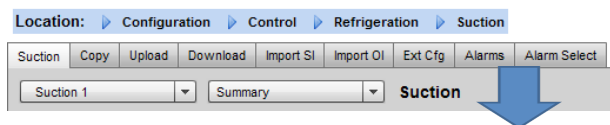

Use the Alarm tab to define the alarm actions associated with this device. Use the Alarm select tab to select up to 300 alarm points (max 300 per AK-PC controller)

Configuration -> HISTORY

The AK-SM history section allows the collection and recording of control parameters, values and status. The central history function allows up to 600 'points' to be configured, a point being a temperature, pressure, status, relay, etc. The collection of history allows further analysis using the AK-SM or remote web browser, where a graphical representation of this data can be made.

To configure history, navigate to the Setup tab (Configuration->History). The following setup lines are visible;

Auto Configure History: Use this function to auto select typical points needed for logging (the AK-SM will select key points in the Refrigeration, HVAC, Lighting and Misc control areas. Manual configuration can be done to override these selections or add more as required.

Clear History Configuration: Use this function to clear history configuration (points selected for history & the frequency of samples)

Clear History log: Use this function to clear stored history in the AK-SM

Start / Suspend History: Once the relevant points have been selected for history collection (using either the Auto history, manual or a combination of both) press this line to Start the collection. Press again to Stop collection

Status: Displays the current status of history collection (Collecting or Suspended)

No of Configured datapoints: Displays the number of configured history points (max 600)



Note: Ensure the correct time & date are set in the AK-SM. Make sure the history collection function is running to ensure the collection of datapoints. Use the 'Start History' line and check that the status reflects 'Collecting'

| Location: Configuration > History | |
|---|-----------|
| Setup Controllers Relays Sensors On/Off Inputs Variable Outputs Other | |
| Setup | |
| Name | Value |
| Auto Configure History | |
| Clear History Configuration | |
| Clear History Log | |
| Start History | |
| Status | |
| No. of Configured Datapoints | Suspended |
| Generic | 11 |
| Sensor Inputs | 8 |
| On/Off Inputs | 1 |
| Relay Outputs | 0 |
| Variable Outputs | 0 |
| Utility Meter | 0 |
| VLT | 0 |
| Other Datapoints | 2 |

Auto Configure History

When selecting the auto configure history function the AK-SM presents the option to select the history collection sample rate.

These can be later changed & modified under the relevant history device type (Controllers/Relays/Sensors/On/Off/Variable/Other)

Configuration -> HISTORY

Controllers

If any controllers are configured for history collection, these can be seen in the **'Controllers'** tab. The example below shows a evaporator controller with the various control groups accessible via a drop down menu. Any auto history settings will be seen in these controller group lists, manual configuration of any parameter can be done in this page.

| Location: Configuration > History | |
|---|--------|
| Setup Controllers Relays Sensors On/Off Inputs Variable Outputs Other | |
| Pack 1 All parameters Controllers | |
| Name | Value |
| 100: --- Ctrl. state | 01 Min |
| 100: r12 Main Switch | Off |
| 100: r28 SetPoint | 01 Min |
| 100: r29 Ref | Off |
| 100: r30 RefMax | Off |
| 100: r31 RefMin | Off |
| 100: r32 Adjust Pc | Off |
| 100: r33 Ctrl. mode | Off |
| 100: r56 Min tm K | Off |
| 100: --- Req. Cap % | 01 Min |
| 100: r64 Heat SP | Off |
| 100: r65 Ref.Ramp K/m | Off |
| 100: r68 ExtRefMax | Off |
| 100: r69 ExtRefMin | Off |
| 100: r72 Adjust S7 | Off |

Navigate and select appropriate points for history collection, via the drop down menu selector. Double click a required line, a pop up selection box allows the choice of sample rates; **1,2,10,30 mins**
1 Hr

Relays, Sensors, On/Off Inputs, Variable Outputs & Other

Depending on the defined control criteria, other points may be viewed and modified under the respective tabs.

Service Tool Support

Your AK-SM supports the Danfoss Service Tool (version 3.23 and above). The Service Tool (CT) must be connected via an IP interface. Once an connection is established the ST will show the AK-SM and all AK2 platform devices. Note that non AK2 platform based devices will not show up in the ST device list.

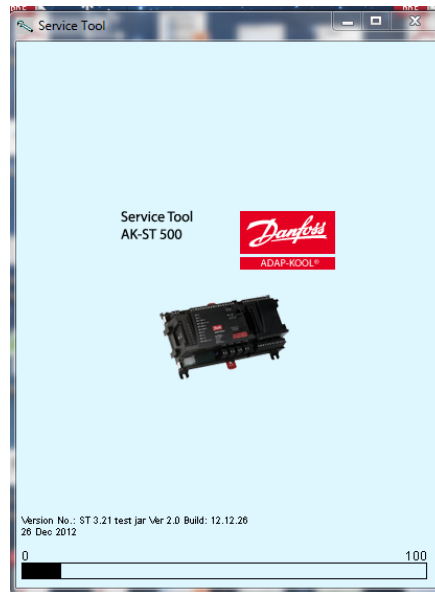

When creating a new connection in your ST make sure you select TCP/IP channel.

Assuming the factory default user name and password, enter **Supervisor** for the Destination name **12345** for the Pass code

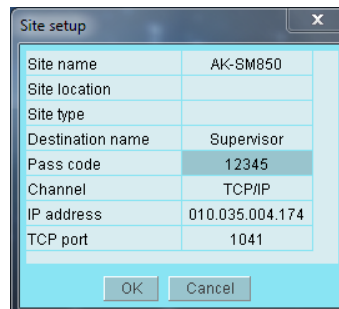

Once connected, navigate to your required controller in the available list. Access to all AK2 parameters is available via this connection.

General navigation, operation and use (via web)

Once your AK-SM has been configured, general navigation and daily use is done via the Dashboard screen. The Dashboard screen acts as the central system home page, where further system details can be reached. The Dashboard and subsequent device screens have been developed to provide an easy to use navigation environment for the user, where typical status and setting can be found.

Connecting to your AK-SM:

Using a standard web browser or your StoreView Desktop application, enter your AK-SM IP address

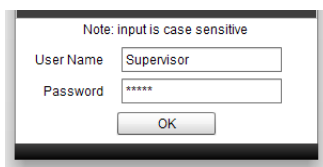

The factory default User name & password:
 User Name: Supervisor
 Password: 12345



To guarantee the best experience when connecting to your AK-SM, ensure you PC has the latest version of Adobe® Flash®

Dashboard view:

Once the correct user name and password has been entered the Dashboard screen will load. The Dashboard screen will only reflect what your application configuration has been set to. For example, if your application does not have any HVAC configured the Dashboard will not show the HVAC panel. Dashboard panels are automatically generated depending on the configuration, no user action is required to build the panels.

Translation Tool (used for local language translation)
 Download Report (system report of configuration)
 Log Off

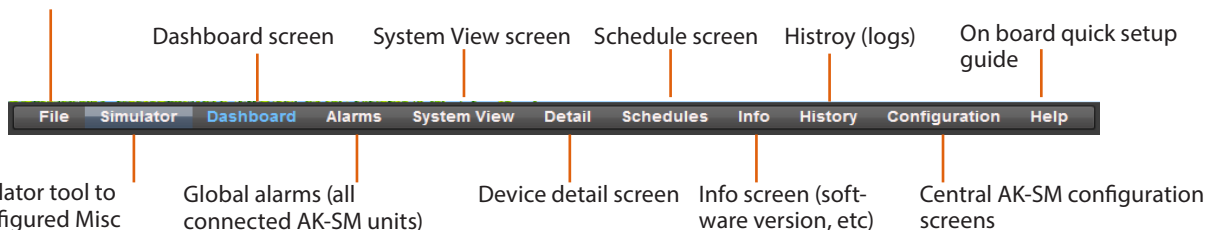

Use the simulator tool to simulate configured Misc points

Global alarms (all connected AK-SM units)

Device detail screen

Info screen (software version, etc)

Central AK-SM configuration screens

| Unit | Device Name | Alarm Type | Occurred |
|------|---------------|----------------|------------------|
| 0 | Zone Temp 2-1 | High zone temp | 12/20/12 01:57PM |

| Unit | Name | Status | Value | Setpoint | Alarm |
|------|-------------|--------------------|---------|----------|-------|
| 0 | Pack 1 | | | | No |
| 0 | Suction 1 | (s15) De Err | Err | No | No |
| 0 | Circuit AA1 | (s0) Non 0-No HAI | 35.6 °F | No | No |
| 0 | Circuit AA2 | (s0) Non -328.0 °F | 35.6 °F | No | No |
| 0 | Circuit AA3 | (s0) Non -328.0 °F | 35.6 °F | No | No |
| 0 | Circuit AA4 | (s0) Non -328.0 °F | 35.6 °F | No | No |
| 0 | Circuit AA5 | (s0) Non -328.0 °F | 35.6 °F | No | No |
| 0 | Circuit AA6 | (s0) Non -328.0 °F | 35.6 °F | No | No |
| 0 | Circuit AA7 | (s0) Non -328.0 °F | 35.6 °F | No | No |

| Unit | Name | Status | Value | Alarm |
|------|--------|----------------|---------|-------|
| 0 | Unit 1 | Fan proof fail | 72.9 °F | No |
| 0 | Unit 2 | Fan proof fail | 52.7 °F | Yes |

| Unit | Name | Value | Alarm |
|------|--------|-------|-------|
| 0 | Zone 1 | On | No |
| 0 | Relay1 | On | No |

| Unit | Name | Value | Alarm |
|------|---------------|-------|-------|
| 0 | Sensor 1 | Off | No |
| 0 | Sensor 1 | 26.1 | No |
| 0 | Sensor 2 | 36.7 | No |
| 0 | Sensor 3 | 20.3 | No |
| 0 | Heater On/Off | Off | No |
| 0 | Misc VarOut 1 | 0.0% | No |
| 0 | Leak 1 | 527% | No |

| Unit | Name | Value | Alarm |
|------|---------|---------------|-------|
| 0 | Meter 1 | 0.0 kWh | No |
| 0 | Meter 2 | OffLn 0.0 kWh | Yes |
| 0 | Meter 3 | OffLn 0.0 kW | Yes |
| 0 | Meter 4 | OffLn 0.0 kW | Yes |

Once the correct user name and password has been entered the Dashboard screen will load. The Dashboard screen will only reflect what your application configuration has been set to. For example, if your application does not have any HVAC configured the Dashboard will not show the HVAC panel. Dashboard panels are automatically generated depending on the configuration, no user action is required to build the panels.



Upon the Dashboard loading, if any active alarms are present the built in alarm buzzer can be heard. To silence the alarm press the silence button. This does not acknowledge or clear any alarms.

Managing alarms:

Any active alarms will be shown in the Dashboard alarm panel. To view more details regarding the alarm double click the relevant alarm line. A alarm info box will appear with further details regarding the alarm. In addition to more information, the info box also allows the authorized user to Mute/Acknowledge the alarm and to jump to the device detail screen.

Alarm info pop up

| | |
|---------------|---------------------------------------|
| Description | High sensor value |
| Point | Outside temp |
| Address | 01-1.1 |
| Setting | Alarm if above 122.0°F for 15 minutes |
| Current Value | 497.9 °F |
| Occurred | 12/21/12 09:39AM |
| Acknowledged | No |
| Cleared | |
| Alarm Level | Normal |
| Alarm Action | 0 |

| Name | Status |
|-----------|--------------|
| Network 2 | Not selected |
| Printer | Not selected |

Use the Mute/Ack button to acknowledge the alarm. When pressed the alarm will 'move' to the Acknowledge list

Click the detail button to jump to the device detail screen

To view all system alarms (known as global alarms) use the Alarms tab (found on the main menu)

Global alarm screen

Global acknowledge list Status and Service screens

Export Alarms

Service screen

Under the service screen tab, test alarms can be configured and set.

| Name | Value |
|-------------------------------------|--------|
| System Test Alarm | Normal |
| Action | 1 |
| Press to send test alarm now | |
| Auto Test | None |
| Suspend alarm generation | No |
| Press to clear the alarm log | |
| Press to delete alarm configuration | |
| Internal relay | Auto |

Device detail:

Whilst the Dashboard screen will show basic asset information (AK-SM unit address, Asset Name, Value, Status and alarm), more detailed information can be found by double clicking an asset line in the Dashboard. The resulting device detail screen will reflect more details and settings. The device detail screen is designed to provide key status and operational settings for the selected device. Easy navigation to other assets is done via the navigation tree. The screen image below highlights some of the main areas of the device detail screen.

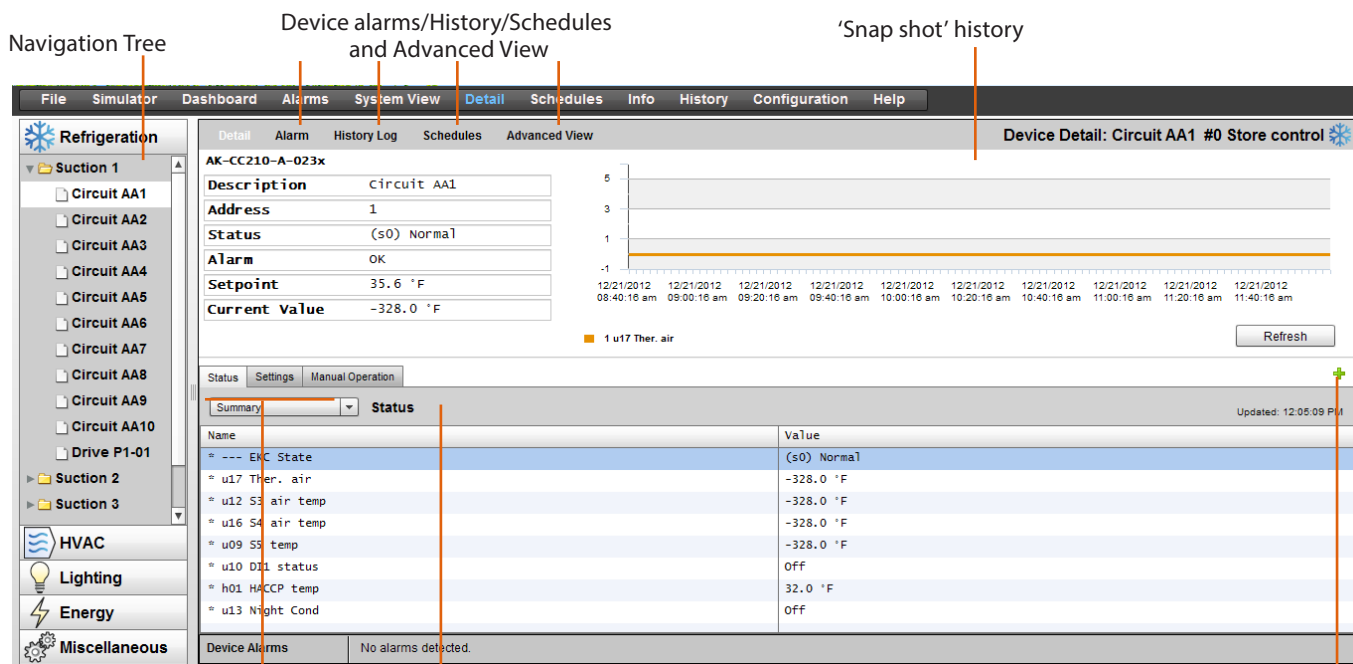

Status | Settings | Manual Operation tabs

Full screen button

Status

Under the status tab, common read only datapoints are shown

Settings

Under the settings tab, read and write values can be shown.

Double click a line to make changes (if authorized)

Manual Operation

Under the Manual Operation tab, key user override functions are available

Use the 'Advanced view' screen to access Measurements and Settings side by side. This screen is useful to access all read/write parameters for the particular controller

Advanced screen

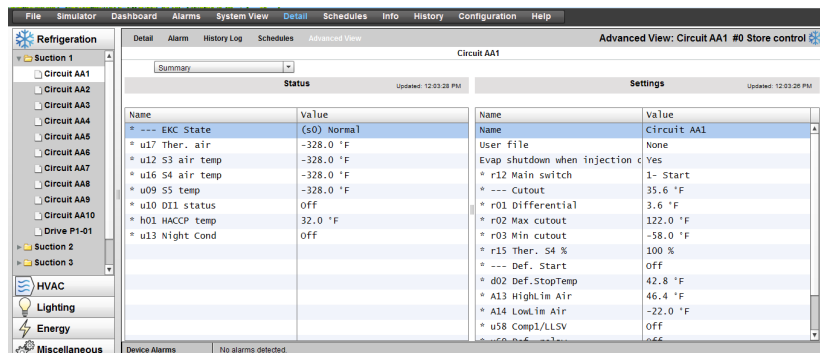

System view:

The system view provides a generic yet graphical view of your configured controls.

The same principle of the navigation tree can be seen in the left side of the screen. The system view screen shows any configured Rack or Pack, with associated evaporator circuits. To see additional information, hover your mouse pointer over an icon, a pop up box will appear showing additional information. To view additional information and gain access to settings click the 'show Detail' button. A dashboard will slide across, where a Status, Settings and Manual operation can be seen. Simply click an asset to highlight and the detail table will update with reference to this selected device. Once complete with the device settings, close the dashboard by clicking the 'Hide Detail' button.

System View (Refrigeration)

Gain access to more details via the 'Show Details' button

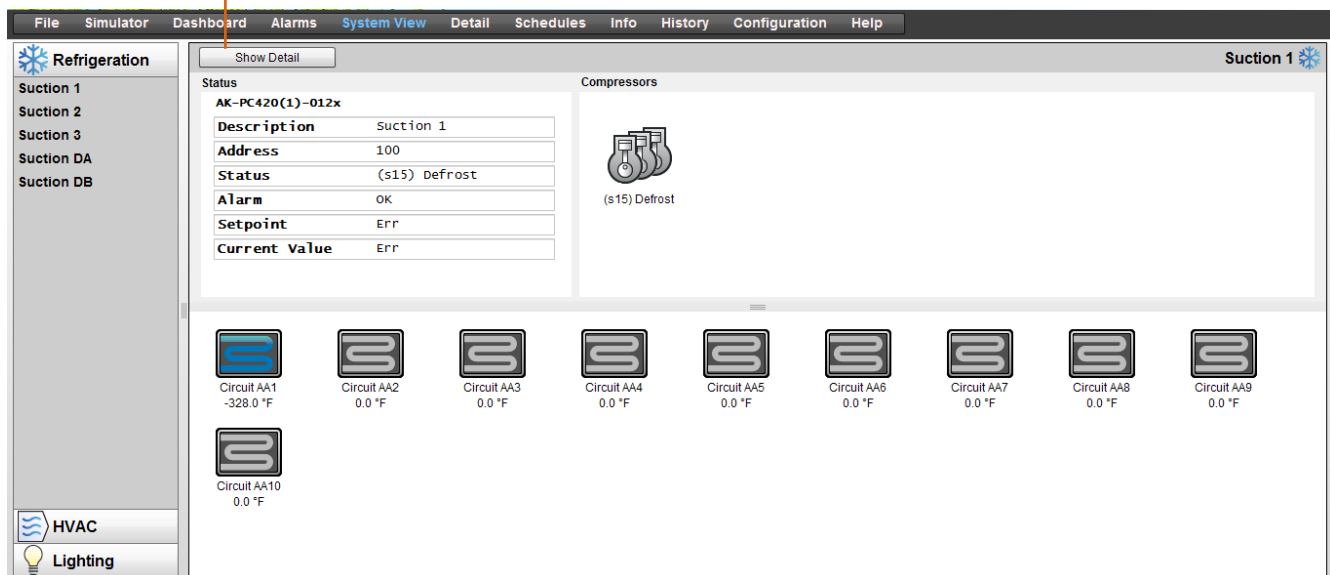

Schedule view:

The schedule view provides a system wide view of schedules (previously configured) in your AK-SM or host of controllers. The following schedules are currently supported under the schedule view;

- Shutdown (Generic controllers - i.e. AK-CC)
- Defrost (Generic controllers - i.e. AK-CC)
- Case Lights (Generic controllers - i.e. AK-CC)
- Night Setback (Generic controllers - i.e. AK-CC)

If a host network of AK-SM units are configured, a full system view can be seen by selecting the folder icon, for a (AK-SM) unit display click the relevant heading under the folder view. The schedule screen includes a mouse hover over, that indicates (per circuit) the schedule times.

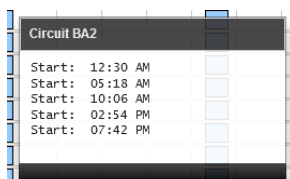

Change the graphical view to text (table) form, Print, save as PDF or save as CSV

| | 12 | 1 | 2 | 3 | 4 | 5 | 6 | 7 | 8 | 9 | 10 | 11 | 12 | 1 | 2 | 3 | 4 | 5 | 6 | 7 | 8 | 9 | 10 | 11 |
|--------------|----|---|---|---|---|---|---|---|---|---|----|----|----|---|---|---|---|---|---|---|---|---|----|----|
| Circuit BA1 | | | | | | | | | | | | | | | | | | | | | | | | |
| Circuit BA2 | | | | | | | | | | | | | | | | | | | | | | | | |
| Circuit BA3 | | | | | | | | | | | | | | | | | | | | | | | | |
| Circuit BA4 | | | | | | | | | | | | | | | | | | | | | | | | |
| Circuit BA5 | | | | | | | | | | | | | | | | | | | | | | | | |
| Circuit BA6 | | | | | | | | | | | | | | | | | | | | | | | | |
| Circuit BA7 | | | | | | | | | | | | | | | | | | | | | | | | |
| Circuit BA8 | | | | | | | | | | | | | | | | | | | | | | | | |
| Circuit BA9 | | | | | | | | | | | | | | | | | | | | | | | | |
| Circuit BA10 | | | | | | | | | | | | | | | | | | | | | | | | |

History (Logs)

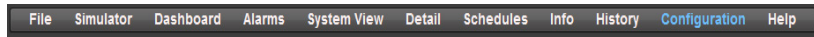

To access your AK-SM history, select the history tab.
Upto 8 datapoints can be viewed at any given time on the history screen.

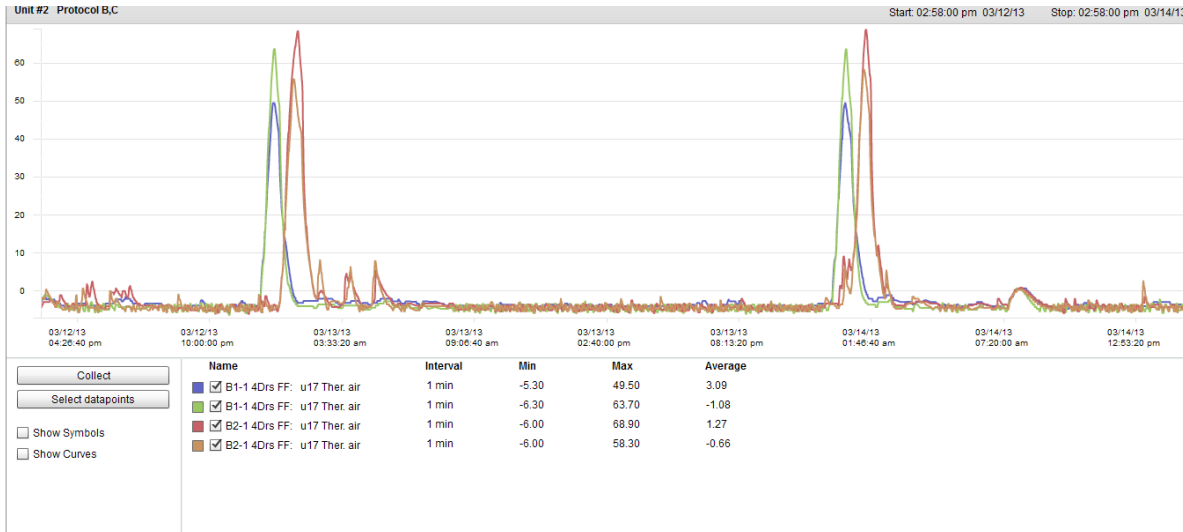

History Tool bar

When viewing data in the history view the tool bar has a set of functions to enable various actions to be performed.

Export history function

Export to .hst or csv file format. Saving the collected history points (as .hst) will allow the user to re-load these at a later date (via the 'load history from file' button)

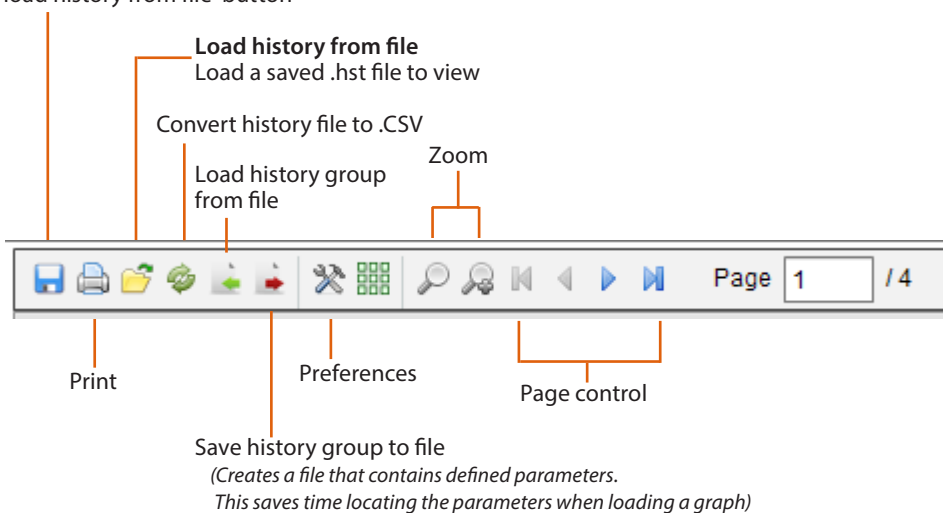

Collecting and viewing history

1/ from the history page, press the collect button

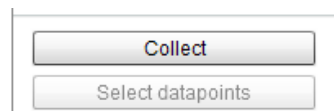

2/ Select the required datapoints and time/date range. Multiple points can be collected but only 8 can be later shown in the history screen at any given time. After the datapoints have been downloaded, a dialogue box will appear which provides two options:

- Select points to draw
- Save to .hst file (for later view)

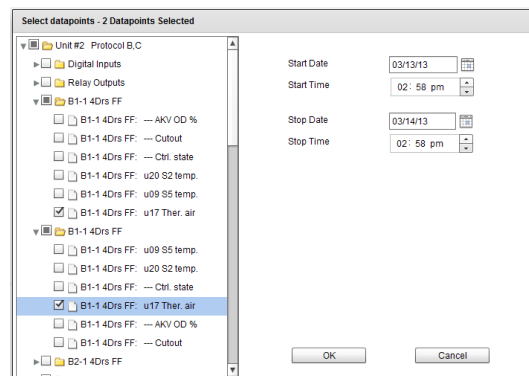

3/ The graph will be presented for view and analysis. Use the zoom buttons or hold the left mouse button and hold for zoom area. Moving the mouse pointer will show a tool tip with point description, time/date and value.

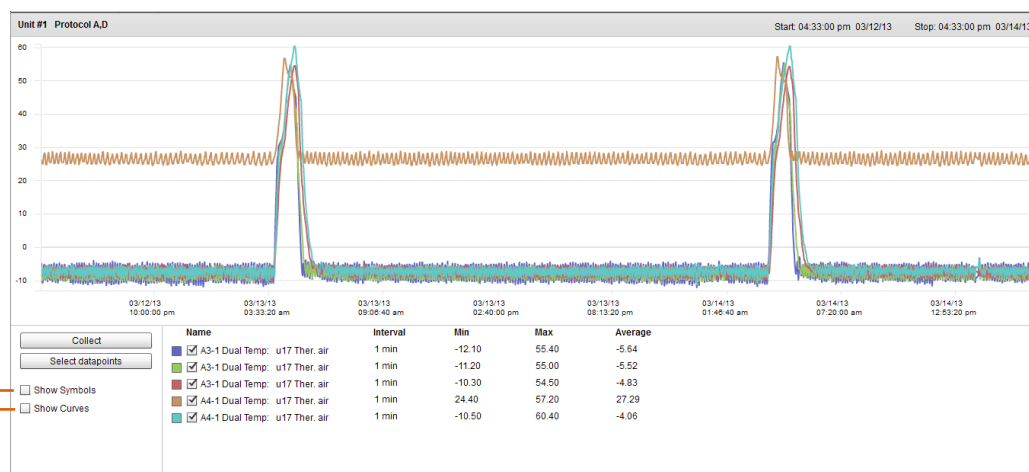

Show curves (provides a computed rounding of the analog curve)

Show Symbols (each symbol represents a sample)

Save History Group to file (saving time for frequent datapoint selections)

This feature allows the user to save a set of history datapoints. Typically this feature would be used when a set of datapoints is frequently needed to be loaded and viewed. Once the datapoints are saved, this history group can then be easily loaded - thus saving time in selecting datapoints.

Load History Group from file

Use this feature to load any previously save datapoint groups. When opening the history group file the system will prompt for the file location. Once loaded a 'select datapoint' box will appear with the datapoints already pre-selection

Export History data

This feature allows the user to export the previously collected history data. A pop up window asks the user to select a file format, the following formats are possible;

- .hst (Danfoss history file format)
- .csv (Excel compatible spreadsheet)

Saving any collected history as a file allows for future loading and view, use the 'Load history from file' button to load any saved history files.

Updating Software (via USB Flash Drive)

The AK-SM can read & write to USB flash based drives. Upon insertion (or via main menu option 7), the USB menu window will be shown (for DIN units read following section). A typical example of the resulting pop up screen can be seen below, with descriptions for each option. The menu reflects supported files located on the USB memory stick, and may vary from the example below. Ensure relevant software files are located in the USB root directory. When updating your AK-SM it is recommended to first update the 'Bootloader' (if specified), followed by the Master Application Image (MAI). The MAI contains AK-SM firmware, EDF and Web files needed.

Flash Drive options

- Option 1: The Bootloader file can be updated via USB connection.
- Option 2: The Application software can be updated via USB connection.
- Option 3: Master Application Image (MAI). This is the recommended file to update your AK-SM, it contains firmware, EDF and Web files
- Option 4: Save AK-SM database via USB
- Option 5: Load AK-SM database via USB
- Option 6: Save report (txt file format, containing main system configuration details)
- Option 7: Save Report (txt file format, containing configured system status, not full configuration details)

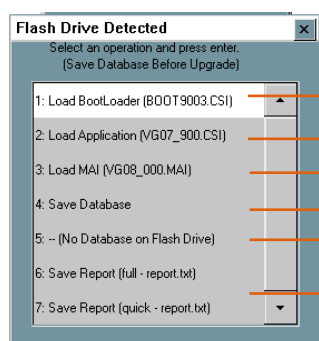

- 1: Load BootLoader (BOOT9003.CSI) — Bootloader file- used for AK-SM system file management
- 2: Load Application (VG07_900.CSI) — AK-SM Application code (does not include EDF/HTML files)
- 3: Load MAI (VG08_000.MAI) — Master Application Image (includes firmware, EDF and HTML files)
- 4: Save Database — Save AK-SM database (does not include any graphic view files)
- 5: -- (No Database on Flash Drive) — Load a SM-800 database
- 6: Save Report (full - report.txt) — Save AK-SM system configuration as .txt file
- 7: Save Report (quick - report.txt)

| File type / Description | Method of loading |
|--|-----------------------------|
| Boot.csi / Boot Loader file (required for system file management) | USB Flash drive |
| CSI / Application code for AK-SM. Includes all system EDF files | USB Flash drive or RMT tool |
| MAI / Master Application code for AK-SM. Includes all firmware, EDF and Web files | USB Flash drive or RMT |
| FAI / Factory Application Image | USB |

Remotely Upgrading you AK-SM unit - what is the FAI file

Your AK-SM has the ability to be upgraded via a remote connection (RMT). Upgrading via remote offers several advantages, the obvious one being time saving. However, this is increased risk when performing remote upgrades (i.e. quality of connectivity, power..). Software version 03_051 (and above) comes with an additional extension, FAI (Factory Application Image). The FAI software file contains special code designed to support remote software upgrades. The FAI file provides a 'fall back' state, if at any time a later remote upgrade fails or gets corrupted. Rather than leave a unit in an unstable state in the event of a corrupted remote upgrade, the factory image ensures you can always make contact to re-install code again. In addition, the FAI contains the MAI, which also contains all relevant web and EDF files. Via the Info screen, check if your AK-SM unit has a Factory Application installed. For future remote upgrades it is recommended that the FAI is installed if it is not already present in your system. The AK-SM can run without the FAI, with firmware updates being done via the MAI file.

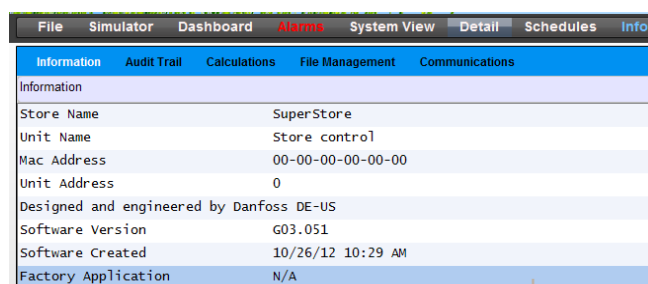

Under the Info->Information tab, check to see if a Factory Application is installed (FAI).
If you intend to perform remote software updates, Danfoss recommends the loading of the FAI file.

Recommended method for upgrading your AK-SM - Boot-loader

The AK-SM bootloader file is a critical file that manages system boot up sequence and system management. The Bootloader can **not** be loaded remotely. Updating the bootloader can be done in application mode (normal AK-SM operation) or when placed in bootloder mode. The following description of how to upgrade your Bootloder version is via normal AK-SM operation mode.

Bootloader

- 1/ Back up current database (via USB flash drive or RMT)
- 2/ Load the latest Bootloader on to the **root directory** of a suitable USB flash Drive and insert in the AK-SM. The Bootloader file is shown under option 1 of the resulting USB pop up window. A progress dialog box will appear, to confirm loading status.
- 3/ Upon finishing the Bootloader file installation the AK-SM will reset. Your AK-SM will reset in Bootloder mode. Manually reset the AK-SM by pressing and holding down the CPU reset button, located behind the front USB access door. The system will now boot into normal application mode.

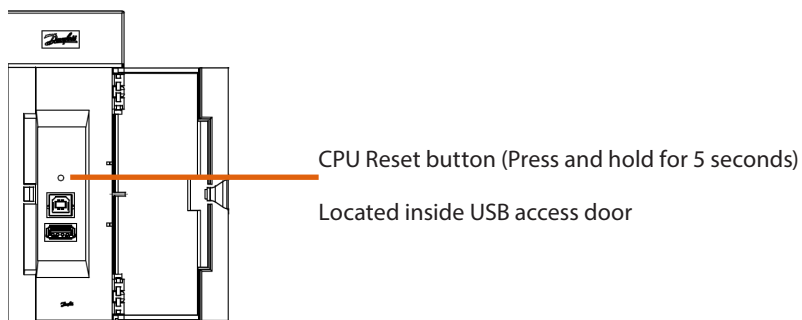

Firmware

Danfoss recommends using the Master Application Image software (MAI), as it contains all relevent files for correct operation (Firmware, Web and EDF). The following steps describe how to update whilst in normal operation mode.

- 1/ Back up current database (via USB flash drive or RMT) if not already done so
- 2/ Load the latest AK-SM firmware (i.e. MAI file) in the **root directory** of a suitable USB flash Drive and insert in the AK-SM. The MAI file should be shown under option 3 of the resulting USB pop up window. Follow on screen instructions.
- 3/ Allow the MAI to fully install and write to system flash memory
- 4/ After a few minutes the unit will reset and return to normal operation, using the latest code.

ENGINEERING
TOMORROW



www.danfoss.com

ADAP-KOOL® Refrigeration Control Systems is a trademark of Danfoss A/S, www.danfoss.com

Danfoss can accept no responsibility for possible errors in catalogs, brochures, or other printed material. Danfoss reserves the right to alter its products without notice. This also applies to products already on order provided that alterations can be made without subsequent changes being necessary in specifications already agreed. All trademarks in this material are property of the respective companies. Danfoss and the Danfoss logotype are trademarks of Danfoss A/S. All rights reserved.