

ENGINEERING
TOMORROW

Danfoss

Application guidelines

Danfoss scroll compressors **DCJ 091-121**

50 Hz - 60 Hz - R410A



ЮГОВ - Проект

інженерно-виробниче підприємство

Офіційний дистриб'ютор
Danfoss в Україні



<http://cc.danfoss.com>

GENERAL INFORMATION.....	4	Manage superheat	21
		Requirement	21
		Evaluate the risk.....	21
		Test, criteria and solutions.....	22
PRODUCT INFORMATION	5	Manage off cycle migration.....	23
Features.....	5	Requirement	23
Overview	5	Evaluate the risk.....	23
How do IDVs work?.....	5	Crank case heater.....	24
Compressor model designation	6	On/off cycling (cycle rate limit)	24
Nomenclature	6	Provide power supply and electrical	
Technical specifications.....	7	protection	25
50-60 Hz data	7	Wiring information.....	25
Dimensions	8	Control logic	26
Single compressors	8	Safety control logic requirements.....	26
Tandem assemblies.....	9	Cycle rate limit requirements	26
Electrical data, connections and wiring	10	Oil management logic recommendations	26
Motor voltage.....	10	Defrost logic recommendations	27
Wiring connections.....	10	Pump-down logic recommendations.....	27
IP rating.....	11	Reduce moisture in the system.....	28
Three phase electrical characteristics	11	Requirements.....	28
Motor protection.....	12	Solutions	28
Approval and certificates	13	INTEGRATION INTO SYSTEMS.....	29
Low voltage directive.....	13	Assembly line procedure.....	29
Machines directive	13	Compressor storage.....	29
Pressure equipment directive.....	13	Compressor holding charge	29
Internal free volume.....	13	Handling	29
SYSTEM DESIGN.....	14	Piping assembly.....	30
Design piping	14	System pressure test and leak detection	30
General requirements	14	Vacuum evacuation and moisture removal	31
Tandem requirements.....	15	Refrigerant charging.....	31
Design compressor mounting	16	Dielectric strength and insulation resistance	
General requirements	16	tests	31
Single requirements.....	16	Commissioning.....	32
Tandem requirements.....	16	Preliminary check.....	32
Manage sound and vibration.....	17	Initial start-up.....	32
Compressor sound radiation.....	17	System monitoring.....	32
Mechanical vibrations.....	18	Oil level checking and top-up.....	32
Gas pulsation	18	Dismantle and disposal	33
Manage operating envelope.....	19	ORDERING INFORMATION	34
Requirement.....	19	Packaging	34
Evaluate the risk.....	20	Ordering codes	35
Test, criteria and solutions.....	20	Accessories.....	37

Danfoss scroll compressors are designed and manufactured according to the state of the art and to valid European and US regulations. Particular emphasis has been placed on safety and reliability. Related instructions are highlighted with the following icons:

 This icon indicates instructions to avoid safety risk.

 This icon indicates instructions to avoid reliability risk.

The purpose of this guideline is to help customers qualify compressors in the unit. You are strongly advise to follow these instructions. For any deviation from the guidelines, please contact Danfoss Technical Support. In any case, Danfoss accepts no liability as a result of the improper integration of the compressor into the unit by the system manufacturer.

Features

Overview

DCJ091-106-121 scroll compressor benefit from an improved design to achieve the highest efficiency and increased life time.

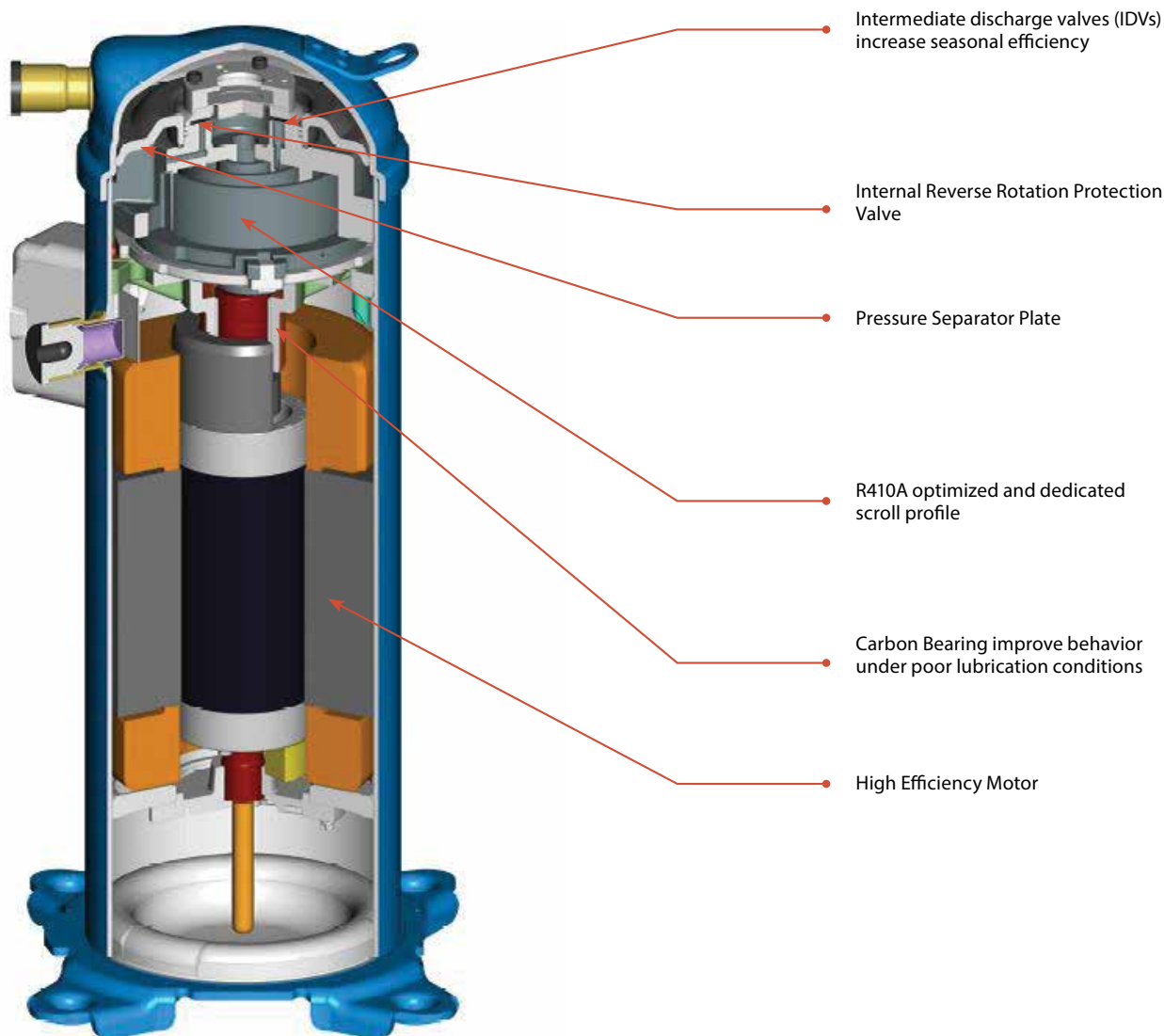

How do IDVs work?

Danfoss Intermediate Discharge Valves (IDVs) are located close to the discharge side of the compressor. They reduce excessive compression of refrigerant under part-load conditions while maintaining the same cooling capacity. The IDVs open when discharge pressure falls below the built-in optimization point. They adapt the effort of the motor to the varying load and pressure conditions in the system, thus reducing the effort of the motor and its electrical consumption and improving the system's seasonal energy efficiency.



Compressor model designation

Danfoss scroll compressor DCJ for R410A is available as single compressor and can be assembled in tandem combinations. The example below presents the compressor nomenclature

which equals the technical reference as shown on the compressor nameplate. Code numbers for ordering are listed in section "Ordering information".

Nomenclature

Type	Size	Motor	Features
DCJ	091	T4L	C6

DCJ: Commercial scroll, PVE lubricant, for R410A

Nominal capacity: In thousand Btu/h at 60 Hz, ARI conditions

Model variation: T: Design optimized for 7.2/54.4°C

Other features

	Oil sight glass	Oil equalisation	Oil drain	LP gauge port	Gas equalisation port
6	None	None	None	None	None
8	None	Brazed	None	None	Brazed

Tubing and electrical connections
C: brazed connections, screw terminals 

Motor protection
L: internal motor protection

Motor voltage code
2: 200-220V/3~/50Hz & 208-230V/3~/60 Hz
4: 380-415V/3~/50 Hz & 460V/3~/60 Hz
7: 575V/3~/60 Hz
9: 380V/3~/60 Hz

GENERAL INFORMATION

PRODUCT INFORMATION

SYSTEM DESIGN

INTEGRATION INTO SYSTEM

ORDERING INFORMATION

Technical specifications

50-60 Hz data

Model	Nominal tons 60 Hz	Nominal cooling capacity		Power input	COP	E.E.R.	Swept volume		Displacement ①		Oil charge		Net weight ②		
	TR	W	Btu/h	W	W/W	Btu/h/W	cm ³ /rev	cu.in/rev	m ³ /h	cu.ft/h	dm ³	oz	kg	lbs	
50Hz	DCJ091	7.5	19670	67114	6360	3.09	10.55	86.9	5.3	15.11	533.6	2.46	84	49	108
	DCJ106	9	23000	78476	7363	3.12	10.66	101.6	6.2	17.68	624.4	2.46	84	49	108
	DCJ121	10	26250	89565	8431	3.11	10.62	116.4	7.1	20.24	714.8	2.46	84	49	108
60Hz	DCJ091	7.5	27084	92437	8393	3.23	11.01	86.9	5.3	18.24	644.1	2.46	84	49	108
	DCJ106	9	31472	107412	9671	3.25	11.11	101.6	6.2	21.34	753.6	2.46	84	49	108
	DCJ121	10	35723	121921	11122	3.21	10.96	116.4	7.1	24.43	862.7	2.46	84	49	108

① Displacement at nominal speed: 2900 rpm at 50 Hz, 3500 rpm at 60 Hz

② Net weight with oil charge

TR: Ton of Refrigeration,

Standard rating conditions:

For 50Hz: Evaporating temperature: 5°C (41°F), Condensing temperature: 50°C (122°F), Superheat: 10K (18°F), Subcooling: 0K (0°F)

For 60Hz: Evaporating temperature: 7.1°C (45°F), Condensing temperature: 54.4°C (130°F), Superheat: 11.1K (20°F), Subcooling: 8.3K (15°F)

EER: Energy Efficiency Ratio

Refrigerant: R410A

COP: Coefficient Of Performance,

All performance data test after run-in 72hrs

Subject to modification without prior notification.

Data given for motor code 4 compressor, for full data details and capacity tables refer to Online Datasheet Generator: www.danfoss.com/odsg

Dimensions

Single compressors DCJ091-106-121

GENERAL INFORMATION
PRODUCT INFORMATION
SYSTEM DESIGN
INTEGRATION INTO SYSTEM
ORDERING INFORMATION

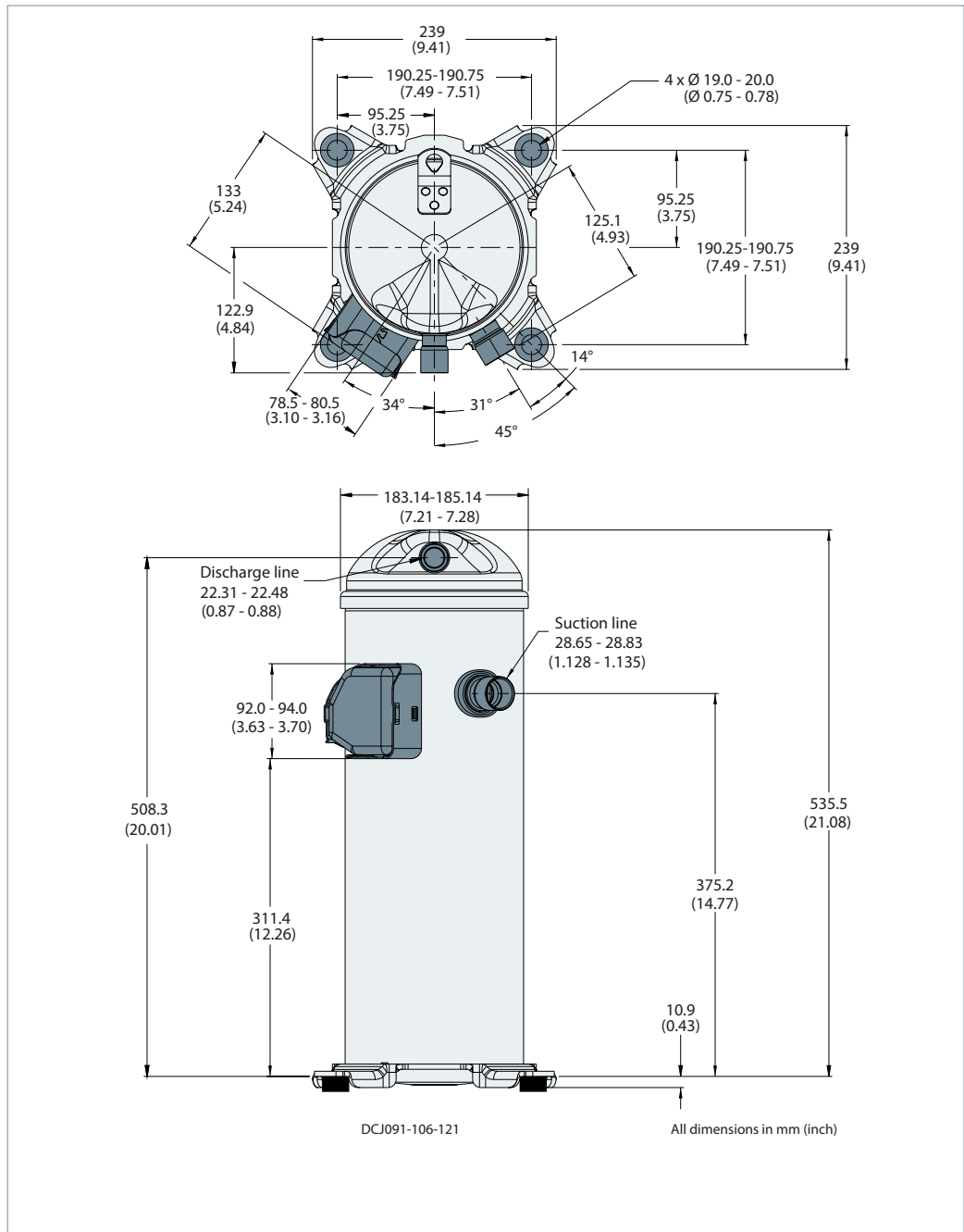

Terminal box

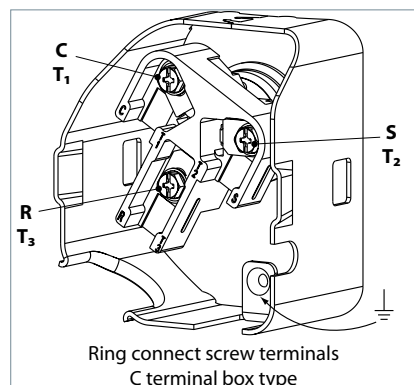

Mounting grommet

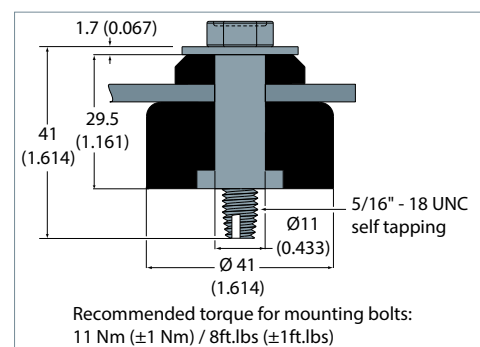

Dimensions

Tandem assemblies

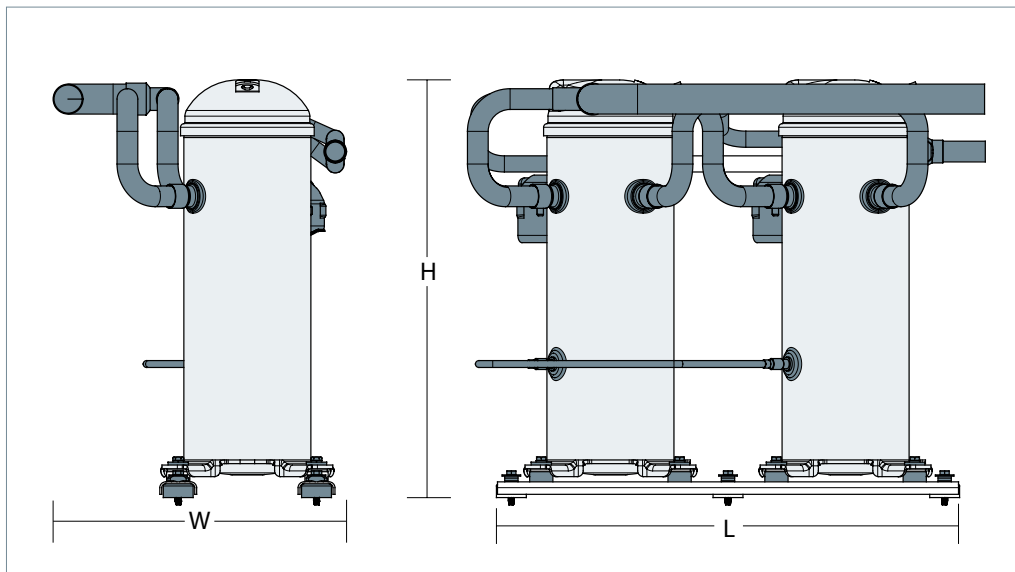

By default, DCJ tandems are not factory-built, just provide tandem version compressors(feature 8).

Tandem model	Composition	L		H		W		Outline drawing number
		(mm)	(inch)	(mm)	(inch)	(mm)	(inch)	
DCJ182	DCJ091 + DCJ091	676	26.6	575	22.6	404	15.9	8556178
DCJ212	DCJ106 + DCJ106	676	26.6	575	22.6	404	15.9	8556178
DCJ242	DCJ121+ DCJ121	676	26.6	575	22.6	404	15.9	8556178
DCJ211	DCJ091 + DCJ121	676	26.6	575	22.6	404	15.9	8556178

Motor voltage

Danfoss scroll compressors DCJ are available in four different motor voltages as listed below.

Motor voltage code		Code 2	Code 4	Code 7	Code 9
50 Hz	Nominal voltage	200-220V-3 ph	380-415V - 3 ph	-	-
	Voltage range	180-242V	342-457 V	-	-
60 Hz	Nominal voltage	208-230V-3 ph	460V - 3 ph	575V - 3 ph	380V -3 ph
	Voltage range	187-253V	414-506 V	517-632 V	342-418V

The maximum allowable voltage imbalance is 2%. Voltage imbalance causes high amperage over one or several phases, which in turn leads to

overheating and possible motor damage. Voltage imbalance is given by the formula:

$$\% \text{ voltage imbalance} = \frac{|V_{avg} - V_{1-2}| + |V_{avg} - V_{1-3}| + |V_{avg} - V_{2-3}|}{2 \times V_{avg}} \times 100$$

V_{avg} = Mean voltage of phases 1, 2, 3.

V₁₋₃ = Voltage between phases 1 and 3.

V₁₋₂ = Voltage between phases 1 and 2.

V₂₋₃ = Voltage between phases 2 and 3.

Wiring connections

Danfoss Scroll Compressors DCJ will only compress gas while rotating counter-clockwise (when viewed from the compressor top). Three-phase motors, however, will start and run in either direction, depending on the phase angles of the supplied power. Care must be taken during installation to ensure that the compressor operates in the correct direction

(see "Phase sequence and reverse rotation protection").

The drawings below show electrical terminal labelling and should be used as a reference when wiring the compressor. For three phase applications, the terminals are labelled T1, T2, and T3. For single-phase applications the terminals are labelled C (common), S (start), and R (run).

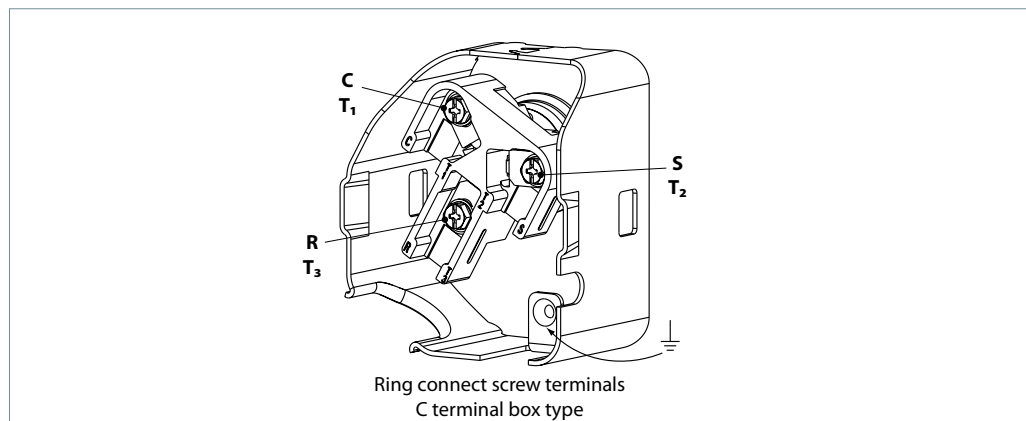

Terminal cover removal

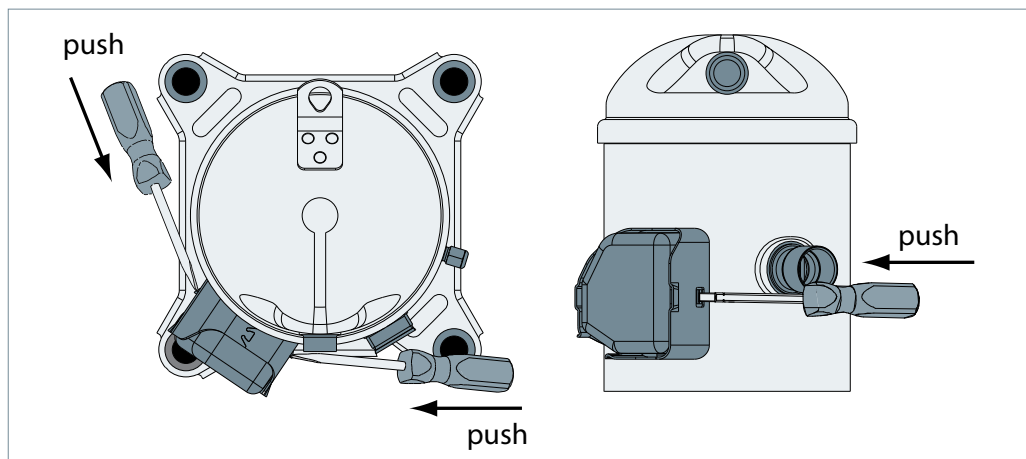

GENERAL INFORMATION

PRODUCT INFORMATION

SYSTEM DESIGN

INTEGRATION INTO SYSTEM

ORDERING INFORMATION

Electrical data, connections and wiring

IP rating

The compressor terminal box according to IEC529 is IP22 for all models. IP ratings is only valid when correctly sized cable glands of the IP rating is applied.

First numeral, level of protection against contact and foreign objects

2 - protection against object size over 12.5 mm (1/2 inch) (fingers of similar)

Second numeral, level of protection against water

2 - protection against dripping water when tilted up to 15°

The IP rating can be upgraded to IP54 with an accessory kit (see section "Accessories").

Three phase electrical characteristics

Compressor model		LRA	MCC	Max. operating current	Winding resistance
		A	A	A	Ω
Motor voltage code 2 200-220 V / 3ph / 50 Hz 208-230 V / 3ph / 60Hz	DCJ091	250	43.5	36.4	0.28
	DCJ106	250	45.0	42.0	0.28
	DCJ121	265	53.0	50.1	0.26
Motor voltage code 4 380-415 V / 3ph / 50 Hz 460 V / 3ph / 60Hz	DCJ091	125	25.0	20.0	1.10
	DCJ106	125	26.0	20.0	1.10
	DCJ121	125	25.0	22.1	1.10
Motor voltage code 7 575 V / 3 ph / 60 Hz	DCJ091	110	17.6	14.0	1.60
	DCJ106	110	18.0	15.4	1.60
	DCJ121	110	20.0	17.8	1.60
Motor voltage code 9 380 V / 3ph / 60 Hz	DCJ091	155	27.6	21.3	0.70
	DCJ106	155	30.0	23.0	0.70
	DCJ121	155	31.0	26.5	0.70

Electrical data, connections and wiring

GENERAL INFORMATION	<p>LRA (Locked Rotor Amp)</p> <p>Locked Rotor Amp value is the higher average current as measured on mechanically blocked compressors tested under nominal voltage. The</p>	<p>LRA value can be used as a rough estimation for the starting current. However, in most cases, the real starting current will be lower.</p>
	<p>MCC (Maximum Continuous Current)</p> <p>The MCC is the current at which the motor protection trips under maximum load and low voltage conditions. This MCC value is the maximum at which the compressor can be</p>	<p>operated in transient conditions and out of the application envelope. Above this value, the external electronic module will cut-out the compressor to protect the motor.</p>
	<p>Max. operating Current</p> <p>The max. operating current is the current when the compressors operate at maximum load conditions and 10% below nominal voltage. Max Oper. Current can be used to select cables and</p>	<p>contactors. In normal operation, the compressor current consumption is always less than the Max Oper. Current value.</p>
PRODUCT INFORMATION	<p>Winding resistance</p> <p>Winding resistance is the resistance between phases at 25°C (77°F) (resistance value +/- 7%). Winding resistance is generally low and it requires adapted tools for precise measurement. Use a digital ohm-meter, a "4 wires" method and measure under stabilised ambient temperature. Winding resistance varies strongly with winding temperature. If the compressor is stabilised at a different value than 25°C (77°F), the measured resistance must be corrected using the following formula:</p>	$R_{t_{amb}} = R_{25^{\circ}\text{C (77}^{\circ}\text{F)}} \frac{a + t_{amb}}{a + t_{25^{\circ}\text{C (77}^{\circ}\text{F)}}$ <p> $t_{25^{\circ}\text{C (77}^{\circ}\text{F)}$: reference temperature = 25°C (77°F) t_{amb} : temperature during measurement (°C) (°F) $R_{25^{\circ}\text{C (77}^{\circ}\text{F)}$: winding resistance at 25°C (77°F) R_{amb} : winding resistance at t_{amb} Coefficient $a = 234.5$ </p>
SYSTEM DESIGN	<p>Motor protection</p> <p>Danfoss Scroll Compressors DCJ series are equipped with an internal line break protector mounted on the motor windings. The protector is an automatic reset device, containing a snap action bimetal switch.</p> <p>Internal protectors respond to over-current and overheating. They are designed to interrupt.</p>	<p>When the motor temperature is too high, then the internal protector will trip.</p> <p>If the internal overload protector trips out, it must cool down to about 60°C (140°F) to reset. Depending on ambient temperature, this may take up to several hours.</p>
INTEGRATION INTO SYSTEM	<p>Phase sequence and reverse rotation protection</p> <p> The compressor will only operate properly in a single direction. Use a phase meter to establish the phase orders and connect line phases L1, L2 and L3 to terminals T1, T2 and T3, respectively. For three-phase compressors, the motor will run equally well in both directions. Reverse rotation results in excessive noise; no pressure differential between suction and discharge; and suction line warming rather than immediate cooling. A service technician should be present at initial start-up to verify that supply power is properly phased and that compressor and auxiliaries are rotating in the correct direction.</p> <p>Compressor models DCJ series incorporate an internal reverse vent valve which will react when</p>	<p>the compressor is run in reverse and will allow refrigerant to circulate through a by-pass from the suction to the discharge. Although reverse rotation is not destructive for these models, it should be corrected as soon as possible. Repeated reverse rotation over 24 hours may have negative impact on the bearings.</p> <p>Reverse rotation will be obvious to the user as soon as power is turned on: the compressor will not build up pressure, the sound level will be abnormally high and power consumption will be minimal. If reverse rotation symptoms occur, shut the compressor down and connect the phases to their proper terminals. If reverse rotation is not halted, the compressor will cycle off on the motor protection.</p>
ORDERING INFORMATION		

Approval and certificates

DCJ scroll compressors comply with the following approvals and certificates. Certificates are listed on www.commercialcompressors.danfoss.com/documentation/certificates/

CE (European Directive)		All models
UL (Underwriters Laboratories)		All models
Other approvals / certificates		Contact Danfoss

Low voltage directive 2014/35/EU

Products	DCJ091-106-121
Declaration of conformity ref. Low voltage Directive 2014/35/EU	Contact Danfoss

Machines directive 2006/42/EC

Products	DCJ091-106-121
Manufacturer's declaration of incorporation ref. Machines Directive 2006/42/EC	Contact Danfoss

Pressure equipment directive 2014/68/EU

Products	DCJ091-106-121
Refrigerant fluids	Group 2
Category PED	I
Evaluation module	No scope

Internal free volume

Products	Internal free volume at LP side without oil
DCJ091-106-121	5.75 litre (1.51 gallon)

GENERAL INFORMATION

PRODUCT INFORMATION

SYSTEM DESIGN

INTEGRATION INTO SYSTEM

ORDERING INFORMATION

General requirements

Proper piping practices should be employed to:

1. Ensure adequate oil return, even under minimum load conditions (refrigerant speed, piping slopes...). For validation tests see section "Manage oil in the circuit".

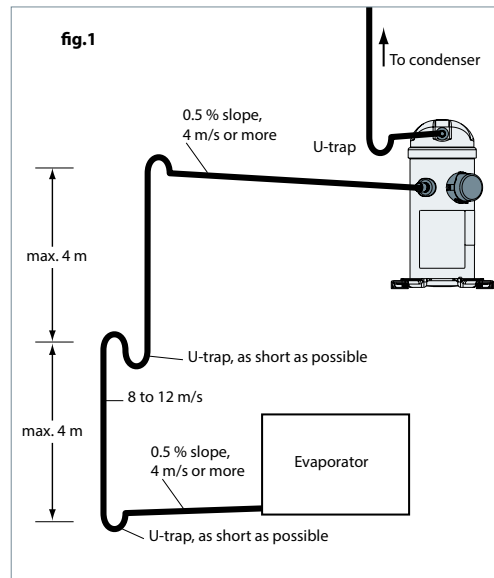

3. Piping should be designed with adequate three-dimensional flexibility to avoid excess vibration. It should not be in contact with the surrounding structure, unless a proper tubing

2. Avoid condensed liquid refrigerant from draining back to the compressor when stopped (discharge piping upper loop). For validation tests see section "Manage off cycle migration".

General recommendations are described in the figures below:

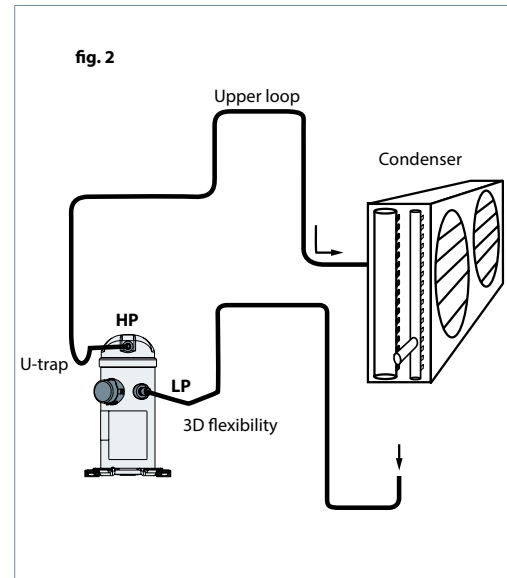

mount has been installed. For more information on noise and vibration, see section on: "MANAGE SOUND AND VIBRATION".

Design piping

Tandem requirements

DCJ tandem use static oil balancing principle to equalize oil level between the compressors by gravity. This is ensured by a precise suction and oil equalization piping designs.

The discharge line as no impact on oil balancing and is shown with tees, to indicate that both left and right side discharge header are possible

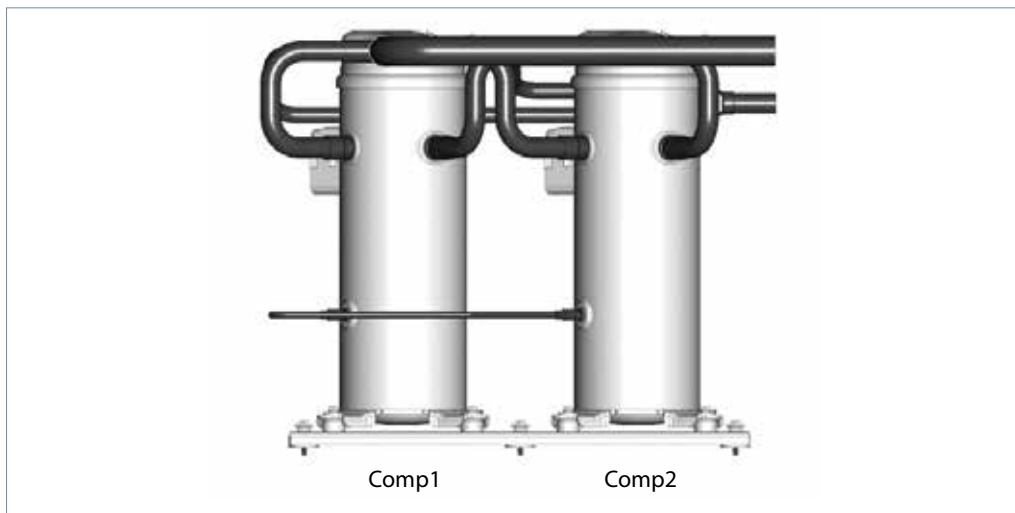

Danfoss DCJ scroll compressors in C8 version can be mounted in tandem assemblies.

Such manifolding applications require special design considerations that go beyond the scope of this document. Please contact Danfoss for further information.

For each tandem configuration, specific outline drawings are available as indicated in following tables.

R Suction and oil equalization piping drawing must be respected (diameters, minimum straight lengths...)

Tandem model	Comp.1	Comp.2	Suction (in)	Discharge (in)	Oil equalization (mm)	Gas equalization (mm)	Suction washer φ (MM)r	Washer in scution of	Kit tandem Code No	Outline drawing number
DCJ182	DCJ091	DCJ091	1-5/8"	1-1/8"	3/8"	1-1/8"	Not needed		120Z0636	8556178
DCJ212	DCJ106	DCJ106	1-5/8"	1-1/8"	3/8"	1-1/8"	Not needed		120Z0636	8556178
DCJ242	DCJ121	DCJ121	1-5/8"	1-1/8"	3/8"	1-1/8"	Not needed		120Z0636	8556178
DCJ211	DCJ121	DCJ091	1-5/8"	1-1/8"	3/8"	1-1/8"	5311983P01 (φ 19.5)	Comp 2	120Z0636	8556178
DCJ211	DCJ091	DCJ121	1-5/8"	1-1/8"	3/8"	1-1/8"	Not needed		120Z0636	8556178

* Left suction connection
** Right suction connection

R Depending on manifold configuration, it is essential to equalize the pressure of compressor sumps. Hence, a suction washer must be added

on certain compressors according to table. Suction washer is included in tandem accessory kit.

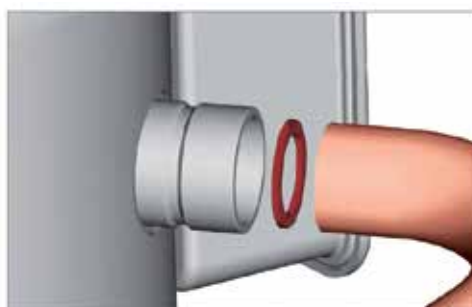

Red Included in tandem accessory kit
Orange Not supplied

Design compressor mounting

General requirements

Compressors used in single applications must be mounted with flexible grommets.

and the manifold assembly must be mounted with flexible grommets onto frame.

Compressors used in parallel application must be mounted with rigid mounting spacers onto rails

During operation, the maximum inclination from the vertical plane must not exceed 7 degrees.

Single requirements

Compressors DCJ come delivered with flexible grommets ,accessory Mounting kit 120Z5064

The grommets must be compressed until contact between the flat washer and the steel mounting sleeve is established. The required bolt size for the DCJ091-109-121 compressors is M8*40mm. This bolt must be tightened to a torque of 11 Nm (8ft.lbs).

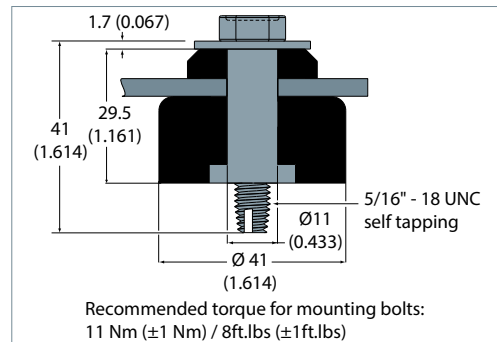

Tandem requirements

Parallel mounting feet

For parallel mounting, the compressor must be mounted with rigid mounting spacers(included in the tandem kit 120Z0636) on the rails.Rubber

grommets and sleeves (delivered with the compressor)must be installed below the rails.

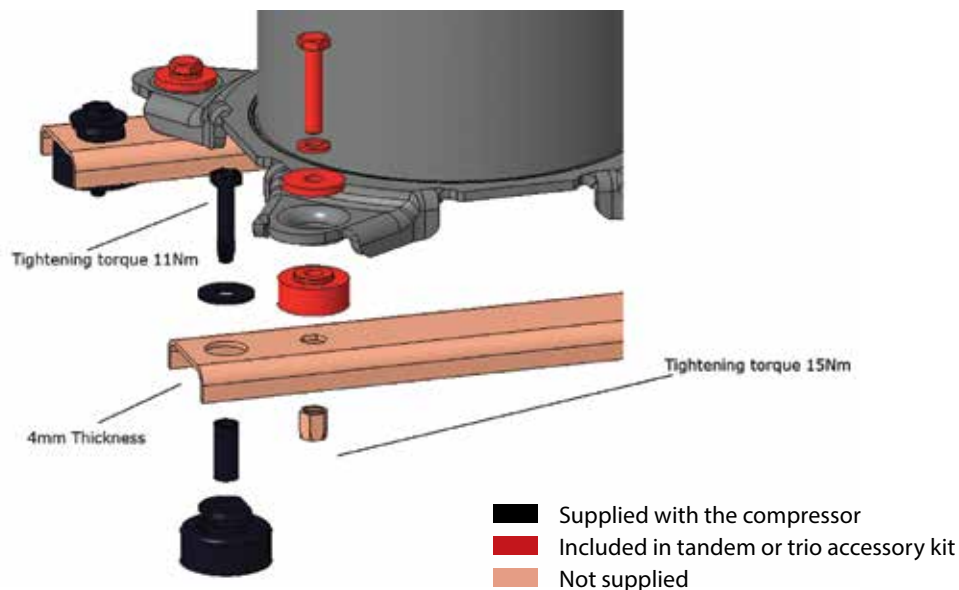

Compressor sound radiation

Typical sounds and vibrations in systems can be broken down into the following three categories:

- Sound radiation (through air)
- Mechanical vibrations (through parts and structure)

- Gas pulsation (through refrigerant)

The following sections focus on the causes and methods of mitigation for each of the above sources.

For sound radiating from the compressors, the emission path is air and the sound waves are travelling directly from the machine in all directions.

Sound levels are as follows:

- For compressors running alone:

Compressor model	50 Hz		60 Hz		Acoustic hood code number
	Sound power dB(A)	Attenuation dBA ①	Sound power dB(A)	Attenuation dBA ①	
DCJ091	75	6	78	5	120Z5085
DCJ106	75	6	78	5	120Z5085
DCJ121	75	6	78	5	120Z5085

Sound power and attenuation are given at ARI conditions, measured in free space
 ① Attenuation given with acoustic hood only

Acoustic hood could be applied for both single and tandem version compressors
 Materials are UL approved and RoHS compliant
 Maximum sound is +5dBA

- For compressors running simultaneously,
 • the global sound level of “n” identical compressors is:

$$L_{\text{GLOBAL}} = L_i + 10 \text{Log}_{10} n$$

Example for the tandem DCJ182 = 2 x DCJ091 (50Hz)

$$L_{\text{DCJ091}} = 75\text{dB(A)}$$

$$L_{\text{DCJ182}} = 75 + 10 \text{Log}_{10} 2 = 78\text{dB(A)}$$

	Model	Composition	50 Hz	60 Hz
Tandem	DCJ182	2xDCJ091	78	81
	DCJ212	2xDCJ106	78	81
	DCJ242	2xDCJ121	78	81
	DCJ211	DCJ091+DCJ121	78	81

Mitigations methods:

We can consider two means to reduce compressors sound radiations:

1. Acoustic hoods are quick and easy to install and do not increase the overall size of the compressors. Acoustic hoods are available from Danfoss as accessories. Refer to the table above for sound levels, attenuation and code numbers.
2. Use of sound-insulation materials on the inside of unit panels is also an effective means to reduce radiation.

Note: During compressor shut down, a short reverse rotation sound is generated. The duration of this sound depends on the pressure difference at shut down and should be less than 3 seconds. This phenomenon has no impact on compressor reliability.

Manage sound and vibration

GENERAL INFORMATION

Mechanical vibrations

Vibration isolation constitutes the primary method for controlling structural vibration. DCJ scroll compressors are designed to produce minimal vibration during operations. The use of rubber isolators on the compressor base plate or on the frame of a manifolded unit is very effective in reducing vibration being transmitted from the compressor(s) to the unit. Rubber grommets are supplied with all DCJ scroll compressors.

Once the supplied rubber grommets have been properly mounted, vibration transmitted from the compressor base plate to the unit

are held to a strict minimum. In addition, it is extremely important that the frame supporting the mounted compressor be of sufficient mass and stiffness to help dampen any residual vibration potentially transmitted to the frame. The tubing should be designed so as to both reduce the transmission of vibrations to other structures and withstand vibration without incurring any damage. Tubing should also be designed for three-dimensional flexibility. For more information on piping design, please see the section entitled "Essential piping design considerations".

PRODUCT INFORMATION

Gas pulsation

The Danfoss scroll compressor DCJ has been designed and tested to ensure that gas pulsation has been optimized for the most commonly encountered air conditioning pressure ratio. Manifolded compressors are equivalent to lagged sources of gas pulsation. Therefore pulse level can vary during time.

Mitigation methods:

If an unacceptable level is identified, a discharge muffler with the appropriate resonant volume and mass can be installed.

SYSTEM DESIGN

INTEGRATION INTO SYSTEM

ORDERING INFORMATION

Manage operating envelope

Requirement

R The operating envelope for DCJ scroll compressors is given in the figures below and guarantees reliable operations of the compressor for steady-state operation.

Steady-state operation envelope is valid for a suction superheat within 5K to 30K range at nominal voltage.

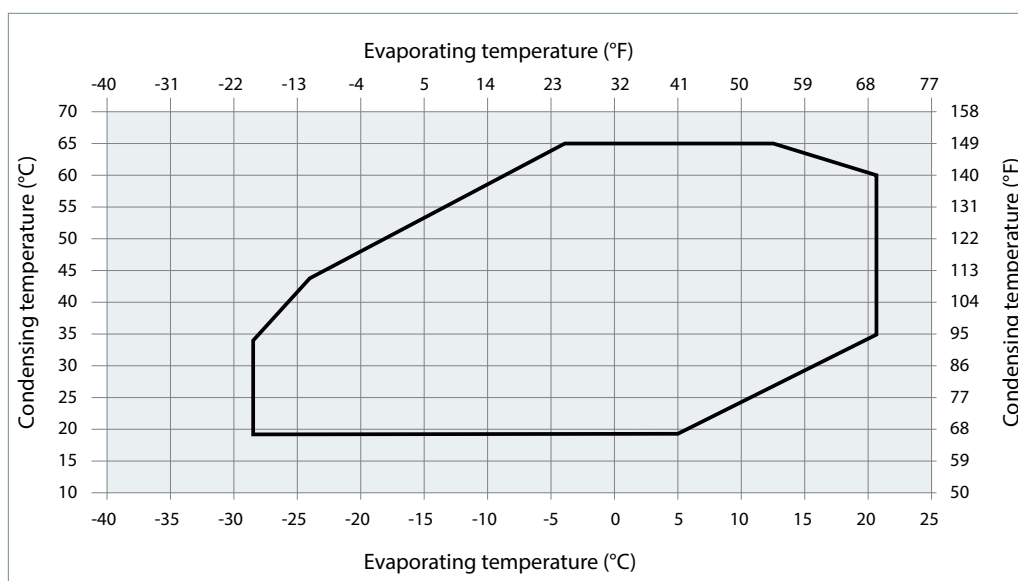

— DCJ with R410A Map (5K)

Pressure settings	R410A	
	bar(g)	psig
Working range high side	15.8-44.5	229.1-645.3
Working range low side	1.9-10.8	27.6-156.6
Maximum high pressure safety switch setting	45	652.5
Minimum low pressure safety switch setting	1.5	21.8
Minimum low pressure pump-down switch setting	2.5bar below nominal evap. pressure with minimum of 2.3bar(g)	36.3psig below nominal evap. pressure with minimum of 33.4 psig

R LP and HP safety switches must never be bypassed nor delayed and must stop all the compressors.

When caused low by LP safety switch, limit the number of auto-restart to maximum 5 times within 12 hours.

! HP safety switch must be manual reset

Depending on application operating envelope, you must define HP and LP limits within operating envelope and pressure setting table above.

For DCJ compressors, the external Discharge Gas Temperature protection (DGT) is required if the high and low pressure switch settings do not protect the compressor against operations beyond its specific application envelope.

The discharge gas thermostat accessory kit (code 7750009) includes all components required for installation as shown on the right. DGT installation must respect below requirements:

- The thermostat must be attached to the discharge line within 150 mm (5.91 inch) from the compressor discharge port and must be thermally insulated and tightly fixed on the pipe.
- The DGT should be set to open at a discharge gas temperature of 135°C (275°F).

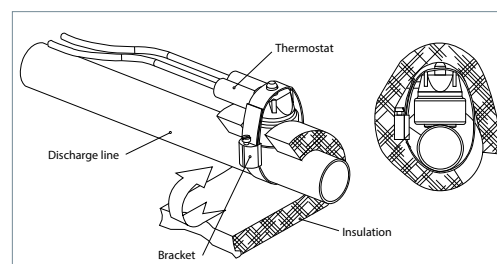

Manage operating envelope

Evaluate the risk

HP and LP must be monitored to respect operating envelope limitations. We consider two types of operating envelope management:

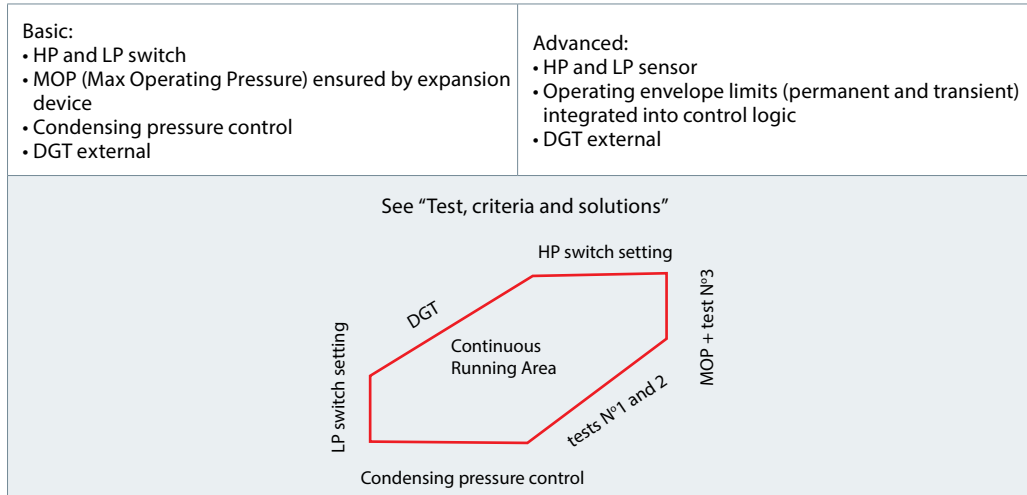

Test, criteria and solutions

Test N°	Purpose	Test condition	Pass criteria	Solutions
1	Check the compressor operation in the "continuous running area".	Start test at minimum foreseeable evaporating temperature (minimum ambient temperature...)	Confirmed compressor stable working in the continuous running area.	Work on compressor staging, fan staging, water flow etc...
2		Perform a defrost test if reversible unit		

Manage superheat

During normal operation, refrigerant enters the compressor as a superheated vapor. Liquid flood back occurs when a part of the refrigerant entering the compressor is still in liquid state.

Liquid flood back can cause oil dilution and, in extreme situations lead to liquid slugging that can damage compression parts.

Requirement

In steady state conditions,

- Suction superheat must remain within 5K to 30K (9°F to 54°F)
- According to the floodback chart

In transient conditions,

- According to the floodback chart

Discharge temperature sensor must be placed onto the discharge fitting and be insulated.

Oil temperature sensor must be placed on the mid shell, closed to the low shell, and be insulated.

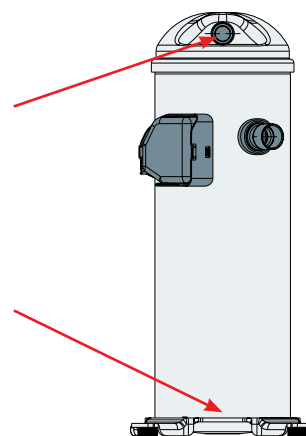

Evaluate the risk

Use the tables below in relation with the system charge and the application to quickly evaluate the risk and potential tests to perform.

	BELOW CHARGE LIMIT	ABOVE CHARGE LIMIT
Non reversible	No test or additional safeties required	Liquid flood back test
Reversible	Defrost test	Liquid flood back test Defrost test

Charge limit is defined in table below:

	Models	Composition	Refrigerant charge limit	
			(kg)	(lbs)
Single	DCJ091		7.2	16
	DCJ106		7.2	16
	DCJ121		7.2	16

Manage superheat

Test, criteria and solutions

Test N°	Purpose	Test condition	Pass criteria	Solutions
Liquid flood back test	Steady-state	 <p>Liquid flood back testing must be carried out under expansion valve threshold operating conditions:</p> <ul style="list-style-type: none"> • Lowest foreseeable evaporation, and highest foreseeable condensation. • Minimum number of compressor running. <p>For reversible system, perform test in both heating and cooling mode.</p>	Suction superheat >5K (9°F)	<ol style="list-style-type: none"> 1. Check expansion valve selection and setting. <ul style="list-style-type: none"> • For Thermostatic expansion valve (TXV) check bulb position... • For Electronic expansion valve (EXV) check measurement chain and PID.... 2. Add a suction accumulator*.
	Transient	<p>Tests must be carried out with most unfavorable conditions :</p> <ul style="list-style-type: none"> • fan staging, • compressor staging • ... 	Oil superheat shall not be more than 30 sec below the safe limit defined in the Dilution Chart. (see graph below)	
Defrost test	Check liquid floodback during defrost cycle	Defrost test must be carried out in the most unfavorable conditions (at 0°C (32°F) evaporating temperature).	Oil superheat shall not be more than 30 sec below the safe limit defined in the Dilution Chart. (see graph below)	<ol style="list-style-type: none"> 1. Check defrost logic. In reversible systems, the defrost logic can be worked out to limit liquid floodback effect. (for more details see "Control Logic"). 2. Add a suction accumulator*.

*Suction accumulator offers protection by trapping the liquid refrigerant upstream from the compressor. The accumulator should be sized at least 50 % of the total system charge. Suction accumulator dimensions can impact oil return (gas velocity, oil return hole size...), therefore oil return has to be checked according to section "Manage oil in the circuit".

Floodback Requirement

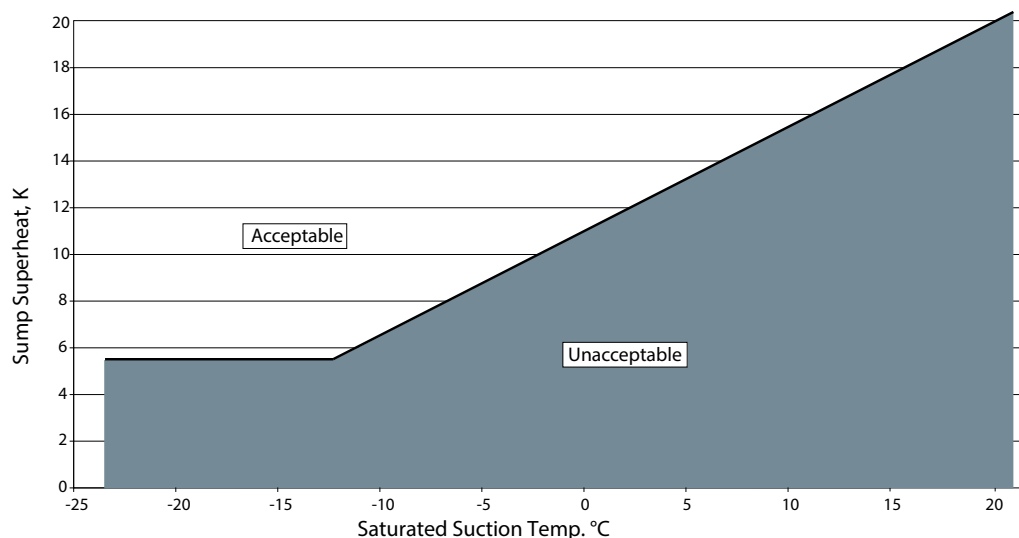

Manage off cycle migration

- R** Off-cycle refrigerant migration happens:
- when the compressor is located at the coldest part of the installation, refrigerant vapor condenses in the compressor.
 - or directly in liquid-phase by gravity or pressure difference..

When the compressor starts, the refrigerant diluted in the oil, or stored in evaporator, generates poor lubrication conditions, and may reduce bearings life time.. In extreme situations, this leads to liquid slugging that can damage compression scroll set.

Requirement

- Compressor can tolerate occasional flooded start, but it should remain exceptional situation and unit design must prevent that this situation happen at each start.

- Right after start, liquid refrigerant must not flow massively to compressor
- The charge limit is a threshold beyond some protective measures must be taken to limit risk of liquid slugging and extreme dilution at start.

Evaluate the risk

Use the table below in relation with the system charge (refer to charge limit table in section "Manage superheat") and the application to

quickly define necessary safeties to implement and test to perform:

	BELOW CHARGE LIMIT	ABOVE CHARGE LIMIT
All	Ensure tightness between condenser & evaporator when system is OFF • Thermostatic expansion Valve (TXV) , Liquid Line Solenoid Valve LLSV** strongly recommended • Electronic expansion valve (EXV) must close when system stop including in power shut down situation	
Non split	No test or additional safeties required	• Crank Case Heater * • Migration test • External Non Return Valve
Split	Since each installation is unique, no test can fully evaluate off-cycle migration, therefore the following safeties are required: • Crank Case Heater * • Liquid Line Solenoid Valve**+ pump-down cycle***	

Manage off cycle migration

GENERAL INFORMATION

Crank case heater

* Crank case heater (CCH)

The Crank case heaters are designed to protect the compressor against off-cycle migration of refrigerant. Additional heater power or thermal insulation might be needed in case of ambient temperature below -5°C (23°F) and a wind speed above 5m/second.

The heater must be energized whenever all the compressors are off.

Crank case heater accessories are available from Danfoss (see section "Accessories").

Provide separate electrical supply for the heaters so that they remain energized even when the machine is out of service (e.g. seasonal shutdown).

It's recommended that the heater be turned on for a minimum of 8 hours prior to starting the compressor.

**Liquid line solenoid valve (LLSV)

A LLSV is used to isolate the liquid charge on the condenser side, thereby preventing against charge transfer to the compressor during off -cycles. The quantity of refrigerant on the low-pressure side of the system can be further reduced by using a pump-down cycle in association with the LLSV.

***Pump-down cycle

By decreasing pressure in the sump, pump down:

- evacuates refrigerant from oil
- set the sump saturating pressure much lower than ambience temperature and due to that, avoid refrigerant condensation in the compressor.

For more details on pump-down cycle see section "Control Logic".

PRODUCT INFORMATION

On/off cycling (cycle rate limit)

Danfoss recommends a restart delay timer to limit compressor cycling. The timer prevents reverse compressor rotation, which may occur during brief power interruptions.

The system must be designed in a way that guarantees a minimum compressor running time of 2 minutes so as to provide for sufficient

motor cooling after start-up along with proper oil return. Note that the oil return may vary since it depends upon system design.

There must be no more than 12 starts per hour, a number higher than 12 reduces the service life of the motor-compressor unit. A three-minute (180-sec) time out is recommended.

SYSTEM DESIGN

INTEGRATION INTO SYSTEM

ORDERING INFORMATION

Provide power supply and electrical protection

Wiring information

Requirements:

- An additional external overload protection is still advisable for either alarm or manual reset. For overload setting, take the max current you can face on the application and add 10%. Setting must always be lower than Max Operating Current (see table "Three phase electrical characteristics" from the section "Electrical data, connections and wiring")

- HP safety switch and DGT must be wired in the safety chain. Other safety devices such as LP can be either hardware or software managed.
- Provide separate electrical supply for the heaters so that they remain energized even when the machine is out of service (e.g. seasonal shutdown).

The wiring diagrams below are examples for a safe and reliable compressor wiring:

Compressor model DCJ091-106-121

Control device.....	TH
Optional short cycle timer (3 min)	180 s
Control relay	KA
Liquid Line Solenoid valve.....	LLSV
Compressor contactor.....	KM
Phase monitor.....	PM
Safety lock out relay.....	KS
Pump-down control low pressure switch ..	LP
High pressure safety switch.....	HPs
Fused disconnect	Q1
Fuses	F1
Compressor motor	M
Discharge gas thermostat.....	DGT

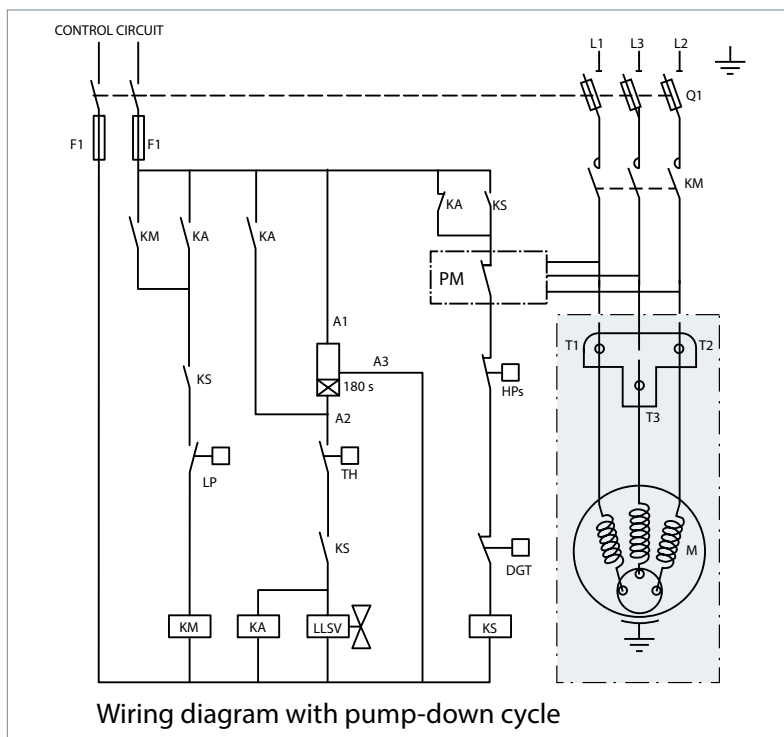

Note:

For DCJ phase monitors are mandatory. The selected phase monitor should lock out the compressor from operation in reverse.

Control logic

Safety control logic requirements

	Tripping conditions		Re-start conditions	
	Value	Time	Value	Time
HP switch	See Pressure settings table from section "Manage operating envelope"	Immediate, no delay. No by-pass	Conditions back to normal. Switch closed again	Manual reset
LP safety switch				Maximum 5 auto reset during a period of 12 hours, then manual reset.
Electronic module (Motor protection, DGT)				

Cycle rate limit requirements

Danfoss requires a minimum compressor running time of 2 minutes to ensure proper oil return and sufficient motor cooling. Additionally, compressor service life is based on a maximum of 12 starts per hour.

Therefore, to guarantee these 2 requirements, a three-minute (180- sec) time out is recommended.

Oil management logic recommendations

In some cases, oil management can be enhanced by control logic:

If oil return test failed, a function can be integrated in control to run all compressors simultaneously during one minute every hour in order to boost oil return. Time and delay can be fine-tuned by oil return test N°1 §Manage oil in the circuit. During oil boost, pay special attention

to superheat management to avoid liquid flood back and foaming.

If after running long time in full load, oil unbalance appears, then a function can be in control to stop all compressors in manifold during one minute every two hours in order to balance oil between compressors. Time and delay can be fine-tuned by Oil balancing test N°2 §Manage oil in the circuit.

GENERAL INFORMATION

PRODUCT INFORMATION

SYSTEM DESIGN

INTEGRATION INTO SYSTEM

ORDERING INFORMATION

Control logic

Defrost logic recommendations

In reversible systems, the defrost logic can be worked out to limit liquid flood back effect by:

1. Running full load during defrost to share liquid refrigerant between all compressors.

2. Transferring liquid refrigerant from one exchanger to the other one thanks to pressures.

The following defrost logic combines both advantages:

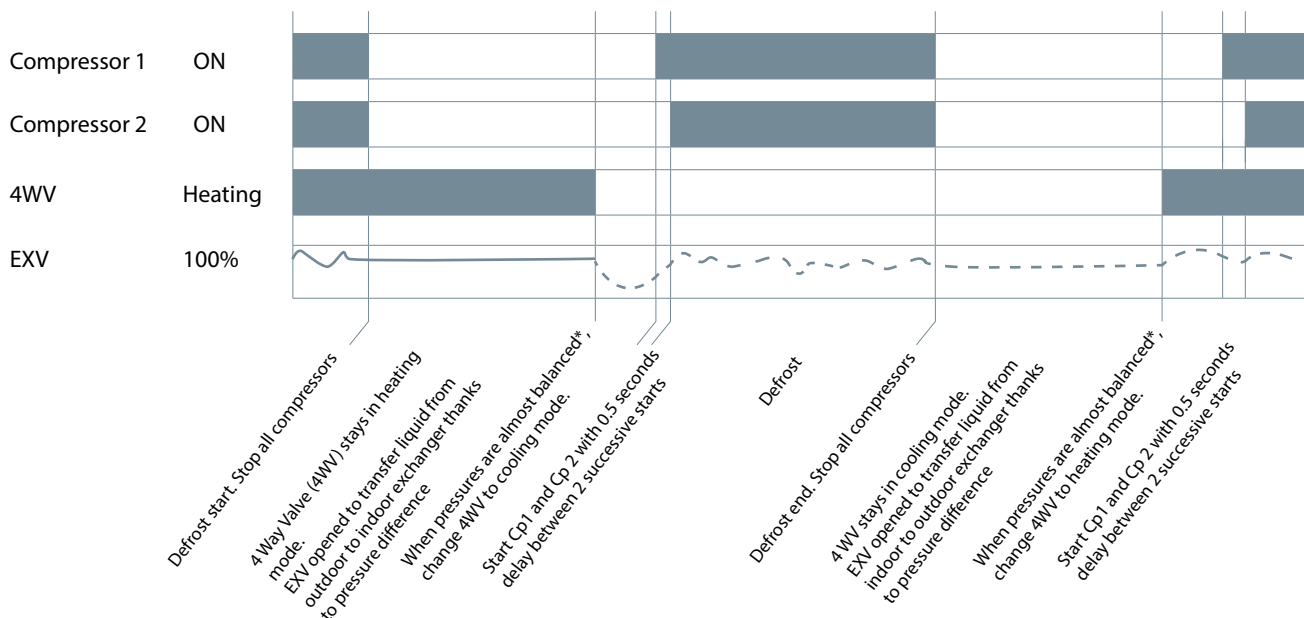

* EXV Opening degree and time have to be set to keep a minimum pressure for 4 way valve moving. In any case, defrost logics must respect requirements and tests described in sections "Manage superheat" and "Manage operating envelope".

Pump-down logic recommendations

Pump down is initiated prior to shutting down the last compressor on the circuit by de-energizing a liquid line solenoid valve or closing electronic expansion valve. When suction pressure reached the cut-out pressure, compressor is stopped, and liquid solenoid valve or electronic expansion valve remains closed.

Two types of pump-down exist:

- One shot pump down (preferred): when

last compressor of the circuit stops, suction pressure is decreased 2.5 bar (36 psi) below nominal evaporating pressure. Even if suction pressure increases again, the compressor will not restart.

- Continuous pump-down: traditional pump-down, Compressor restarts automatically when suction pressure increases. A non-return valve in the discharge line is recommended.

Reduce moisture in the system

GENERAL INFORMATION	<p>Excessive air and moisture</p> <ul style="list-style-type: none"> • can increase condensing pressure and cause excessively high discharge temperatures. • can create acid giving rise to copper plating. 	<ul style="list-style-type: none"> • can destroy the lubricating properties of the oil. <p>All these phenomena can reduce service life and cause mechanical and electrical compressor failure.</p>
Requirements	<p>DCJ compressors are delivered with < 100 ppm moisture level.</p> <p>At the time of commissioning, system moisture content may be up to 100 ppm.</p>	<p>During operation, the filter drier must reduce this to a level between 20 and 50 ppm.</p>
PRODUCT INFORMATION	<p>Solutions</p> <p>To achieve this requirement, a properly sized and type of drier is required. Important selection criteria's include:</p> <ul style="list-style-type: none"> • driers water content capacity, • system refrigeration capacity, • system refrigerant charge. 	<p>For new installations with DCJ compressors with polyolester oil, Danfoss recommends using the Danfoss DML (100% molecular sieve) solid core filter drier.</p>
SYSTEM DESIGN		
INTEGRATION INTO SYSTEM		
ORDERING INFORMATION		

Assembly line procedure

Compressor storage

Store the compressor not exposed to rain, corrosive or flammable atmosphere between -35°C (-31°F) and 70°C (158°F) when charged with

nitrogen and between -35°C (-31°F) and 52°C (127.4°F) when charged with R410A refrigerant.

Compressor holding charge

Each compressor is shipped with a nominal dry nitrogen holding charge between 0.3 bar (4 psi) and 0.7 bar (10 psi) and is sealed with elastomer plugs.



Respect the following sequence:

- Remove the nitrogen holding charge via the suction Schrader valve to avoid an oil mist blow out.

- Remove the suction plug first and the discharge plug afterwards to avoid discharge check valve gets stuck in open position.

An opened compressor must not be exposed to air for more than 20 minutes to avoid moisture is captured by the PVE oil.

Handling



Each Danfoss scroll compressor DCJ is equipped with the lift ring on the top shell and ring for the discharge port.

- Always use both these rings when lifting the compressor.
- Use lifting equipment rated and certified for the weight of the compressor or compressor assembly.
- A spreader bar rated for the weight of the compressor is highly recommended to ensure a better load distribution.

- The use of lifting hooks closed with a clasp is recommended.
- For tandem and trio assemblies, use a spreader bar and all compressor rings as shown in picture below.
- Never use the lift rings on the compressor to lift the full unit.

Maintain the compressor in an upright position during all handling manoeuvres (maximum of 15° from vertical).

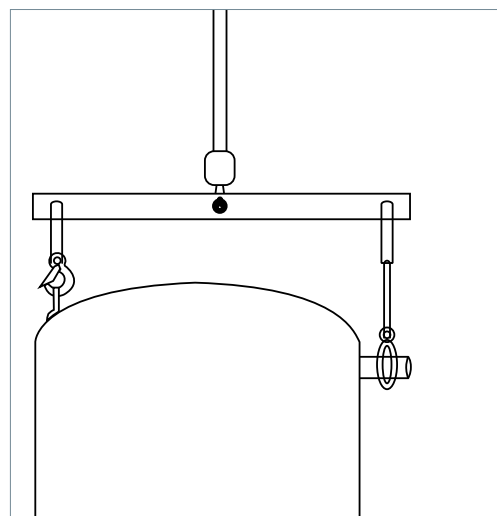

Piping assembly

Good practices for piping assembly is a pre-requisite to ensure compressor service life (system cleanliness, brazing procedure...)

System cleanliness

Circuit contamination possible cause:	Requirement:
Brazing and welding oxides	During brazing, flow nitrogen through the system
Filings and particles from the removal of burrs in pipe-work	Remove any particles and burrs generated by tube cutting and hole drilling
Moisture and air	Use only clean and dehydrated refrigeration grade copper tubing Opened compressor must not be exposed to air more than 20 minutes to avoid moisture captured by POE oil.

Brazing procedure:

- Brazing operations must be performed by qualified personnel.
- Make sure that no electrical wiring is connected to the compressor.
- To prevent compressor shell and electrical box overheating, use a heat shield and/or a heat-absorbent compound.
- Clean up connections with degreasing agent
- Flow nitrogen through the compressor.

- Use flux in paste or flux coated brazing rod.
- Use brazing rod with a minimum of 5% silver content.
- It is recommended to use double-tipped torch using acetylene to ensure a uniform heating of connection.
- To enhance the resistance to rust, a varnish on the connection is recommended.

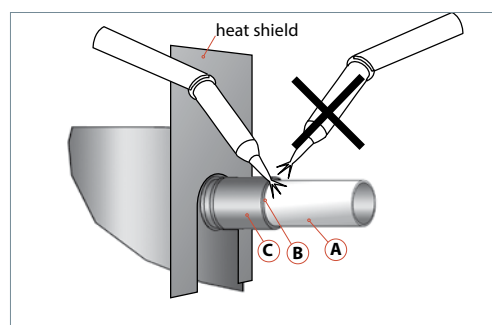

! Before eventual un-brazing of the compressor or any system component, the refrigerant charge must be removed.

System pressure test and leak detection

! The compressor has been strength tested and leak proof tested (<3g/year) at the factory. For system tests:

- Always use an inert gas such as Nitrogen or Helium.

- Pressurize the system on HP side first then LP side.
- Do not exceed the following pressures:

Maximum compressor test pressures	
Maximum compressor test pressure high side (HP)	45 bar (g) / 653 psi Do keep the low side pressure not exceed 31.1bar(g) / 451 psi
Maximum compressor test pressure low side (LP)	31.1 bar (g) / 451 psi

Assembly line procedure

Vacuum evacuation and moisture removal

Requirements:

- Never use the compressor to evacuate the system.
- Connect a vacuum pump to both the LP and HP sides.
- Evacuate the system to a pressure of 500 $\mu\text{m Hg}$ (0.67 mbar /9.7 mpsi) absolute.

Recommendations:

- Energized heaters improve moisture removal.
- Alternate vacuum phases and break vacuum with Nitrogen to improve moisture removal.

For more detailed information see "Vacuum pump-down and dehydration procedure" TI-026-0302.

Refrigerant charging



Initial charge:

- For the initial charge, the compressor must not run.
- Charge refrigerant as close as possible to the nominal system charge.
- This initial charging operation must be done in liquid phase between the condenser outlet and the filter drier.

If needed, a complement of charge can be done:

- In liquid phase while compressor is running by slowly throttling liquid in.
- On the low pressure side, as far away as possible from the compressor suction connection.
- Never bypass safety low pressure switch.

For more detailed information see "Recommended refrigerant system charging practice" FRCC.EN.050.

Dielectric strength and insulation resistance tests

The tests are performed on each compressor at the factory between each phase and ground.

- Dielectric strength test is done with a high potential voltage (hi-pot) of $2U_n + 1000\text{V AC}$ at least, and leakage current must be less than 5 mA. Additional tests of this type are not recommended as it may reduce motor lifetime. Nevertheless, if such a test is necessary, it must be performed at a lower voltage.

- Insulation resistance is measured with a 500 V DC megohm tester and must be higher than 1 megohm.

- The presence of refrigerant around the motor windings will result in lower resistance values to ground and higher leakage current readings. Such readings do not indicate a faulty compressor. To prevent this, the system can be first operated briefly to distribute refrigerant.



Do not use a megohm meter nor apply power to the compressor while it is under vacuum as this may cause internal damage.

Commissioning

GENERAL INFORMATION	<p>Preliminary check</p> <p> Check electrical power supply:</p> <ul style="list-style-type: none"> • Phase order: For DCJ compressors equipped with an electronic module, reverse rotation will be automatically detected. For more details refer to section "Motor protection". 	<ul style="list-style-type: none"> • Voltage and voltage unbalance within tolerance: For more details refer to section "Motor voltage".
PRODUCT INFORMATION	<p>Initial start-up</p> <ul style="list-style-type: none"> • Crankcase heaters must be energized at least 8 hours in advance to remove refrigerant. • A quicker start-up is possible by "jogging" the compressor to evacuate refrigerant. Start the 	<p>compressor for 1 second, then wait for 1 to 2 minutes. After 3 or 4 jogs the compressor can be started. This operation must be repeated for each compressor individually.</p>
SYSTEM DESIGN	<p>System monitoring</p> <p>The system must be monitored after initial startup for a minimum of 60 minutes to ensure proper operating characteristics such as:</p> <ul style="list-style-type: none"> • Correct superheat and subcooling. • Current draw of individual compressors within acceptable values (max operating current). • No abnormal vibrations and noise. • Correct oil level. 	<p>If Oil Top-up is needed, it must be done while the compressor is idle. Use the schrader connector or any other accessible connector on the compressor suction line. Always use original Danfoss PVE oil FVC68D(320HV) from new cans. For more detailed information see "Lubricants filling in instructions for Danfoss Commercial Compressors" TI 2-025-0402.</p>
INTEGRATION INTO SYSTEM	<p>Oil level checking and top-up</p> <p>In installations with good oil return and line runs up to 50 ft, no additional oil is required. If installation lines exceed 50 ft, additional oil may be needed. 1 or 2% of the total system refrigerant charge (in weight) can be used to roughly define the required oil top-up quantity.</p>	<p>Always use oil from new cans. Top-up the oil while the compressor is idle. Use any accessible connector on the compressor suction line and a suitable pump.</p>
ORDERING INFORMATION		

Dismantle and disposal



Danfoss recommends that compressors and compressor oil should be recycled by a suitable company at its site.

GENERAL INFORMATION

PRODUCT INFORMATION

SYSTEM DESIGN

INTEGRATION INTO SYSTEM

ORDERING INFORMATION

Packaging

Single pack

Compressors are packed individually in a cardboard box. They can be ordered in any quantity. Minimum ordering quantity = 1.

As far as possible, Danfoss will ship the boxes on full pallets of 9 compressors according below table.

Each box also contains following accessories:

- 4 grommets
- 4 assemblies of self tapping US thread bolts, washers and sleeves
- 4 additional sleeves
- 1 screw for earth connection

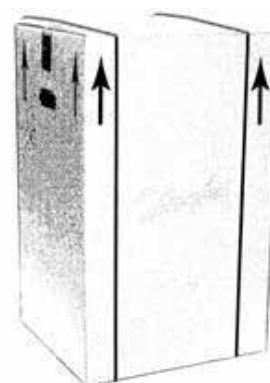

Industrial pack

Compressors are not packed individually but are shipped all together on one pallet. They can be ordered in quantities of full pallets only,

multiples of 12 compressors, according below table.

Each industrial pack pallet contains following accessories:

- 4 grommets per compressor
- 4 sleeves per compressor

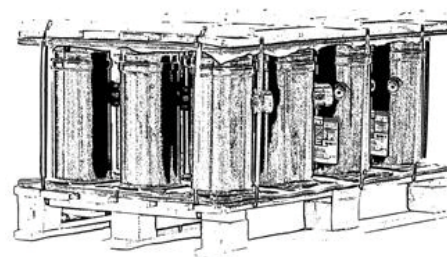

Ordering codes

Compressor code numbers

Danfoss scroll compressors DCJ can be ordered in either industrial packs or in single packs. Please use the code numbers from below tables for ordering.

Single pack

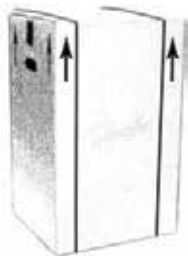

Compressor model	Length (mm)	Width (mm)	Height (mm)	Gross weight (kg)
DCJ091	1170	815	775	423
DCJ106	1170	815	775	423
DCJ121	1170	815	775	423

Compressor model	Model Variation	Connections	Feature	Code no.			
				2	4	7	9
				200-220/3/50 208-230/3/60	380-415/3/50 460/3/60	575/3/50	380/3/60
DCJ091	T	C	6	121L5003	121L5001	121L5005 **	121L5007 **
	T	C	8*	121L5029	121L5027	121L5031 **	121L5033 **
DCJ106	T	C	6	121L5011	121L5009	121L5013 **	121L5015 **
	T	C	8*	121L5037	121L5035	121L5039 **	121L5041 **
DCJ121	T	C	6	121L5019	121L5017	121L5021 **	121L5023 **
	T	C	8*	121L5045	121L5043	121L5047 **	121L5049 **

* Feature 8 is for tandem manifolding

** These code are preliminary.

Industrial pack

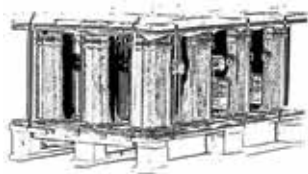

Compressor model	Nbr*	Length (mm)	Width (mm)	Height (mm)	Gross weight (kg)	Static stacking pallets
DCJ091	12	1170	815	723	622	4
DCJ106	12	1170	815	723	622	4
DCJ121	12	1170	815	723	622	4

Compressor model	Model Variation	Connections	Feature	Code no.			
				2	4	7	9
				200-220/3/50 208-230/3/60	380-415/3/50 460/3/60	575/3/50	380/3/60
DCJ091	T	C	6	121L5002	121L5000	121L5004 **	121L5006 **
	T	C	8*	121L5028	121L5026	121L5030 **	121L5032 **
DCJ106	T	C	6	121L5010	121L5008	121L5012 **	121L5014 **
	T	C	8*	121L5036	121L5034	121L5038 **	121L5040 **
DCJ121	T	C	6	121L5018	121L5016	121L5020 **	121L5022 **
	T	C	8*	121L5044	121L5042	121L5046 **	121L5048 **

* Feature 8 is for tandem manifolding

** These code are preliminary.

Ordering codes

Tandem code numbers

To build a complete tandem, you must order the 2 compressors and the Tandem kit code below

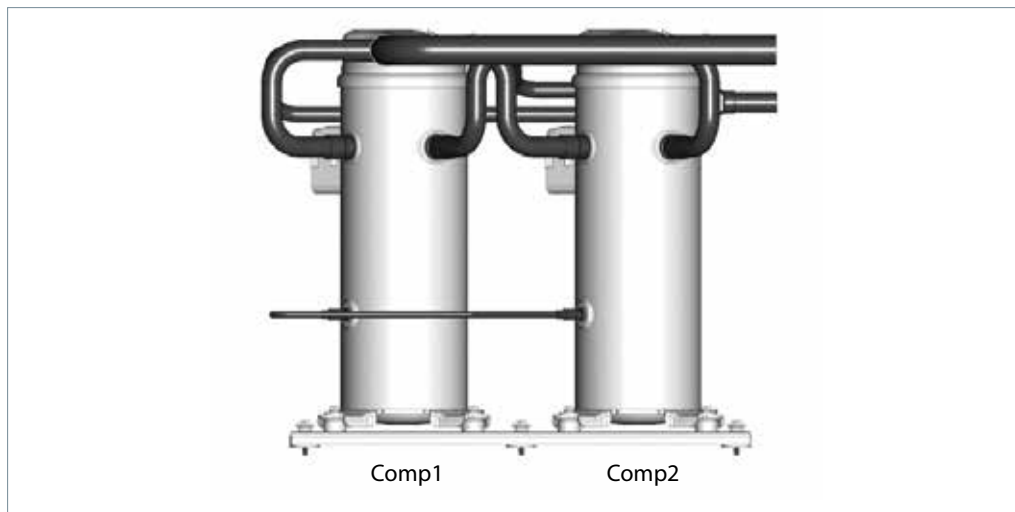

Except the configuration DCJ091(Comp 1)+DCJ121(Comp 2), all other configurations do not use the suction washer in tandem kit(120Z0636)



CP1	CP2	Tandem model	Suction from	Kit code n° to order
DCJ091	DC091	DCJ182	No Need	120Z0636
DCJ106	DCJ106	DCJ212	No Need	120Z0636
DCJ121	DCJ121	DCJ242	No Need	120Z0636
DCJ121	DCJ091	DCJ211	Washer in Comp 2	120Z0636
DCJ091	DCJ121	DCJ211	No Need	120Z0636

Accessories

Solder sleeve adapter set

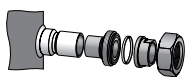

Code n°	Description	Application	Packaging	Pack size
120Z0129	Rotolock adaptor set (1-3/4" ~ 1-1/8"), (1-1/4" ~ 7/8")	DCJ091-121	Multipack	6

Rotolock adapter



Code n°	Description	Application	Packaging	Pack size
120Z0364	Adaptor (1"3/4 Rotolock - 1"1/8 ODS)	Models with 1"1/8 ODF	Multipack	10
120Z0367	Adaptor (1"1/4 Rotolock - 7/8» ODS)	Models with 7/8" ODF	Multipack	10

Crankcase heater



Code n°	Description	Application	Packaging	Pack size
120Z0059	Belt type crankcase heater, 65 W, 230 V, UL, CE mark	DCJ091-121	Multipack	6
120Z5011	Belt type crankcase heater, 70 W, 230 V, UL, CE mark	DCJ091-121	Multipack	6
120Z0060	Belt type crankcase heater, 65 W, 400 V, UL, CE mark	DCJ091-121	Multipack	6
120Z5012	Belt type crankcase heater, 70 W, 460 V, UL, CE mark	DCJ091-121	Multipack	6
120Z5013	Belt type crankcase heater, 70 W, 575 V, UL, CE mark	DCJ091-121	Multipack	6

Discharge temperature protection



Code n°	Description	Application	Packaging	Pack size
7750009	Discharge thermostat kit	All models	Multipack	10
7973008	Discharge thermostat kit	All models	Industry pack	50

Lubricant



Code n°	Description	Application	Packaging	Pack size
120Z5034	PVE(0.95 liter can) 320HV (FVC68D)	DCJ091-121	Multipack	1

Mounting hardware



Code n°	Description	Application	Packaging	Pack size
120Z5017	Mounting grommet	DCJ091-121	Single Pack	1
120Z5014	Mounting sleeve	DCJ091-121	Single Pack	1
120Z5031	Mounting kit, including 1 bolt, 1 sleeve, 1 washer	DCJ091-121	Single Pack	1
120Z5064	Mounting kit for 1 scroll compressor including 4 grommets, 4 sleeves, 4 bolts, 4 washers	DCJ091-121	Single Pack	1

Accessories

Acoustic hoods



Code n°	Description	Application	Packaging	Pack size
120Z5085	Acoustic hood for scroll compressor	DCJ091-121	Single pack	1

Terminal box



Code n°	Description	Application	Packaging	Pack size
120Z5018	Square terminal box (C & Q version)	C and Q version	Multipack	10

IP54 upgrade kit



Code n°	Description	Application	Packaging	Pack size
118U0057	IP54 upgrade kit	DCJ091-121	Multipack	6

Tandem kits



Code n°	Description	Application	Packaging	Pack size
120Z0636	Mounting kits for 2 compressors with 8 rigid spacers, 8 flat washers, 8 bolts, 8 locked washers, 1 suction washer.	DCJ 091,106.121	Single pack	1

Previous Version

- Page 6: Nomenclature
- Page 7: 50-60 Hz data
- Page 12: LRA, Motor protection, Phase sequence and reverse rotation protection
- Page 17: General requirements
- Page 22: Test, criteria and solutions - Manage superheat
- Page 23: Manage off cycle migration

Current Version

- Added US units for all data
- Page 6: Updated Nomenclature
- Page 7: Updated 50-60 Hz data
- Page 12: Updated LRA, Motor protection, Phase sequence and reverse rotation protection
- Page 17: Updated General requirements
- Page 22: Updated Test, criteria and solutions - Manage superheat
- Page 23: Updated Manage off cycle migration

Danfoss Commercial Compressors

is a worldwide manufacturer of compressors and condensing units for refrigeration and HVAC applications. With a wide range of high quality and innovative products we help your company to find the best possible energy efficient solution that respects the environment and reduces total life cycle costs.

We have 40 years of experience within the development of hermetic compressors which has brought us amongst the global leaders in our business, and positioned us as distinct variable speed technology specialists. Today we operate from engineering and manufacturing facilities spanning across three continents.



Danfoss Scrolls



Danfoss Inverter Scrolls



Danfoss Turbocor Compressors



Danfoss Light Commercial Refrigeration Compressors



Danfoss Maneurop Reciprocating Compressors



Danfoss Optyma Condensing Units

Our products can be found in a variety of applications such as rooftops, chillers, residential air conditioners, heatpumps, coldrooms, supermarkets, milk tank cooling and industrial cooling processes.

<http://cc.danfoss.com>

Danfoss Commercial Compressors, BP 331, 01603 Trévoux Cedex, France | +334 74 00 28 29



Danfoss can accept no responsibility for possible errors in catalogues, brochures and other printed material. Danfoss reserves the right to alter its products without notice. This also applies to products already on order provided that such alterations can be made without subsequential changes being necessary in specifications already agreed. All trademarks in this material are property of the respective companies. Danfoss and the Danfoss logotype are trademarks of Danfoss A/S. All rights reserved.