



Design Guide

VLT® Soft Starter - MCD 100

Contents

1.1.1 Introduction	2
1.2 Technical Data	3
1.3.1 Functional Diagram	4
1.3.4 Wiring	5
1.3.5 Adjustments	5
1.3.7 Dimensions	6
1.3.8 Operating at High Temperatures	7
1.3.10 Mounting Instructions	7
1.4 Application Examples	8

1

1.1.1 Introduction

The MCD 100 soft starters are designed for soft starting and stopping of 3 phase a.c. motors, thus reducing the inrush current and eliminating the damaging effects of high starting torque surges.

The digitally controlled soft starter features accurate settings and easy installation. The controller has individually adjustable acceleration and deceleration times.

Thanks to the adjustable initial torque and the unique breakaway (kick start) function the soft starter can be optimized for almost any application.

The MCD 100 soft starters are typically used on motor applications where a smooth start and/or stop is advantageous, such as conveyors, fans, pumps, compressors and high inertia loads. MCD 100 soft starters are also obvious as replacement for star/delta starters.

1.1.2 Features

- Motor load max. 25 A
- Acceleration times adjustable: 0-10 seconds
- Deceleration times adjustable: 0-10 seconds
- Initial torque adjustable up to 85%
- Breakaway function (kick start)

1.1.4 Selection Guide

Type	Max. power	Max. FLC	Voltage	DD order code
MCD 100-001	0,75 kW	3 A	208 - 240 V	175G4000
MCD 100-001	1,5 kW	3 A	400 - 415 V	175G4001
MCD 100-001	1,5 kW	3 A	440 - 480 V	175G4002
MCD 100-001	2,2 kW	3 A	550 - 600 V	175G4003
MCD 100-007	4 kW	15 A	208 - 240 V	175G4004
MCD 100-007	7,5 kW	15 A	400 - 480 V	175G4005
MCD 100-007	7,5 kW	15 A	500 - 600 V	175G4006
MCD 100-011	7,5 kW	25 A	208 - 240 V	175G4007
MCD 100-011	11 kW	25 A	400 - 480 V	175G4008
MCD 100-011	15 kW	25 A	500 - 600 V	175G4009

Table 1.1

- Universal control voltage: 24 - 480 V AC / DC
- Automatic detection of missing phases
- Automatic adaptation to 50/60 Hz
- LED Status indication
- Unlimited start/stop operations per hour (15A & 25A)
- Built in varistor protection
- Compact modular design
- DIN rail mountable
- CE (EN 60947-4-2)
- cULus (UL 508)

1.1.3 Adjustments

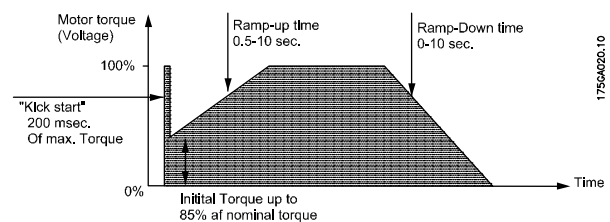

Illustration 1.1

1.2 Technical Data

Output specifications	MCD 100 - 001	MCD 100 - 007	MCD 100 - 011
Operational current max.	3A	15A	25A
Motor size at:			
208 - 240 V AC	0.1-0.75 kW (0.18-1 HP)	0.1-4.0 kW (0.18-5.5 HP)	0.1-7.5 kW (0.18-10 HP)
400 - 480 V AC	0.1-1.5 kW (0.18-2 HP)	0.1-7.5 kW (0.18-10 HP)	0.1-11 kW (0.18-15 HP)
550 - 600 V AC	0.1-2.2 kW (0.18-3 HP)	0.1-7.5 kW (0.18-10 HP)	0.1-15 kW (0.18-20 HP)
Leakage current max.	5 mA		
Min. operational current	50 mA		
Ratings:			
AC-53a Asynchronous motors	-	15A : AC-53a : 8-3 : 100 - 3000	25A : AC-53a : 8-3 : 100-3000
AC-53b Asynchronous motors with bypass	3A : AC-53b : 4-10 : 110	-	-
AC-58a Hermetic refrigeration compressors	-	15A : AC-58a : 6-6 : 100 - 3000	25A : AC-58a : 6-6 : 100-3000

Table 1.2

Control Circuit Specifications	
Control voltage range, 230 V	24-230 V
Control voltage range, 400-600 V	24 - 480 V AC / DC
Pick-Up voltage max.	20.4 V AC / DC
Drop-out voltage min.	5 V AC / DC
Max. control current for no operation	1 mA
Control current / Power max.	15 mA / 2 VA
Response time max.	70 ms
Ramp-up time	Adjust. from 0-10 sec.
Ramp-down time	Adjust. from 0-10 sec.
Initial torque	Adjust from 0-85% of nominal torque with optional, Kick start.
EMC immunity and emission	Meets requirements of EN 60947-4-2

Table 1.3

Insulation	
Rated insulation Voltage, U_i	660 V AC
Rated impulse withstand Voltage, U_{imp}	4 kV
Installation Category	III

Table 1.4

Thermal Specifications	MCD 100 - 001	MCD 100 - 007	MCD 100 - 011
Power dissipation continuous duty max.:	4W	2W/A	
Power dissipation intermittent duty max.:	4W	2W/A x Duty cycle	
Ambient temperature range	-5° C to 40°C		
Cooling method	Natural convection		
Mounting	Vertical +/- 30°		
Max. ambient temperature with limited rating	60°C, see derating for high temperatures in paragraph <i>Operating at High Temperatures</i> .		
Storage temp. range	-20°C to 80°C		
Protection degree/pollution degree	IP 20 / 3		

Table 1.5

Materials	
Housing	Self extinguishing PPO UL94V1
Heatsink	Aluminium black anodized
Base	Electroplated steel

Table 1.6

1.3.1 Functional Diagram

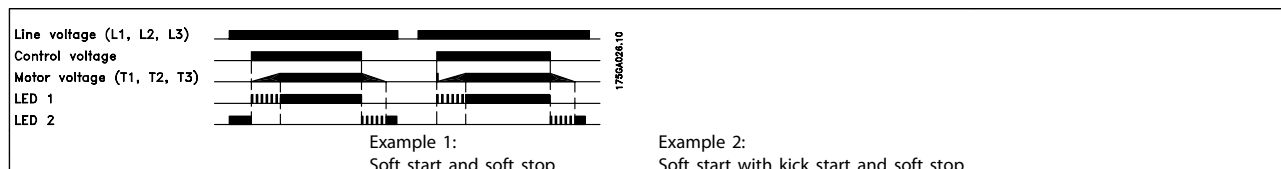

Table 1.7

1.3.2 Functional Description

Ramp up

During ramp-up the controller will gradually increase the voltage to the motor until it reaches full line voltage. The motor speed will depend on the actual load on the motor shaft. A motor with little or no load will reach full speed before the voltage has reached its maximum value. The actual ramp time is digitally calculated and will not be influenced by other settings, net frequency or load variations.

Initial torque

The initial torque is used to set the initial starting voltage. This way it is possible to adapt the controller to an

application requiring a higher starting torque. In some cases the application will need a high break-away torque. Here, the initial starting torque level can be combined with a kick start function. The kick start is a period of 200 ms where the motor receives full voltage.

Soft stop

During ramp-down the controller will gradually reduce the voltage to the motor thus reducing the torque and current. As a consequence the motor speed will fade off. The soft stop feature is advantageous to avoid liquid hammering and cavitation on pumps, and to avoid goods tilting on conveyors.

1.3.3 LED Status Indication

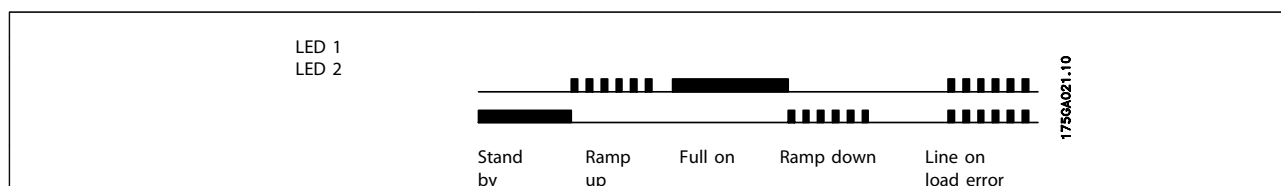

Table 1.8

1.3.4 Wiring

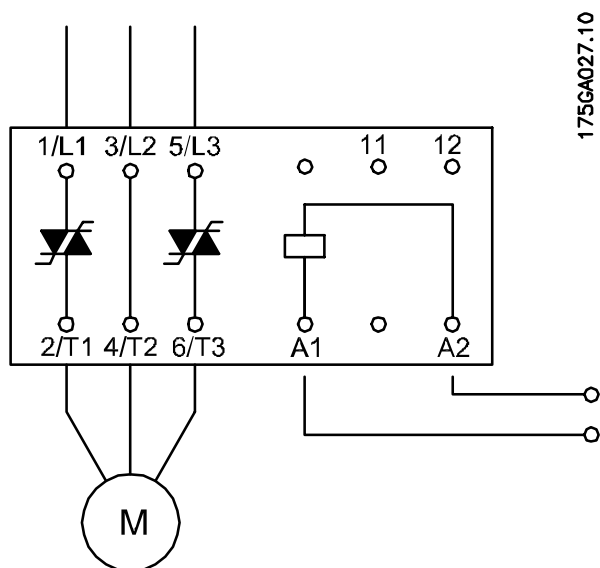

Illustration 1.2 MCD 100 - 007 / MCD 100 - 011

1.3.5 Adjustments

MCD 100 provides Timed Voltage Ramp up. This means that the motor voltage is gradually ramped up to full line voltage according to the time set by the rotary switch.

To avoid soft starter damage, proper settings of initial torque level and ramp up time must be considered. It is important to ensure that the motor is accelerated to full speed before the soft starter is in full on mode.

Setting the initial torque level:

1. Set ramp up time to max.
2. Set initial torque switch to min.
3. Apply control signal for a few seconds. If the motor does not rotate immediately increase the initial torque level with on step and try again. Repeat until the motor starts to rotate immediately after control signal is applied.

Setting the ramp up time:

1. Set ramp up time to max.
2. Decrease the ramp up time until mechanical surge is observed.
3. Increase ramp up time with one step.

1.3.6 Fuses and short circuit protection

In case of short circuits normal fuses can be used to protect the installation – but not the soft starter. The following table lists data for the selection of normal fuses.

MCD 100-001	Protection max 25 A gL/gG
MCD 100-007	Protection max 50 A gL/gG
MCD 100-011	Protection max 80 A gL/gG

Table 1.9

Semiconductor fuses may be used with MCD 100 soft start controllers. Use of semiconductor fuses will protect the SCR's in case of short circuits and reduce the potential of SCR damage due to transient overload currents. When selecting semiconductor fuses ensure that the fuse has a lower total clearing I^2t rating than the SCR (see data in the following table), and that the fuse can carry the start current for the actual start duration.

MCD 100	SCR I^2t (A ² s)
MCD 100-001	72
MCD 100-007	1800
MCD 100-011	6300

Table 1.10

1.3.7 Dimensions

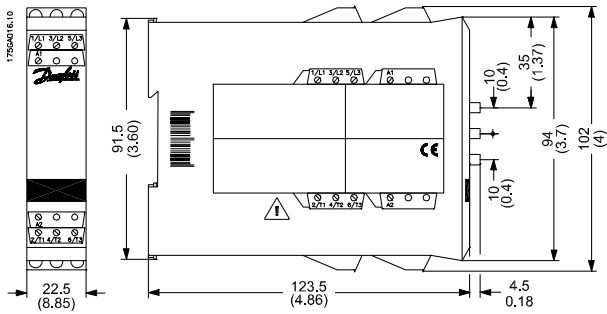

Illustration 1.3 MCD 100 - 001

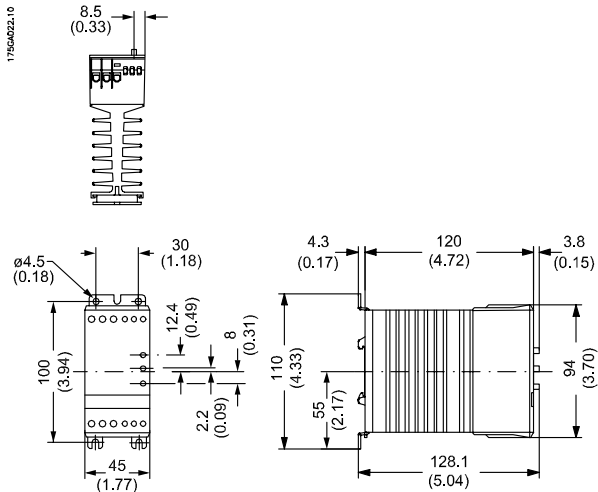

Illustration 1.4 MCD 100 - 007

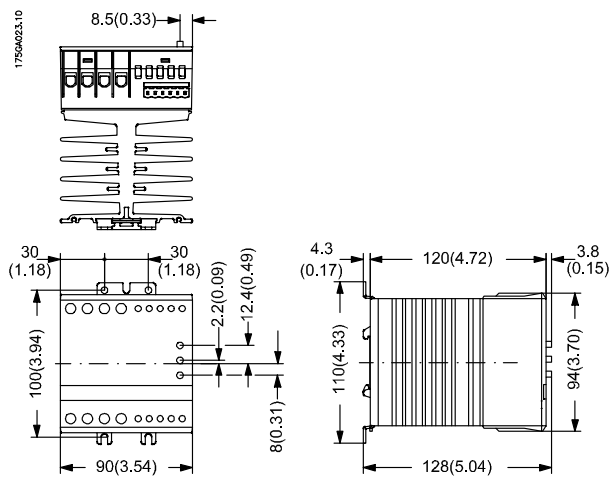

Illustration 1.5 MCD 100 - 011

1.3.8 Operating at High Temperatures

Ambient temperature	Continuous current		
	MCD 100 - 001	MCD 100 - 007	MCD 100 - 011
40°C	3 A	15 A	25 A
50°C	2.5 A*	12.5 A	20 A
60°C	2.0 A*	10 A	17 A

Table 1.11

* Minimum 10 mm side clearance between products

Ambient temperature	Duty-cycle rating (15 min. max. on-time)	
	MCD 100 - 007	MCD 100 - 011
40°C	15 A (100 % duty-cycle)	25 A (100 % duty-cycle)
50°C	15 A (80 % duty-cycle)	25 A (80 % duty-cycle)
60°C	15 A (65 % duty-cycle)	25 A (65 % duty-cycle)

Table 1.12

1.3.9 Over Heat Protection

If required the controller can be protected against overheating by inserting a thermostat in the slot on the right-hand side of the controller.

Order: UP 62 thermostat 037N0050

Depending on the application the thermostat can be connected in series with the control circuit of the main contactor. When the temperature of the heat sink exceeds 90° C the main contactor will be switched OFF. A manual reset is necessary to restart this circuit.

For wiring connections see 1.4 Application Examples.

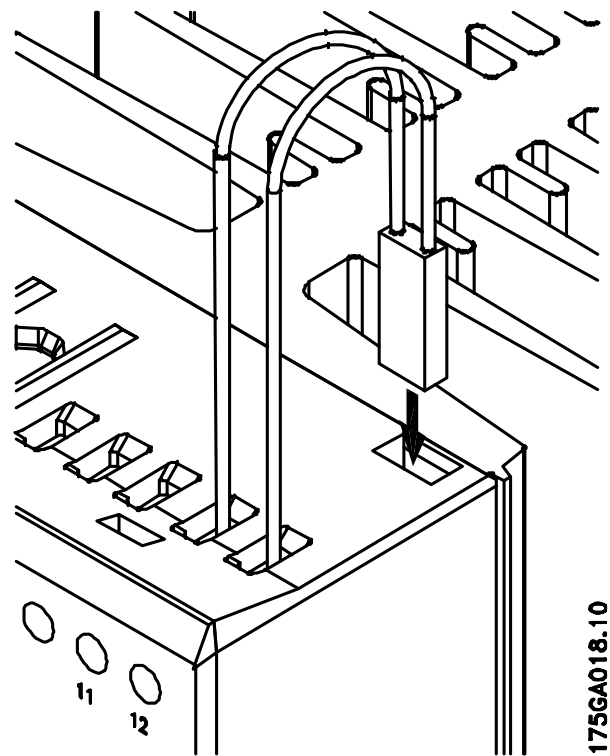

Illustration 1.6

1.3.10 Mounting Instructions

The controller is designed for vertical mounting. If the controller is mounted horizontally the load current must be reduced by 50%.

The controller needs no side clearance.

Clearance between two vertical mounted controllers must be minimum 80 mm (3.15").

Clearance between controller and top and bottom walls must be minimum 30 mm (1.2").

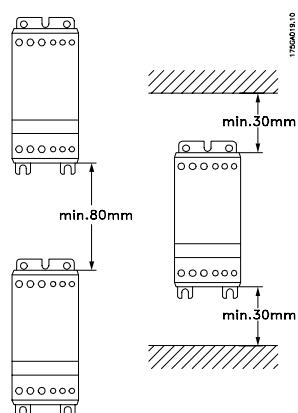

Illustration 1.7

When the contactor C1 is switched to the OFF-State, the motor will be switched off instantaneously.

In this application the contactor will have no load during making operation. The contactor will carry and break the nominal motor current.

1.4 Application Examples

1.4.1 Overheat protection

Example 1

The thermostat can be connected in series with the control input of the soft starter. When the temperature of the heat sink exceeds 90°C the soft starter will be switched OFF.

NOTE

When the temperature has dropped approximately 30°C the controller will automatically be switched On again. This is not acceptable in some applications.

Example 2

The thermostat is connected in series with the control circuit of the main contactor. When the temperature of the heat sink exceeds 90°C the main contactor will be switched OFF. This circuit requires manual reset to restart the motor.

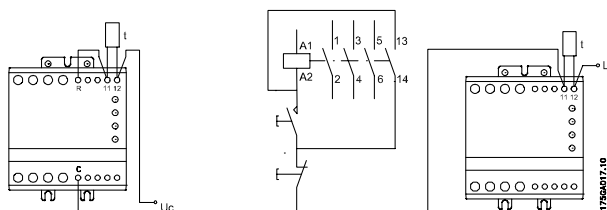

Illustration 1.8

1.4.2 Line Controlled Soft Start

When the contractor C1 is switched to the ON-State, the soft starter will start the motor, according to the settings of the Ramp-up time and Initial torque adjustments.

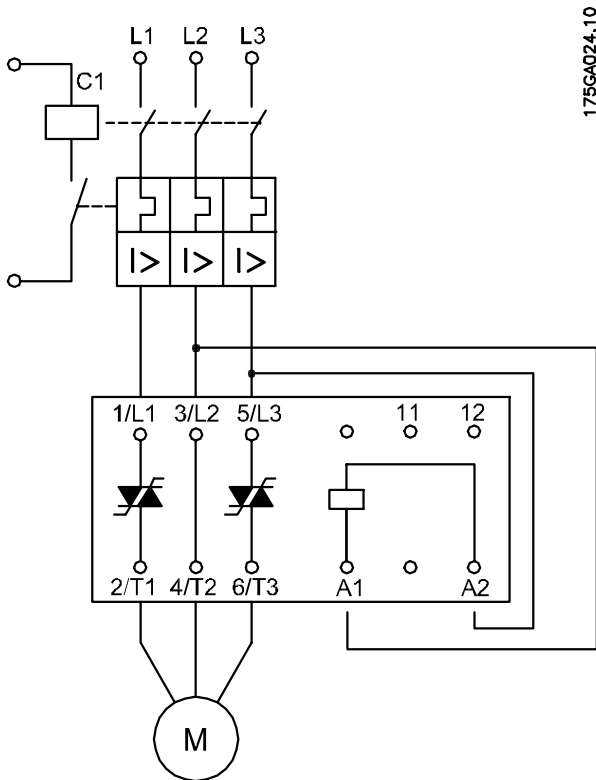

Illustration 1.9

1.4.3 Input Controlled Soft Start

When the control voltage is applied to A1 - A2, the MCD soft starter will start the motor, according to the settings of the Ramp-up time and Initial torque adjustments.

When the control voltage is switched OFF, the motor will be soft stopped according to the settings of the Ramp-down time adjustments.

To switch off instantaneously set the Ramp-down time to 0.

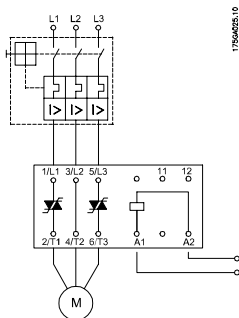

Illustration 1.10



www.danfoss.com/drives

Danfoss can accept no responsibility for possible errors in catalogues, brochures and other printed material. Danfoss reserves the right to alter its products without notice. This also applies to products already on order provided that such alterations can be made without subsequential changes being necessary in specifications already agreed. All trademarks in this material are property of the respective companies. Danfoss and the Danfoss logotype are trademarks of Danfoss A/S. All rights reserved.

