



## Data Sheet

# Thermostatic Radiator Sensor, Type RAW with RTD Connection

### Application



RAW/RTD 5215/5216

The RAW series is a programme of radiator thermostats which covers all central and district heating systems.

RAW is a self-actuating proportional controller with a small P-band.

RAW radiator thermostats are designed for use in 2-pipe domestic heating systems.

The sensors are equipped with RTD connection.

RAW 5216 is identical to 5215 except for the temperature range 16 - 28 °C.

The RAW 5215 sensor incorporates a frost protection setting for maximum user flexibility.

The RAW sensors also provide the option to limit the temperature range. On 013G5215 both maximum and minimum setting temperature can be limited. On 013G5216 only the maximum temperature can be limited.

The RAW design is particularly robust, with both End-Stop strength limits and sensor bending force limits being substantially above the requirements of the European Standard EN215.

### Ordering and Technical Data

#### Sensor range

Product	Model	Colour	Temp. range <sup>1)</sup>	Code no.
RAW 5215	Built-in temperature sensor	RAL 9016	8-28 °C	<b>013G5215</b>
RAW 5216	Built-in temperature sensor, limited temperature area	RAL 9016	16-28 °C	<b>013G5216</b>

<sup>1)</sup>  $X_p = 2 K$ . (The valve closes at 2 °C higher room temperature)

### Accessories and Spare Parts

Product	Code no.
Theft protection 	<b>013G5287</b>

Temperature Setting

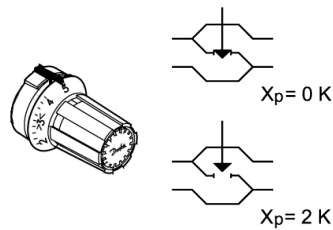

\* = Frost protection setting

10	14	18	22	26	30	°C
*	1	2 . . . 3 . . . 4			5	
8	12	16	20	24	28	°C

The required room temperature is set by turning the setting dial. The temperature scales show the correlation between scale values and the room temperature. The temperature values stated are for guidance only as the obtained room temperature will often be influenced by installation conditions.

The temperature scales are stated according to European standards at  $X_p = 2^\circ\text{C}$ . This means that the radiator thermostats close at a sensor temperature which is  $2^\circ\text{C}$  higher than stated on the temperature scales.

Mounting

1.

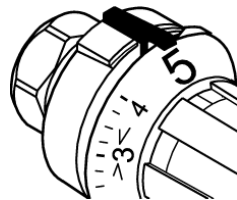

3.

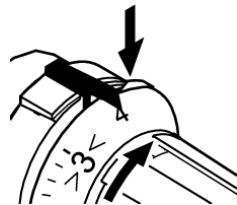

2.

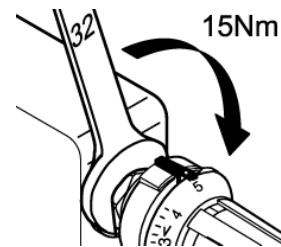

4.

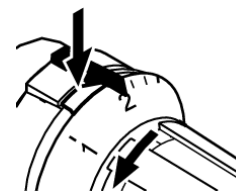

RAW5215 only

An open-end spanner is used for mounting the sensor onto the valve body (1 & 2). The sensor should always be placed where the room air can circulate freely around it.

**Setting the upper and lower limit**

The thermostat features two tabs with which the temperature setting area can be decreased. If 4 should be max. setting, turn the thermostat to max. position (3) and press and hold right tab while turning the thermostat to 4 (3), now release tab. With the left tab the lower temperature must be turned to min. position (4).

Design and Function

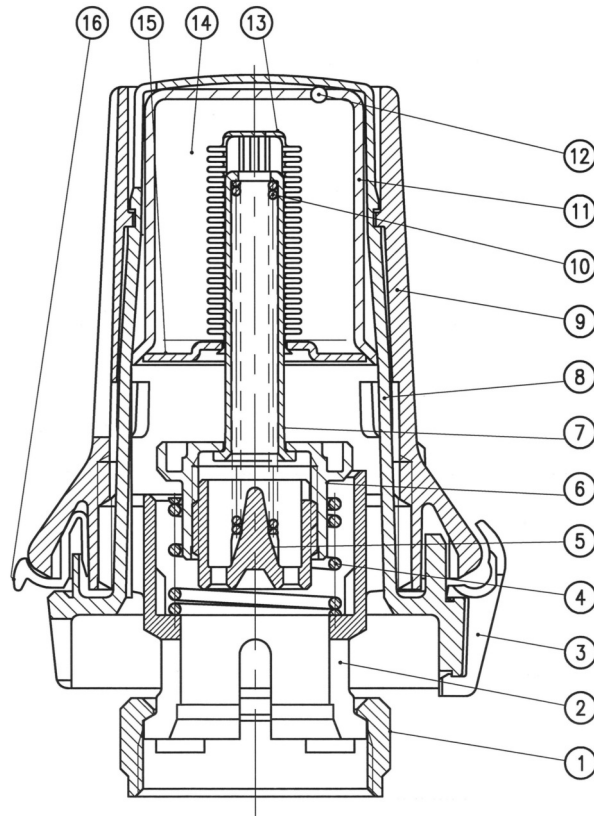

- 1. Union nut
- 2. Socket
- 3. Setting mark
- 4. Auxiliary spring
- 5. Spindle screw
- 6. Spindle nut
- 7. Spring housing
- 8. Cover
- 9. Handle
- 10. Spring
- 11. Capsule
- 12. Ball
- 13. Bellows
- 14. Filling
- 15. Bellows ring
- 16. Limiter tab

The RAW thermostatic sensor operates with a liquid filled bellows system, which provides proportional control, as opposed to On/Off. The sensor is actuated by ambient temperature changes. The calibrated pressure in the bellows corresponds to the temperature of the charge. This pressure is balanced by the force of a regulating spring.

On a rise in ambient temperature, the pressure increases in the bellows, moving the valve cone towards the "closed" position, until equilibrium exists between the bellows and spring. On a drop in ambient temperature, the pressure falls, allowing the bellows to contract and the valve cone to move towards the "open" position until a state of equilibrium is re-established.

Dimensions

013G5215

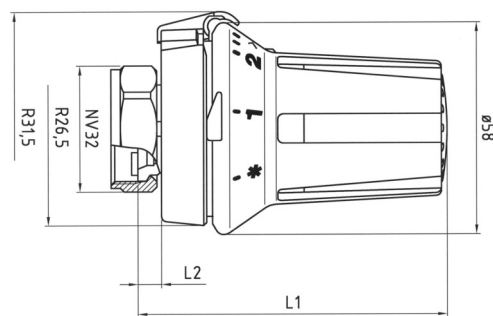

013G5216

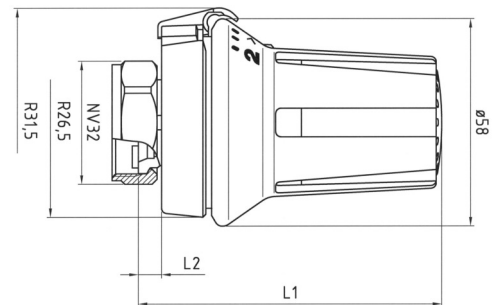

Setting	L <sub>1</sub>	L <sub>2</sub>
*	81.6	3.7
3	84.3	6.4
5	86.2	8.3

Setting	L <sub>1</sub>	L <sub>2</sub>
"min."	82.9	5.0
3	84.3	6.4
5	86.2	8.3

Danfoss A/S  
Heating Solutions  
Haarupvaenget 11  
8600 Silkeborg  
Denmark  
Phone: +45 7488 8000  
Fax: +45 7488 8100  
Email: [heating.solutions@danfoss.com](mailto:heating.solutions@danfoss.com)  
[www.heating.danfoss.com](http://www.heating.danfoss.com)

---

Danfoss can accept no responsibility for possible errors in catalogues, brochures and other printed material. Danfoss reserves the right to alter its products without notice. This also applies to products already on order provided that such alterations can be made without subsequential changes being necessary in specifications already agreed. All trademarks in this material are property of the respective companies. Danfoss and the Danfoss logotype are trademarks of Danfoss A/S. All rights reserved.

---