

Data sheet

Electrical actuator AME 855

Description



Actuator is primarily designed to regulate valve in the respond to the demand of a controller in District Heating/cooling, Heating, Ventilation and Air conditioning systems.

Actuator AME 855 can be controlled by electronic controllers with modulating or 3-point control output.

Actuator can be used with VF3 valves (DN 200-300).

Features:

- 3-point or modulating control
- Easy to use manual operation (monitoring on terminal R)
- Position indication
- LED signaling
- Direct or inverse function
- Automatic adaptation of stroke to valve's end positions which reduces commissioning time
- Voltage or current input Y
- Voltage or current output X (for current output, accessory is needed)
- Frost protection function (for detailed information read the Functions section in the data sheet)
- Blockage detection
- Internal temperature control – integrated heater + overheat protection
- Wire break detection (only modulating actuator)
- Selectable hysteresis
- Auto test function
- Auto pause function
- Potential-free position switches (accessory)
- Remote reset possibility

Main data:

- Nominal voltage:
 - 24 V AC
 - 115 V or 230 V AC
- Control input signal: 3-point or modulating
- Force: 15.000 N
- Stroke: 80 mm
- Speed: 2 s/mm
- Max. medium temperature: 130 °C

Ordering

Actuator

Picture	Type	Power supply (V)	Code No.
	AME 855	24	082G3510
		230/115	082G3511

Accessories

Type	Code No.
Current output PCB	082G3512
Position switches (2x) PCB	082G3513

Technical data

Power supply	V	24 (AC) or 115 / 230 (AC); ±10%
Power consumption	VA	50 (24V) 63 (230V)
Frequency	Hz	50 / 60
Control input Y ¹⁾		0 – 10 V DC; 77 kOhm 2 – 10 V DC; 77 kOhm 0 – 20 mA; 510 Ohm 4 – 20 mA; 510 Ohm
Control output X		0 – 10 V DC; ≥1200 Ohm; I = 8 mA (max.) 0 – 20 mA; ≤500 Ohm 4 – 20 mA; ≤500 Ohm
Closing force	N	15000
Max. stroke	mm	80
Speed	s/mm	2
Max. medium temperature		130
Ambient temperature	°C	-10 ... +50
Storage and transport temperature		-20 ... +65
Protection Class		II
Grade of enclosure		IP 54
Weight	kg	11 (24V) 11,4 (230V)
Manual operation		Mechanical
- marking in accordance with the standards		Directive 2006/42/EC Council Directive 2004/108/EC Council Directive 2006/95/EC

¹⁾ when Y is selected as 2-10 V DC or 4-20 mA, X signal is starting from 0-10V DC or 0-20 mA

Disposal

The actuator must be dismantled and the elements sorted into various material groups before disposal. Before disassembly please contact Danfoss support for disassembly instructions.

Commissioning

Complete the mechanical and electrical installation (see instructions) and perform the necessary checks and tests:

- Turn on the power
- Press initialization button (INIT)
- Set the appropriate control signal and check the valve stem direction is correct for the application

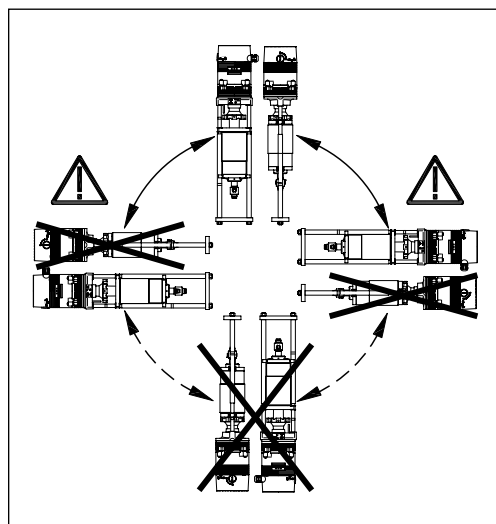
Installation

Mechanical

Please check what are allowed installation positions for the valve in combination. Use appropriate key (not supplied) to fit the actuator to the valve body. Allow for necessary clearance for maintenance purposes. To link valve and actuator stems use appropriate key (not supplied). The actuator has position indication rings which should be pushed together before el. connection; after self-stroking they indicate end positions of the stroke.

Electrical

Electrical connections can be accessed by removing the cover. Four cable entries on removable gland support are provided for M 16×1,5 cable glands. Note that in order to maintain the enclosure IP rating, appropriate cable glands must be used.

Design

1. Actuator housing
2. Cross head
3. Coupling piece
4. Union nut
5. Spindle nut
6. Position indicator
7. Protecting tube
8. Distance sleeve
9. Bridge
10. Gear housing
11. Sheeting
12. Knob
13. Hand wheel
14. Viewing panel
15. Guiding sleeve
16. Engine / motor
17. Push-fit PCB for 24 V or 230 V
18. Main board
19. Cover for 24 V or 230 V
20. Cable lead-in M20 × 1.5
21. Cable lead-in M16 × 1,5
22. Safety disk
23. Blank
24. Bolt
25. Hexagon nut M12
26. Type plate
27. Wiring diagram on cover

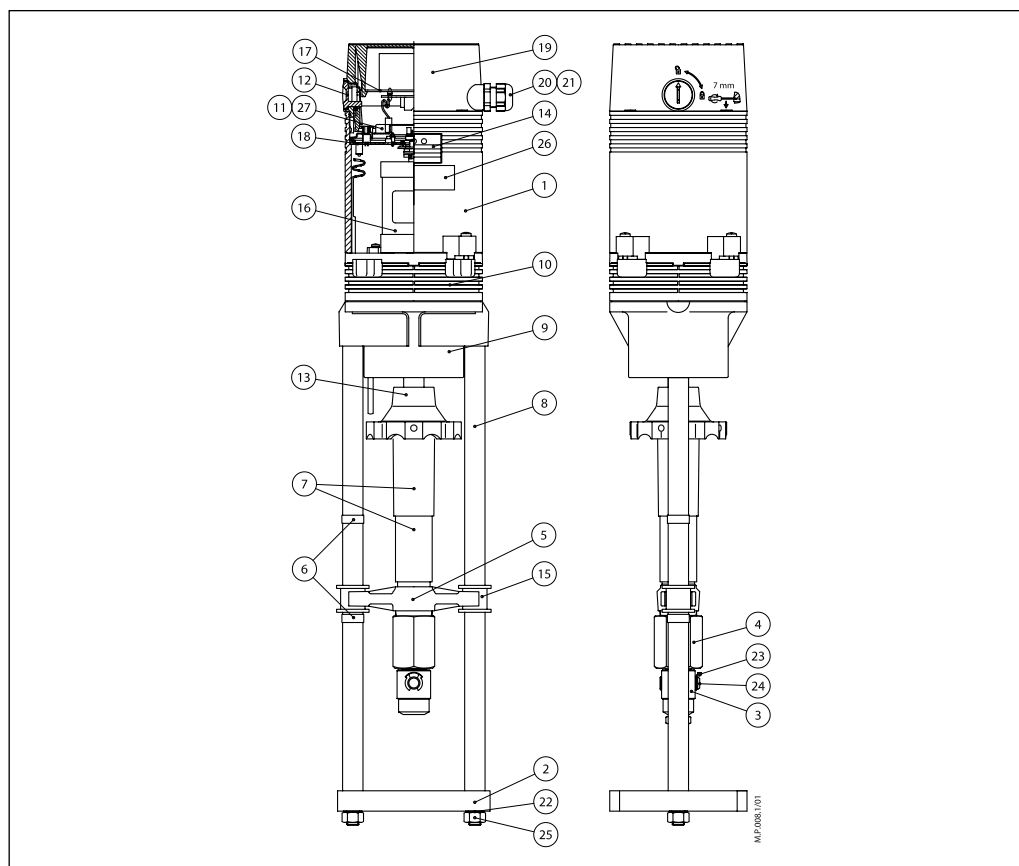

Wiring



230 VAC version:

Do not touch anything on the PCB!

Do not remove the cover before the power supply is fully switched off.



230V AC
24V AC

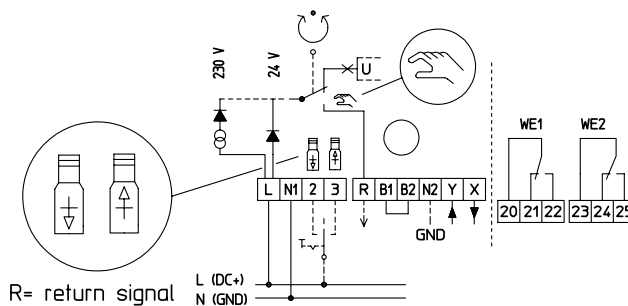



Terminal	Description
L, N1	Supply voltage
2	Control voltage for downward movement during three-point mode
3	Control voltage for upward movement during three-point mode
R	Return signal during "manual" mode • R= 24 V DC max. 35 mA
B1, B2	Binary input / frost protection function
N2	Zero potential of signals X, Y and R • When the zero potentials of signals X, Y and R are identical to the zero potential of the supply voltage it is possible to bridge terminals N1 and N2 (230V only). • If you run the actuator in continuous mode at 230 V you will have to connect N2. • If you run the actuator in three-point mode at 230 V you will have to connect N2 if you wish to use X or R at the same time.
Y	Input signal continuous mode
X	Output signal continuous mode
20, 21, 22	Terminals path switch unit WE1
23, 24, 25	Terminals path switch unit WE2

**Led signalling/
Actuator operating modes**

LED operating mode indicator:

The two-colour (green / red) LED function indicators are located in the actuator cover. They indicate different operating modes:

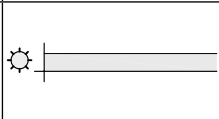
- Normal operation (green LED is permanently lit, actuator waiting for Y signal command)
- Standard operation (blinking green LED with short-short rhythm - 0.5s LED is ON and 0.5s LED is off - actuator is following Y signal command)
- Wire break detection (blinking green LED with short-long rhythm - 0.2s LED is ON and 1.5s LED is OFF – input signal Y has dropped below 1V or 2 mA in operating mode 2-10V or 4-20mA)
- Blockage detection only in modulating control (blinking green LED with long-long rhythm – 2.5s LED is ON and 2.5s LED is OFF – actuator is mechanically blocked)
- Remote reset function - continuous signal on terminals 2,3 (blinking green LED with long-short rhythm – 2.5s LED is ON and 0.5s LED is OFF – a simultaneous signal at terminals 1 and 3 will result in reset or initialization process where actuator will adapt its stroke to valve end positions. Actuator will switch off after 4 unsuccessful attempts)
- Temperature is in normal range (red LED is off)
- Heating mode (red LED is ON)
- Actuator is overheating (blinking red LED with short-short rhythm – 0.25s LED is ON and 0.25s LED is OFF – overheating protection mode)

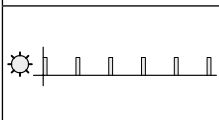
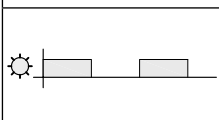
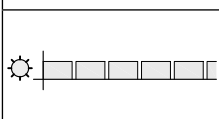
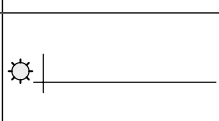
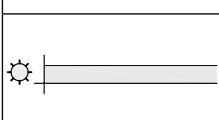
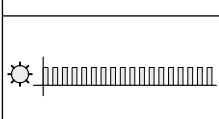
LED	Indication type	Operating status / error
Green LED:		Constantly lit Normal operation, ready for operation The LED is permanently lit, actuator waiting for command signal.
		Flashing 0,5s / 0,5s / 0,5s / 0,5s ... Standard Operation Actuator carries out traverse command.
		Flashing 0,2s / 1,5s / 0,2s / 1,5s ... Wire break detection Input signal has dropped below 1 V or below 2 mA in operating modes 2 ... 10 V DC or 4 ... 20 .
		Flashing 2,5s / 2,5s / 2,5s / 2,5s ... Blockage detection (continuous mode only) The linear actuator is mechanically blocked.
		Flashing 1,5s / 0,2s / 1,5s / 0,2s ... Continuous signal on terminal 2 and 3 A simultaneous control signal at terminal 2 and 3 will result in an initialising cycle (max. 4 attempts). The linear actuator will automatically switch off after 4 unsuccessful attempts.
Red LED:		No indication Temperature in normal range
		Constantly lit Heating mode
		Flashing 0,25s / 0,25s / 0,25s / 0,25s... Actuator overheating

DIP switch setting

Actuator has a selection of DIP switches under the cover:

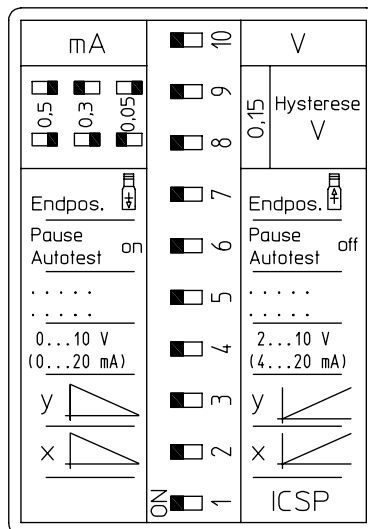

- **DIP SW 1:** Must always be in ON position for stable operation
- **DIP SW 2:** DIR / INV Y signal(direct or inverse acting mode)
 1. DIR position (ON position) – actuator is direct acting to input signal
 2. INV position (OFF position) – actuator is inverse acting to input signal
- **DIP SW 3:** DIR / INV X signal(direct or inverse acting mode)
 1. DIR position (ON position) – actuator is giving direct acting output signal
 2. INV position (OFF position) – actuator is giving inverse acting output signal
- **DIP SW 4:** 0-10 V / 2-10V or 0-20mA / 4-20 mA input signal Y
 1. 0-10V / 0-20 mA (ON position)
 2. 2-10V / 4-20 mA (OFF position)
- **DIP SW 5:** Without function, do not change switch setting
- **DIP SW 6:** Auto test function
 1. Auto test enabled (ON position)
 2. Auto test disabled (OFF position)
- **DIP SW 7:** Limit position setting
 1. Actuator spindle extended (ON position)
 2. :Actuator spindle retracted (OFF position)
- **DIP SW 8 and 9:** Hysteresis settings
 1. 0.15 V (SW 8 and 9 in position ON)
 2. 0.05 V (SW 8 in ON and SW 9 in OFF position)
 3. 0.3 V (SW 8 in OFF and SW 9 in ON position)
 4. 0.5 V (SW 8 and 9 in OFF position)
- **DIP SW 10:** Input signal Y as voltage (V) or current (mA)
 1. Drive actuator via current signal from controller (ON position)
 2. Drive actuator via voltage signal from controller (OFF position)

Functions

- **Modulating control mode:**

System controller pre-sets the position of the linear actuator whilst inside the linear actuator the input signal (Y) of the system control is continuously compared with the output signal (X) of the linear actuator. In doing so the output signal depends on the position of the linear actuator approximated to the valve end positions.
- **3-point control mode:**

The direction of the rotation is set via control voltage on terminal 2 and 3 on the main PCB. When the control voltage is applied to terminal 1 the spindle of the actuator will be extending, when control voltage is applied to terminal 3 the spindle of the actuator will be retracting.
- **Frost protection function:**

The terminals B1 and B2 on the main PCB are bridged during the normal operation. If the electric circuit between B1 and B2 is interrupted, the linear actuator will store the current position (3-point mode) and then automatically move the set end position on DIP SW 7. The actuator will stay in the selected end position as long as the circuit between B1 and B2 is interrupted. After the circuit between B1 and B2 will be restored again, the actuator will automatically go to the stored position (3-point mode) or to the desired position by the Y signal in modulating control mode. Safety thermostat could be used to control the circuit between B1 and B2 terminals.
- **Blockage detection:**

If the linear actuator is blocked during movement, the linear actuator will briefly move back and then retry to reach the desired position (will try to remove the blockage). If this procedure will be unsuccessful after 7 attempts, the linear actuator will turn off in order to prevent damage of actuator and valve. A blockage detection is indicated via green LED indication.
- **Internal temperature control:**

When the temperature inside the actuator housing exceeds a certain limit (65 °C) the motor will be turned off. After the temperature will fall down below limit, actuator will restart automatically.

When the temperature inside the actuator housing drops below 15°C the motor will be switched in the heating mode during stoppages. Actuator heating will be switched off automatically when the temperature in the housing will exceed 22°C. The actuator heating does not effect on functions of the actuator. Heating of actuator also prevents the formation of condensation inside the actuator and ensures easier movement of the gears even at temperatures down to -10°C. Heating mode and motor stoppage are displayed as a red LED signalization.
- **Wire break detection:**

Only available in modulating control mode with 2-10 V or 4-20 mA Y signal. Wire break detection is displayed as green LED indication.
- **Hysteresis setting:**

It serves to prevent permanent oscillations around set hysteresis thresh-hold on DIP SW 8 and 9 when there are minor Y signal changes.
- **Auto test function:**

If a valve does not operate for a while the cone of the valve might get stuck. Auto test function acts a prevent measure for that to happen. Linear actuator will after 10 days of no activity move to the end position of the valve set on DIP SW 7 and then move to the previous initial position.
- **Auto pause function:**

This function is used to prevent over-oscillating behaviour of the actuator in response to the Y control signal. If there are more than 20 direction varying Y signal commands per minute, actuator will go in a pause for 3s and then continue to follow Y signal.

Manual operation

Actuator AME 855 can be manually operated when the manual operation clutch is in upper position. Actuator has default factory setting in automatic mode (manual operation clutch in down position). If the actuator is under supply

voltage when in manual operation mode, R terminal will give position output signal. After the manual operation, the manual operation clutch must be put in down position for the automatic mode to be applied again.

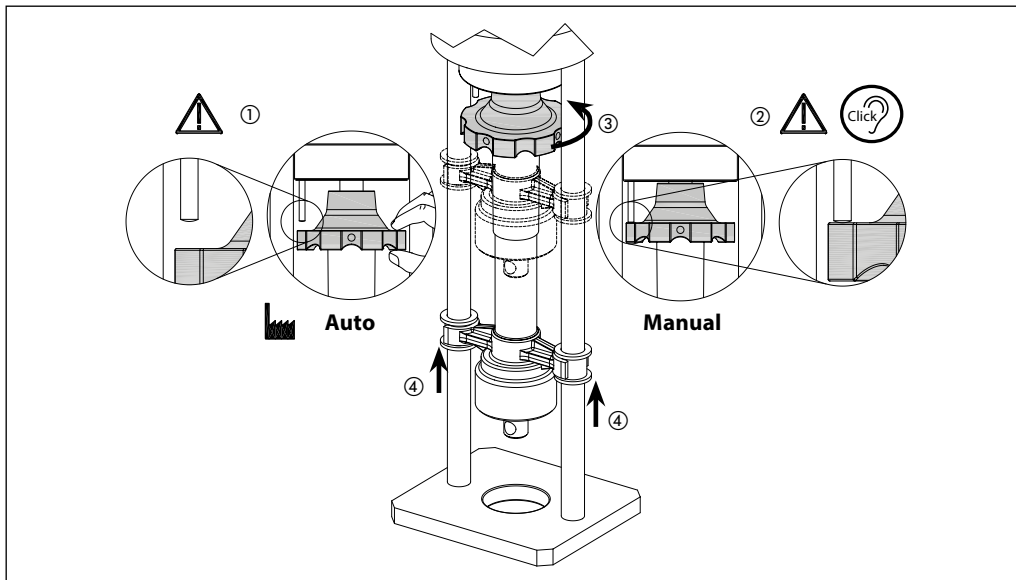

Dimensions

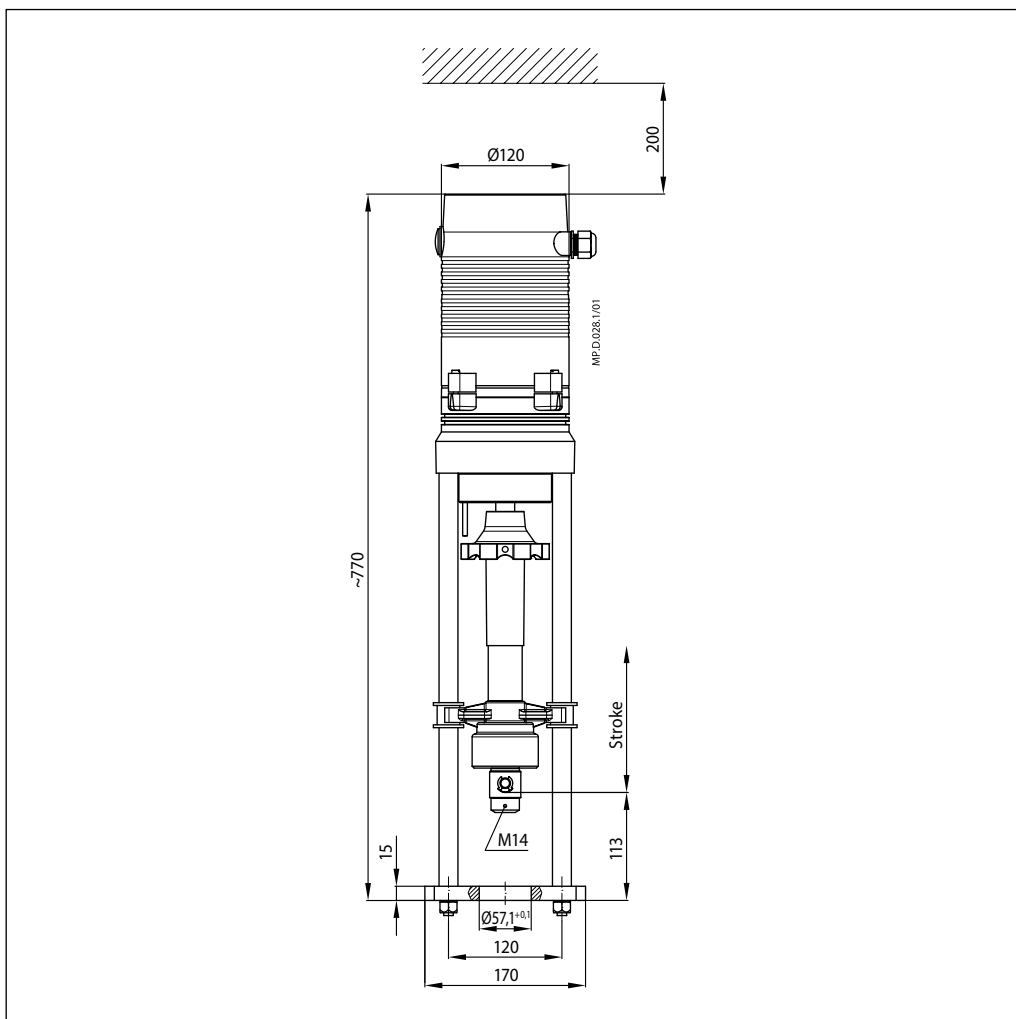

Actuator - valve combination

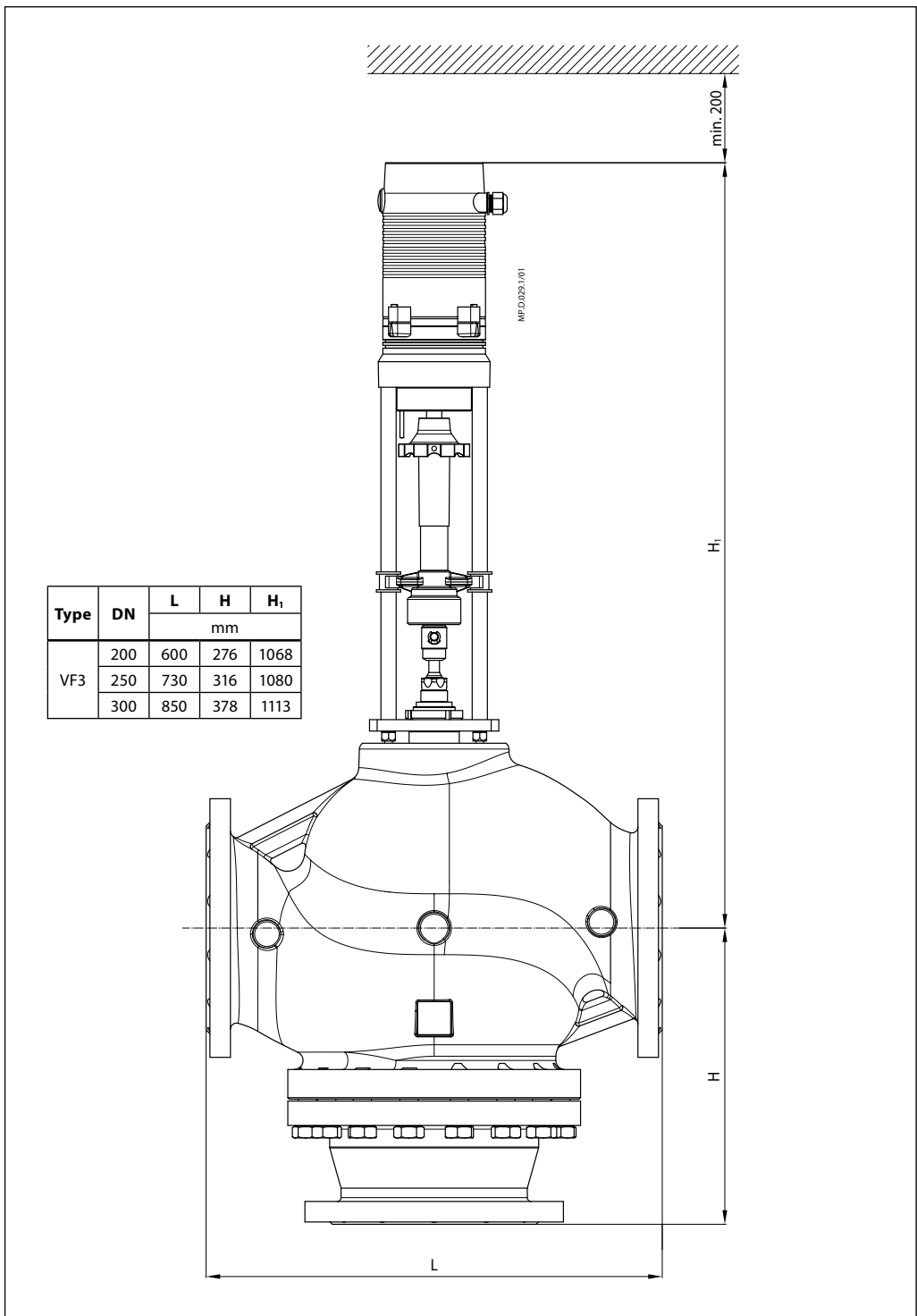

Danfoss can accept no responsibility for possible errors in catalogues, brochures and other printed material. Danfoss reserves the right to alter its products without notice. This also applies to products already on order provided that such alterations can be made without consequential changes being necessary in specifications already agreed. All trademarks in this material are property of the respective companies. Danfoss and the Danfoss logotype are trademarks of Danfoss A/S. All rights reserved.