

Data Sheet

Liquid level controller Type **EKE 347**

An intuitive and easy to navigate controller with
Modbus network capability



The EKE 347 controller is used for regulation of the liquid level in:

- Pump reservoirs
- Separators
- Intermediate coolers
- Economisers
- Condensers
- Receivers

The controller is communicating with a transmitter that continuously measures the liquid level in the actual reservoir.

By comparing the measured value with the level setpoint entered by the customer, the controller dictates the valve to increase or decrease the liquid flow to or from the reservoir.



Features

- Liquid level control
- Alarm if the set alarm limits are exceeded
- Relay outputs for upper and lower level limits and for alarm level
- User friendly and easy setup Wizard for first time configuration
- PI control
- Low or High side control
- When AKV/A is selected, a MASTER/SLAVE system can run up to 3 AKV/A with distributed Opening Degree
- Manual control of output
- Limitation of Opening degree possible
- ON/OFF operation with hysteresis
- Programming menu with 3 access levels and separate passwords
- Connection to other EKE 347 controllers possible
- Wired remote display possible
- BUS communication:
 - CAN Bus (Danfoss internal only)
 - MODBUS RTU RS485 for communication with e.g. PLC

Functions

Table 1: Functions

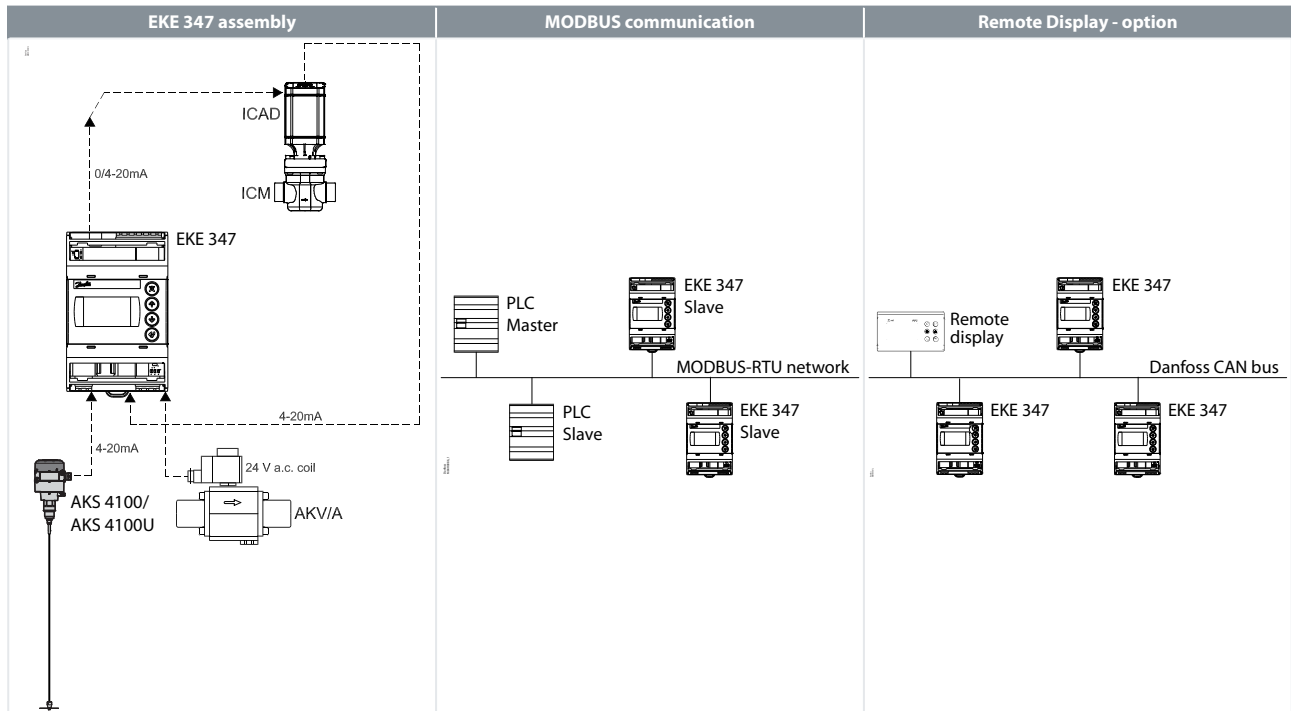

Table 2: Functions

Signaltransmitter	With the guided micro wave rod AKS 4100/4100U it is possible to set the refrigerant level within a wide range.
EKE 347	The controller receive a signal which enable it to control low or high side applications (see page 3). EKE 347 does support 2 types of Danfoss expansion valves. (see below) One analog input is available as feed back from ICM in order to indicate opening degree of the ICM.
Expansion valves	Two types of Danfoss expansion valves can be used ICM ICM are direct operated motorized valves driven by digital stepper motor type ICAD AKV/A AKVA or AKV are pulse-width modulating expansion valves.
MODBUS communication	EKE 347 include as standard RS 485 based MODBUS-RTU bus communication interface to third party equipment like PLC. Via the MODBUS it is possible to read and write parameters to the EKE 347 Operation, monitoring and data collection can then be performed via PLC from a SCADA system.
Remote Display - option	A remote display for panel mounting is available. From the remote display a full overview and access is possible to all individual EKE 347 controllers connected to the internal Danfoss CAN bus.

Applications

Pump reservoir

Modulating control of injection for a more stable liquid level and suction pressure.

Figure 1: System configuration ICAD

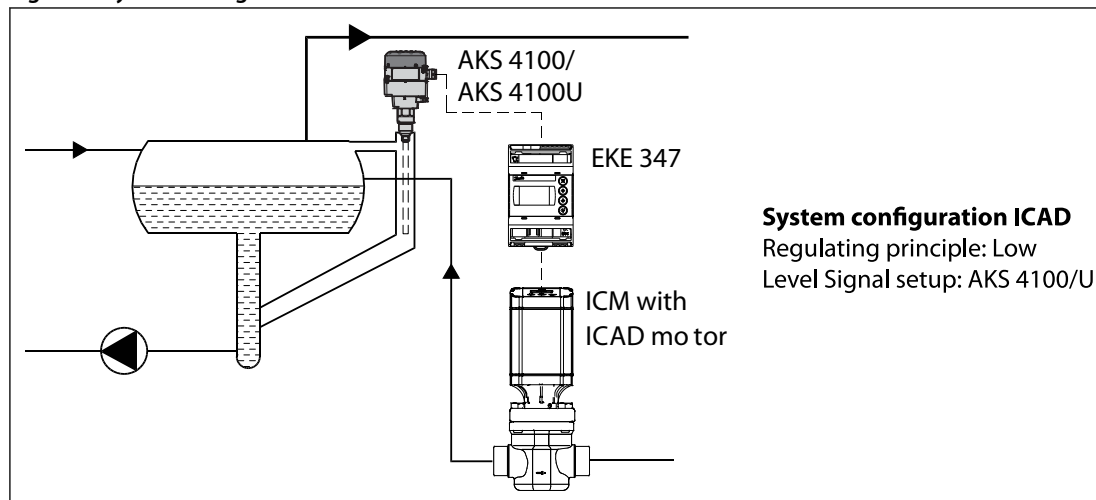

Separator on flooded evaporator

Modulating control and the valve's large capacity range ensure a stable level - even under conditions of quickly changing loads.

Figure 2: System configuration AKV/A

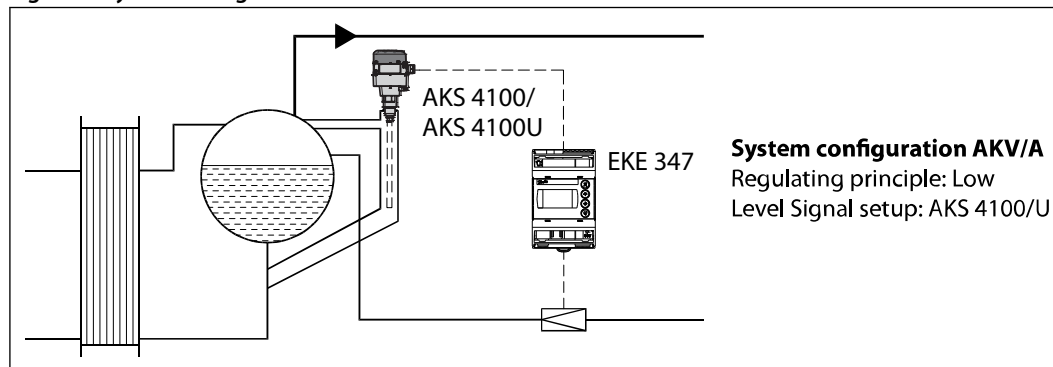

Intermediate cooler

The level transmitter's wide measuring range enables it to monitor the liquid at all levels of the reservoir - and hence to use the signal for safety functions in connection with the max. permissible level.

Figure 3: System configuration AKV/A

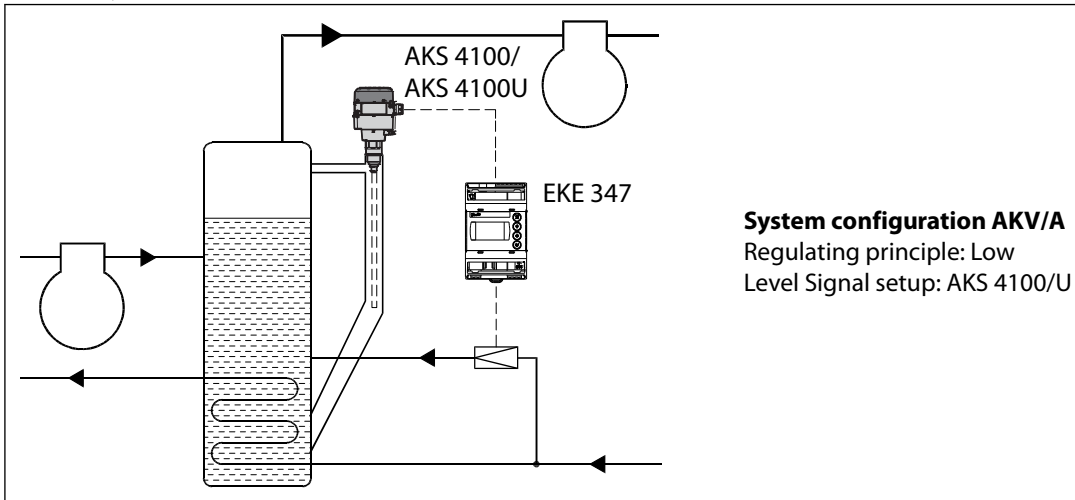

Receiver / condenser

The control system's short reaction time makes it very suited for high-pressure float systems with small refrigerant charges.

Figure 4: System configuration AKV/A

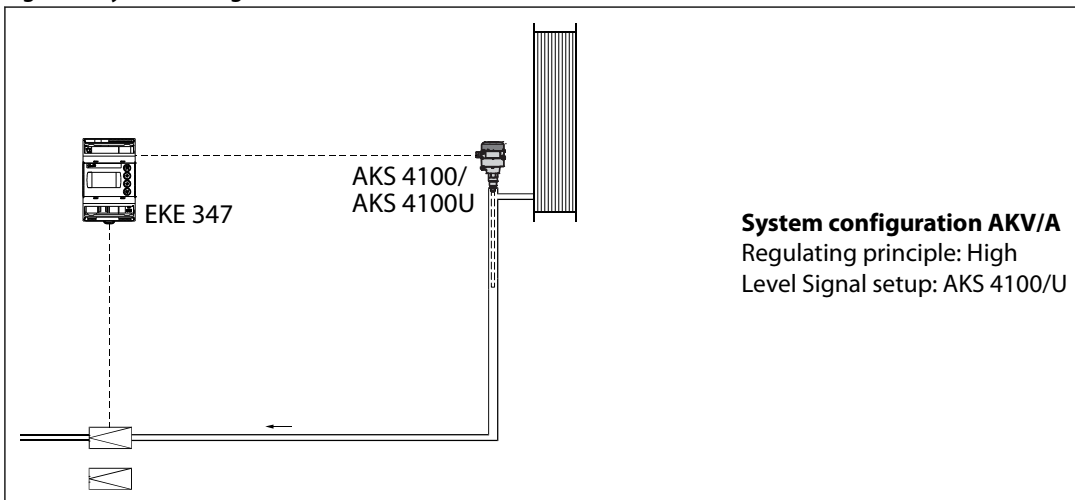

Product specification

Electrical connection

Table 3: Electrical connection

Supply voltage	24 V AC $\pm 20\%$ 50 / 60 Hz or 24 V DC $\pm 20\%$ (the supply voltage is galvanically separated from the input and output signals. Input/output are not individual galvanic isolated)	
Power consumption	Controller	15 VA / 10W
	20 W coil for AKV or AKVA	55 VA
Input signal	Level signal *	4 – 20 mA or 0 – 10 V
* Ri =	ICM valve feedback signal *	From ICAD 0/4 – 20 mA
0(4) – 20mA: 33 ohm		
0(2) – 10 V: 100 kohm	Contact function start / stop of regulation	
Relay output	3 pcs. SPDT (Lower level alarm, Upper level alarm, Common alarm / NC Solenoid)	Normally Open: 3 A GP*, 2.2 FLA / 13.2 LRA, 1/6 hp, PD 220 VA, 250 V AC 100 k 3 FLA / 18 LRA, 1/10 hp, PD 150 VA, 125 V AC 100 k Normally Closed: 3 A GP*, 250 V AC 100 k (*GP = General purpose) Max 240 V AC or 24 V AC / DC can be used, but same voltage type must be used on DO3 and DO2
Current output	0 – 20 mA or 4 – 20 mA	
	Max. load: 500 ohm	

Material specification

Table 4: Material specification

Valve connection	ICM - via current output AKV/A- via 24 AC Pulse-Width Modulating output	
Data communication	MODBUS RTU: Communication to system controller, MODBUS on RS485: galvanic isolation (500 V DC) CAN: Communication to other EKE controllers	
Supported Modbus Commands	Supported commands with max of 50 ms response time	03 (0x03) Read Holding Registers 04 (0x04) Read Input Registers 06 (0x06) Write Single Register 08 (0x08) Diagnostics
	Supported commands without defined max response time	16 (0x10) Write Multiple Registers (up to 20 registers) 43 (0x2b) Read Device Identification
Environments	-20 °C – 55 °C, during operation -30 °C – 80 °C, during storage 90% Rh, not condensed No shock influence / vibrations	
Enclosure	IP20 / IP40 for the front mounted into a panel	
Weight	193 g	
Mounting	DIN rail	
Display	Graphical LCD display	
Terminals	plugs 1.5 or 2.5 mm ² multicore	

Connection

Table 5: Necessary connections

Terminals	
28-29	Supply voltage 24 V a.c. or d.c.
1-7	Signal from level transmitter type AKS 4100/4100U
7-10	Signal from level transmitter type AKS 41
36-37	Expansion valve type AKV or AKVA
23-24	Expansion valve type: ICM with ICAD
13-14	Switch function for start/stop of controller. If a switch is not connected, terminals 13 and 14 must be shortcircuited

NOTE:

See the figures on the next pages.

Liquid level controller, Type EKE 347

Table 6: Application dependent connections

Terminals	
33-35	Relay for common alarm. Installer can choose between Normally Open (33-34) or Normally Closed (34-35) circuits. The relay will switch according to the programmed setting
25-27	Relay for low level limit. Installer can choose between Normally Open (26-27) or Normally Closed (25-26) circuits. The relay will switch when the set value is passed.
30-32	Relay for upper level limit. Installer can choose between Normally Open (30-31) or Normally Closed (31-32) circuits. The relay will switch when the set value is passed.
6-10	ICM valve feedback signal from ICAD 0/4 – 20 mA

Figure 5: Connections - Upper level

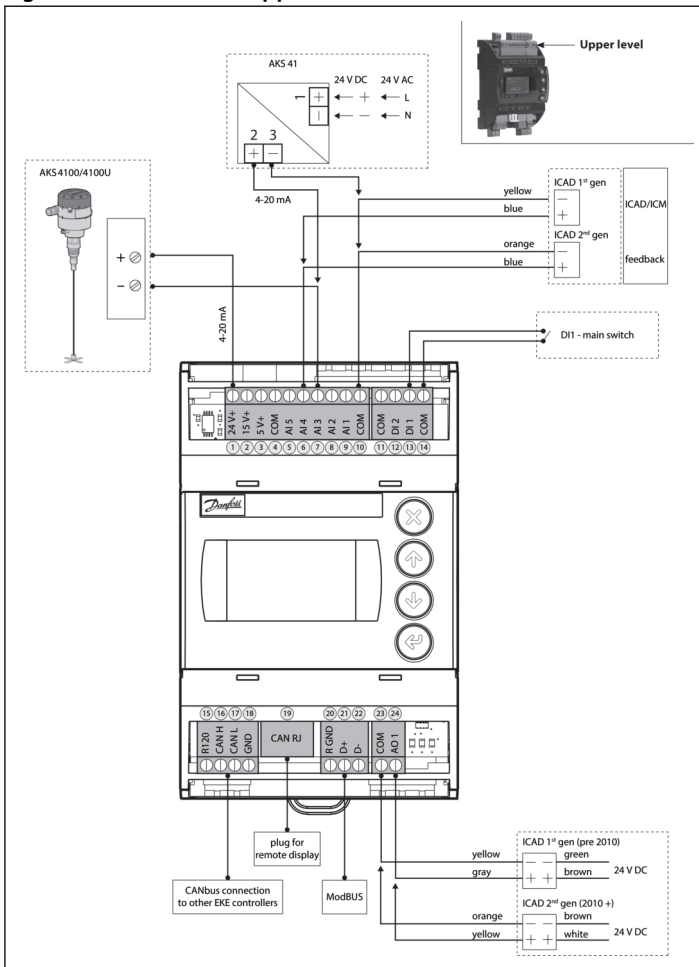

Liquid level controller, Type EKE 347

Figure 6: Connections - Lower level

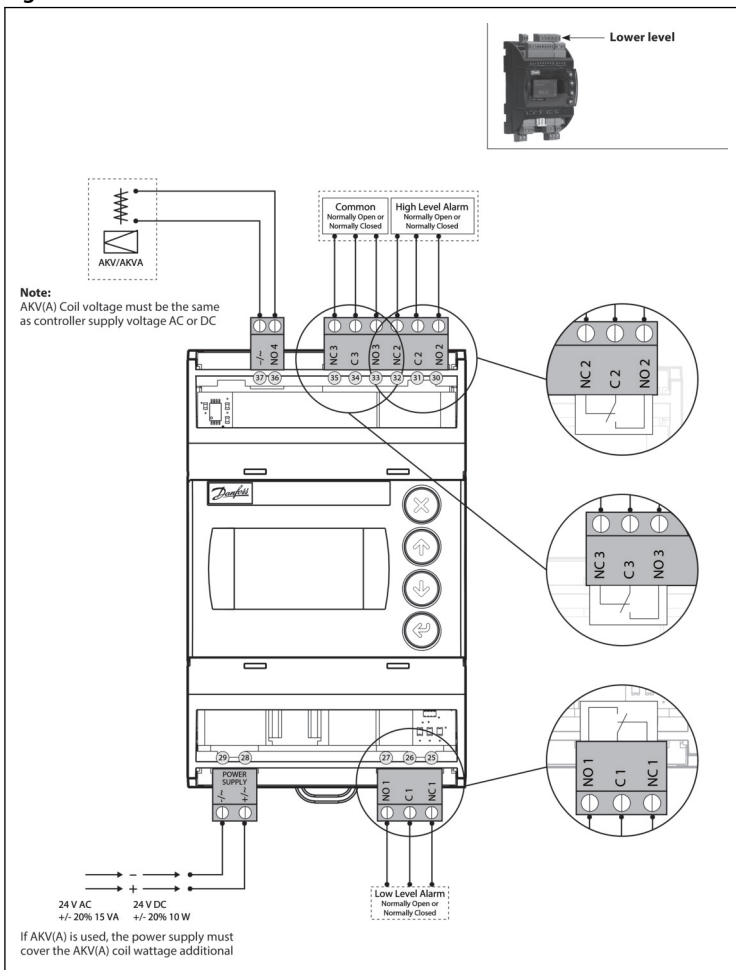

Figure 7: EKE 347 - ON/OFF Application. Open/Close solenoid valve with coil 24 V - 230V

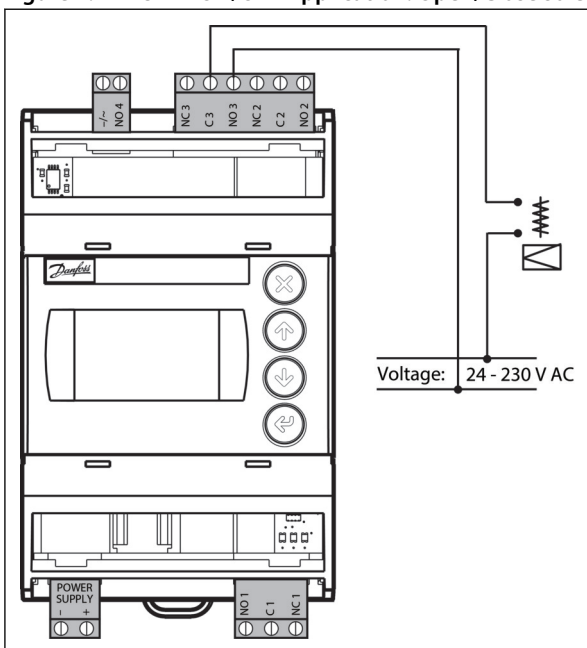
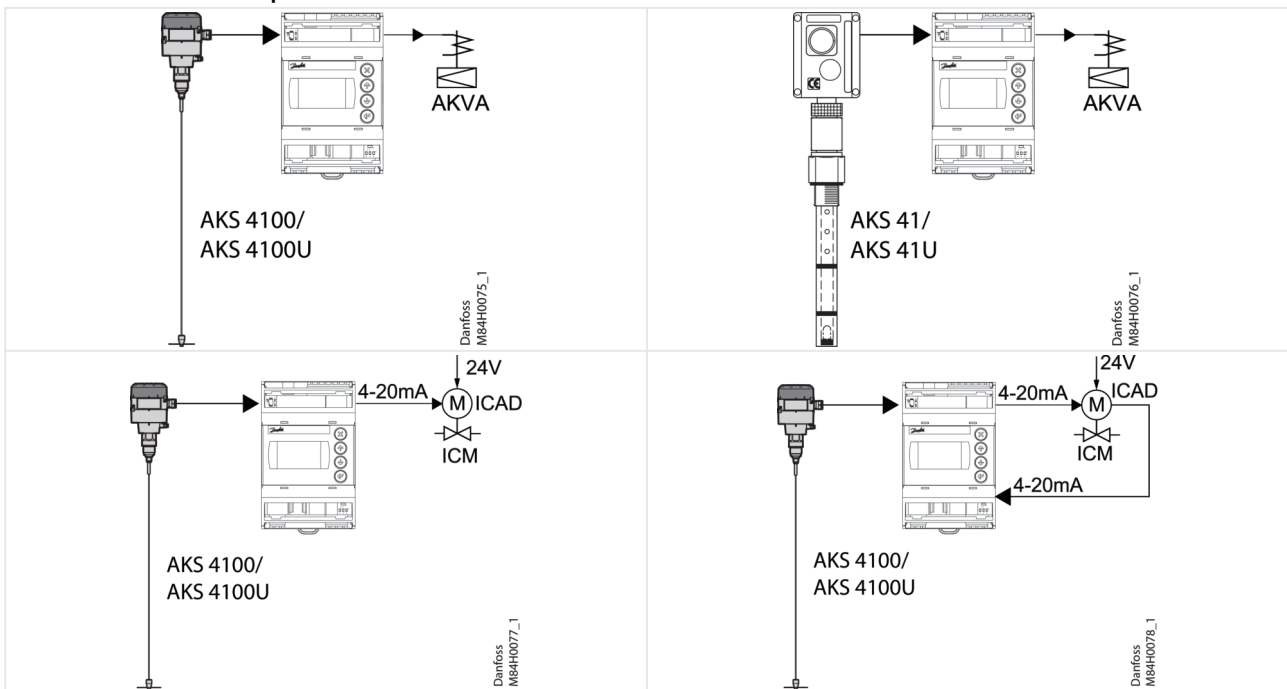

Table 7: Connection examples



Control Panel

Figure 8: Control Panel



The user interface of the control panel consists of a multiline display and 4 individual push buttons: Enter button, Scroll up button, Scroll down button and Back button.

The figure shows the Home display image, which give the actual overview. This is the starting point for entering into menus, and you will revert to this image by pushing 1 – 3 times (depending on actual position).

Display

Figure 9: Display

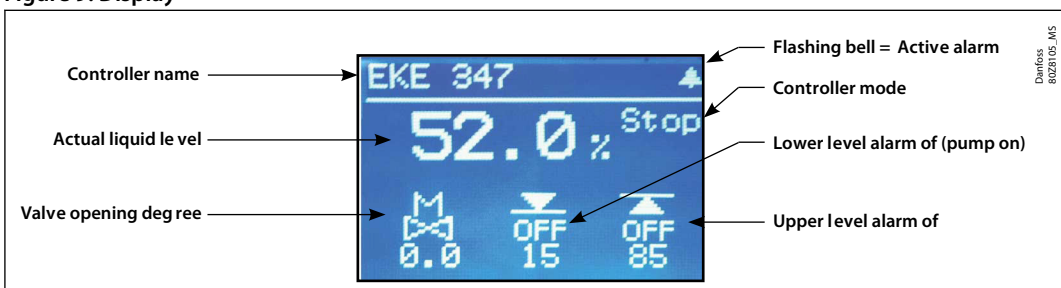

The display itself show the state of **Liquid level**, **Controller Mode** (controller On/Off), **Valve opening degree**, **Lower level alarm** (off = no alarm present) and **Upper level alarm** (off = no alarm present).

Additional to the external connected alarm audio/video sources, a Bell symbol will flash in the upper right corner in case of an alarm.

To see more details on system performance and setting of parameters, 2 different main menu levels can be reached by operation of the push buttons.

From Home image the **Status menu** can be reached by **1 push** on Enter. From Home image the **Setup & service menu** can be reached by **1 push and hold** on Enter. For entrance a Log In is required by the password given during Commissioning.

Menus

Status menu

To enter Status menu from Home image: Push once.

Figure 10: Status menu

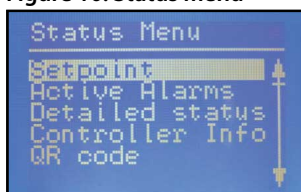

The Status menu is an open menu accessible for all. Therefore only 1 parameter can be changed from here. A selection of other parameters can be seen from the status menu.

Table 8: Status menu (Open menu)

	Options
Setpoint	
Liquid level setpoint	0 – 100% *)
Active alarms	
Example of alarm content. The list will be empty in normal operation as no alarm is active.	
Level signal out of range	hours minutes **)
Standby mode	hours minutes **)
Detailed status	
Controller state	Stop, Manual, Auto, Slave, IO **)
Actual level	0.0 – 100% **)
Actual reference	0.0 – 100% **)
Actual OD	0.0 – 100% **)
Digital input status	On / Off **)
Actual level signal current	mA **)
Oscillation amplitude	0.0 – 100% **)
Oscillation period	sec **)
Controller Info	
Type	**)
Name (Controller name)	**)
SW (Software version)	**)
Bios (Bios version)	**)
Adr (Controller address)	**)
SN (Serial Number)	**)
PV (Product version)	**)
Site (Production site)	**)
QR code	
Code	**)

i NOTE:

*) Read & write

**) Write only

Setup & service menu (Requires log-in password assigned in Commissioning menu)

To enter Setup and service menu from Home image: Push and hold

Maneuvering in the Status menu and the Setup and service menu's are done by use of the 4 push buttons shown on page 4.

Figure 11: Setup & service menu

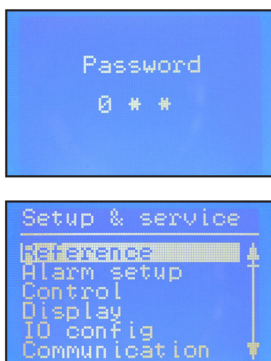

The Setup & service menu is divided into 3 access levels, where personnel have individual authority.

Most advanced level is **Commissioning**, where you have access to change all allowable parameters, including password issuing and re-run of Setup wizard.

Service level is for service personnel and has fewer rights than commissioning.

The lowest level is for **Daily** use, and allows only a few changes.

The table on the next page shows authority given to the Commissioning level.

Table 9: Setup & service menu - COMMISSIONING

Parameter	Options	Default values	Read & Write	Read only
Reference	Main switch	On, Off	Off	-
	Liquid level setpoint	0 – 100%	50.00%	-
	Operation mode	Master, IO, Slave	Master	-
Alarm setup	Lower level limit	0 – 100%	15%	-
	Upper level limit	0 – 100%	85%	-
	Level alarm mode	Time, Hysteresis	Time	-
	Lower delay	0 – 999 sec	10 sec	-
	Upper delay	0 – 999 sec	50 sec	-
	Lower level hysteresis	0 – 20%	3%	-
	Upper level hysteresis	0 – 20%	5%	-
	Function common alarm	Not follow; Follow up; Follow low; Follow all	Not follow	-
	Oscillation detect band	0 – 100%	100%	-
	Oscillation detect timeout	2 – 30 min	20 min	-
	Force pump OFF in stop mode	Yes / No	No	Yes
	IO Lower level limit	0 – 100%	5%	-
	IO Upper level limit	0 – 100%	95%	-
	IO Lower level hysteresis	0 – 20%	3%	-
IO Upper level hysteresis	0 – 20%	3%	-	
IO Lower delay	0 – 999 sec	10 sec	-	
IO Upper delay	0 – 999 sec	50 sec	-	
IO Level limit	0 – 100%	50%	-	
IO Level delay	0 – 999 sec	10 sec	-	
IO Level hysteresis	0 – 20%	3%	-	
IO Level action	Falling,Rising	Falling	-	

Liquid level controller, Type EKE 347

Parameter	Options	Default values	Read & Write	Read only	
Control	Control Method	On/Off ,P, PI	PI	Yes	–
	Regulating principle	Low, High	Low		–
	P-band	5 – 200%	30.00%		–
	Integration time Tn	60 – 600 sec	400 sec		–
	Neutral zone	0 – 25%	2.00%		–
	Difference	0,5 – 25%	2%		–
	Period time for AKV/AKVA	3–15 sec	6 sec		–
	Minimum OD	0 – 99%	0%		–
	Maximum OD	1 – 100%	100%		–
Display	Language	EN,CN,PT,RU,SP,FR,IT, GER, ARAB	EN	Yes	–
	Output indication	level, OD	Level		–
	Login timeout	1 – 120 min	10 min		–
	Backlight timeout	0 – 120 min	2 min		–
	Password daily	3 - digit, 0 – 999	100		–
	Password service	3 - digit, 0 – 999	200		–
	Password commission	3 - digit, 0 – 999	300		–
IO config	System configuration	ICAD+NC, ICAD, AKV/A+NC, AKV/A, NC only	ICAD + NC	Yes	–
	Level signal setup	AKS 4100, AKS 41, Current, Voltage	AKS4100		–
	Voltage at low liquid level	0 – 10V	0 V		–
	Voltage at high liquid level	0 – 10V	10 V		–
	Current at low liquid level	0 – 20 mA	4 mA		–
	Current at high liquid level	0 – 20 mA	20 mA		–
	Valve position setup	Not used, Current, Voltage	Not used		–
	Voltage at closed valve position	0 – 10V	0 V		–
	Voltage at open valve position	0 – 10V	10 V		–
	Current at closed valve position	0 – 20 mA	4 mA		–
	Current at open valve position	0 – 20 mA	20 mA		–
	Common alarm setup	D04, High alarm, D03, Disp only	High alarm		–
	Multiple valve setup	Not used, 2 same cap, 2 dif cap, 3 same cap, 3 dif cap	Not used		–
	Multiple valve pattern	Parallel,Sequence	Parallel		–
	Valve A capacity	0 – 100%	50%		–
	Valve B capacity	0 – 100%	50%		–
Valve C capacity	0 – 100%	30%	–		
ICAD takeover OD	0 – 100%	80%	–		
IO module setup	Used, Not used	Not used	–		

Liquid level controller, Type EKE 347

Parameter	Options	Default values	Read & Write	Read only		
Communication	CAN ID	1 – 127	1	Yes	–	
	CAN baudrate	20k, 50k, 125k, 250k, 500k, 1M	500k		–	
	Modbus ID	0 – 120	1		–	
	Modbus baudrate	0, 1200, 2400, 4800, 9600, 14400, 19200, 28800, 38400	19200		–	
	Modbus mode	8N1, 8E1, 8N2	8E1		–	
	Modbus mapping	Operation, Setup	Operation		–	
	Valve B CAN ID	1 – 127	2		–	
	Valve C CAN ID	1 – 127	3		–	
	IO Mod. CAN ID	1 – 127	4	–		
Service	Controller state		–	Yes	–	
	Actual level		–		–	
	Actual reference		–		–	
	Actual OD		–		–	
	Actual valve position		–		–	
	Digital input status		–		–	
	Actual level signal voltage		–		–	
	Actual level signal current		–		–	
	Actual position signal voltage		–		–	
	Actual position signal current		–		–	
	Actual OD A		–		–	
	Actual OD B		–		–	
	Actual OD C		–		–	
	Manual Mode	On, Off	Off		Yes	–
	Manual OD	0 – 100%	50.00%			–
	Manual low alarm	Off-On	Off			–
	Manual high alarm	Off-On	Off			–
Manual common alarm	Off-On	On	–			
Apply defaults	None, Factory	None	–			
Setup wizard	Setup wizard	Re-run Setup wizard	–	Yes	–	
I/O check	Main switch EKE act:		Off	–	Yes	
	AKS 4100 EKE act:		–			
	ICAD EKE act:		–			
	Nor. Close (NC) EKE act:		–			
	Upper lvl (alarm) EKE act:		–			
Lower lvl (alarm) EKE act:		–	–			
Controller name	Controller name	Type in controller name	–	Yes		

Alarm and error codes:

When detecting an alarm from external sources or the flashing bell in the display, the alarm description can be found as a text message in the Status menu under Active alarms.

Both alarms and errors will be shown here. If more alarms/errors occur simultaneously, they will be shown as subsequent text lines.

Table 10: Alarms:

Upper level
Lower level
Standby mode
Valve B CAN ID conflict
Valve C CAN ID conflict
IO module CAN ID conflict
IO module communication
Communication to master lost
Min / max OD conflict
Common alarm HW conflict
Control method conflict
Multiple valve setup conflict

Liquid level controller, Type EKE 347

Valve C alarm
Valve B alarm
Oscillation in level signal
Valve position
Multiple valve capacity
Valve C communication
Valve B communication

Table 11: Errors:

Internal error
Level signal out of range
Valve position signal out of range
Sensor supply overload
AKS 4100 error
Too much current AI3
Too much current AI4
DO4 overload

MASTER / SLAVE configuration

Figure 12: MASTER / SLAVE configuration

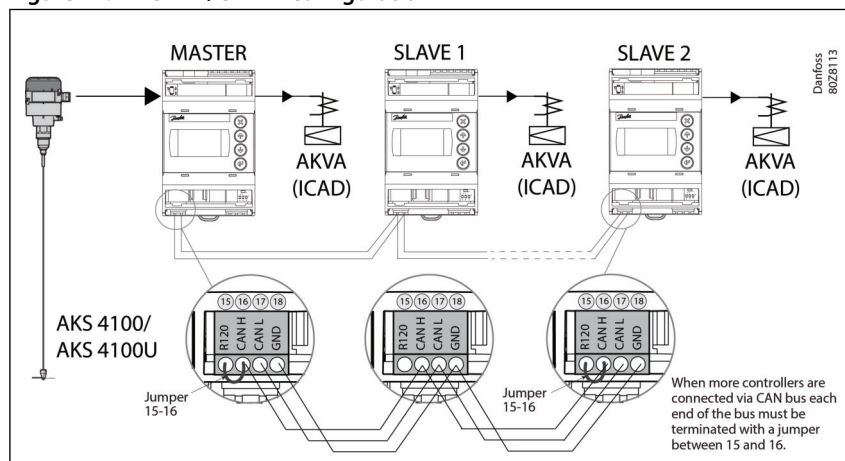

Multivalve

If the system capacity requires more than one control valve; up to three valves can be controlled simultaneously in a Master/Slave configuration, where the master and each slave controls one valve respectively.

EKE 347 IO config menu - Multiple valve setup - with one of these options:

- 2 valves with same capacity
- 2 valves with different capacity
- 3 valves with same capacity
- 3 valves with different capacity

Additionally the master must be programmed in IO config menu - Multiple valve pattern - for either:

- **Valves in parallel** (valves regulate simultaneously) **or**
- **Valves sequential** (mainly one valve regulating at any time)

See principle below.

The slave EKE's only need identification of Slave and valve CAN ID (communication menu).

Liquid level controller, Type EKE 347

Figure 13: Valves in parallel and Valves sequential

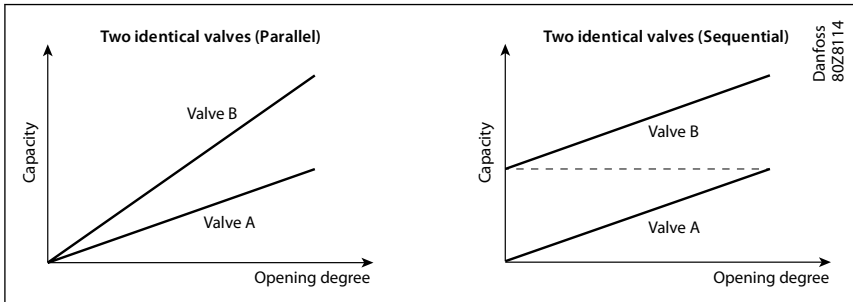

The default display of the master EKE will show the standard information together with a symbol of multiple valves and the actual total opening degree (see below).



The default display of the slave EKE will show the actual liquid level (as the master), symbol of multiple valves, actual total opening degree and the opening degree of the individual valves involved (see below).



I/O configuration

Figure 14: I/O configuration

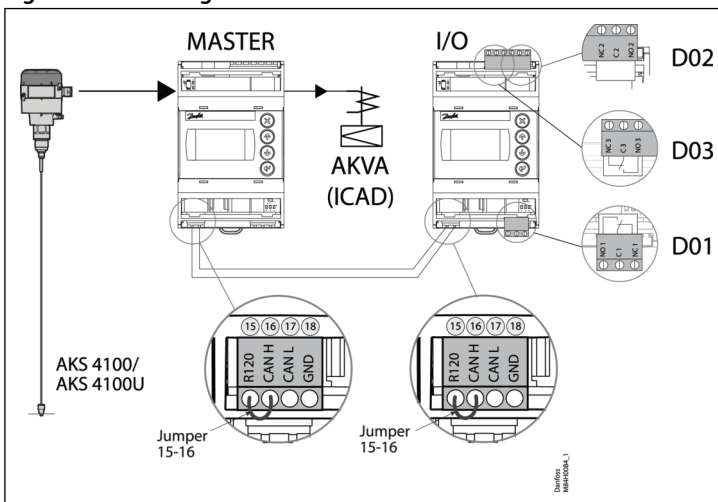

Remote display

The daily operation can be set up directly on the controller or via an external display device.

Figure 15: Example 1

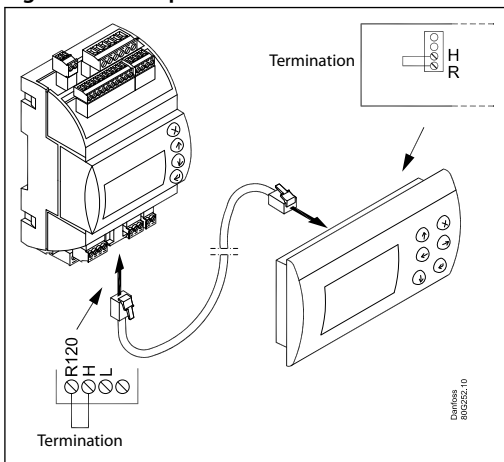

Figure 16: Example 2

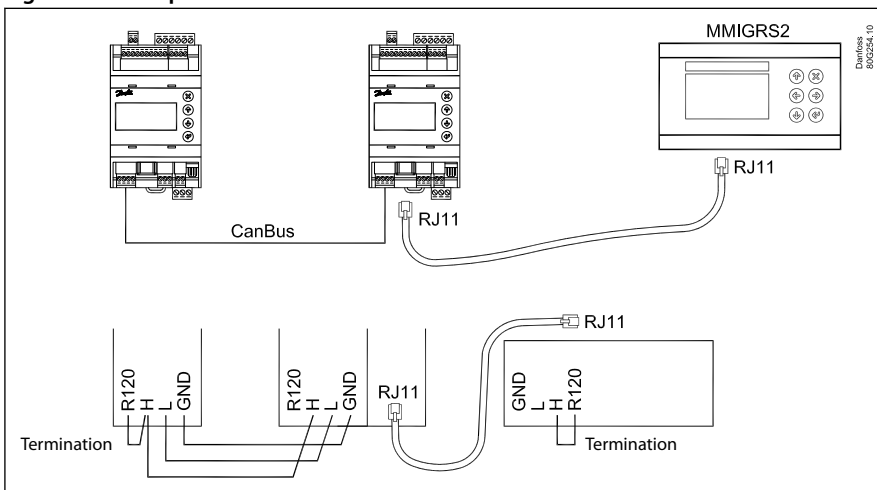
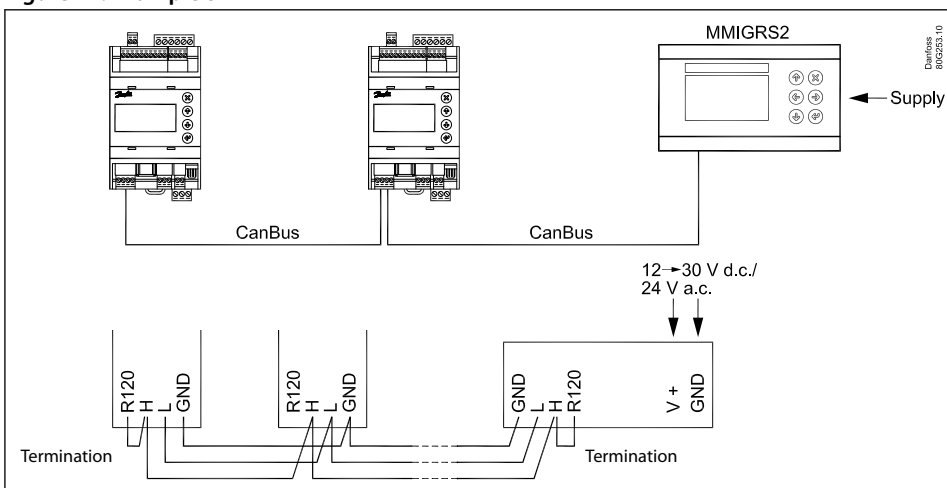

Figure 17: Example 3



ERR31

Alarm on the external display - MMIGRS2

If the communication to the display is not carried out correctly, it will send an “ERR31” error notification. This may be caused by the displayed terminations not being installed, or that there have been interruptions in data communication during the time when the display retrieves the basic information from the controller. Once the

terminations have been inspected, you should then check the software version of the external display. This is done by holding down the Enter key and the X key for 5 seconds, until the Bios menu appears. Next, press the X key and read off the software version in the bottom right corner. The software version must be 1.13 or newer.

Once the display's software version has been checked, check the display's settings as follows:

1. Hold the Enter key and the X key down for 5 seconds, until the Bios menu appears
2. Select the "MCX selection" menu
 - 2.1. Select the "Clear UI" line and press Enter
 - 2.2. Select the "Autodetect" line and press Enter
3. Press the X key to return to the Bios menu
4. Select the "COM selection" menu
 - 4.1. Select the "CAN" line and press Enter
5. Press the X key to return to the Bios menu
6. Select the "Start up mode" menu
 - 6.1. Select the "Remote application" line and press Enter
7. Press the X key to return to the Bios menu
8. Select the "CAN" menu
 - 8.1. Select the "Baudrate" line and then select the "Autobaud" setting and press Enter
 - 8.2. Select the "Node ID" line and set the value to 126 and press Enter
9. Press the X key to return to the Bios menu
10. Select the "Application" menu and press Enter

NOTE:

The display will once again retrieve data from the controller. This process will take about 5 minutes.

Modbus parameters

Table 12: Software version: 1.62.xx

Label	Parameter name	Min value	Max value	Default	Unit	Decimals	Modbus PNU	Locked by main switch	EEPROM	Enumeration
r12	Main switch	0	1	0		0	3001	NO	YES	0 = Off 1 = On
R01	Liquid level setpoint	0	100	50	%	1	3002	NO	YES	
N07	Operation Mode	0	2	0		0	3003	YES	YES	0 = Master 1 = Slave 2 = IO
a02	Lower level limit	0	100	15	%	0	3004	NO	YES	
a01	Upper level limit	0	100	85	%	0	3005	NO	YES	
a07	Level alarm mode	0	1	0		0	3006	NO	YES	0 = Time 1 = Hysteresis
a04	Lower delay	0	999	10	s	0	3007	NO	YES	
a03	Upper delay	0	999	50	s	0	3008	NO	YES	
a06	Lower level hysteresis	0	20	3	%	1	3009	NO	YES	
a05	Upper level hysteresis	0	20	5	%	1	3010	NO	YES	
a08	Function common alarm	0	3	0		0	3011	NO	YES	0 = Not follow 1 = Follow up 2 = Follow low 3 = Follow all
a12	Oscillation detect band	0	100	100	%	0	3012	NO	YES	
a13	Oscillation detect timeout	2	30	20	min	0	3013	NO	YES	
a25	Force pump OFF in stopped mode	0	1	0		0	3117	NO	YES	0 = Off 1 = On
a14	IO Lower level limit	0	100	5	%	0	3101	NO	YES	
a15	IO Upper level limit	0	100	95	%	0	3102	NO	YES	
a16	IO Lower level hysteresis	0	20	3	%	1	3103	NO	YES	
a17	IO Upper level hysteresis	0	20	3	%	1	3104	NO	YES	
a18	IO Lower delay	0	999	10	s	0	3105	NO	YES	
a19	IO Upper delay	0	999	50	s	0	3106	NO	YES	
a20	IO Level limit	0	100	50	%	0	3107	NO	YES	
a21	IO Level delay	0	999	10	s	0	3108	NO	YES	
a22	IO Level hysteresis	0	20	3	%	1	3109	NO	YES	
a23	IO Level action	0	1	0		0	3110	NO	YES	0 = Falling 1 = Rising
N03	Control Method	0	2	2		0	3014	NO	YES	0 = On / off 1 = P-ctrl 2 = PI-ctrl
n35	Regulating principle	0	1	0		0	3015	NO	YES	0 = Low 1 = High

Liquid level controller, Type EKE 347

Label	Parameter name	Min value	Max value	Default	Unit	Decimals	Modbus PNU	Locked by main switch	EEPROM	Enumeration
n04	P-band	5	200	30	%	1	3016	NO	YES	
n05	Integration time Tn	60	600	400	s	0	3017	NO	YES	
n34	Neutral zone	0	25	2	%	1	3018	NO	YES	
N06	Difference	0,5	25	2	%	1	3019	NO	YES	
n13	Period time for AKV / AKVA	3	15	6	s	1	3020	NO	YES	
n33	Minimum OD	0		0	%	0	3021	NO	YES	
n32	Maximum OD	1	100	100	%	0	3022	NO	YES	
o11	Language	0	0	0		0	3023	YES	YES	0 = \$ActiveLanguageList
o17	Output indication	0	1	0		0	3024	NO	YES	0 = Level 1 = OD
K04	Login timeout	1	120	10	min	0	3025	NO	YES	
K06	Backlight timeout	0	120	2	min	0	3026	NO	YES	
o05	Password daily	0	999	100		0	3027	NO	YES	
K02	Password service	0	999	200		0	3028	NO	YES	
K03	Password commission	0	999	300		0	3029	NO	YES	
K05	Contrast	0	100	40	%	0	3030	NO	YES	
K01	Brightness	0	100	80	%	0	3031	NO	YES	
I09	System configuration	0	4	0		0	3032	YES	YES	0 = ICAD+NC 1 = ICAD 2 = AKV/A+NC 3 = AKV/A 4 = NC only
o31	Level signal setup	0	3	0		0	3033	YES	YES	0 = AKS4100 1 = AKS41 2 = Current 3 = Voltage
o32	Voltage at low liquid level	0		0	V	1	3034	NO	YES	
o33	Voltage at high liquid level		10	10	V	1	3035	NO	YES	
I06	Current at low liquid level	0		4	mA	1	3036	NO	YES	
I07	Current at high liquid level		20	20	mA	1	3037	NO	YES	
o34	Valve position setup	0	2	0		0	3038	YES	YES	0 = Not used 1 = Current 2 = Voltage
I02	Voltage at closed valve position	0		0	V	1	3039	NO	YES	
I03	Voltage at open valve position		10	10	V	1	3040	NO	YES	
I04	Current at closed valve position	0		4	mA	1	3041	NO	YES	
I05	Current at open valve position		20	20	mA	1	3042	NO	YES	
I18	Common alarm setup	0	3	1		0	3043	YES	YES	0 = DO4 1 = High Alarm 2 = DO3 3 = Disp only
I08	Multiple valve setup	0	4	0		0	3044	YES	YES	0 = Not used 1 = 2 same cap 2 = 2 dif cap 3 = 3 same cap 4 = 3 dif cap
I13	Multiple valve pattern	0	1	0		0	3045	NO	YES	0 = Parallel 1 = Sequence
I10	Valve A capacity	0	100	50	%	0	3046	YES	YES	
I11	Valve B capacity	0	100	50	%	0	3047	YES	YES	
I12	Valve C capacity	0	100	33	%	0	3048	YES	YES	
I17	ICAD takeover OD	0	100	80	%	0	3052	NO	YES	
I19	IO module setup	0	1	0		0	3091	YES	YES	0 = Not used 1 = Used
G01	CAN ID	1	127	1		0	4032	NO	NO	
G02	Can baudrate	0	5	4		0	4033	NO	NO	0 = 20k 1 = 50k 2 = 125k 3 = 250k 4 = 500k 5 = 1M
G06	Modbus ID	0	120	1		0	3055	NO	YES	
G05	Modbus baudrate	0	8	6		0	3056	NO	YES	0 = 0 1 = 1200 2 = 2400 3 = 4800 4 = 9600 5 = 14400 6 = 19200 7 = 28800 8 = 38400
G08	Modbus mode	0	2	1		0	3057	NO	YES	0 = 8N1 1 = 8E1 2 = 8N2
G07	Modbus mapping	0	1	0		0	3058	NO	YES	0 = Operation 1 = Setup
G09	Valve B CAN ID	1	127	2		0	3088	YES	YES	
G10	Valve C CAN ID	1	127	3		0	3089	YES	YES	
G11	IO Mod. CAN ID	1	127	4		0	3090	YES	YES	

Liquid level controller, Type EKE 347

Label	Parameter name	Min value	Max value	Default	Unit	Decimals	Modbus PNU	Locked by main switch	EEPROM	Enumeration
B01	Controller state	0	6	0		0	4001	YES	NO	0 = Powerup 1 = Stop 2 = Auto 3 = Manual 4 = Slave 5 = IO 6 = Safe
u01	Actual level	0	100	0	%	1	4002	NO	NO	
u02	Actual reference	0	100	0	%	1	4003	YES	NO	
u24	Actual OD	0	100	0	%	1	4004	NO	NO	
u33	Actual valve position	0	100	0	%	1	4005	NO	NO	
u10	Digital input status	0	1	0		0	4006	NO	NO	0 = Off 1 = On
u31	Actual level signal voltage	0	100	0	V	1	4007	NO	NO	
u30	Actual level signal current	0	24	0	mA	1	4008	NO	NO	
B02	Actual position signal voltage	0	100	0	V	1	4009	NO	NO	
u32	Actual position signal current	0	100	0	mA	1	4010	NO	NO	
B03	Actual OD A	0	100	0	%	1	4011	NO	NO	
B04	Actual OD B	0	100	0	%	1	4012	NO	NO	
B05	Actual OD C	0	100	0	%	1	4013	NO	NO	
o18	Manual Mode	0	1	0		0	4014	NO	NO	0 = Off 1 = On
o45	Manual OD	0	100	50	%	1	3059	NO	NO	
B08	Manual low alarm	0	1	0		0	3060	NO	NO	0 = Off 1 = On
B06	Manual high alarm	0	1	0		0	3061	NO	NO	0 = Off 1 = On
B07	Manual common alarm	0	1	0		0	3062	NO	NO	0 = Off 1 = On
B09	Apply defaults	0	1	0		0	3063	YES	NO	0 = None 1 = Factory
B11	Oscillation amplitude	0	100	0	%	1	4028	YES	NO	
B10	Oscillation period	0	3600	0	s	0	4029	YES	NO	

Table 13: Alarms

Label	Alarm name	Modbus PNU	Bit number
A1	Upper level	1901	8
A2	Lower level	1901	9
A92	Oscillation in level signal	1901	10
A96	Valve position	1901	14
A97	Multiple valve capacity	1901	15
E1	Internal error	1901	0
E21	Level signal out of range	1901	1
E22	Valve position signal out of range	1901	2
E96	AKS 4100 error	1901	3
A45	Standby mode	1901	4
A99	Valve B communication	1901	5
A98	Valve C communication	1901	6
A85	Communication to master lost	1901	7
A91	Valve B alarm	1902	8
A90	Valve C alarm	1902	9
A88	Control method conflict	1902	10
A87	Common alarm HW conflict	1902	11
A86	Min / max OD conflict	1902	12
E95	Sensor supply overload	1902	13
E99	DO4 overload	1902	14
E97	Too much current AI3	1902	15
E98	Too much current AI4	1902	0
A89	Multiple valve setup conflict	1902	1
A80	Valve B CAN ID conflict	1902	2
A81	Valve C CAN ID conflict	1902	3
A82	IO module CAN ID conflict	1902	4
A83	IO module communication	1902	5

Dimensions and weights

Figure 18: EKE 347

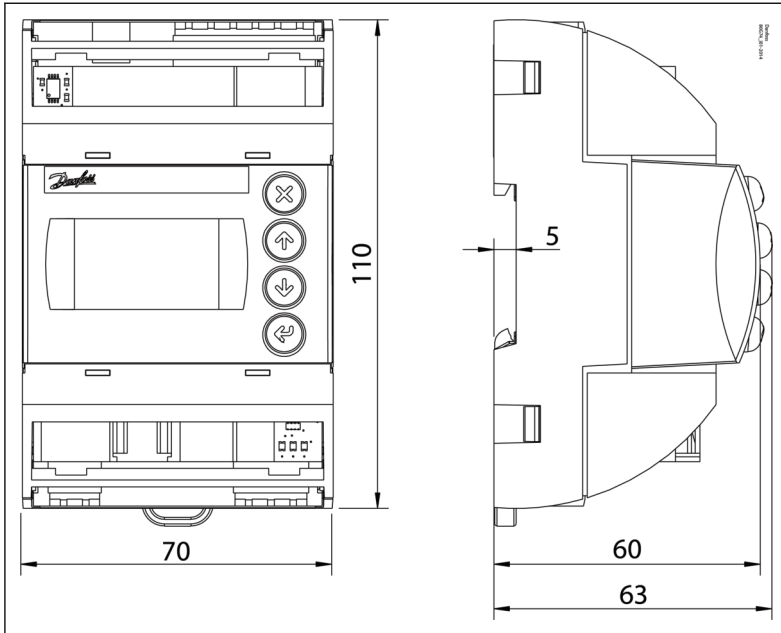

Ordering

Table 14: Ordering

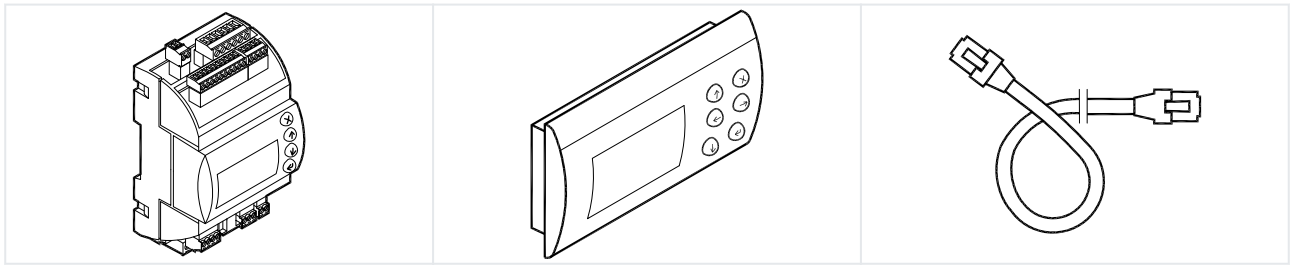

Type	Description	Code No.
EKE 347	Liquid level controller	080G5000
MMIGRS2	Remote display, Panel, S	080G0294
	Wire for display unit, L = 1.5 m, 1 pcs.	080G0075
	Wire for display unit, L = 3 m, 1 pcs.	080G0076
	EKE / EKC accessory for panel mounting	027F0309

Certificates, declarations, and approvals





The list contains all certificates, declarations, and approvals for this product type. Individual code number may have some or all of these approvals, and certain local approvals may not appear on the list.

Some approvals may change over time. You can check the most current status at danfoss.com or contact your local Danfoss representative if you have any questions.

Table 15: Valid Approvals

File name	Document type	Document topic	Approval authority
UA.1O146.D.00070-19	UA Declaration	EMCD/LVD	LLC CDC EURO-TYSK
RU Д-DK.ГA02.B.05523	EAC Declaration	EMC	EAC
080R4002.01	China RoHS	CRN	Danfoss
080R4000.02		CRN	Danfoss

Table 16: Conformity Approvals

    	<p>EU Low Voltage Directive and EMC demands re CE-marking complied with. LVD-tested acc. to EN 60730-1 and EN 60730-2-9 EMC-tested acc. to EN61000-6-3 and EN 61000-6-2 UL file E31024</p>
---	---

Online support

Danfoss offers a wide range of support along with our products, including digital product information, software, mobile apps, and expert guidance. See the possibilities below.

The Danfoss Product Store



The Danfoss Product Store is your one-stop shop for everything product related—no matter where you are in the world or what area of the cooling industry you work in. Get quick access to essential information like product specs, code numbers, technical documentation, certifications, accessories, and more.

Start browsing at store.danfoss.com.

Find technical documentation



Find the technical documentation you need to get your project up and running. Get direct access to our official collection of data sheets, certificates and declarations, manuals and guides, 3D models and drawings, case stories, brochures, and much more.

Start searching now at www.danfoss.com/en/service-and-support/documentation.

Get local information and support



Local Danfoss websites are the main sources for help and information about our company and products. Find product availability, get the latest regional news, or connect with a nearby expert—all in your own language.

Find your local Danfoss website here: www.danfoss.com/en/choose-region.

Danfoss Learning



Danfoss Learning is a free online learning platform. It features courses and materials specifically designed to help engineers, installers, service technicians, and wholesalers better understand the products, applications, industry topics, and trends that will help you do your job better.

Create your Danfoss Learning account for free at www.danfoss.com/en/service-and-support/learning.

Spare Parts



Get access to the Danfoss spare parts and service kit catalog right from your smartphone. The app contains a wide range of components for air conditioning and refrigeration applications, such as valves, strainers, pressure switches, and sensors.

Download the Spare Parts app for free at www.danfoss.com/en/service-and-support/downloads.

Coolselector®2 - find the best components for you HVAC/R system



Coolselector®2 makes it easy for engineers, consultants, and designers to find and order the best components for refrigeration and air conditioning systems. Run calculations based on your operating conditions and then choose the best setup for your system design.

Download Coolselector®2 for free at coolselector.danfoss.com.

Danfoss A/S

Climate Solutions • danfoss.com • +45 7488 2222

Any information, including, but not limited to information on selection of product, its application or use, product design, weight, dimensions, capacity or any other technical data in product manuals, catalogues descriptions, advertisements, etc. and whether made available in writing, orally, electronically, online or via download, shall be considered informative, and is only binding if and to the extent, explicit reference is made in a quotation or order confirmation. Danfoss cannot accept any responsibility for possible errors in catalogues, brochures, videos and other material. Danfoss reserves the right to alter its products without notice. This also applies to products ordered but not delivered provided that such alterations can be made without changes to form, fit or function of the product.

All trademarks in this material are property of Danfoss A/S or Danfoss group companies. Danfoss and the Danfoss logo are trademarks of Danfoss A/S. All rights reserved.