

Instruction

Energy recovery device

MPE 70

Installation instructions

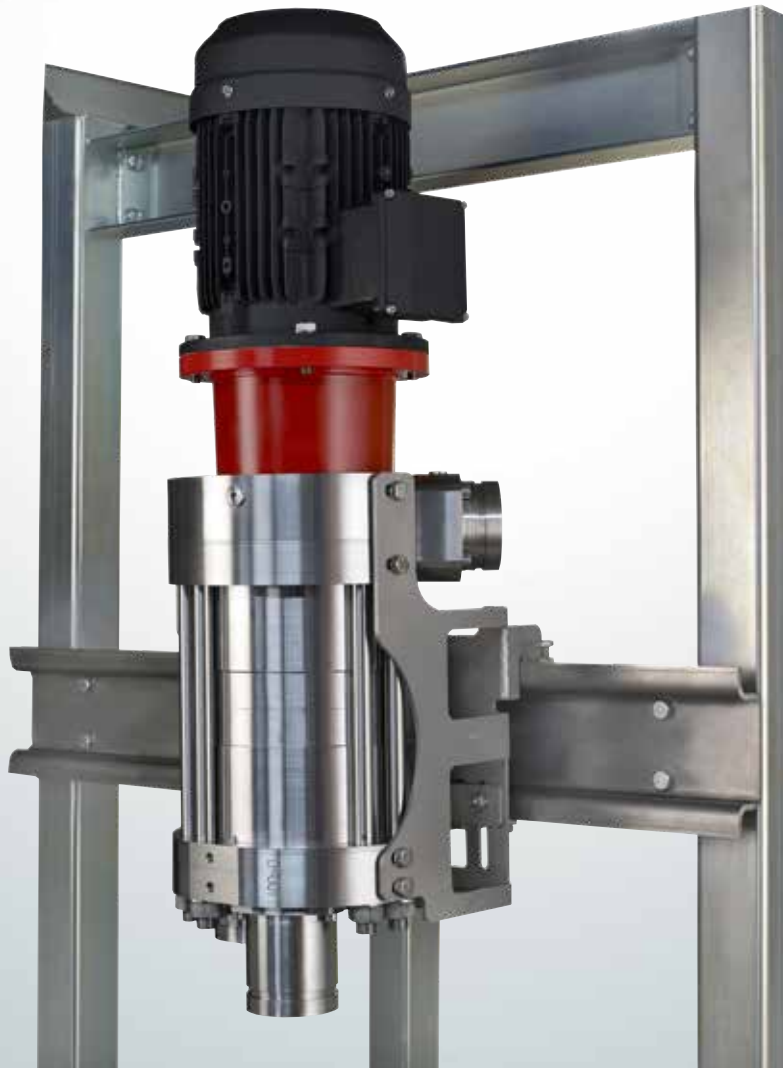

Table of Contents	Contents
1.	Introduction3
1.1	Symbols3
1.2	General3
1.3	Target group3
1.4	MPE 70 tool kit3
2.	Main parts4
3.	Transport and handling4
3.1	Use of lifting eye4
3.2	Lifting unit into vertical position: 5
4.	Assembling MPE 70 to electric motor6
4.1	Installing support feet6
4.2	Bell housing and coupling.6
4.3	Installing coupling and bell housing7
5.	Orientation8
6.	Danfoss bracket and rail system8
6.1	Rail8
6.2	Bracket9
6.3	Adjustment possibilities for the bracket.10
7.	Connecting the MPE 70 to the manifolds.10
7.1	Pipe connections10
7.2	Manifolds10
8.	Installing and alignment11
8.1	Installing the MPE 70 on the rail11
8.2	Alignment of the units on the rail11
9.	Removing transit screw12
10.	Grounding12



1.4 MPE 70 tool kit

Some of the tools are required for the installation of the MPE 70.



1. Introduction

1.1 Symbols



Indicates a situation which will or could result in personal injury and/or damage to the pump.



Indicates a situation which will or could result in damage to the pump and its function .

1.2 General

This document covers the instructions for installation of the MPE 70.



All personnel who are responsible for the installation of the MPE 70 unit must read and fully understand these instructions before:

- Transporting of the MPE unit.
- Lifting the unit.
- Installing the MPE unit on a frame.
- Connecting the MPE unit to the fluid system

1.3 Target group

This manual is intended for use by personnel with qualified training and experience in installing of a Sea Water Reverse Osmosis (SWRO) or Brackish Water Reverse Osmosis (BWRO) system.

Tool set 180F4177:

- Lifting eye M6
- Lifting eye M8
- 2 x Lifting eye M12
- Torque wrench 4-20 Nm
- Torque wrench 20-100 Nm
- Torque wrench 60-340 Nm
- Extension 3/8" , length 250 mm
- 2 x Screwdriver 5,5 x 1 mm
- Screwdriver small
- Nylon Hammer
- Wrench 10 mm
- Wrench 30mm
- Hex socket 6 mm, 3/8"
- Hex Socket 10 mm, 3/8"
- Hex Socket 30 mm
- Socket 17mm 3/8
- Allen key 2.5mm
- Allen hex head 5mm (3/8)
- Allen hex head 8mm (3/8)
- 2 x Screw M6x60
- 2 x Washer Ø12.0/Ø6.4
- 2 x Nut M6
- 2 x Screw M8x50
- Tool for backup ring
- 2 x Tool for valve plate
- Tool for shaft seal
- Calibration tool
- 4 x Feet
- 8 x M10 x25 (feet)
- 8 x Washers Ø12.6 for feet

To prevent cold welding, Danfoss recommend to use thread lubricant for all screw threads for installing the MPE 70 (here after only referred to as lubricate) and first tighten the screws by hand.

1.5 Additional technical document

For below Design guide, please contact Danfoss High Pressure Pumps.

Document name	Content
Design guide: 180R9367 Pipe connection	Describes how to make hard piping with Victaulic® clamps

2. Main parts

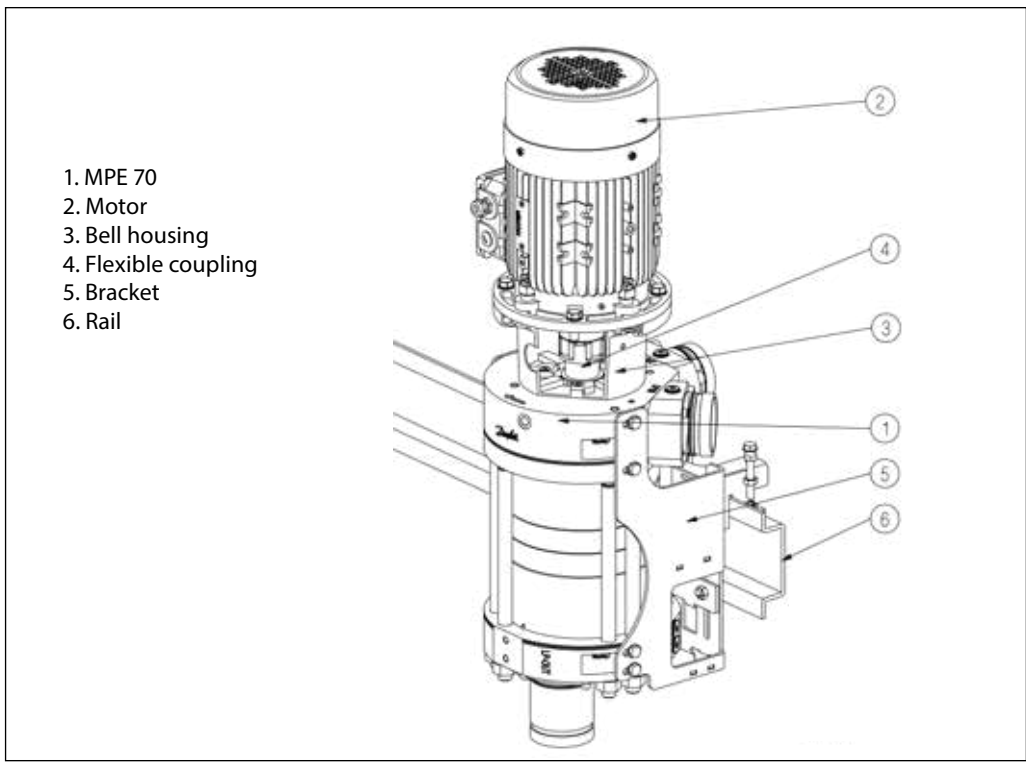

- 1. MPE 70
- 2. Motor
- 3. Bell housing
- 4. Flexible coupling
- 5. Bracket
- 6. Rail

3. Transport and handling

Personnel involved in lifting and transportation of the equipment must be trained in proper handling and safety procedures. Observe the local regulations regarding lifting. Use suitable, permitted lifting equipment. Be aware of individuals located in the operation area while lifting the component.

The weight of the MPE 70 including electric motor can be found in the datasheet. Use suitable lifting devices, e.g. an overhead crane or forklift.

When lifting the unit use the lifting eyes and jacking beam (not supplied by Danfoss). Make sure that the load is balanced before attempting the lift.

Do not use connections/nozzles for lifting. Do not use one sling.

3.1 Use of lifting eye

The M12 lifting eyes supplied with the MPE 70 are to be used for straight lift only.

For inclined lift use the lifting eyes from the tool set.

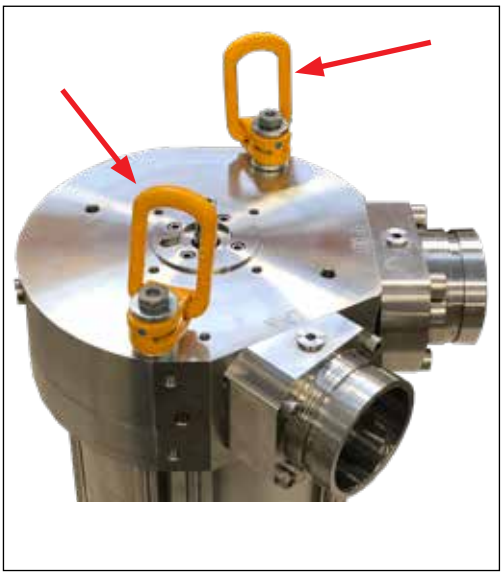
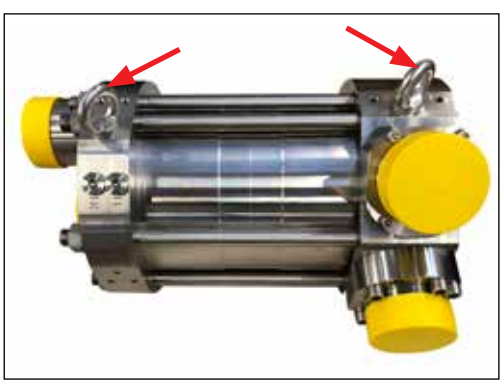

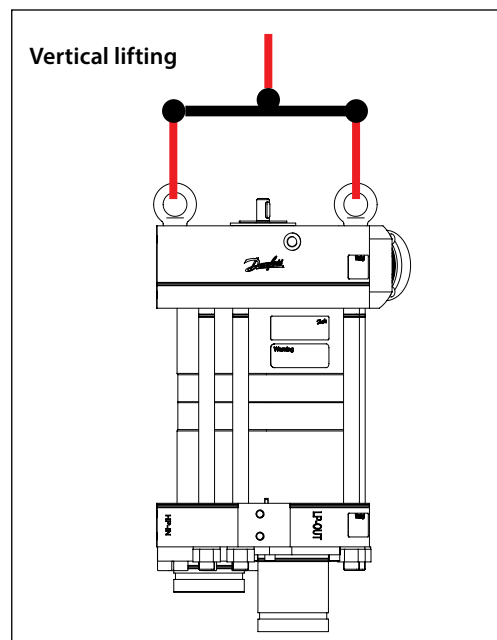
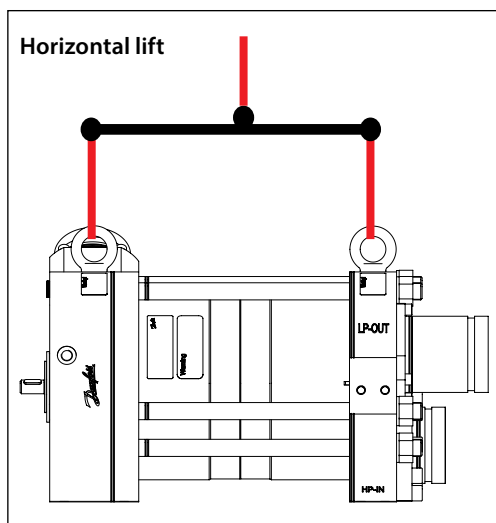

To protect the connectors during lifting place the MPE 70 with plastic caps on the connectors on a wooden board.

Keep plastic caps on until MPE 70 is installed to the base frame.

3.2 Lifting unit into vertical position:

Use jacking beam (not supplied by Danfoss) and two slings connected to the two lifting eyes for inclined lift from the tool kit installed to the thread holes at the shaft end of MPE 70. To prevent damaging the connectors balance the unit by pressing the motor down until the unit is in vertical position.

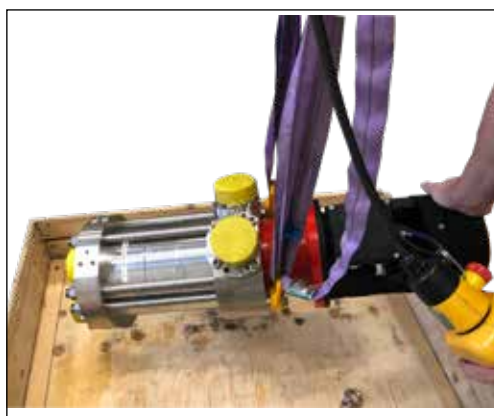

4. Assembling MPE 70 to electric motor

4.1 Installing support feet

The motor can be installed either before or after the MPE unit is placed on the rail. If it is not installed on the rail, the MPE 70 is positioned vertically by installing the four support feet from the tool set.

Tighten the bolts with 30 Nm.



4.2 Bell housing and coupling

The MPE 70 is connected to the electric motor by the bell housing and a flexible coupling. See section 2. Main parts

The bell housing and coupling can be supplied by Danfoss.

For other suppliers of the bell housing:

The MPE 70 shaft and motor shaft should be aligned within 0.2 mm / 0.008 in.

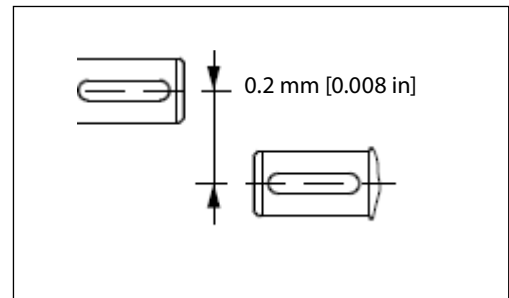

4.3 Installing coupling and bell housing

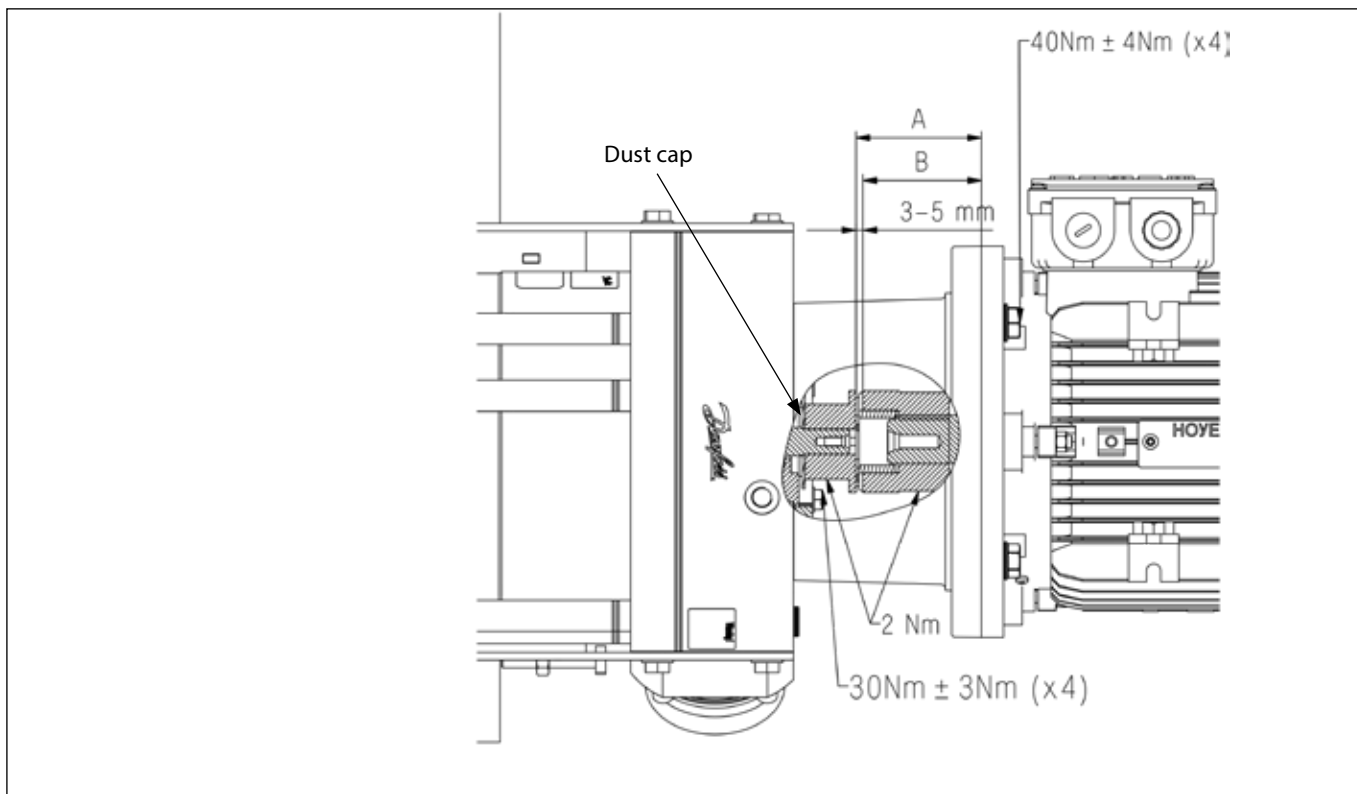

1. Check that the dust cap is placed on the MPE 70 shaft. Mount the coupling for the MPE 70 on the shaft all the way down to the dust cap and press down for tight contact. Tighten the set screw according to specification.
2. Mount the bell housing on MPE 70. Secure nuts with the right torque.
3. Measure the longest distance "A" from top of bell housing to the bottom of coupling claw.
4. Mount the coupling on motor shaft.
5. Measure from motor flange to the top of the coupling. That measurement "B" shall be 3 - 5 mm (0.12 - 0.2 inch) shorter the measurement "A".
6. Verify the measurement and secure the coupling with the right torque on the set screw. Mount the elastic gear ring and mount the bell housing/MPE 70 on the motor. After mounting verify the distance between the coupling hubs to be 3 - 5 mm (0.12 - 0.2 inch) axial. The check can be done through the inspection hole of the bell housing.
7. Secure flange bolts with the right torque.



Note:
Any axial and radial load on the shaft must be avoided.

If alternative mounting is required, please contact Danfoss for further information

Instruction | MPE 70 energy recovery device

- 5. Orientation**
- The MPE 70 is built for vertical installation. The electric motor must be placed above the MPE 70. The MPE 70 is connected to the electric motor by the bell housing. The motor can be rotated in any direction for easy access to the terminal box

- 6. Danfoss bracket and rail system**
- Danfoss recommends using the MPE 70 together with mounting bracket 180Z4107 and rail 180Z4108, see section 2 Main parts.



The Danfoss bracket and rail system is to be used only with hard piping to the MPE 70 connections.

Although the mounting rail is of sturdy design, it can flex or bend when it is installed bolted to a frame. Therefore, the rail should always be installed to a rigid steel frame.



An unlocked bolt can result in personal injury and/or damage to the MPE 70.

6.1 Rail

The rail must be bolted to a frame so the rail is supported for every one meter. The rail is supplied without holes for the bolts.

Danfoss does not supply the bolts for mounting the rail to the frame. Danfoss recommends M12 bolts A4-80. Bolt tightening torque acc. to recommendation from the bolt supplier. Make sure that the bolts are properly locked and will stay locked over time.



The rail must be supported on both sides of the MPE 70

Recommended hole pattern for rail

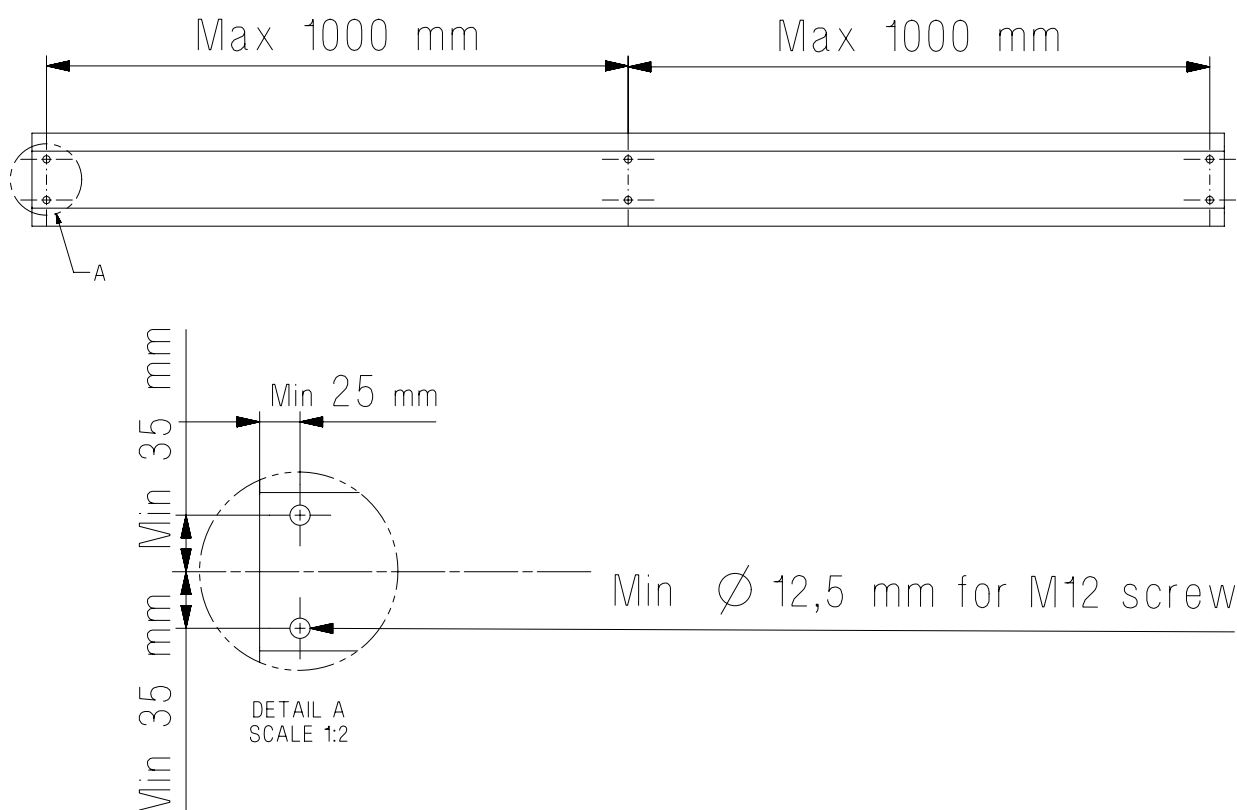

Spacing of MPE 70 on the rail
 Danfoss recommends a minimum distance of 400 mm between the MPE's.

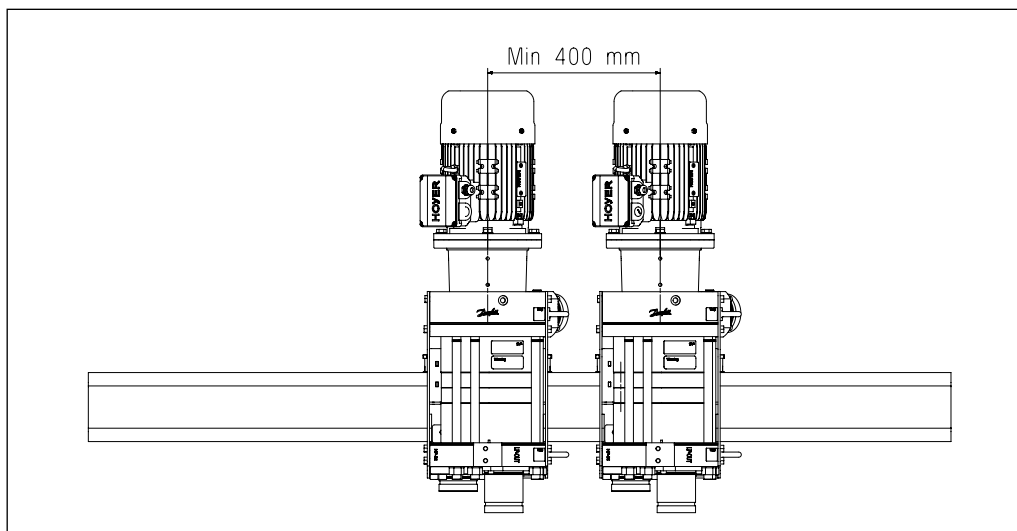

6.2 Bracket

The bracket supplied by Danfoss consists of:

1. Main bracket
2. Bottom piece - loosely mounted to the bracket
3. 8 x M10 bolts – in plastic bag
4. 2 x height adjustment screws mounted to the bracket
5. 2 x safety screws – in plastic bag
6. 2 x M10 nuts
7. 10 x washers – in plastic bag

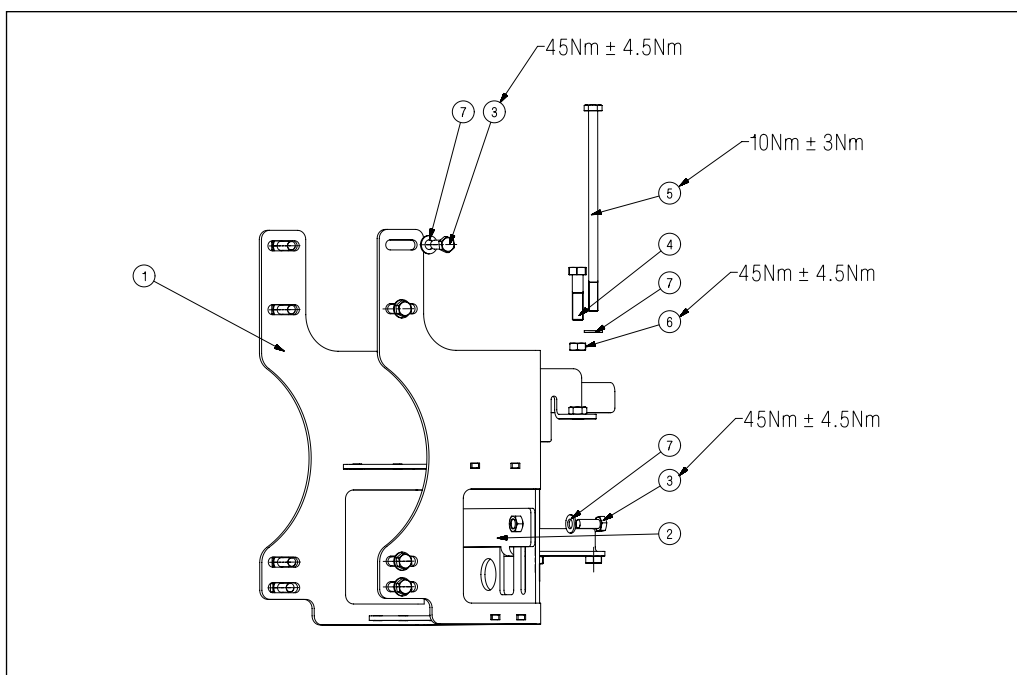

6.3 Adjustment possibilities for the bracket The Danfoss bracket allows for adjustment in X-, Y-, Z- direction during the alignment proces.

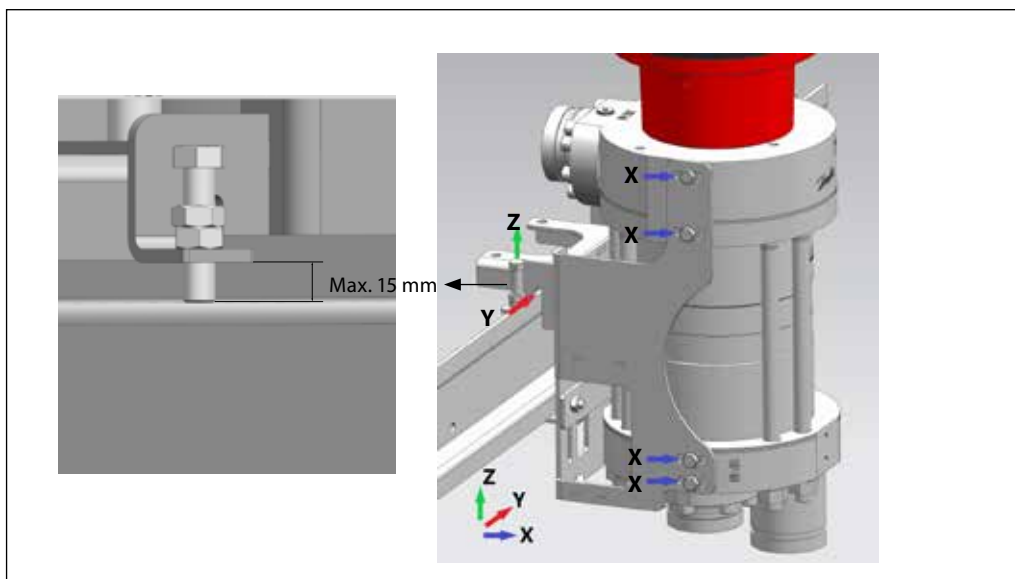

7. Connecting the MPE 70 to the manifolds

7.1 Pipe connections

The MPE connection ports are designed for hard piping. Danfoss recommends following the Guideline 180R9367 - Pipe connection. This guideline is based on the use of Victaulic® Style 77 Flexible Coupling. Spool pieces must be manufactured according to the "Victaulic® (OGS) cut groove specifications" or similar. To allow for inaccuracies in the manifolds and to ensure an easy installation we recommend mounting a spool piece with a minimum length of 80 mm on the HP-out connection.

7.2 Manifolds

The manifolds must have enough support to prevent them from moving when getting pressurized. The manifolds must be clean inside before connecting them to the MPE 70.

Instruction | MPE 70 energy recovery device

8. Installing and alignment

The bracket is attached to the MPE 70 unit by four x M10 bolts each side, positioned in the center of the sleeve, for later adjustments. Tighten the bolts - see section 6.2. Lift the unit with motor and bracket using suitable crane or winch. We recommend the spool piece for HP out to be installed to the manifold before installing the MPE 70 unit on the rail.

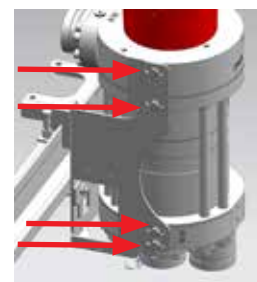

8.1 Installing the MPE 70 on the rail

Place the unit on the rail. Both sides of the bracket must grip the rail before lowering the unit.

Slide the bottom piece of the bracket up to grip the rail. Allow for some play. Hand tighten the screws on the bottom bracket to allow for adjustment during alignment



8.2 Alignment of the units on the rail

The rail and MPE 70 must be aligned with the manifolds to avoid stress or bending.



Misalignment may cause stress and/or damage to the Victaulic connections.

The HPout connector is aligned first. Then the spool piece for the HPin side can be manufactured to length. The LP piping is mounted last. Start with aligning the first unit on the rail, then the last unit and then the units in between until all the units have been aligned.

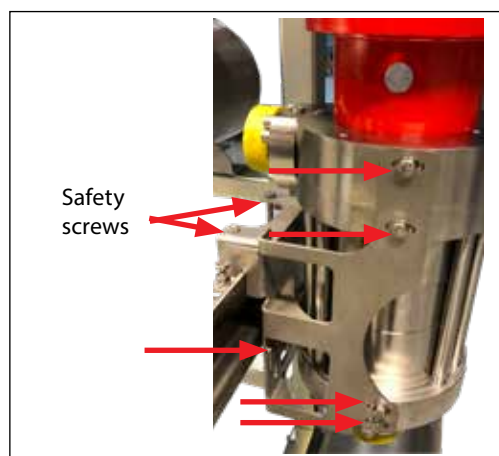

Do not pressurize the units without proper alignment.



After aligning secure the unit on the rail by tightening all the screws incl. **the safety screws** with the specified torque, see section 6.2.

9. Removing transit screw

When the installation is done, the transit screws at the center of the port flange must be removed and replaced by the plug supplied in the plastic bag with the unit.



Note: During longer period of transportation it is recommended to install the transit screw.

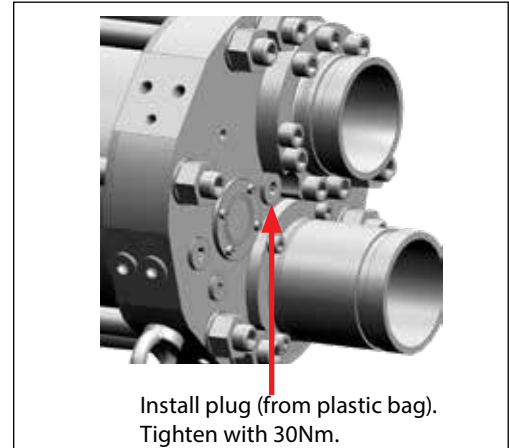
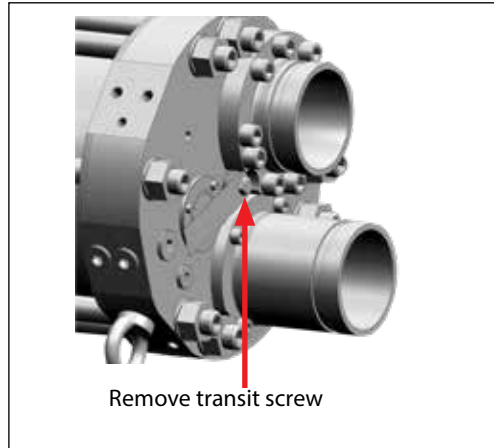

10. Grounding

To limit/prevent galvanic corrosion, MPE 70 skid should be properly grounded. All parts in the system must be electrical potential equalized to a single reference point (grounding point). It is recommended that the electrical resistance in the grounding cable is equal to or below 0.25 Ohm towards the grounding point.

Use one of the M12 thread holes in the motor flange of the MPE 70 for grounding

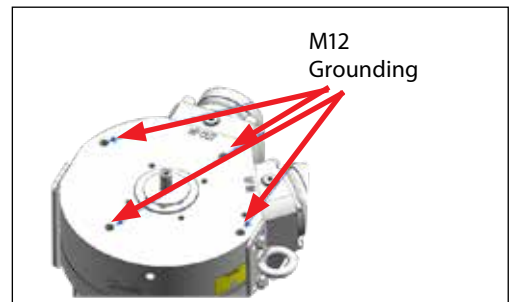

Danfoss A/S
High Pressure Pumps
Nordborgvej 81
DK-6430 Nordborg
Denmark

Danfoss can accept no responsibility for possible errors in catalogues, brochures and other printed material. Danfoss reserves the right to alter its products without notice. This also applies to products already on order provided that such alterations can be made without subsequential changes being necessary in specifications already agreed. All trademarks in this material are property of the respective companies. Danfoss and the Danfoss logotype are trademarks of Danfoss A/S. All rights reserved.