



Data Sheet

X-tra™ Collection for Designer Radiators and Bathroom Towel Rails

Application



The new X-tra Collection is a TRV specially designed for towel rails and designer radiators. Its new and innovative self-sealing ½" valve to radiator connection makes for a seamless, elegant and easy installation.

The towel rails valve set includes a matching lockshield valve with drain-off function. The valves and sensors are available in white, chrome and Inox versions matching the most common rail radiators.

The valve set provides the perfect finishing touch for towel rails. The aesthetically pleasing and compact design allows the sensor to be mounted underneath the towel rail, parallel with the wall, avoiding the risk of accidentally knocking the sensor.

Small to medium-sized convectors with valves matching in colour or in contrast colours, is also an interesting application for this series of valves.

Two sensor types using different regulating concepts are available:

- Type RAX, which is a room temperature sensor.
- Type RTX - a return temperature limiter, meaning that it senses and regulates the return flow in the radiator rather than the air temperature. Used on a towel rail, and set 5 -10 degrees above room temperature, the RTX sensor will keep the radiator warm - ensuring dry towels.

The visual appearance of the two sensors are identical except for the scale numbers. RAX has I-II-III-IV-V and RTX has numbers 1-2-3-4-5.



Ordering
Valves

Type	Description	Chrome	RAL 9016	Inox
	RA-URX, right side mounted valve for return flow	013G4030	013G4050	013G4060
	RA-URX, left side mounted valve for return flow	013G4031	013G4051	013G4061
	RLV-X, right side mounted lockshield valve	013G4032	013G4052	013G4062
	RLV-X, left side mounted lockshield valve	013G4033	013G4053	013G4063

Sensors

	RAX, thermostatic sensor element	013G6170	013G6070	013G6171
	RTX, return temperature limiter	013G6190	013G6090	013G6191

Set Packs

	Set: right-mounted RAX sensor, thermostat, valve and lockshield valve	013G4003	013G4007	013G4009
	Set: left-mounted RAX sensor, thermostat, valve and lockshield valve	013G4004	013G4008	013G4010
	Set: right-mounted RTX sensor, thermostat, valve and lockshield valve	013G4132	013G4136	013G4138
	Set with left-mounted RTX sensor, thermostat, valve and lockshield valve	013G4133	013G4137	013G4139

Technical Data

Type	Design	Connection		k _v -values [m ³ /h] with RAX sensor at setting ¹⁾								
		Rad.	Sys.	1	2	3	4	5	6	7	N	N (k _{vs})
RA-URX	Left mounted angle valve Right mounted angle valve	R ½	R ½	0.03	0.06	0.13	0.17	0.23	0.27	0.29	0.34	0.44

Type	Design	Connection		k _v -values [m ³ /h] with RAX sensor at setting ¹⁾						k _{vs}
		Rad.	Sys.	0.25	0.50	0.75	1	1.5	2	
RLV-X	Left mounted angle valve Right mounted angle valve	R ½	R ½	0.18	0.36	0.47	0.52	0.58	0.58	0.60

Max. work. pressure: 10 bar, max. diff. pressure²⁾: 0,6 bar, test pressure 16 bar, max. flow temp.: 120 °C

¹⁾ The k_v-value indicates the water flow (Q) in m³/h at a pressure drop (Δp) across the valve of 1 bar;

$k_v = \frac{Q}{\sqrt{\Delta p}}$. At setting N the k_v-value is stated according to EN 215, at X_p = 2K i.e. the valve is closed at 2°C higher room temperature. At lower settings the X_p value is reduced to 0.5K of the setting value 1. The k_{vs}-value states the flow Q at a maximum lift, i.e. at fully open valve at setting N.

²⁾ The maximum differential pressure specified is the maximum pressure at which the valves give satisfactory regulation. As with any device which imposes a pressure drop in the system, noise may occur under certain flow/pressure conditions. The differential pressure can be reduced by the use of the Danfoss differential pressure regulators.

Capacities

RA-URX 15

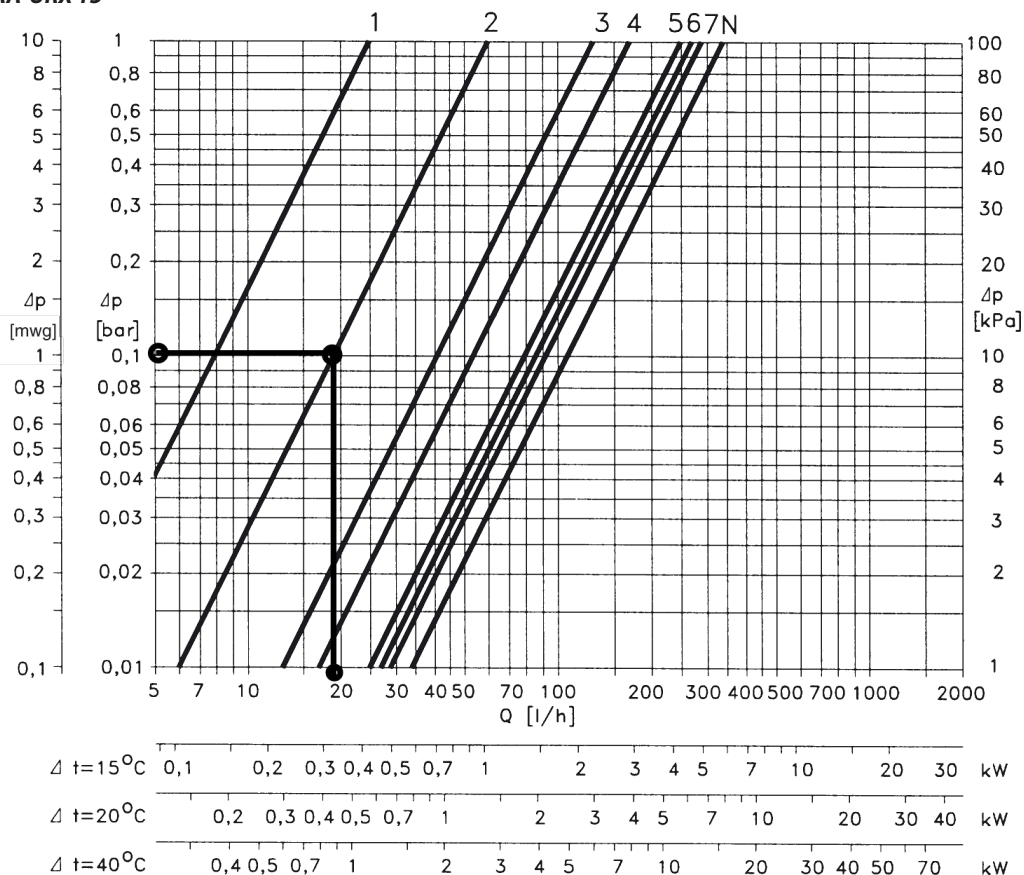

Capacity with RA-URX, RLV-X and RAX sensor at a P-band between 0.5 K and 2 K.

Sizing example

Required heat:	0.65 kW
Cooling across radiator:	30 °C
Flow through radiator:	
$Q = \frac{0.65}{30 \times 1.16} = 0.18 \text{ m}^3/\text{h} = 0.005 \text{ l/s}$	
Pressure drop across valve:	Δp = 1 mwg
Valve setting:	"2"

Alternatively the setting can be read directly in the table "Ordering and technical data":

$$k_v = \frac{Q \text{ (m}^3/\text{h)}}{\sqrt{\Delta p \text{ (bar)}}$$

Valve presetting when using RTX sensor

Due to the function of the RTX sensor its influence on the hydraulic balance of the heating system is very limited. Consequently it is seldom required to adjust the kv-setting of the valve from the factory setting "N".

The table shows the reduced flow in m³/h when applying different kv_v-settings:

Valve pre-setting	2K	5K
1	0.03	0.03
2	0.07	0.07
3	0.12	0.13
4	0.16	0.18
5	0.19	0.24
6	0.21	0.27
7	0.22	0.29
N	0.23	0.33

Design

RA-URX - with gland seal for RAX

1. Protective cap
2. Gland seal
3. Pressure pin
4. Return spring
5. Setting cylinder
6. Valve body
7. Allen screw
8. Self-sealing gland

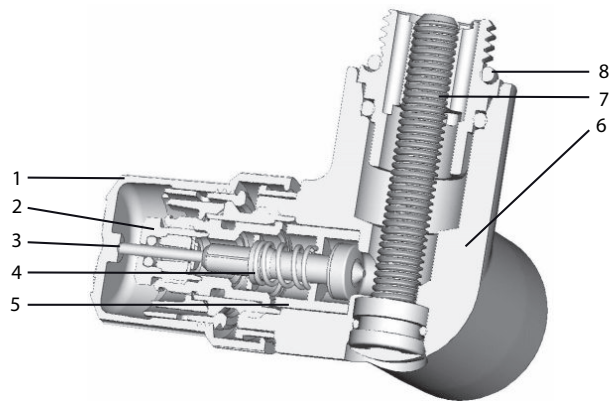

RA-URX - with gland seal for RTX

1. Protective cap
2. Gland seal
3. Pressure pin
4. Return spring
5. Setting cylinder
6. Valve body
7. Allen screw
8. Self-sealing gland

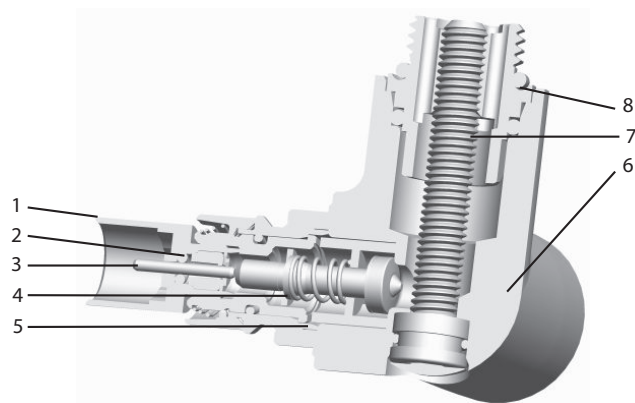

RLV-X

1. Self-sealing gland
2. Allen screw
3. Valve body
4. Shut-off facility
5. Cylindric guide
6. Cover cap

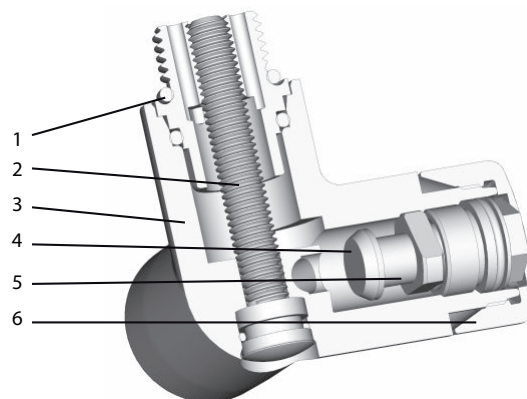

The valve assembly features valve body and a self-sealing gland pre-mounted with 2 O-rings - one for sealing against the radiator and one for sealing in the valve housing.

The Allen-screw features an O-ring seal to ensure a tight seal against the valve body.

In situations where radiator in- and outlets are not suitable for O-ring seal, conventional sealing material is used.

Materials in contact with water

Setting cylinder	PPS
Spindle	Ms, resistant against disinfection
O-rings	EPDM
Valve cone	NBR
Pressure pin	Chrome-plated steel
Valve body	Ms 58

Fittings, Spare Parts and Accessories

Compression fittings	Code no.	Compression fittings	Code no.
Steel/copper, 8 mm	013G4108	ALUPEX, 12 x 2 mm	013G4172
Steel/copper, 10 mm	013G4110	ALUPEX, 14 x 2 mm	013G4174
Steel/copper, 12 mm	013G4112	ALUPEX, 16 x 2 mm	013G4176
Steel/copper, 14 mm	013G4114	PEX, 12 x 1.1 mm	013G4143
Steel/copper, 15 mm	013G4115	PEX, 12 x 2 mm	013G4142
Steel/copper, 16 mm	013G4116	PEX, 14 x 2 mm	013G4144
		PEX, 15 x 2.5 mm	013G4147
		PEX, 16 x 2 mm	013G4146

Spare parts	Code no.
Gland seal for RA-URX valve with RAX sensor	013G0290

Accessories	Code no.
Drain and fill tap	003L0152

Presetting

Danfoss pre-settable valve bodies incorporate easy setting adjustment rings with clearly engraved setting markers scaled from 1 - 7 and N. Setting values can be set quickly and precisely, without the need for tools, as follows:

- Remove protective cap or sensor element
- Lift setting ring
- Turn anti-clockwise to the desired engraved setting value
- Allow setting ring to spring back into position

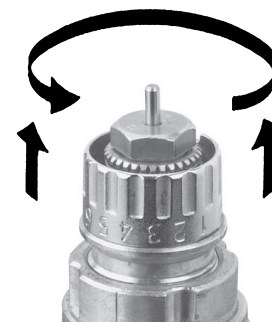

The preset level can be selected in 0.5 increments between 1 and 7 (see chart on page 3 for flow rates). At setting N the valve is fully open (flushing option).

Temperature Setting

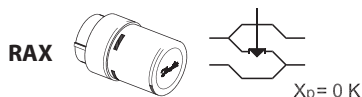

	10	14	18	22	26	30 °C
0	*	I	II	III	IIII	>I
	8	12	16	20	24	28 °C

* = Frost protection

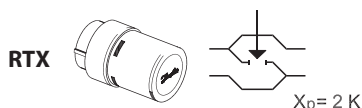

0	I	2	3	4	>I
10	20	30	40	50	60 °C

Closing temperature

Installation

Valve and lockshield valve are matching in designs.

The self-sealing gland is mounted in radiator inlet and outlet using a 17 mm hexagonal key.

The yellow valve cap can temporarily be used to open and shut the valve.

The lockshield valve features shut-off and draining facility.

All O-rings are of the EPDM-type, which means no mineral oils or grease are to be used.

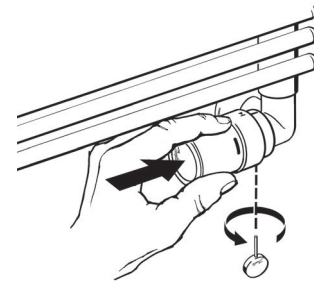
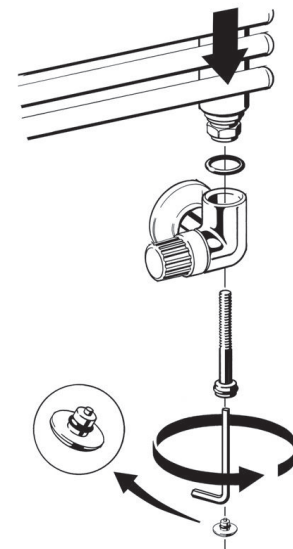

Shut-off, Filling and Draining

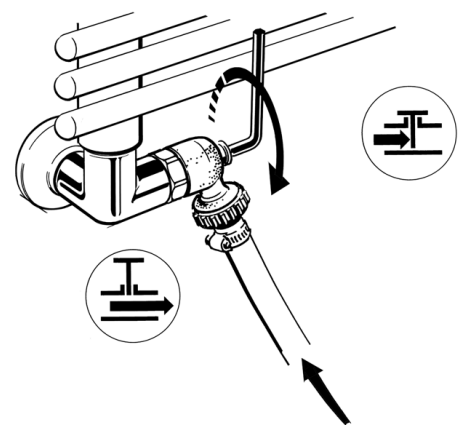
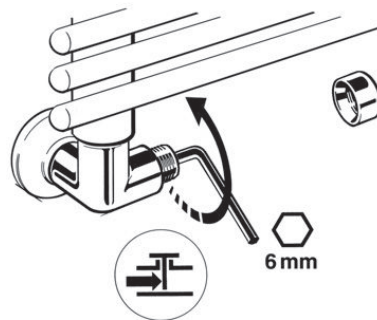

Dimensions

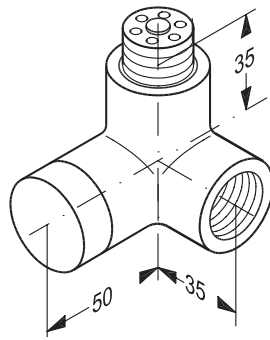

RLV-X lockshield valve

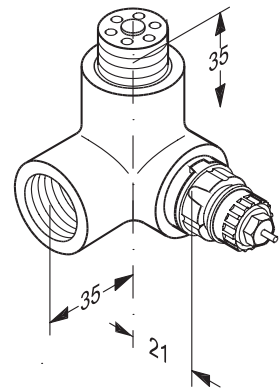

RA-URX return valve

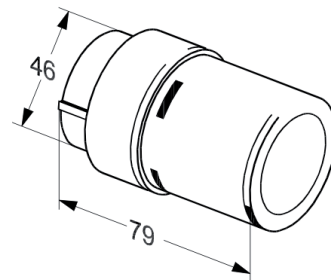

RAX and RTX thermostatic sensors

Danfoss A/S
Heating Solutions
Haarupvaenget 11
8600 Silkeborg
Denmark
Phone: +45 7488 8000
Fax: +45 7488 8100
Email: heating.solutions@danfoss.com
www.heating.danfoss.com

Danfoss can accept no responsibility for possible errors in catalogues, brochures and other printed material. Danfoss reserves the right to alter its products without notice. This also applies to products already on order provided that such alterations can be made without subsequential changes being necessary in specifications already agreed. All trademarks in this material are property of the respective companies. Danfoss and the Danfoss logotype are trademarks of Danfoss A/S. All rights reserved.
