



Data sheet

Pressure independent control valve with integrated flow limiter AFQMP 2 - return and flow mounting, adjustable setting

Description



virtus.danfoss.com



AFQMP 2 is a self-acting flow controller with integrated control valve and with pressure actuator with adjustable spring, developed for the use in district heating / cooling systems. The controller prevents flow to exceed set max flow. Pressure actuator with adjustable spring enables adjustment of differential pressure over the control cone from 0.1 to 1 bar. Increased flows can be provided. In a combination with electrical actuators AMV(E) and ECL electronic controllers the flow and temperature can be controlled to achieve highest energy savings.

AFQMP 2 has a control valve with adjustable flow limiter, connection neck for electrical actuator and a pressure actuator with one control diaphragm.

Controllers are used together with Danfoss electrical actuators:

- AFQMP 2 PN 16/25/40 DN 65-250
 - AMV(E) 655 without spring return function and with manual operation;
 - AMV(E) 658 SD²⁾ spring return function and manual operation;
 - AMV(E) 659 SD¹⁾ spring return function;
 - AMV(E) 55
- AFQMP 2 PN 16/25/40 DN 65-125
 - AMV(E) 56

¹⁾ DIN approved (according to EN 1457)

²⁾ not DIN approved

Together with Danfoss intelligent electrical actuator AMEi 6 intelligent optimization functions are available:

- iSET-intelligent substation efficiency optimization
- iNET-intelligent pump optimization

Main data:

- DN 65-250
- k_{vs} 60-800 m³/h
- Flow range 4.2-630 m³/h
- PN 16, 25, 40
- Differential pressure over the flow control cone Δp_{cv} :
0.1-1 bar (adjustable by the spring)
- Temperature:
 - Circulation water / glycolic water up to 30 %:
2 ... 150°C
- Connections: Flange
- AFQMP 2 combined with AMV(E) 659 SD have been DIN approved according to EN 14597.

Ordering

Example:
Flow controller with integrated control valve for flow rate, DN 65, k_{vs} 60, PN 16, T_{max} 150 °C, flange

- 1x AFQMP 2 DN 65 controller
Code No.: **003G5560**

The controller will be delivered completely assembled, inclusive impulse tubes between valve and actuator. Electrical actuator AMV(E) must be ordered separately.

AFQMP 2 Controller

Picture	DN	Q_{max}	PN	Connection	Code No.
		$\Delta p_{cv} = 0.1-1 \text{ bar}$			
	65	27-61	16	Flange EN 1092-1	003G5560
	80	40-100			003G5561
	100	60-138			003G5562
	125	100-230			003G5563
	150	130-290			003G5564
	200	180-450			003G5565
	250	280-630			003G5566
	65	27-61	25		003G5570
	80	40-100			003G5571
	100	60-138			003G5572
	125	100-230			003G5573
	150	130-290			003G5574
	200	180-450			003G5575
	250	280-630			003G5576
	65	27-61	40		003G5580
	80	40-100			003G5581
	100	60-138			003G5582
	125	100-230			003G5583
	150	130-290			003G5584
	200	180-450			003G5585
	250	280-630			003G5586

Accessories

Picture	Type designation	Description	Code No.
	AMEi 6 iSET el. actuator 230 V	Intelligent Δp actuator with iSET function	082G4300
	AMEi 6 iSET el. actuator 24 V		082G4301
	AMEi 6 iNET el. actuator 230 V	Intelligent Δp actuator with iNET function	082G4302
	AMEi 6 iNET el. actuator 24 V		082G4303

Service kits

Picture	Type	k_{vs} (m ³ /h)	PN	DN	Code No.
	Pressure control insert VFG/Q 221	60	16/25/40	65	003G1807
		80		80	003G1808
		160		100	003G1809
		250		125	003G1810
		380		150	003G1811
		650		200	003G1812
		800		250	003G1813
	Flow stuffing box VFG/Q 22(1)			65-125	003G1720
				150-250	003G1721
	Pressure stuffing box VFG/Q 22(1)			65-125	003G1730
				150-250	003G1731

AFQMP 2 Actuator

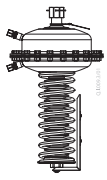
Picture	Actuator size (cm ²)		Δp setting range (bar)	for DN	Code No.	
					PN 16	PN 40
	160	blue	0.1-1	65-125	003G5612	003G5622
	320	orange		150-250	003G5610	003G5620

Technical data

AFQMP 2 valve

Nominal diameter		DN	65	80	100	125	150	200	250
k _{vs} value		m ³ /h	60	80	160	250	380	650	800
Range of max. flow settings	Q _{max}	Δp _{CV} ¹⁾ = 0.1 bar	27	40	60	100	130	180	280
		Δp _{CV} ¹⁾ = 1 bar	61	100	138	230	290	450	630
Stroke		mm	12	19	23	28	32		
Control valve authority		1 (100 %) in the range of flow setting							
Control characteristic		linear-split							
Cavitation factor z			0.65	0.55	0.4	0.4	0.4	0.4	0.3
Leakage acc. to standard IEC 534		% of k _{vs}	≤ 0.01						
Nominal pressure		PN	16, 25, 40						
Min. differential pressure		bar	see remark ²⁾						
Max. differential pressure PN 16			16	16	15	15	12	10	10
Max. differential pressure PN 25/40			20	20					
Pressure relievement system		Chamber relieved							
Media		Circulation water / Glycolic water up to 30 %							
Media pH		Min.7, max.10							
Media temperature		°C	2 ... 150						
Connections		Flange							
Materials									
Valve body		PN 16	Grey cast iron EN-GJL-250 (GG-25)						
		PN 25	Ductile iron EN-GJS-400-18-LT (GGG-40.3)						
		PN 40	Cast steel GP240GH (GS-C 25)						
Valve seat DP, CV		Stainless steel, mat. No. 1.4021							
Valve cone DP, CV		Stainless steel, mat. No. 1.4021							
Sealing DP, CV		EPDM							

¹⁾ DP-diff. pressure over the pressure control cone, CV-diff. pressure over the flow control cone, Δp_{AFQMP} - diff. pressure over AFQMP 2 valve

²⁾ Required differential pressure for desired flow Q → Δp_{AFQMP} = $\left(\frac{Q}{k_{vs}}\right)^2 + \Delta p_{CV}$, Δp_{CV} can be set between 0.1 - 1 bar

AFQMP 2 actuator

For valve	DN	65	80	100	125	150	200	250
Actuator size	cm ²	160			320			
Max. operational pressure		16 or 40						
Differential pressure over the flow control cone Δp_{cv}	bar	0.1-1 (adjustable)						
Materials								
Housing		Steel, mat. No. 1.0345, zinc plated						
Diaphragm		EPDM (Rolling; fibre enforced)						
Impulse tube		Stainless steel tube $\varnothing 10 \times 0.8$ mm						

Range of max. flow settings

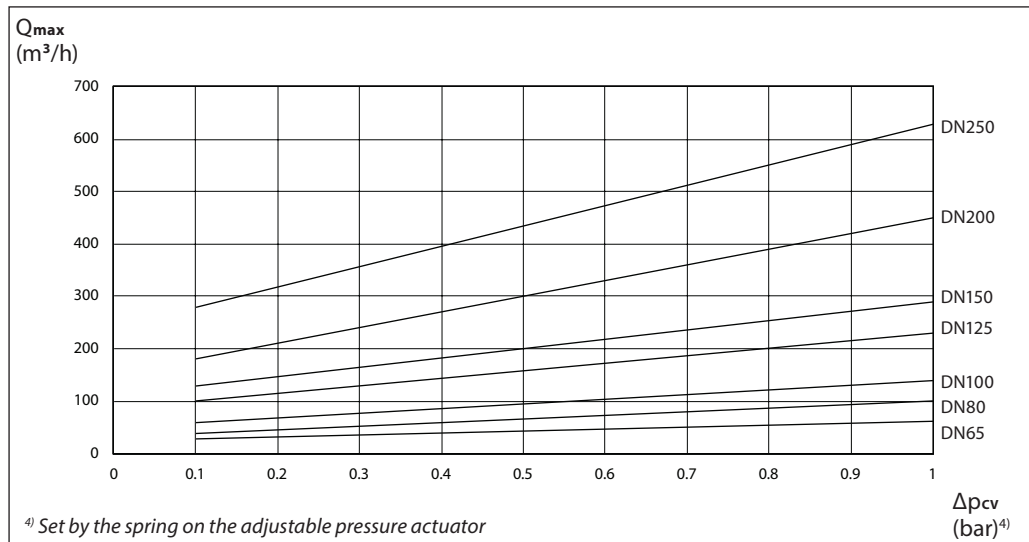

Operating area

Maximum allowed differential pressure over the controller (Δp_{max}) at different cavitation factors (z)

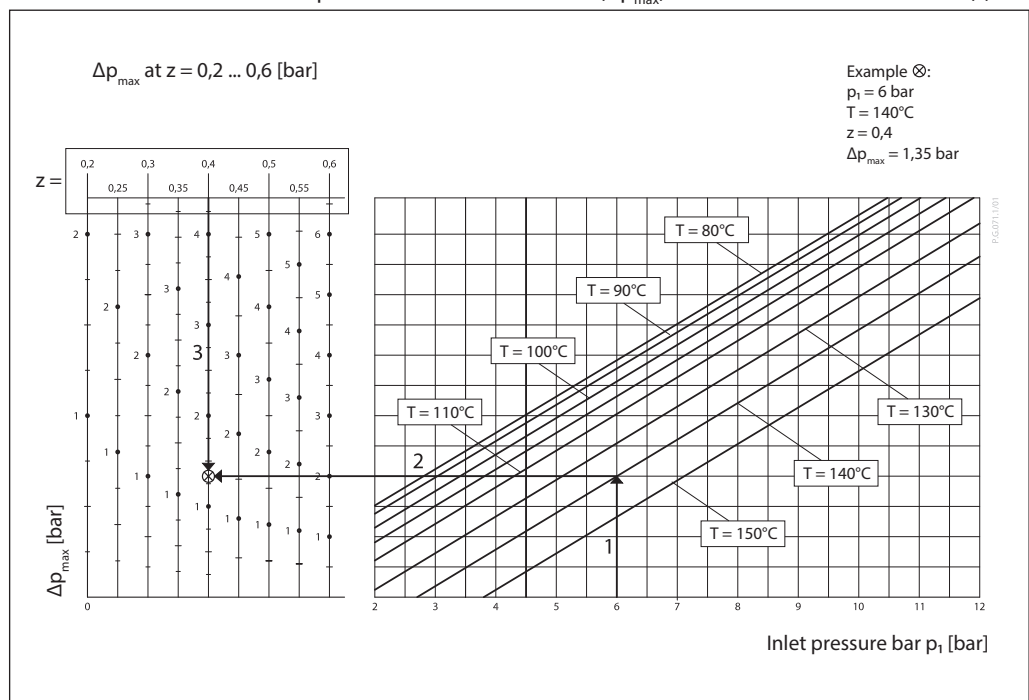

Application principles
- Return mounting

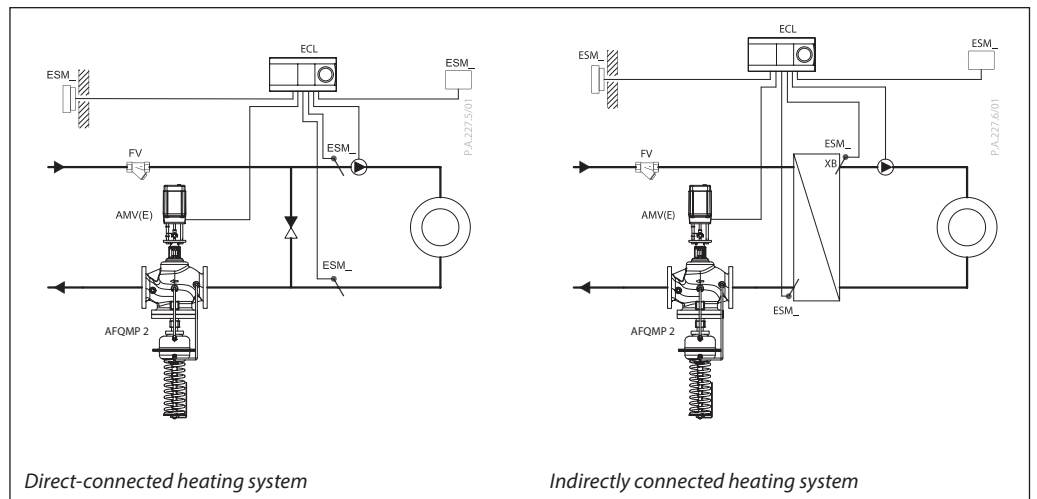

- Flow mounting

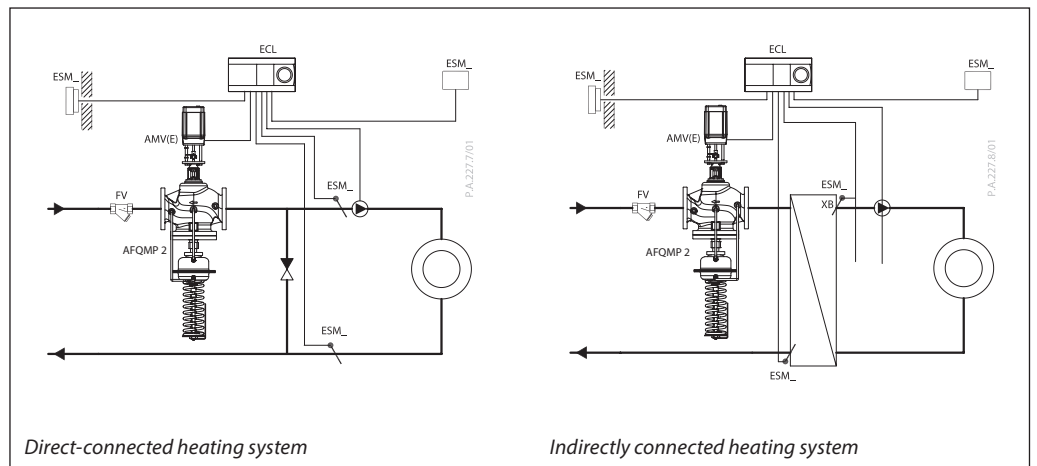

Installation positions

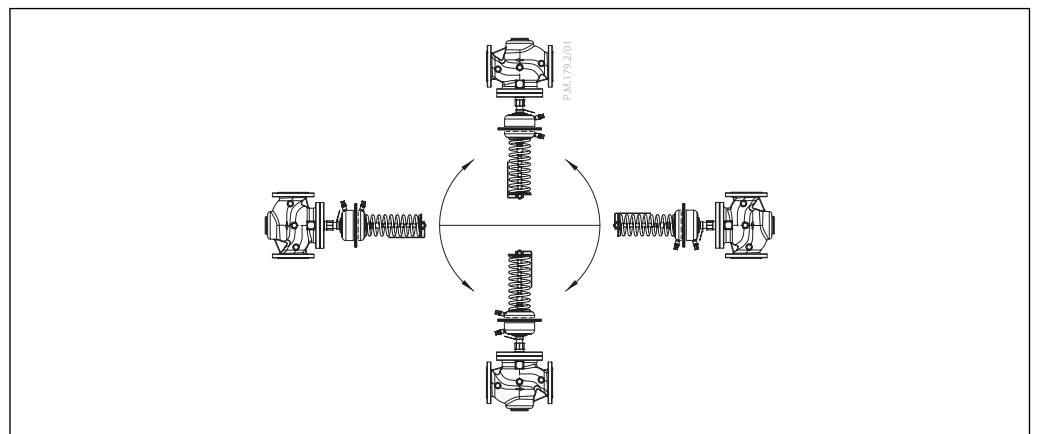

Note!
Installation positions for electrical actuators AMV(E) have to be observed as well. Please see relevant Data sheet.

Pressure temperature diagram

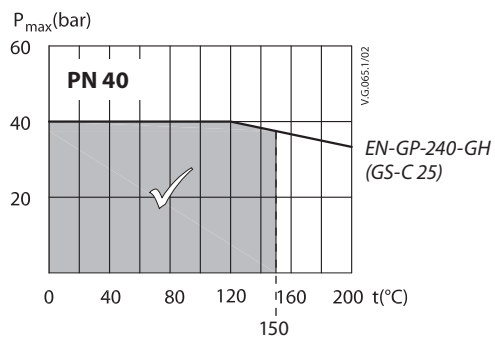
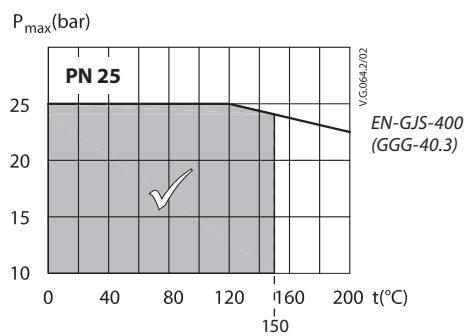
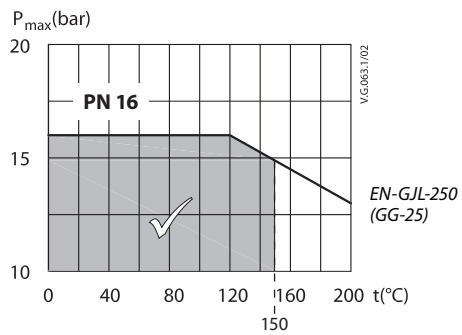

Maximum allowed operating pressure as a function of media temperature (according to EN 1092-2)

Design

- 1. Valve body
- 2. Flow control insert
- 3. Flow stuffing box
- 4. Max. flow limitation nut
- 5. Valve seat
- 6. Pressure control insert
- 7. Pressure actuator
- 8. Pressure actuator diaphragm
- 9. Pressure actuator spring
- 10. Diaphragm excess pressure safety valve
- 11. Flow control cone (CV)
- 12. Pressure control cone (DP)
- 13. Impulse tube
- 14. Union nut
- 15. Cover
- 16. Connection for electrical actuator
- 17. Pressure stuffing box
- 18. Setting scale
- 19. Setting indicator
- 20. Differential pressure setting nut

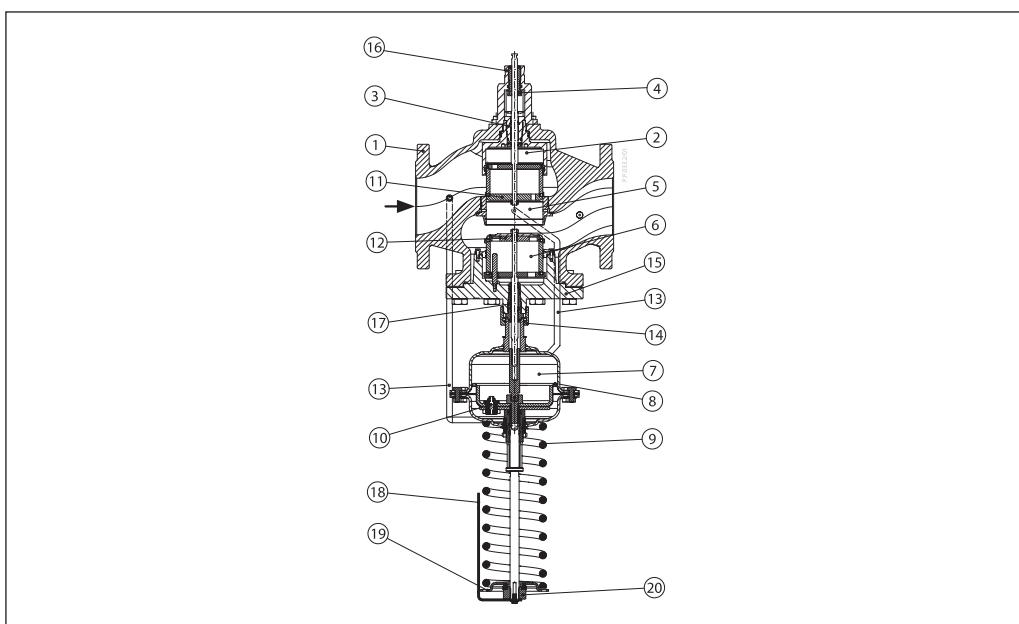

Settings

Flow setting

Flow limitation is being done by the adjustment of the max. flow limitation nut. The adjustment can be performed on the basis of flow limiting diagram (see relevant instructions) and/or by the means of heat meter. Flow limiting curves in diagrams represent informational values, for more accurate flow limitation setting use flow/heat meter.

Differential pressure setting

Differential pressure setting is being done by the adjustment of the setting spring for diff. pressure control. This is done by rotating the differential pressure setting nut. Set differential pressure should be checked by observing the pressure indicators.

Flow limiting

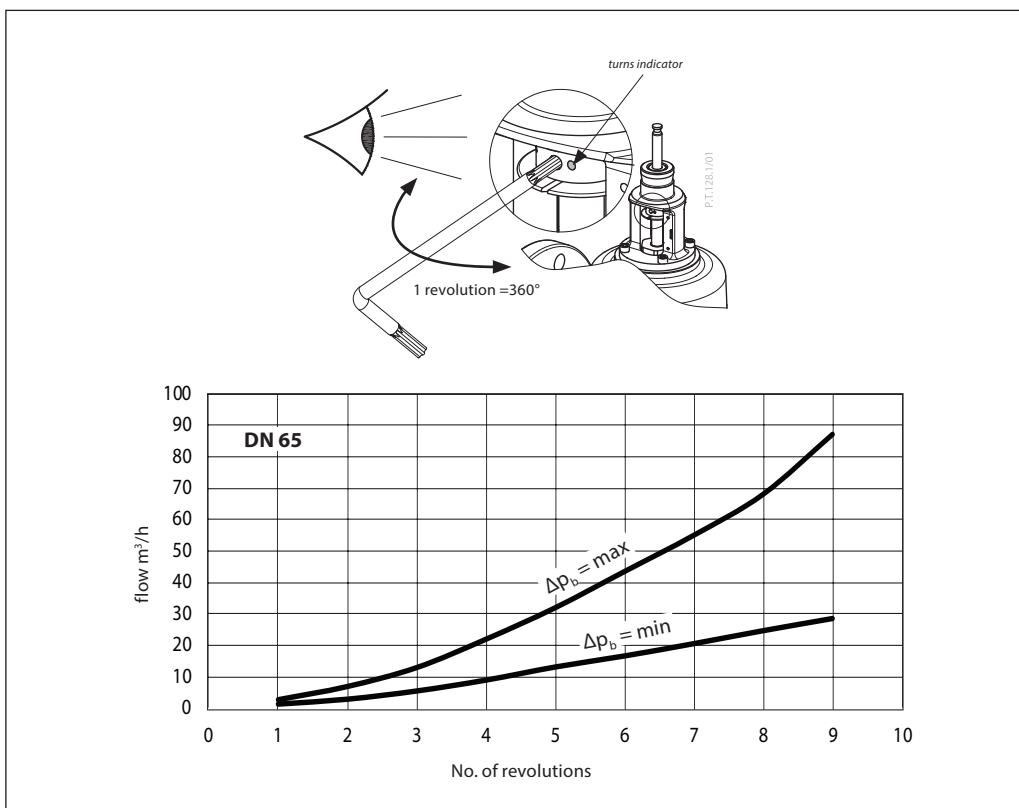

Flow limiting (continuous)

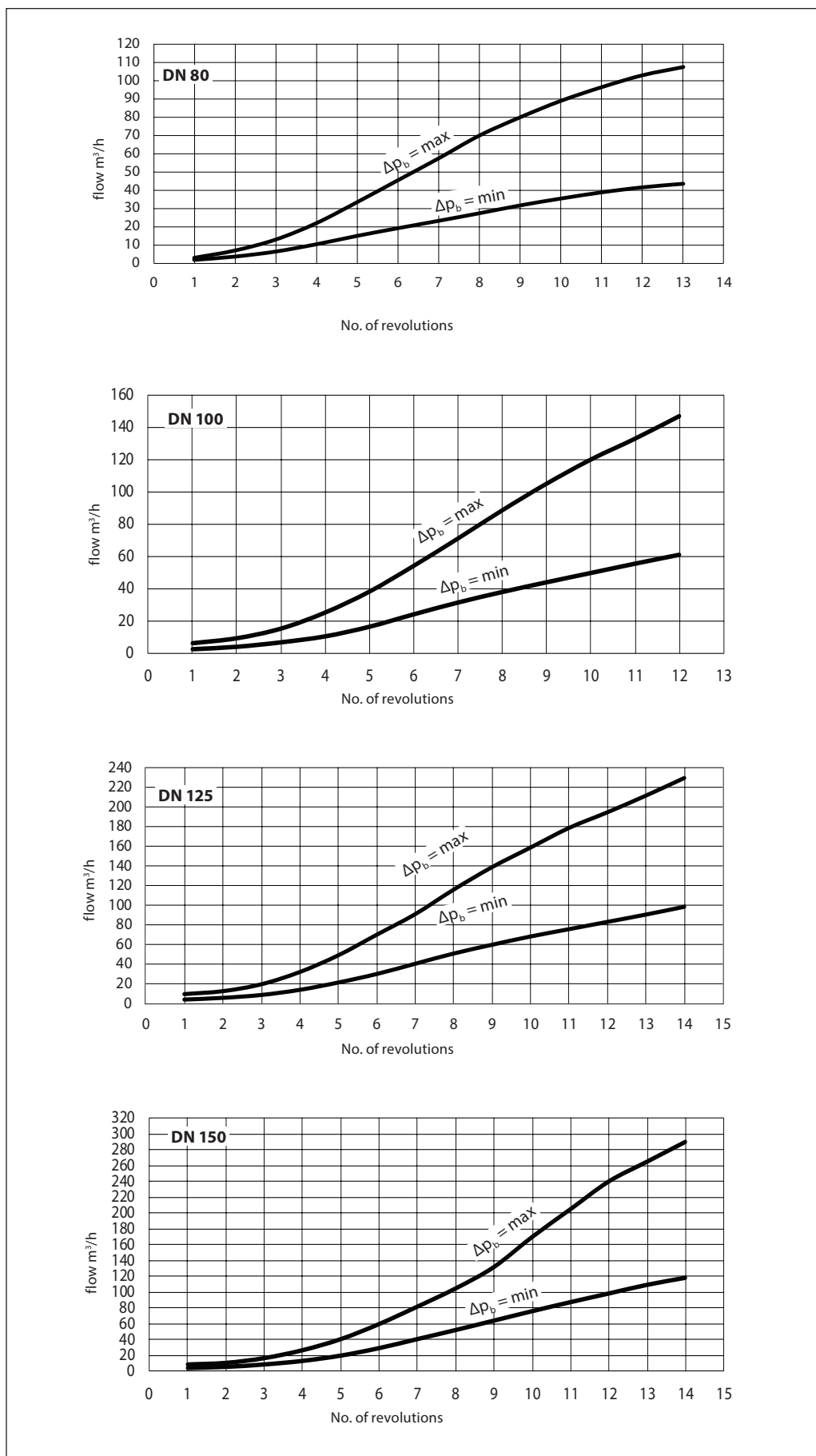

Flow limiting (continuous)

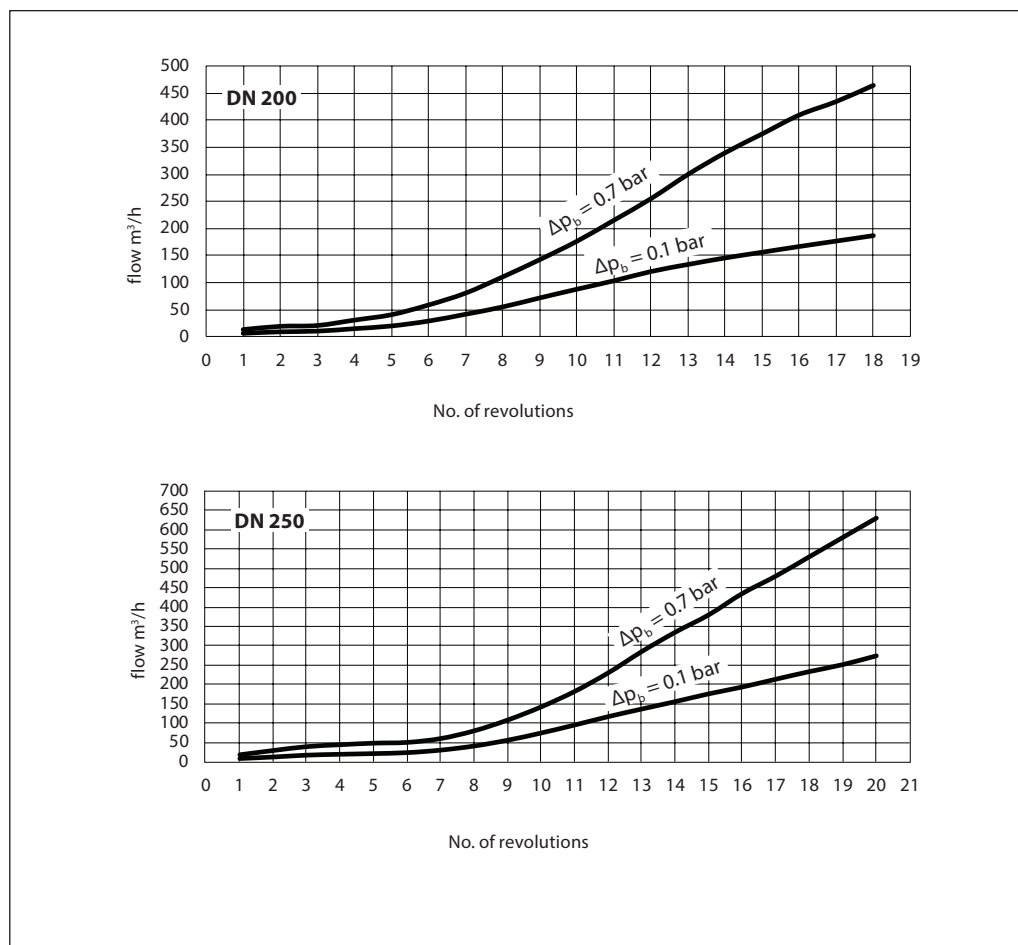

Function

Flow control

Flow control cone adjusts the flow by opening and closing. This action is provided by an electric actuator. The max flow is limited by limiting the maximal opening of the flow control cone. This is done by rotating the flow limitation nut. The pressure independent flow control is achieved by maintaining a constant differential pressure over the flow control cone.

The differential pressure over the flow control cone is lead to the pressure actuator diaphragm through the impulse tubes. It is factory preset. The opening/closing of the pressure control cone is performed by changing differential pressure over the diaphragm.

When differential pressure over the flow control cone:

- a) rises, the pressure control cone takes over the exceeded differential pressure by closing, until set differential pressure over the flow control cone is reached.
- b) drops, the pressure control cone compensates the missing differential pressure by opening, until set differential pressure over the flow control cone is reached.

Pressure actuator diaphragm is equipped with excess pressure safety valve to protect diaphragm from the damages caused by too high differential pressure.

Differential pressure control

Is achieved by maintaining a constant differential pressure over the control valve.

The differential pressure over the control valve is lead to the pressure actuator diaphragm through the impulse tubes.

The opening/closing of the pressure control cone is performed by changing differential pressure over the diaphragm.

When differential pressure over the control valve:

- a) rises, the pressure control cone takes over the exceeded differential pressure by closing, until set differential pressure over the control valve/application is reached.

- b) drops, the pressure control cone compensates the missing differential pressure by opening, until set differential pressure over the control valve/application is reached.

The pressure actuator diaphragm is equipped with excess pressure safety valve to protect diaphragm from the damages caused by too high differential pressure.

Dimensions

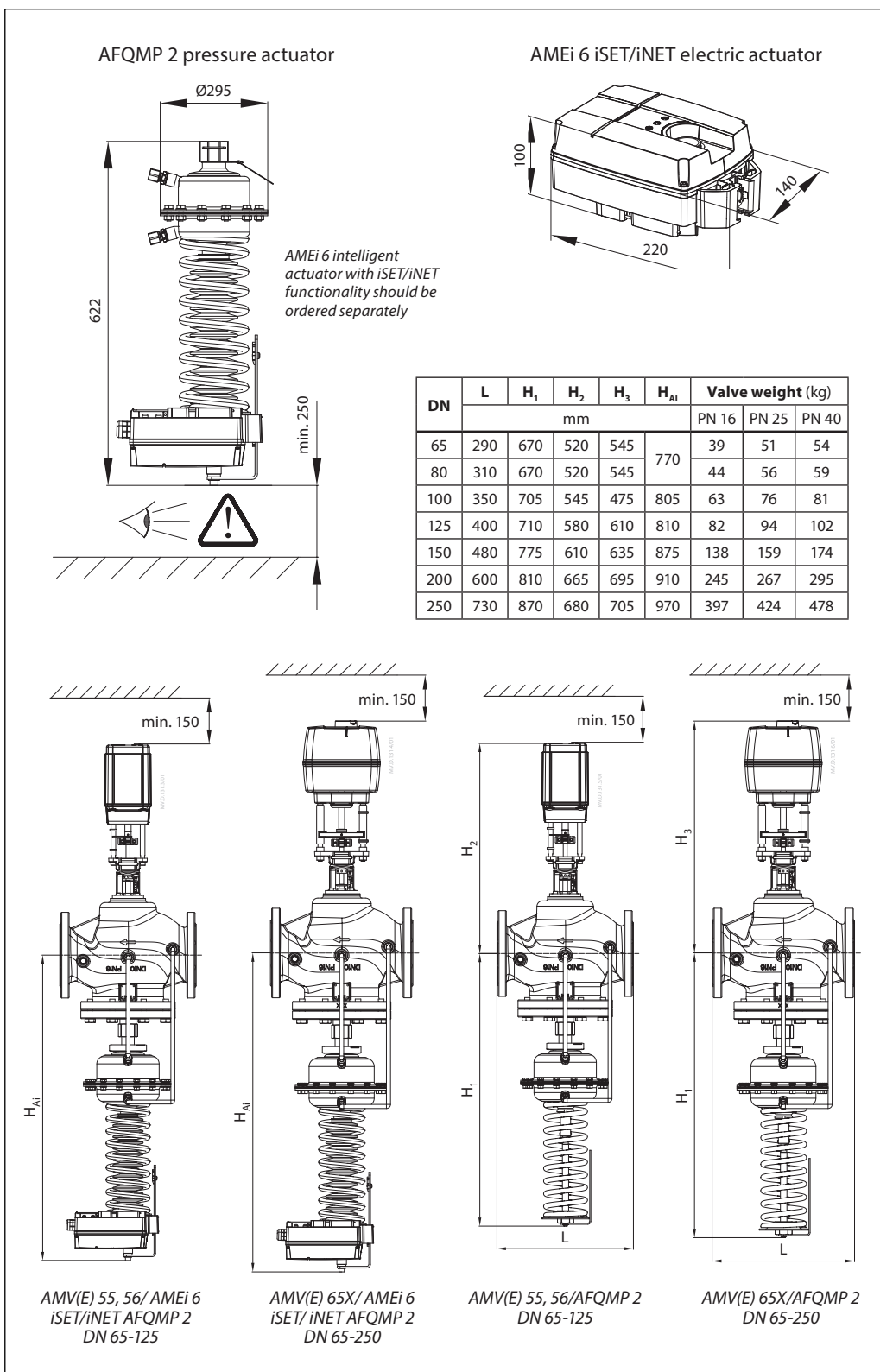



Danfoss A/S

Climate Solutions • danfoss.com • +45 7488 2222

Any information, including, but not limited to information on selection of product, its application or use, product design, weight, dimensions, capacity or any other technical data in product manuals, catalogues descriptions, advertisements, etc. and whether made available in writing, orally, electronically, online or via download, shall be considered informative, and is only binding if and to the extent, explicit reference is made in a quotation or order confirmation. Danfoss cannot accept any responsibility for possible errors in catalogues, brochures, videos and other material. Danfoss reserves the right to alter its products without notice. This also applies to products ordered but not delivered provided that such alterations can be made without changes to form, fit or function of the product.

All trademarks in this material are property of Danfoss A/S or Danfoss group companies. Danfoss and the Danfoss logo are trademarks of Danfoss A/S. All rights reserved.