



**ЮГОВ -Проект**  
інженерно-виробниче підприємство

Офіційний дистриб'ютор  
Danfoss в Україні



# SONO 3500 CT

Ultrasonic Flowmeter

Operating Instructions

Edition

11/2020





# Ultrasonic Flowmeter SONO 3500 CT

## Operating Instructions

Introduction	1
Safety notes	2
Description	3
Installing/Mounting	4
Electrical connection	5
Commissioning	6
Functions	7
Service and maintenance	8
Troubleshooting/FAQs	9
Technical data	10
Parameter lists	A
Settings	B

## Legal information

### Warning notice system

This manual contains notices you have to observe in order to ensure your personal safety, as well as to prevent damage to property. The notices referring to your personal safety are highlighted in the manual by a safety alert symbol, notices referring only to property damage have no safety alert symbol. These notices shown below are graded according to the degree of danger.

#### **DANGER**

indicates that death or severe personal injury **will** result if proper precautions are not taken.

#### **WARNING**

indicates that death or severe personal injury **may** result if proper precautions are not taken.

#### **CAUTION**

indicates that minor personal injury can result if proper precautions are not taken.

#### **NOTICE**

indicates that property damage can result if proper precautions are not taken.

If more than one degree of danger is present, the warning notice representing the highest degree of danger will be used. A notice warning of injury to persons with a safety alert symbol may also include a warning relating to property damage.

### Qualified Personnel

The product/system described in this documentation may be operated only by **personnel qualified** for the specific task in accordance with the relevant documentation, in particular its warning notices and safety instructions.

Qualified personnel are those who, based on their training and experience, are capable of identifying risks and avoiding potential hazards when working with these products/systems.

### Proper use of Danfoss products

Note the following:

#### **WARNING**

Danfoss products may only be used for the applications described in the catalog and in the relevant technical documentation. If products and components from other manufacturers are used, these must be recommended or approved by Danfoss. Proper transport, storage, installation, assembly, commissioning, operation and maintenance are required to ensure that the products operate safely and without any problems. The permissible ambient conditions must be complied with. The information in the relevant documentation must be observed.

### Trademarks

All names identified by ® are registered trademarks of Danfoss A/S. The remaining trademarks in this publication may be trademarks whose use by third parties for their own purposes could violate the rights of the owner.

### Disclaimer of Liability

We have reviewed the contents of this publication to ensure consistency with the hardware and software described. Since variance cannot be precluded entirely, we cannot guarantee full consistency. However, the information in this publication is reviewed regularly and any necessary corrections are included in subsequent editions.

### Local Importer name and address

For goods delivered to UK, importer name and address is:

Danfoss Ltd.  
Oxford Road  
UB9 4LH Denham  
UK

# Table of contents

<b>1</b>	<b>Introduction</b> .....	<b>9</b>
1.1	Items supplied.....	9
1.2	Checking the consignment .....	10
1.3	Device identification .....	10
1.4	Further Information .....	12
1.5	Transportation and storage.....	13
<b>2</b>	<b>Safety notes</b> .....	<b>14</b>
2.1	General safety instructions .....	14
2.2	Manufacturer's design and safety statement .....	14
2.3	Conformity with European directives .....	15
2.4	Lithium batteries.....	15
2.5	Installation in hazardous area.....	16
<b>3</b>	<b>Description</b> .....	<b>17</b>
3.1	Overview .....	17
3.2	System components .....	17
3.3	Design.....	17
3.4	Features.....	18
3.5	Principle of operation .....	19
<b>4</b>	<b>Installing/Mounting</b> .....	<b>21</b>
4.1	Flowmeter installation .....	21
4.2	Sensor installation .....	21
4.2.1	Inlet/Outlet conditions .....	21
4.2.2	Reduction.....	25
4.2.3	Insulation.....	26
4.3	Transmitter installation (compact/remote versions).....	26
4.3.1	Installation wall mounting kit (remote transmitter) .....	27
<b>5</b>	<b>Electrical connection</b> .....	<b>28</b>
5.1	Backup battery.....	28
5.2	Connecting battery (battery-powered versions and mains-powered versions with back-up battery).....	28
5.3	Connecting sensor link cable.....	29
5.4	Connecting power supply cable (main-powered systems only) .....	30
5.4.1	Connecting pulse output signal cable(s).....	31
5.4.2	Finishing connection .....	32

## Legal information

5.4.2.1	Connecting battery (battery-powered versions and mains-powered versions with back-up battery) .....	33
5.5	Compact and remote transmitters: Connecting output and power supply .....	33
5.6	Optional current output module .....	35
5.6.1	Finishing connection .....	36
5.6.2	Connecting .....	37
5.6.3	Finishing connection .....	37
5.7	Wiring energy calculator type INFOCAL 9 .....	38
5.8	Sealing of SONO 3500 CT .....	38
5.8.1	User sealing .....	38
5.8.2	Verification sealing .....	38
<b>6</b>	<b>Commissioning .....</b>	<b>39</b>
6.1	Introduction .....	39
6.2	Operating the local display .....	39
6.3	Navigating the menu structure .....	40
6.4	Start-up routine .....	41
6.5	Commissioning via PDM .....	42
6.5.1	Installing and connecting the IrDA interface adapter .....	43
6.5.2	Installing EDD files .....	43
6.5.3	Adding the device to the network .....	44
6.5.4	Configuring the device .....	44
6.5.5	Optimizing the system .....	46
6.5.6	Output A, terminals 56/57: .....	47
6.5.7	Output B, terminals 66/67: .....	48
6.5.8	Checking the operation readiness .....	48
<b>7</b>	<b>Functions .....</b>	<b>50</b>
7.1	Unit selection .....	50
7.2	Number of decimal digits .....	50
7.3	Password-protected data .....	51
7.4	Hardware key .....	51
<b>8</b>	<b>Service and maintenance .....</b>	<b>53</b>
8.1	Maintenance .....	53
8.2	Battery replacement .....	53
8.3	Service menu .....	56
8.4	Technical support .....	57
8.5	Application-specific data - Qualification certificate .....	57
8.6	Qualification certificate .....	59
8.7	Return procedures .....	61
8.8	Battery disposal .....	62

## Legal information

<b>9</b>	<b>Troubleshooting/FAQs</b> .....	<b>63</b>
9.1	Error codes .....	63
9.2	Diagnosing with PDM .....	64
<b>10</b>	<b>Technical data</b> .....	<b>68</b>
10.1	SONO 3500 CT .....	68
10.2	Battery .....	69
10.3	Sensor for SONO 3500 CT .....	70
10.4	Dimensional drawings for SONO 3500 CT .....	71
10.5	Pipe dimensions for SONO 3500 CT .....	71
<b>A</b>	<b>Parameter lists</b> .....	<b>73</b>
A.1	Identification .....	73
A.2	Output .....	74
A.3	Diagnostic .....	76
A.4	Meter setup .....	81
A.5	Human Interface .....	83
A.6	Unit conversion table .....	83
<b>B</b>	<b>Settings</b> .....	<b>85</b>
B.1	Factory settings .....	85
B.2	Factory settings for Modbus communication .....	86



# Introduction

These instructions contain all information required to commission and use the device. It is your responsibility to read the instructions carefully prior to installation and commissioning. In order to use the device correctly, first review its principle of operation.

The instructions are aimed at persons mechanically installing the device, connecting it electronically, configuring the parameters and commissioning it, as well as service and maintenance engineers.

## 1.1 Items supplied

The device can be delivered as either a compact or a remote system.

### Compact system

- Sensor
- Transmitter
- Connection PCB
- DVD with documentation and certificates
- Safety note
- Calibration report
- Sensor link cable
- Connection accessories

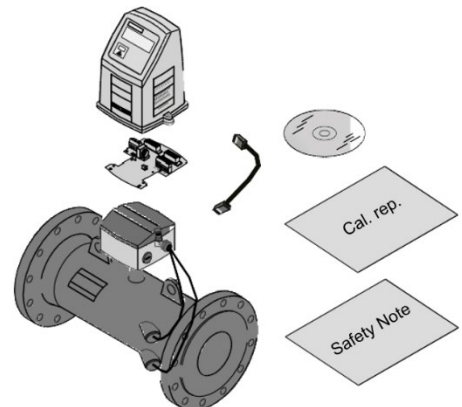

## Remote system

- Sensor
- Transmitter
- Connection PCB
- DVD with documentation and certificates
- Safety note
- Calibration report
- Mounting kit with bracket and terminal box
- Sensor link cable
- Connection accessories

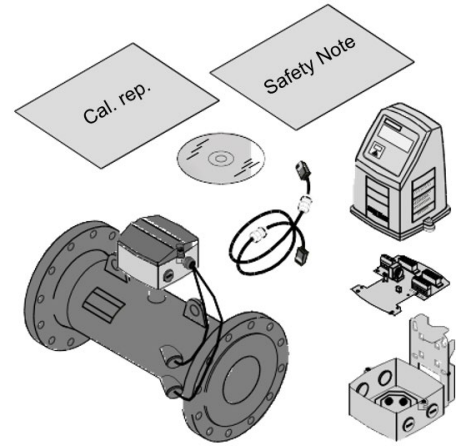

---

### Note

Scope of delivery may vary, depending on version and add-ons. Make sure the scope of delivery and the information on the nameplate correspond to your order and the delivery note.

---

## 1.2 Checking the consignment

1. Check the packaging and the device for visible damage caused by inappropriate handling during shipping.
2. Report any claims for damages immediately to the shipping company.
3. Retain damaged parts for clarification.
4. Check the scope of delivery by comparing your order to the shipping documents for correctness and completeness.

## 1.3 Device identification

The SONO 3500 CT flowmeter is delivered with different labels (nameplates) on the transmitter and sensor. The transmitter and sensor are matched paired.

The transmitter has two nameplates. One (silver) is placed on the front of the transmitter. The transmitter system nameplate (white) is placed on the right side of the transmitter. Both provide valuable information about the device and system. The sensor system nameplate (white) is placed on middle of the sensor.

---

### Note

#### Identification

Identify your device by comparing your ordering data with the information on the product and specification nameplates.

---

## Transmitter system nameplate

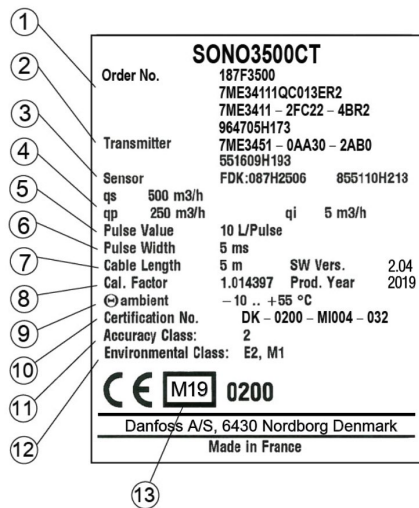

- ① System number (order code identifying selected options and system serial number)
- ② Transmitter production code and serial number
- ③ Sensor production code and serial number
- ④ Maximum flow value (qs), Nominal flow value (qp), Minimum flow value (qi)
- ⑤ Pulse value (output A)
- ⑥ Pulse width (output A)
- ⑦ Cable length (one transducer cable); Software version
- ⑧ Calibration factor; Production year
- ⑨ Ambient temperature range
- ⑩ Type approval number
- ⑪ Accuracy class
- ⑫ Environmental class
- ⑬ Verification markings

Figure 1-1 Transmitter system nameplate

## Sensor system nameplate

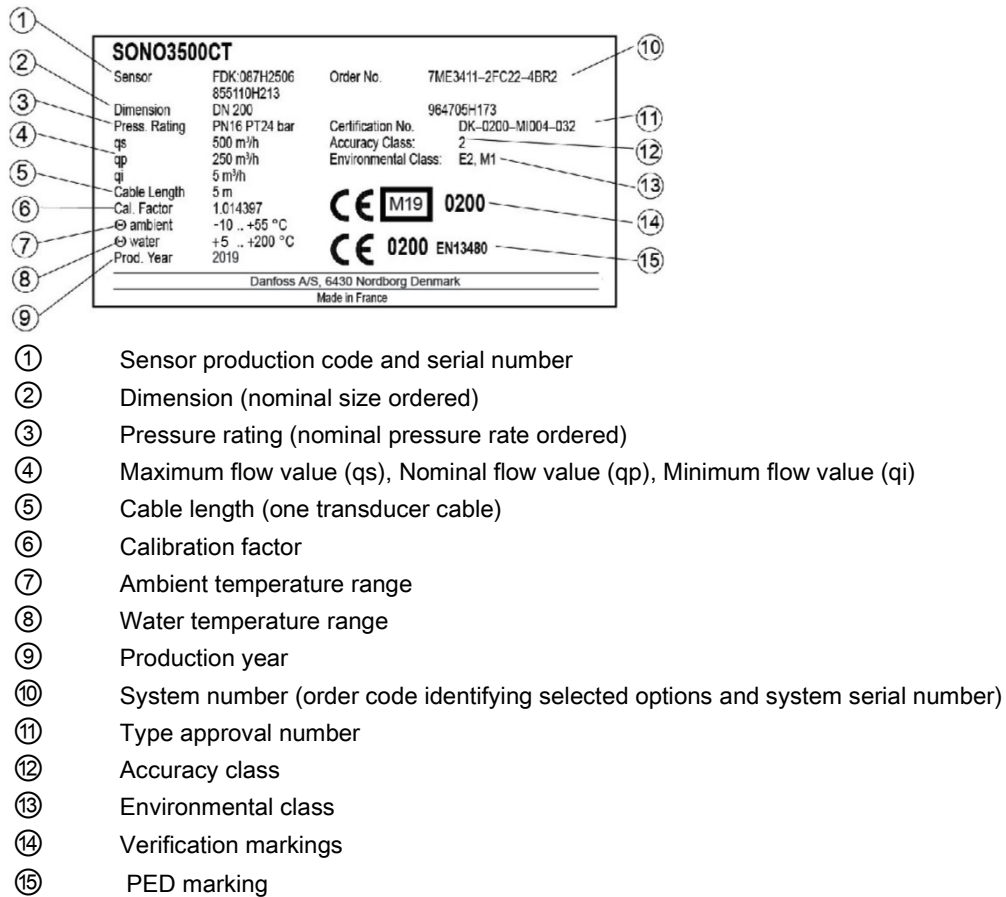

Figure 1-2 Sensor system nameplate

### Note

**The matched paired transmitter and sensor shall be mounted together**

Please check that the system nameplates of transmitter and sensor have the same system serial number.

## 1.4 Further Information

### Product information on the Internet

The Operating Instructions are available on the Danfoss homepage, where further information on the range of Danfoss flowmeters may also be found: Product information (<https://www.danfoss.com/en/products/energy-metering/dhs/energy-metering/>)

## 1.5 Transportation and storage

To guarantee sufficient protection during transport and storage, observe the following:

- 1.3.1 Keep the original packaging for subsequent transportation.
- 1.3.2 Devices/replacement parts should be returned in their original packaging.
- 1.3.3 If the original packaging is no longer available, ensure that all shipments are properly packaged to provide sufficient protection during transport. Danfoss cannot assume liability for any costs associated with transportation damages.

<b>NOTICE</b>
Insufficient protection during storage The packaging only provides limited protection against moisture and infiltration. <ul style="list-style-type: none"><li>• Provide additional packaging as necessary.</li></ul>

## Safety notes

### 2.1 General safety instructions

 <b>CAUTION</b>
<p><b>Correct, reliable operation of the product requires proper transport, storage, positioning and assembly as well as careful operation and maintenance.</b></p> <p>Only qualified personnel should install or operate this instrument.</p>

#### Note

Alterations to the product, including opening or improper modifications of the product are not permitted.

If this requirement is not observed, the CE mark and the manufacturer's warranty will expire.

### 2.2 Manufacturer's design and safety statement

- Responsibility for the choice of flowmeter pipe material as regards abrasion and corrosion resistance lies with the purchaser. The effect of any change in process medium during operation of the meter should be taken into account. Incorrect selection of flowmeter pipe material could lead to failure of the flowmeter.
- Stresses and loading caused by earthquakes, traffic, high winds and fire damage are not taken into account during flowmeter design.
- Do not install the flowmeter such that it acts as a focus for pipeline stresses. External loading is not taken into account during flowmeter design.
- Please be aware of the risk of installing the sensor in a highly vibrating environment. Parts may shake loose and the complete system must be monitored in that case.
- Flanges and joints as well as related pressure/temperature (p/t) classification has been described in EN 1092-1. See ferrite steel group 1E1: table 15.
- During operation do not exceed the pressure and/or temperature ratings indicated on the data label or in these operating instructions.
- It is recommended that all installations include an appropriate safety valve and adequate means for draining.
- Under the „Pressure Equipment Directive" (PED), this product is a pressure accessory and not approved for use as a safety accessory, as defined by the PED.

#### Environmental conditions according MID (Directive 2014/32/EU)

- Environment class: E2 (electromagnetic), M1 (mechanical)
- Climatic class: -10°C - +55°C, condensing, closed

## 2.3 Conformity with European directives

The CE marking on the device symbolizes the conformity with the following European directives:

Electromagnetic compatibility EMC 2014/30/EU

Directive of the European Parliament and of the Council on the harmonization of the laws of the Member States relating to electromagnetic compatibility

Low voltage directive LVD 2014/35/EU

Directive of the European Parliament and of the Council on the harmonization of the laws of the Member States relating to the making available on the market of electrical equipment designed for use within certain voltage limits

Pressure equipment directive PED EMC 2014/68/EU

Directive of the European Parliament and of the Council on the harmonization of the laws of the Member States relating to electromagnetic compatibility

Radio equipment directive RED 2014/53/EU

Directive of the European Parliament and of the Council on the harmonization of the laws of the Member States relating to the making available on the market of radio equipment and repealing Directive 1999/5/EC

Measuring instruments directive MID 2014/32/EU

Directive of the European Parliament and the Council on the harmonization of the laws of the Member States relating to the making available on the market of measuring instruments

Restriction of Hazardous Substances RoHS 2011/65/EU

Directive of the European Parliament and the Council on the restriction of the use of certain hazardous substances in electrical and electronic equipment

The applicable directives can be found in the EU declaration of conformity of the specific device.

## 2.4 Lithium batteries

Lithium batteries are primary power sources with high energy content designed to represent the highest possible degree of safety.

 <b>WARNING</b>
<b>Potential hazard</b>
Lithium batteries may present a potential hazard if they are abused electrically or mechanically.
<ul style="list-style-type: none"><li>• Observe the following precautions when handling and using lithium batteries:<ul style="list-style-type: none"><li>– Do not short-circuit, recharge or connect with false polarity.</li><li>– Do not expose to temperature beyond the specified temperature range or incinerate the battery.</li><li>– Do not crush, puncture or open cells or disassemble battery packs.</li><li>– Do not weld or solder to the battery's body.</li><li>– Do not expose contents to water.</li></ul></li></ul>

## 2.5 Installation in hazardous area

 **WARNING**

**NOT allowed for use in hazardous areas!**

Equipment used in hazardous areas must be Ex-approved and marked accordingly!

This device is NOT approved for use in hazardous areas!

## 3.1 Overview

The SONO 3500 CT ultrasonic flowmeter systems consist of a sensor and a transmitter. The transmitter is type-approved with the custody transfer (CT) approval for use in energy metering systems. The transmitter is designed to measure flow water applications.

The ultrasonic flowmeter transmitter comes as a mains-powered version with battery backup.

The following table shows the ultrasonic flowmeter systems with these transmitter types:

Sensor type	Transmitter	Flowmeter system
SONO 3500 CT (2-path) DN 100 to DN 1200	incl	SONO 3500 CT

## 3.2 System components

The flowmeter system includes:

- Mains-powered transmitter with battery backup
- The sensor is a 2-path sensor with flanges and inline transducers wet-calibrated from factory together with the transmitter (DN 100 (4") to DN 1200 (48"))

## 3.3 Design

The transmitter is designed with fiberglass reinforced polyamide enclosure for remote or compact installation in normal areas. The remote versions are available with up to 30 meter distance from flowmeter to transmitter. When ordered as a compact version in the series SONO 3500 CT the transducer cables are pre-mounted at the sensor.



SONO 3500 CT transmitter



SONO 3500 CT display

The transmitter is available in an IP67/NEMA 4X/6 enclosure.

For spare part cases the transmitter is always ordered as part of a complete flowmeter system.

The transmitter can be ordered preprogrammed with the given sensor data (system serial number).

## 3.4 Features

The following features are available:

- Mains-powered transmitter
- Battery backup with 3.6 V Lithium single D-cell battery
- Suitable for sensor pipe diameters from DN 100 (4") up to DN 1200 (48")
- IP67 (NEMA 4X/6) rated polyamide transmitter enclosure
- Factory preset to the nominal dimensions of pipe type and pipe size
- Programming via SIMATIC PDM
- Local control panel with single push button, 8-digit display and IrDA optical interface for communication with SIMATIC PDM
- Display showing accumulated volume as well as instantaneous flow rate. The displayed units are m<sup>3</sup>/h and m<sup>3</sup>
- Two digital outputs for volume pulse or alarm
- 4-20mA output (optional)

### Applications

The main application for the type-approved SONO 3500 CT flowmeters is measurement of water flow in district heating plants, local networks, boiler stations, substations, chiller plants, irrigations plants, and other general water applications.

### Integration

The flowmeter pulse output is often used as input for an energy meter or as input for digital systems for remote reading. The transmitter has two pulse outputs, with functions that can be individually selected, and integrated IRDA (optical eye) communication interface (Modbus RTU).

The settings of the transmitter, for example flow and pulse output rate, are defined when ordering the complete flowmeter. If the flowmeter forms part of an energy meter system for custody transfer, no further approvals are needed, except possible local approvals.

### Transmitter communication solutions

The transmitter supports Modbus RTU communication via the optical IrDA interface at the display, enabling the change of different transmitter settings using the SIMATIC PDM software tool.

The transmitter is configured in a combination of hardware (HW) and firmware (FW). For the communication and parametrization via SIMATIC PDM a firmware-specific device description (EDD) is needed.

## 3.5 Principle of operation

### Physical principle

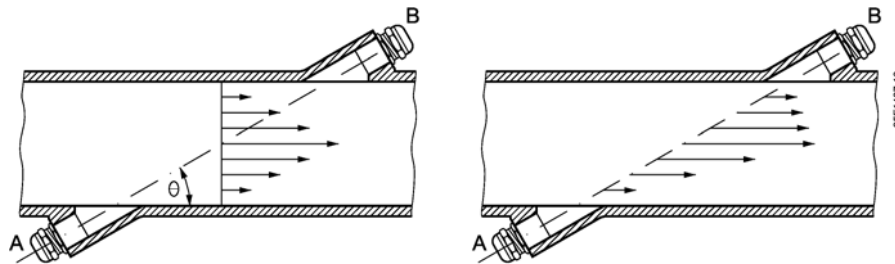

Figure 3-1 Velocity distribution along sound path

A sound wave travelling in the same direction as the liquid flow arrives at point B from point A in a shorter time than the sound wave travelling against the flow direction (from point B to A).

The difference in sound transit time indicates the flow velocity in the pipe.

Since delay time is measured at short intervals both in and against flow direction, temperature has no influence on measurement accuracy.

### SONO 3500 CT flowmeters

In SONO 3500 CT flowmeters the ultrasonic transducers are placed at an angle  $\theta$  in relation to the pipe axis. The transducers function as transmitters and receivers of the ultrasonic signals. Measurement is performed by determining the time the ultrasonic signal takes to travel with and against the flow. The principle can be expressed as follows:

$$v = K \times (t_{B,A} - t_{A,B}) / (t_{A,B} \times t_{B,A}) = K \times \Delta t / t^2$$

where

$v$  = Average flow velocity

$t$  = Transit time

$K$  = Proportional flow factor

This measuring principle offers the advantage that it is independent of variations in the actual sound velocity of the liquid, i.e. independent of the temperature.

The mechanical/geometrical pipe data is transducer angle ( $\theta$ ), distance between sensors ( $L$ ) and pipe dimension ( $D_i$  and  $D_o$ ) shown in the figure below.

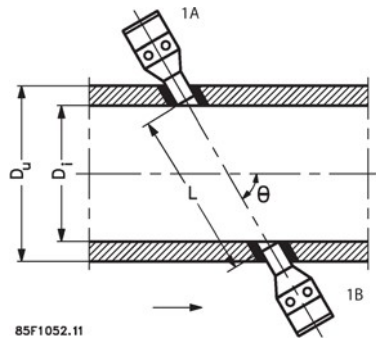

Figure 3-2 Measuring principle

The ultrasonic signal is sent directly between the transducers. The advantage gained sending signals from point to point is an extremely good signal strength.

# Installing/Mounting

## 4.1 Flowmeter installation

The flowmeter installation is done in two steps:

1. Sensor installation
2. Transmitter installation

### Environment

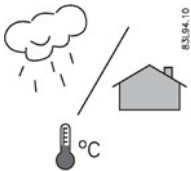

SONO 3500 CT flowmeters are suitable for indoor and outdoor installations.

- Make sure that temperature and ambient specifications indicated on the device type plate/label are not exceeded.

 <b>CAUTION</b>
<p><b>Direct sunlight</b></p> <p>Device damage.</p> <p>The device can overheat or materials become brittle due to UV exposure.</p> <p>Protect the device from direct sunlight.</p> <p>Make sure that the maximum permissible ambient temperature is not exceeded.</p> <p>Refer to the information in Technical data (Page 68).</p>

Ambient temperature for transmitter:

- -10 °C to +55 °C (14 to 131 °F)
- Non-MID versions -10 to +60°C (14 to 140°F)
- The enclosure rating of the transmitter is IP67 (NEMA 4X/6) or better.

## 4.2 Sensor installation

### 4.2.1 Inlet/Outlet conditions

#### Requirement for straight inlet before flowmeter

In order to maximize performance it is necessary to have straight inlet and outlet flow conditions before and after the flowmeter.

Furthermore, a minimum distance between flowmeter and pumps and valves must be respected.

It is also important to centre the flowmeter in relation to flanges and gaskets.

Make sure that flowmeter is positioned as low as possible to prevent air from being trapped in flowmeter at transducers.

Find a position on the pipeline where inlet pipe to flowmeter has a straight length as specified below.

## Single bend

1 x 90° bend

L2: Min. 10 x pipe diameter

L1: 3 x pipe diameter

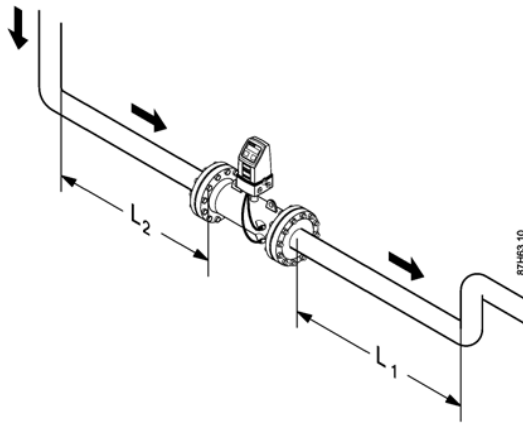

## Dual bend

**2 x 90° bends in the same plane**

L2: Min. 10 x pipe diameter

L1: 3 x pipe diameter

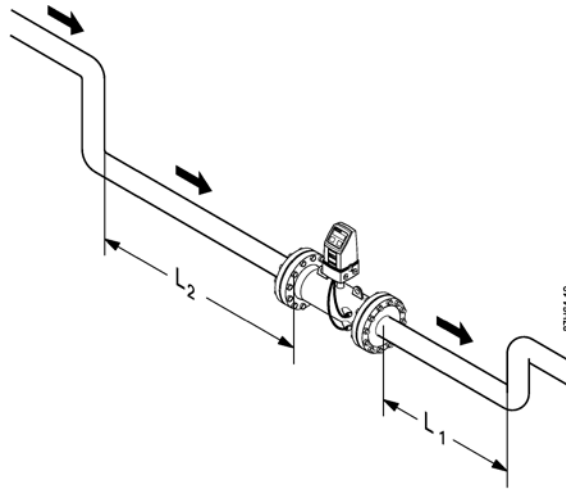

## Triple bend

**3 x 90° bends in two planes**

L2: Min. 20 x pipe diameter

L1: 3 x pipe diameter

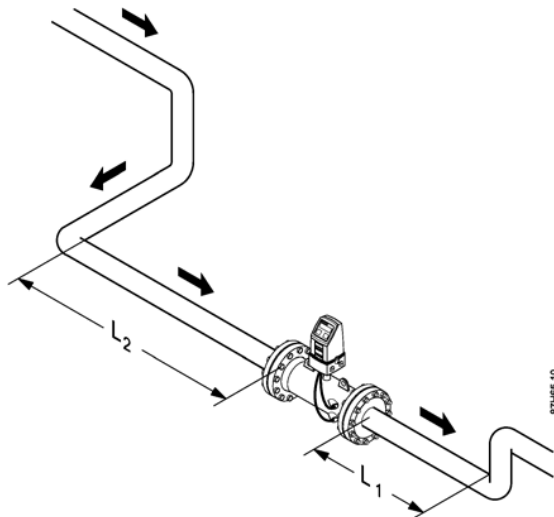

## Valves and pumps

### Valves

L2: Min. 10 x pipe diameter, fully open valve

L1: 3 x pipe diameter

### Pumps:

L2: Min. 20 x pipe diameter

L1: 3 x pipe diameter

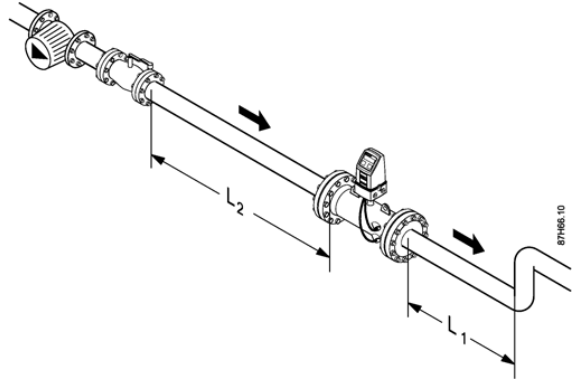

## Orienting the sensor

Horizontal orientation, terminal box upwards or downwards

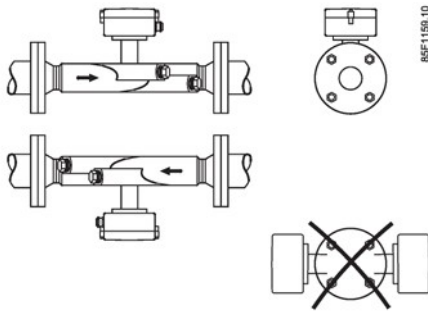

In horizontal installation avoid any upward/downward position of the transducers.

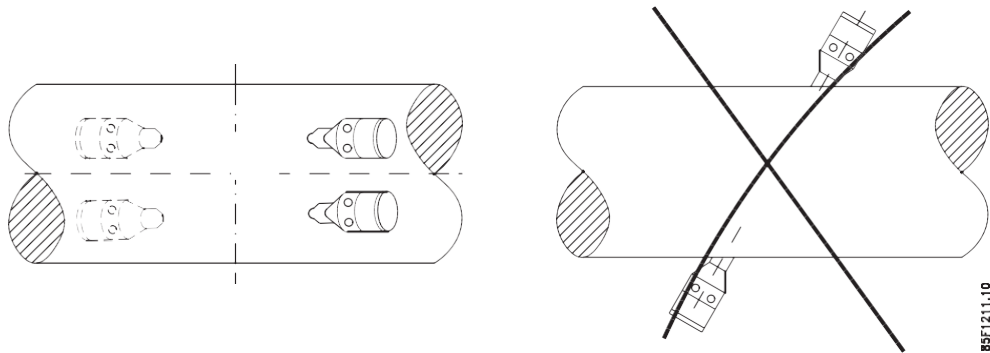

## Precautions

Avoid installation at the highest point in the system because air bubbles will be trapped in flowmeter.

Avoid installation at a point where there is a free outlet after flowmeter.

Flowmeter pipe section may be installed in either a horizontal or vertical position.

**Note**

To obtain maximum battery lifetime with the Lithium Thionyl Chloride battery pack, it is recommended to install the flowmeter transmitter in an upright position.

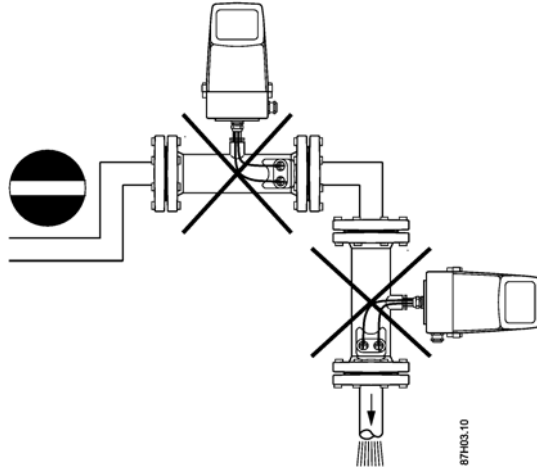

**4.2.2 Reduction**

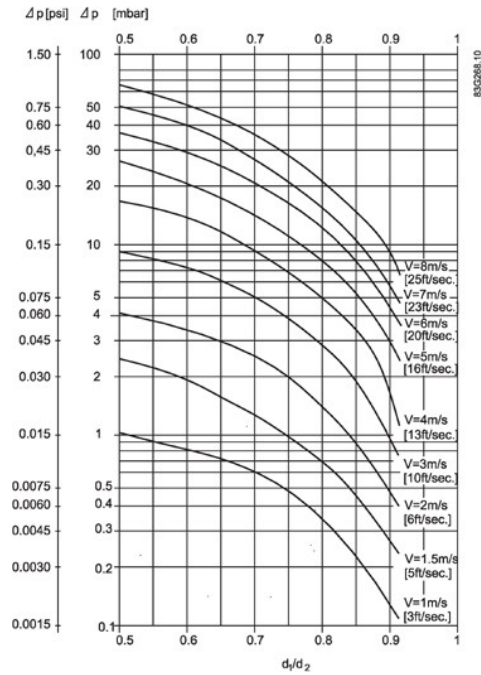

### Installation in large pipes

The flowmeter can be installed between two reducers as shown. At 8° reducing angles the below pressure drop curve applies.

#### Delta-P example:

A water flow velocity of 3 m/s (V) in a sensor with a diameter reduction from DN 200 to DN 100 ( $D_1/D_2 = 0.5$ ) gives a pressure drop of 9 mbar.

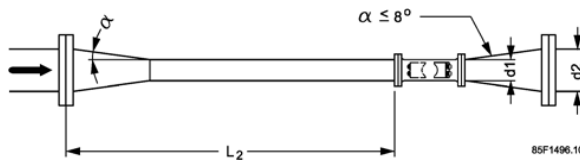

L2: Min. 10 x pipe diameter

### 4.2.3 Insulation

Both versions can be insulated.

We always recommend insulation of sensor in the compact or remote version. For compact versions the insulation can prevent heat transfer to transmitter.

### 4.3 Transmitter installation (compact/remote versions)

The transmitter is packed separately - ready for plug-in into base part.

There are two mounting versions of the transmitter (as shown in figures below):

- remote transmitter
- compact transmitter

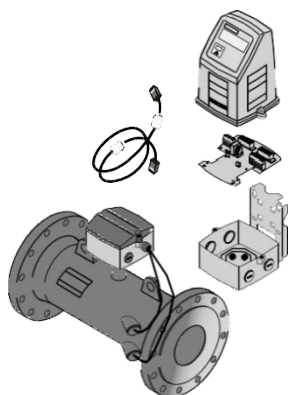

Remote transmitter

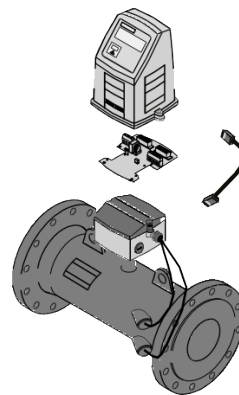

Compact transmitter

---

#### Note

The matched paired transmitter and sensor shall be mounted together. At installation, please check that the system nameplates of transmitter and sensor have the same system serial number.

---

### 4.3.1 Installation wall mounting kit (remote transmitter)

Mount wall/pipe mounting bracket in an appropriate place.

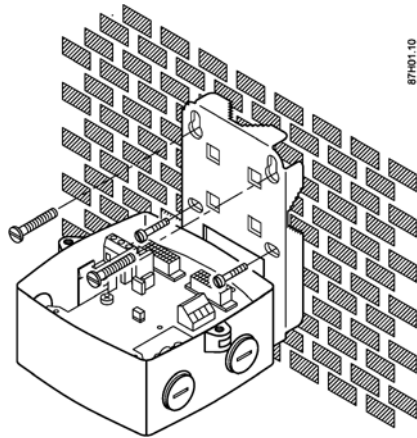

Wall mounting

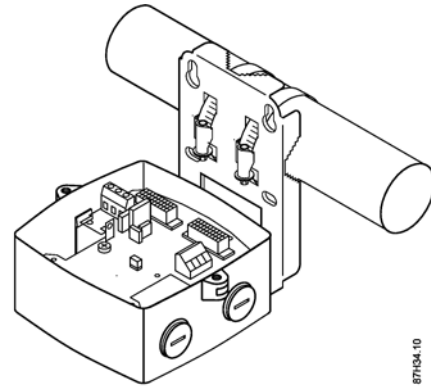

Pipe mounting

---

#### Note

Take coaxial cable length into consideration and allow adequate space for cable inlets underneath and on both sides.

---

## Electrical connection

The transmitter is mains-powered with battery backup

### Important:

On compact versions, all transducer cables are pre-mounted from factory.

Mounting of output pulse cables is identical for compact and remote versions.

### WARNING

#### Skills

Only qualified personnel may carry out work on the electrical connections.

### WARNING

#### Danger of electric shock!

Never install the device with the mains voltage switched on!

## 5.1 Backup battery

The mains-powered transmitter is supplied with a single backup lithium battery.

In the event of power failure battery will take over power supply of unit.

The battery is not of a rechargeable type and must be replaced latest after 6 years.

### Note

Male battery plug is not connected to plug female socket connection upon delivery. This connection must be made to enable backup battery power supply.

## 5.2 Connecting battery (battery-powered versions and mains-powered versions with back-up battery)

Plug in male battery plug. Ensure that the wire is inserted into the small channel leading from plug to battery.

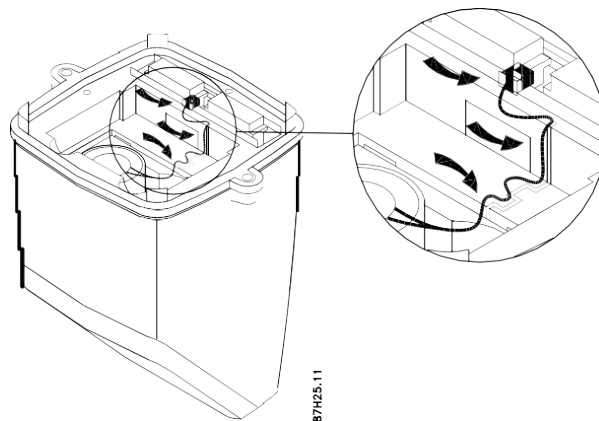

87425.11

## 5.3 Connecting sensor link cable

1. Remove the plastic lid from the terminal box.
2. Click the sensor link cable onto sensor connection board (A) and onto transmitter connection board (B).

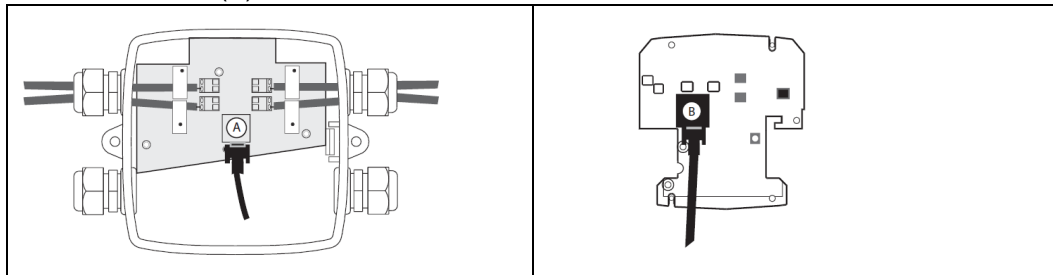

3. Turn the transmitter connection board so that the connection cable is facing downwards.

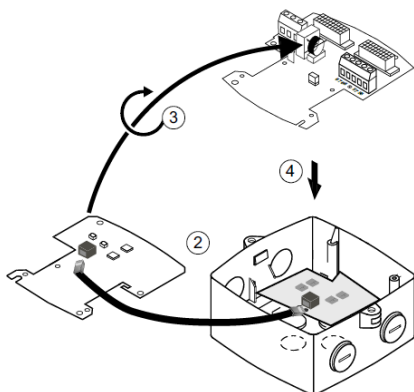

4. Click the transmitter connection board into the terminal box.
5. Connect protective earth wire.

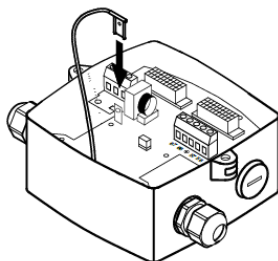

## 5.4 Connecting power supply cable (main-powered systems only)

### **⚠ WARNING**

#### **Power supply requirements**

Make sure the power supply requirements stated on the nameplates are met!

### **⚠ WARNING**

#### **Wire insulation**

The insulation between the connected mains supply and the low voltage supply for the flowmeter must be rated with at least double or reinforced insulation at mains voltage.

For field wiring installation: Ensure that the **National Installation Code** of the country in which the flowmeters are installed is met.

#### **Note**

##### **Conductor terminal**

The wire size for the output terminals are AWG24 to AWG16 or 0.205 mm<sup>2</sup> to 1.500 mm<sup>2</sup>.

1. Replace blind plug with cable gland.
2. Push power supply cable through open gland.
3. Connect power supply to L1, N and protective earth (PE) and tighten cable strap (C).

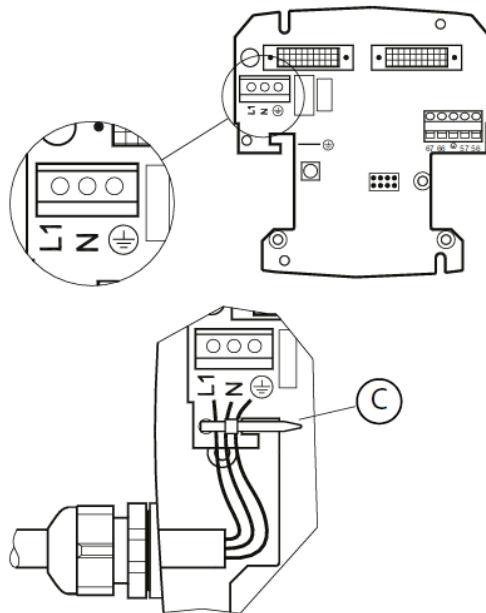

5. Tighten cable gland for power supply cable (approx. 20 Nm).

## 5.4.1

### Connecting pulse output signal cable(s)

If no output signals are needed, proceed with "Finishing connection".

**⚠ CAUTION**

**Pulse output**

The pulse output must be connected to equipment complying with Low-Voltage Directive in order to be considered safe. The isolation within FUS080 pulse output is only a functional isolation.

1. Replace blind plug with cable gland (if two output signals are required, use a double entry cable gland).
2. Push output cable(s) through open gland.
3. Connect output cable(s).

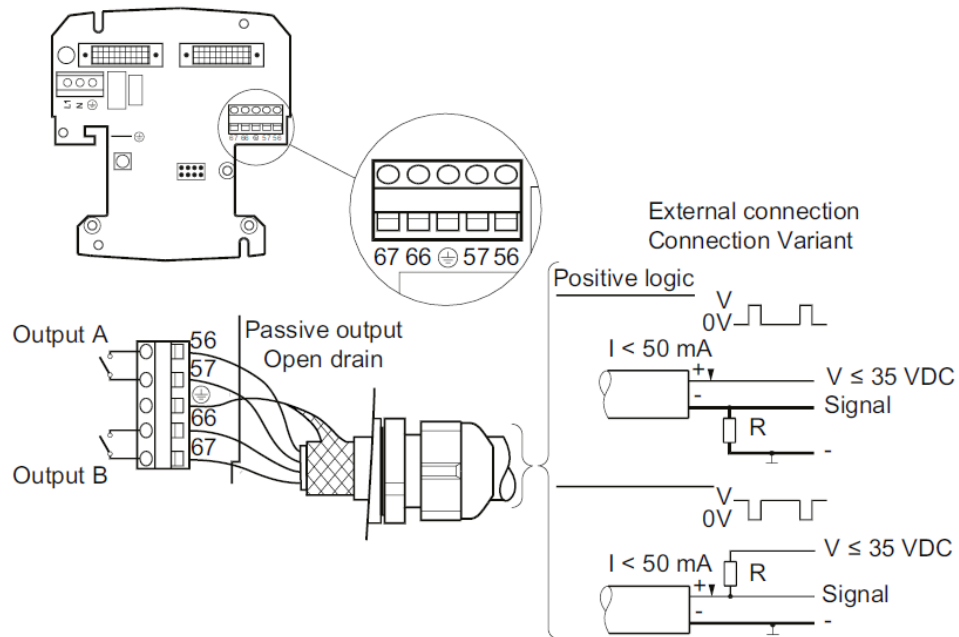

4. Tighten cable gland for output cable(s) (approx. 20 Nm).

---

#### Note

##### Cables with voltage

Keep the output signal cable(s) separated from cables with voltages > 60 V.

---

#### Note

##### Ingress protection

To guarantee the IP67 (NEMA 4X/6) degree of protection, use cables with the required specifications.

---

#### Note

##### Protected terminal

Keep the output signal cable(s) separated from cables with voltages > 60 V.

---

---

**Note****EMC performance**

Incorrect fixing of the output cable shield will affect the EMC performance.

---

**Note****Optional current output module**

If you want to install the optional current output module, proceed with chapter Installing and connecting optional current output module (Page 35) before mounting the transmitter.

---

## 5.4.2

### Finishing connection

Mount the transmitter.

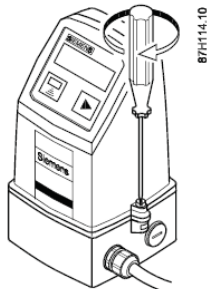

---

**Note****Grounding**

To ensure identical potential for sensor and transmitter, a direct grounding of transmitter and sensor is recommended.

---

**Note****Aligning the gasket**

Please ensure that the gasket between terminal box and transmitter is well aligned before tightening the screw (Min. torque 0.5 Nm).

---

### 5.4.2.1 Connecting battery (battery-powered versions and mains-powered versions with back-up battery)

Plug in male battery plug. Ensure that the wire is inserted into the small channel leading from plug to battery.

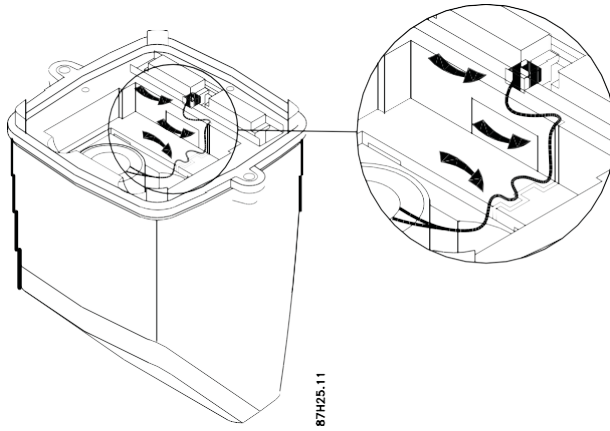

## 5.5 Compact and remote transmitters: Connecting output and power supply

The wiring of output and power supply is done in three steps:

1. Wiring power supply
2. Wiring pulse output (if relevant)
3. Mounting transmitter

### Step 1: Wiring power supply

 <b>WARNING</b>
<b>Power supply requirements</b>
Make sure the power supply requirements stated on the nameplates are met!

1. Connect power supply to L1, N and protective earth (PE).

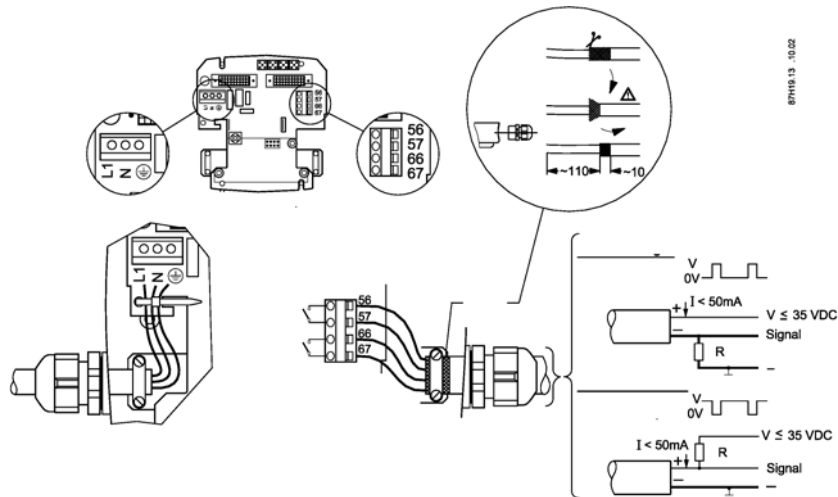

Figure 5-2 Output and power supply connection

2. Fix the power supply cable to the terminal housing with the clamp.
3. Ground transmitter and sensor.

#### Note

##### Cable straps

It is recommended to use cable straps.

#### Note

##### Sensor grounding

To ensure identical potential for sensor and transmitter, a direct grounding of transmitter and sensor is recommended.

### Step 2: Wiring pulse output

#### ⚠ CAUTION

##### Pulse output

The pulse output must be connected to equipment complying with Low Voltage Directive in order to be considered safe. The isolation within the transmitter pulse output is only a functional isolation.

1. Prepare the cable ends as shown in the figure above.
2. Connect output cables to terminals 56 and 57 (Output A) and to 66 and 67 (Output B) according to use.  
The output functions are used as shown in the figure above.
3. Ground the cable shielding by fixing it with the clamp.

**⚠ CAUTION**

EMC performance

Incorrect fixing of the cable shield will affect the EMC performance!

**Step 3: Mounting Transmitter**

1. Tighten the power supply and pulse output cable glands.
2. Mount the transmitter.

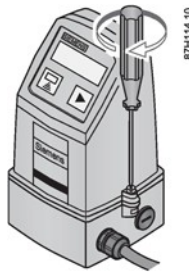

Figure 5-3 Mounting transmitter on terminal box

## 5.6 Optional current output module

The optional current output module converts the flow signal into a 4-20 mA output signal. The 4 mA always equals 0 flow rate and the 20 mA equals the Q<sub>p</sub> value selected via the order code. The default Q<sub>p</sub> can be found on the transmitter nameplate.

The current output module is passive and therefore needs an external power supply.

---

**Note****Current output range during start up**

When the current output module is enabled (default setting) the output is 3.6 mA during start up. When the current output module is disabled the output is fixed to 4 mA.

---

**Note****Restricted use of the optional current output module**

The module can be used with all mains-powered SONO3500 CT versions, but the output signal is not approved for custody transfer use.

---

## 5.6.1

### Finishing connection

**⚠ WARNING**

**Danger of electric shock!**

Never install the device with the mains voltage switched on!

**⚠ CAUTION**

**EMC performance**

Current output cable shield must be connected. Incorrect fixing of the cable shield may affect the EMC performance!

**Note**

**Power supply**

The current output module is a passive module and should only be used with external power supply.

**Note**

**Current output module**

To support the function with current output module the default communication settings for the transmitter is recommended. See Factory settings for Modbus communication (Page 85).

## Installing

1. Remove transmitter/terminal box lid.
2. Carefully mount current output module on the eight pins.

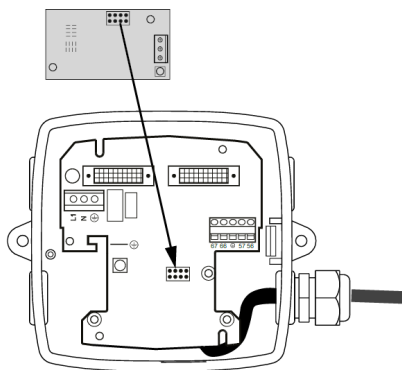

3. Fasten module to transmitter connection board by use of a M3x5 screw (0.5 Nm).

**⚠ CAUTION**

**Protective earth**

The M3x5 screw also functions as earth conductor (EMC).

## See also

Optional current output module (Page 35)

## 5.6.2 Connecting

The output terminals are marked 31 and 32 with corresponding polarity + and - on the terminal strip. The connector  $\ominus$  is for shielding.

The requirements for the current output cable, for example max. load can be found in AUTOHOTSPOT.

1. Replace blind plug with cable gland (if two output signals are required, use a double entry cable gland).
2. Push output cable through open gland.
3. Connect output cable to terminals 31, 32 and  $\ominus$ .

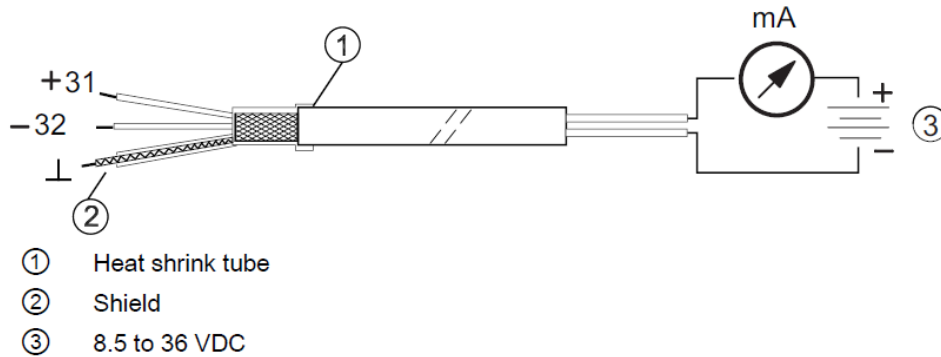

4. Tighten cable gland for current output cable (approx. 20 Nm).

## 5.6.3 Finishing connection

Mount the transmitter.

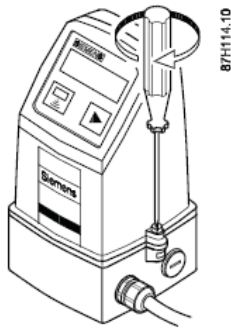

---

### Note

#### Grounding

To ensure identical potential for sensor and transmitter, a direct grounding of transmitter and sensor is recommended.

---

### Note

#### Aligning the gasket

Please ensure that the gasket between terminal box and transmitter is well aligned before tightening the screw (Min. torque 0.5 Nm).

---

## 5.7 Wiring energy calculator type INFOCAL 9

Energy calculator is typically connected via the pulse output A of the transmitter.

Wiring to flow meter SONO 3500 CT:

SONO 3500 CT in supply pipe	Infocal 9 terminal
56 (flow pulse)	10 (q1+)
57 (ground)	11 (q1-)

SONO 3500 CT in return pipe	Infocal 9 terminal
56 (flow pulse)	52 (q2+)
57 (ground)	11 (q2-)

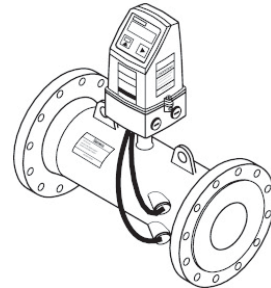

## 5.8 Sealing of SONO 3500 CT

### 5.8.1 User sealing

After finishing the installation and electrical connection, it is recommended to seal the flowmeter as shown. Drill through marked drilling holes in terminal box and transmitter/lid. Seal the transmitter on both sides with either one or two wires.

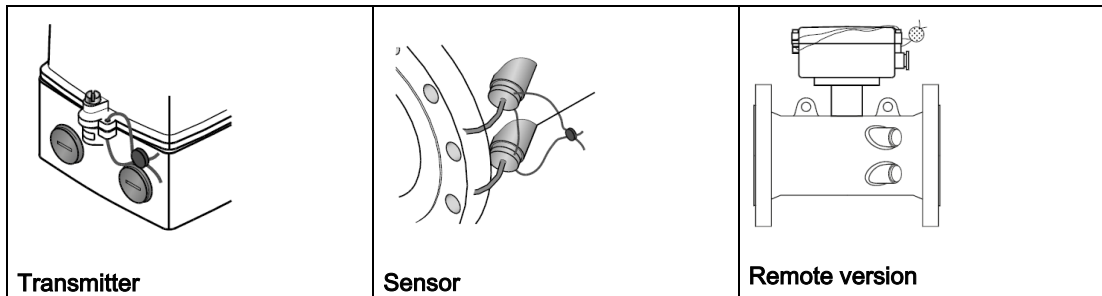

### 5.8.2 Verification sealing

This illustration shows how the device is verification sealed.

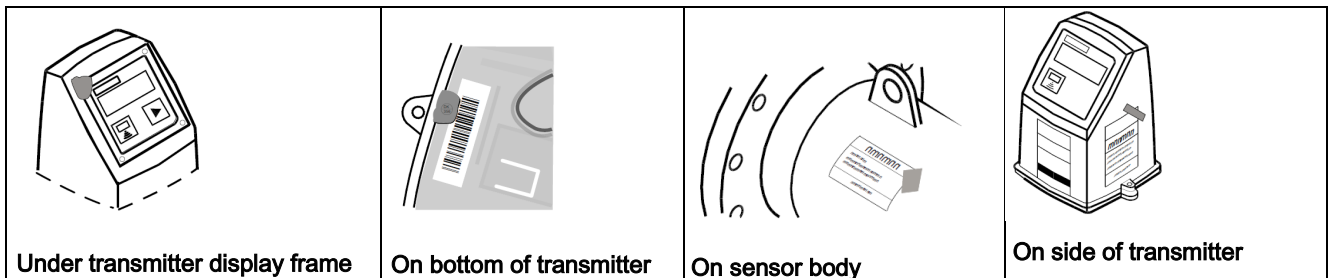

#### Note

#### For type-approved and verified SONO3500 CT flowmeters

The HW key is located behind the display and is thereby protected by the display sealing.

The verification sealing may only be broken with the acceptance of the local authorities.

## Commissioning

### 6.1 Introduction

Commissioning the device includes the following steps:

1. Resetting the battery lifetime (see Start-up routine (Page 41)).
2. Checking values in the service menu.
3. Configuring the device via SIMATIC PDM (see Commissioning via PDM (Page 42)).

It is recommended to read the basic guide to the local display and the menu structure in Operating the local display (Page 39) and Navigating the menu structure (Page 40) before commissioning the device.

### 6.2 Operating the local display

The local display is divided into 3 areas:

1. Top area with symbols for status information
2. Mid area with actual readings
3. Lower area with index number of the shown menu

Activate the push button to go the next index menu and related information.

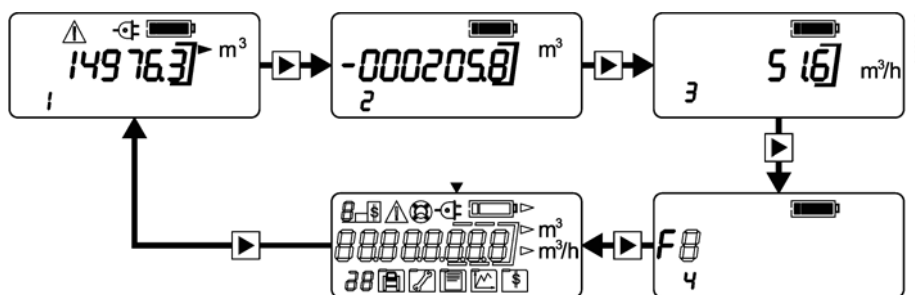

Figure 6-1 Operating the local display

Table 6-1 Status information symbols

Symbol	Description
	Mains power supply connected
	Battery charge status
	Warning
	Service menu

## Battery status

There are two symbols for battery charge status:

4. "Battery full" indicates battery charge above the warning level (6-year hour counter).
5. "Battery low" indicates battery charge below the warning level and that the battery should be replaced.

---



### Note

"Battery low" only indicates that battery charge is below a pre-set level, not that charge is zero.

Flow measurement continues uninterrupted until the battery is completely drained.

---

Table 6- 2 Battery status information symbols

Symbol	Description
	Battery status, full
	Battery status, low

## 6.3 Navigating the menu structure

Use the push button to navigate between the following menu items:

Table 6- 3 Menu items







Menu	Parameter	Display example	Comments
Menu 1	Flow volume totalizer 1		Factory preset is forward volume flow. The battery symbol shows full.
Menu 2	Flow volume totalizer 2		Factory preset for reverse flow. Negative values indicate reverse flow calculation.
Menu 3	Actual flow rate		Negative values indicate reverse flow calculation.
Menu 4	Alarm codes		Each code refers to a specific alarm.
Menu 5	Display test		Check of all segments. Display toggles between all segments on/off.

Table 6-4 Service menu

Menu	Parameter	Display example	Comments
	Service menu		The service menu is accessible from all menus by pressing push button for minimum 2 seconds. For more information on the complete service menu, see Service menu (Page 56).

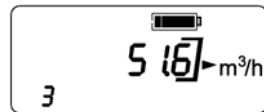
## 6.4 Start-up routine

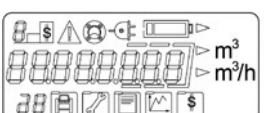
1. Power-up device.
2. Reset battery status indicator as described below.

### Resetting the battery counter

#### Note

The reset can also be carried out via SIMATIC PDM.

When a new battery is installed and the plug is connected, the transmitter start-up routine begins. The display shows the active software version, e.g. 2.04.

After ten seconds the message "reset.bat" will appear.

1. Press push button within six seconds to reset the internal battery counter. The message "accept" will appear.
2. Press push button again within six seconds in order to reset the internal battery counter. The battery indicator now shows full. If the push button is not pressed again, the battery indicator will show "Low".

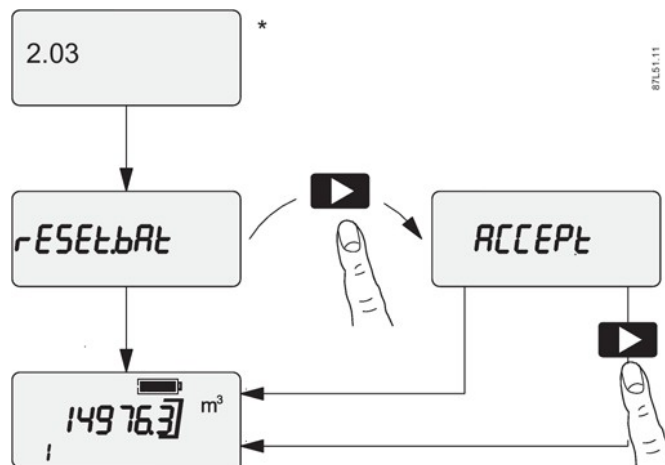

Figure 6-2 Reset internal battery counter

\* Firmware version, here version 2.03

## 6.5 Commissioning via PDM

SIMATIC PDM (Process Device Manager) is a software package for configuring, parameterizing, commissioning, and maintaining field devices (for example transducers).

Among other features, SIMATIC PDM contains a simple process for monitoring process values, interrupts and status/diagnosis signals of a field device.

---

### Note

For instructions on installation and operation of SIMATIC PDM, refer to the SIMATIC PDM Getting Started (included in the documentation package that comes with PDM).

---

### Note

PDM version required is SIMATIC PDM V6.1

---

### Note

#### Default password

Any data change in PDM requires a password. The default password is 1000. For further information, see Password-protected data (Page 51).

---

### Note

For type-approved and verified SONO 3500 CT flowmeter the settings are HW key protected and can only be read, but not changed via PDM. This HW key is protected via the verification sealing. The verification sealing can only be broken by the user with the acceptance of the local authorities.

---

In the following it is described how the device is commissioned using SIMATIC PDM.

The commissioning is divided into the following steps:

1. Installing and connecting the IrDA interface adapter (Page 43)
2. Installing EDD files (Page 43)
3. Adding the device to the network (Page 44)
4. Configuring the device (Page 44)
5. Optimizing the system (Page 46)
6. Checking the operation readiness (Page 48)

## 6.5.1 Installing and connecting the IrDA interface adapter

---

### Note

#### IrDA driver installation

For installation of the IrDA driver, refer to the instructions delivered with the adapter.

---

1. Connect IrDA adapter to PC

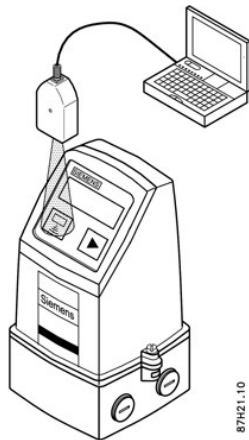

2. Mount adapter on the transmitter

When the IrDA adapter is connected correctly, a small icon appears on the taskbar of your PC. When the mouse is placed on this icon, the device information will be shown (e.g. "SN1033 is in range").



## 6.5.2 Installing EDD files

Install the PDM device driver as follows:

1. Download update from the Internet on <http://www.danfoss.com>. ([www.danfoss.com](http://www.danfoss.com))  
Check that the EDD (electronic device descriptions) is the version valid for the device.
2. Open "Manage Device Catalog" from Start → SIMATIC → SIMATIC PDM.
3. Navigate to PDM device driver, select device and click "OK". The driver is installed on the PC.

### 6.5.3 Adding the device to the network

It is recommended to configure the project in PDM before setting the parameters.

Add device to SIMATIC Modbus network:

1. Select [File → New]  
Type in a project name, e.g. SONO 3500 CT
2. Right click on your new project, select [Insert New Object → Networks].
3. Right click on your Networks, select [Insert New Object → Communication Network].
4. Click on [Assign Device Type] and select Networks → MODBUS → MODBUS networks → MODBUS network.

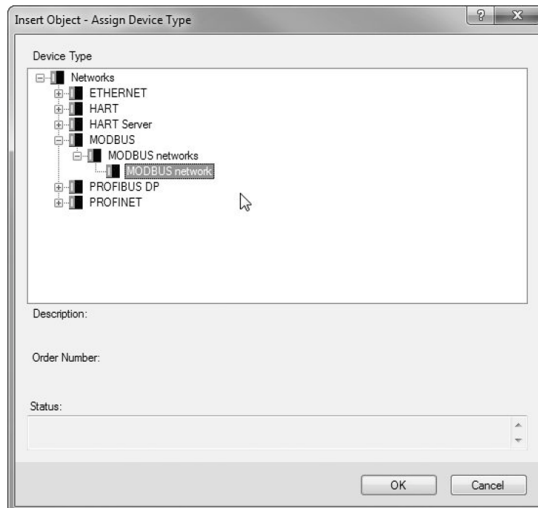

5. Click [OK] and click [OK] again.
6. Right click on MODBUS network and select [Insert New Object → Object]
7. Click on [Assign Device Type] and assign the MODBUS device to SITRANS FUS/E080 [Devices → MODBUS → Sensors → Flow → Ultrasonic → SIEMENS AG → SITRANS FUS/ E080] and click [OK].  
Name device according to application requirements (max. 32 characters) and click [OK].  
Set up communication parameters for SIMATIC MODBUS network.
8. Select Networks → MODBUS network.
9. Right click on Modbus network and select Object Properties.
10. On the Communication tab, select MODBUS communication to activate IrDA.

### 6.5.4 Configuring the device

In the following it is described how to configure the device by defining all sensor specific parameters.

---

#### Note

#### Measurement accuracy

A correct flowmeter installation is required to ensure optimum measurement accuracy.

---

## Read all parameters

Before any parameterization is done it is necessary to read all parameters from the device into the offline table of SIMATIC PDM. The offline table merely contains default data.

1. Open PDM device driver.
2. Select "Upload to PC/PG .." Select "Execute even if the device TAG does not match the project data TAG.", and click "OK" to read all parameters to the offline table. After closing the dialog box, all loaded parameters should show "Loaded" in the status of the PDM table. For a complete parameter list, see Parameter lists (Page 73).
3. Store factory set default values on your local PC ("File" → "Export") in order to be able to retrieve default settings.

## Read, write device data

Only parameters (data) shown with white background can be changed.

### Note

#### Status field

- "Changed" indicates off-line data not yet stored in the device.
- "Loaded" indicates actual device data.

Parameter	Value	Unit	Status
<b>SITRANS FUS080</b>			
DD-Version	01.02.07		Initial value
<b>» Identification</b>			
1 Application identifier	Identity		Loaded
2 Application location	Location		Loaded
<b>» » Device</b>			
5 Sensor size	DN200		Loaded
8 Totalizer unit	m3		Loaded
9 Flowrate unit	m3/h		Loaded
10 Qmax (105% of Qs)	399,000000	m3/h	Loaded
373 Low flow cut-off	0,250000	%	Loaded
20 Vendor name	SIEMENS A/S		Loaded
21 Module type	SONOKIT/FUS880		Loaded
22 Software version	2.03		Loaded
23 Product code number	7ME32202FA111VA1		Loaded
24 System Serial number	000000N000		Loaded
25 Transmitter serial number			Loaded
505 Device Product ID	Vendor id: 042; Product id: 028		Loaded
<b>» Output</b>			
<b>» » Operation</b>			
100 Actual date and time	15-08-2011 07:23:10		Loaded
101 Totalizer 1	0,444444	m3	Loaded
102 Totalizer 2	0,000000	m3	Loaded
103 Customer totalizer 3	0,444444	m3	Loaded
104 Reset customer totalizer 3	No		Loaded
105 Customer totalizer 3 reset date	18-03-2011 10:18:08		Loaded
106 Flow rate	0,000000	m3/h	Loaded
107 Relative flow rate	0	%	Loaded
108 Actual velocity for track 1	0	m/s	Loaded
109 Actual velocity for track 2	0	m/s	Loaded
110 Track 1 gain step	15		Loaded
111 Track 2 gain step	15		Loaded

To view possible settings, right-click and select "Help".

## 6.5.5 Optimizing the system

After storage of the settings, the parameters can be set according to use.

The following shows how to set Pulse Output A and Qmax. For other parameters, refer to "Parameter list" in the appendix.

### Setting Pulse Output and Maximum Flow ( $Q_{max}$ ) via SIMATIC PDM

1. In SIMATIC PDM navigate to menu "Device" → "Pulse guide"  
The "guide" calculates the pulse-frequency at the max flow condition and tells you how close you are on over-speeding the pulse-output.  
The volume per pulse is freely scalable from 0.000001 to 10000 units per pulse. It also calculates the minimum volume per pulse you can choose to avoid pulse over-speeding.  
The maximum output frequency depends on the pulse selected; e.g. maximum output frequency at 5 ms is 100 Hz. Increasing the pulse width lowers the maximum output frequency.
2. Select maximum flow rate (never to be exceeded).
3. Select an appropriate pulse width, e.g. 5 ms.
4. Enter a value in "Amount per pulse A", e.g. 100, to define the volume/pulse with respect to the "Minimum amount per pulse value".
5. Press "Apply Change of Pulse" to apply the settings.
6. If needed, proceed with setting Pulse Output B according to application specific requirements (Default setting = Alarm).

### Output A and B setting

For SONO 3500 CT, output A and B settings depend on the ordering: Recommended settings, see the following table. The SONO 3500 CT settings cannot be changed according approval requirements, and are therefore read only.

	SONO 3500 CT
Output A	Forward or reverse pulses Preset: Forward
Output B	Forward or reverse pulses, alarm, call-up Preset: Alarm
Pulse value A & B (depending on DN value)	Preset: See scheme for SONO 3500 CT or the following settings for INFOCAL 9 energy calculator.
Pulse width	Preset: 5 ms

---

#### Note

For type-approved and verified SONO 3500 CT flowmeter the settings are HW key protected and therefore read only. This HW key is protected via the verification sealing. The verification sealing can only be broken by the user with the acceptance of the local authorities.

---

## 6.5.6 Output A, terminals 56/57:

Pulse rate can be seen on transmitter side label (system nameplate).

The settings are depending on the ordering. The following table shows the recommended pulse output settings (pulse width 5 ms), which can be adapted to heat calculator INFOCAL 9.

DN	Pulse setting (liter/pulse)
100	2.5
125	2.5
150	2.5
200	10
250	10
300	10
350	10
400	50
500	50
600	100
700	100
800	100
900	100
1000	100
1200	100

---

### Note

For use with a energy calculator the pulse value must correspond to pulse setting of energy calculator.

---

## 6.5.7 Output B, terminals 66/67:

The output B setting must be selected according to application specific requirements (Default setting = Alarm).

### Preset to alarm indication:

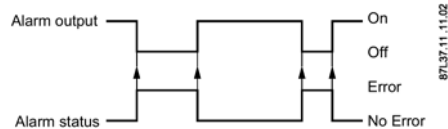

Example: If track 1 is not measuring, a "triangle" alert appears on display. Failure code "F1" appears in display menu 4, and relay output terminals switch to "off".

### Call up indication:

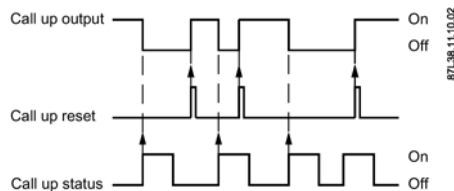

When output B is configured as "call-up", the output is activated by an alarm condition and remains on until it is manually reset via communication interface and the PDM program (or via manually power down of the device).

A new alarm will not activate a "call-up" function if the "call-up" function is still active from a previous alarm.

## 6.5.8 Checking the operation readiness

All parameters are now set and defined according to the application.

1. Select: "Device" → "Download to device..." to download the parameters to the device.

---

### Note

Before downloading the parameters, check that all listed data are loaded or changed and in accordance with the application requirements.

---

2. Select "Execute even if the device TAG does not match the project data TAG." and click "OK" to download all changes from the table to the device.

## View process values

The system is now ready for normal operation.

1. Select "View" → "Display" to see all measured process values.
2. Verify that the fields show the expected values.

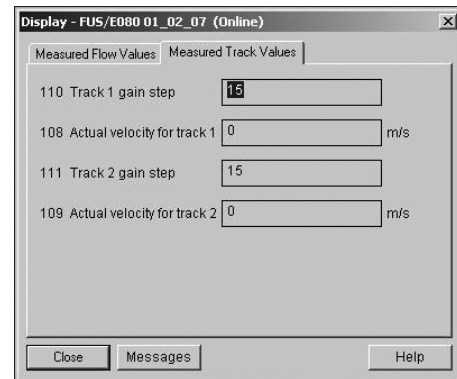
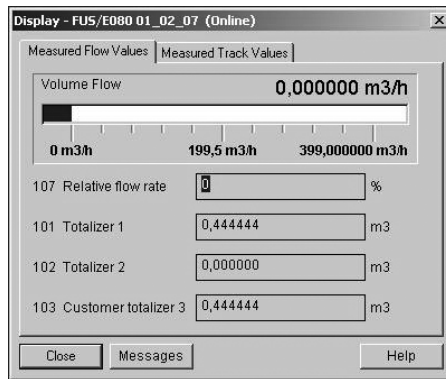

---

### Note

#### Measured Track Values

The "Measured Track Values" should show stable values within the normal range, i.e. the gains should be stable values between 3 and 12 (smaller sizes low values and larger sizes high values) and the actual velocities for the paths should be stable, constant and smoothly changing values between 0 and 10 m/s.

---

## Store settings on the PC

Store the device settings after verifying the values.

- Choose: "Read" → "Upload to PC" to get all the settings.
- Store the complete settings on your PC via "File" → "Export".

## Functions

### 7.1 Unit selection

The device is delivered with totalizer and flow rate units in m and m<sup>3</sup>/h, respectively, as standard. However, it is possible to manually configure the device to operate with other units.

#### Changing the units

Go via PDM menu "Device" → "Unit guide". Select the new unit from the list and click on "Apply Change of Units". The change should be stored into the transmitter via "Device" → "Download to Device" afterwards.

Figure 7-1 Unit selection

#### Note

The display is only able to show m<sup>3</sup> and m<sup>3</sup>/h

If the units are changed to units other than m<sup>3</sup> and m<sup>3</sup>/h, the display will not show any unit indication after the measured value on the display. To show the new customer unit on the display, a sticker can be used to show units. This sticker should be affixed to the transmitter display.

### 7.2 Number of decimal digits

For the display values (totalizers in menu 1 and 2 and flow in menu 3) "Auto adjust decimal point" is the default setting. This means that the number of digits after the decimal point automatically will be reduced with increasing number of digits before the decimal point.

## 7.3 Password-protected data

In the MODBUS communication via SIMATIC PDM, the flowmeter information is protected by a password. The default password is "1000" and it can be changed after gaining access to the flowmeter or via the PDM menu "Device" → "Change Password". **The password can be changed without the use of the HW key.**

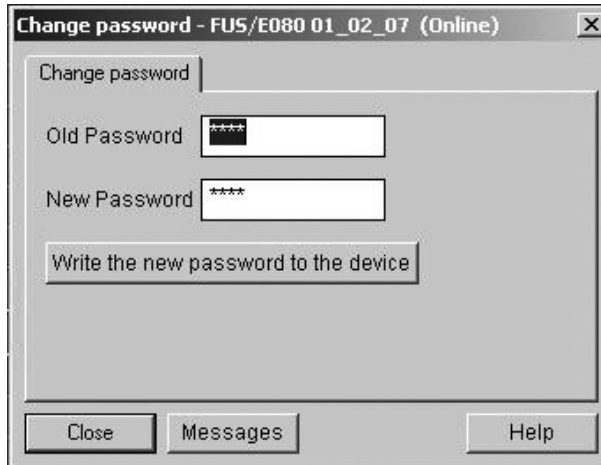

Figure 7-2 Change password

Click "Write new password to the device" and "Close"

## 7.4 Hardware key

To gain access to protected parameters of the transmitter, a hard-ware jumper (HW key) must be installed as shown below. The HW key place is located internally on the right top part of PCB behind the display as shown.

---

### Note

For type-approved and verified SONO 3500 CT flowmeter the HW key is protected by a verification sealing on the display frame (see Sealing of SONO 3500 CT (Page 38)). The verification sealing can only be broken by the user with the acceptance of local authorities.

---



Figure 7-3 HW key behind the display (placed on the right pins)

---

**Note**

**Important**

In this mode, with the HW key installed, many parameters in PDM are opened. If these parameters are changed, it can seriously affect the meter accuracy and operation. Be careful when writing new parameters.

---

### Changing the HW-protected parameters

1. Disconnect power supply to transmitter, i.e. battery plug and the mains power supply
2. Remove frame and display from transmitter.
3. Insert HW key vertically on right pins as shown in figure above.
4. Remount display and frame on transmitter.
5. Restart device.
6. Make parameter changes via PDM.
7. Download parameter changes to device.
8. Remove HW key by following the steps above.

## Service and maintenance

### 8.1 Maintenance

The device is maintenance-free. However, a periodic inspection according to pertinent directives and regulations must be carried out.

An inspection can include check of:

- Ambient conditions
- Seal integrity of the process connections, cable entries, and cover screws
- Reliability of power supply, lightning protection, and grounds

<b>NOTICE</b>
<b>Repair and service</b> Repair and service must be carried out by Danfoss authorized personnel only.

**Note**

The flow sensors are defined as non-repairable products.

### 8.2 Battery replacement

<b>NOTICE</b>
<b>Battery replacement interval</b> It is recommended to replace the battery pack at the latest after 6 years.

## Battery lifetime

The battery lifetime depends on the frequency of mains supply failure. Under normal temperature and working conditions a battery can have an operation lifetime up to 6 years.

1. Unscrew battery cover and remove old battery pack.

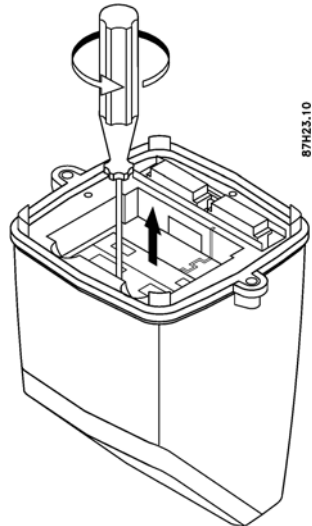

2. Fit new battery pack in transmitter.

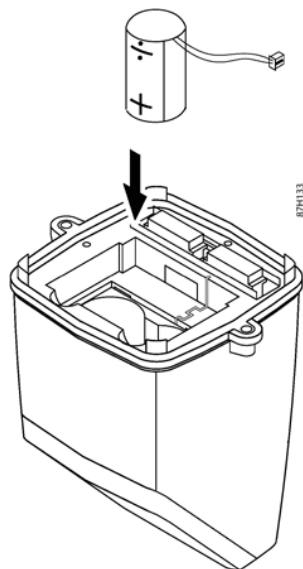

3. Connect battery.  
Ensure that wire is inserted into small channel leading from plug to battery.

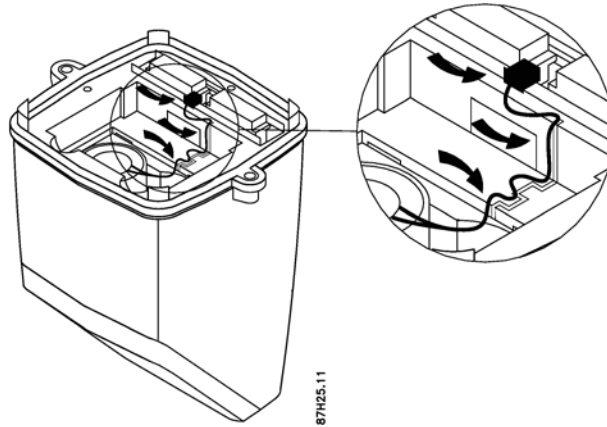

4. Remount battery cover.

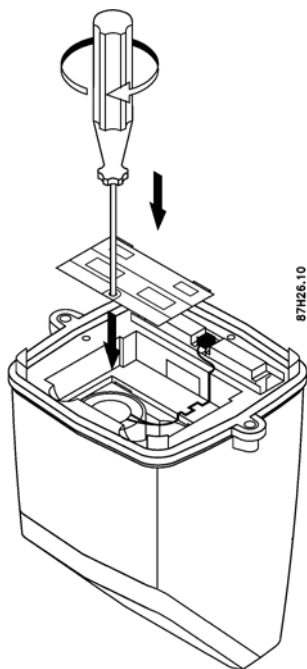

---

**Note**

Every time a battery is fitted and connected, the unit runs a start-up routine.

A battery replacement does not influence the transmitter settings and accumulated process values.

---

## Resetting the internal battery counter

After replacing the batteries, reset the internal battery counter in order to indicate the power capacity correctly.

### Note

#### Battery capacity

The transmitter setting for the battery capacity is pre-configured by the ordered version. To ensure the correct battery status calculation the replacement battery shall be the same type and have the specific capacity. The capacity setting can be controlled via SIMATIC PDM.

## 8.3 Service menu









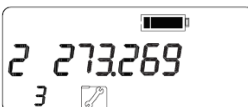

The service menu () is accessible from all menus by pressing the push button for minimum 2 seconds. To return back to the main menu you need to press the push button for a minimum of 2 seconds again. If no action is taken you will be taken back to the main menu after 10 min if back-up battery powered or after 2 min if mains-powered.

Table 8-1 Service menu

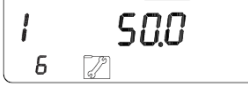
Menu	Parameter	Display example	Comments
1	Gain path 1 and path 2		Gain for path 1 and path 2 ranging from 0 to 15. The optimal gain values are explained in Figure 9-2 SI- TRANS FUS080 Gain step vs. Sensor distance (Page 66).
2	Signal level AB and BA of path 1		Signal level for Downstream and Upstream Sensor for path 1 typically between 230 and 380
3	Signal level AB and BA of path 2		Signal level for Downstream and Upstream Sensor for path 2 typically between 230 and 380
4	Transition time (µs) AB of path 1		Time of Flight Downstream, from Sensor A to B for path 1
5	Transition time (µs) AB of path 2		Time of Flight Downstream, from Sensor A to B for path 2
6	Transition time (µs) BA of path 1		Time of Flight Upstream, from Sensor B to A for path 1

Menu	Parameter	Display example	Comments
7	Transition time ( $\mu$ s) BA of path 2		Time of Flight Upstream from Sensor B to A for path 2
8	Delta time (ns) of path 1		Delta Time Of Flight for path 1, difference between Down and up-stream TOF Positive value equals positive flow
9	Delta time (ns) of path 2		Delta Time Of Flight for path 2, difference between Down and up-stream TOF Positive value equals positive flow
10	Velocity (m/s) path 1		Measured flow velocity for path 1
11	Velocity (m/s) path 2		Measured flow velocity for path 2

## See also

Optional current output module (Page 35)

## 8.4 Technical support

### Additional Support

Contact your local Danfoss representative and offices if you have additional questions about the device.

Find your local contact partner at: [www.danfoss.com](http://www.danfoss.com) ([www.danfoss.com](http://www.danfoss.com))

## 8.5 Application-specific data - Qualification certificate

In case the device needs service, the technical support team will typically request information about the application and the flowmeter.

- Prepare a sketch of the installation/application.
- For your convenience you may create a qualification certificate via SIMATIC PDM

1. In PDM click on "Device" → "Qualification Certificate".

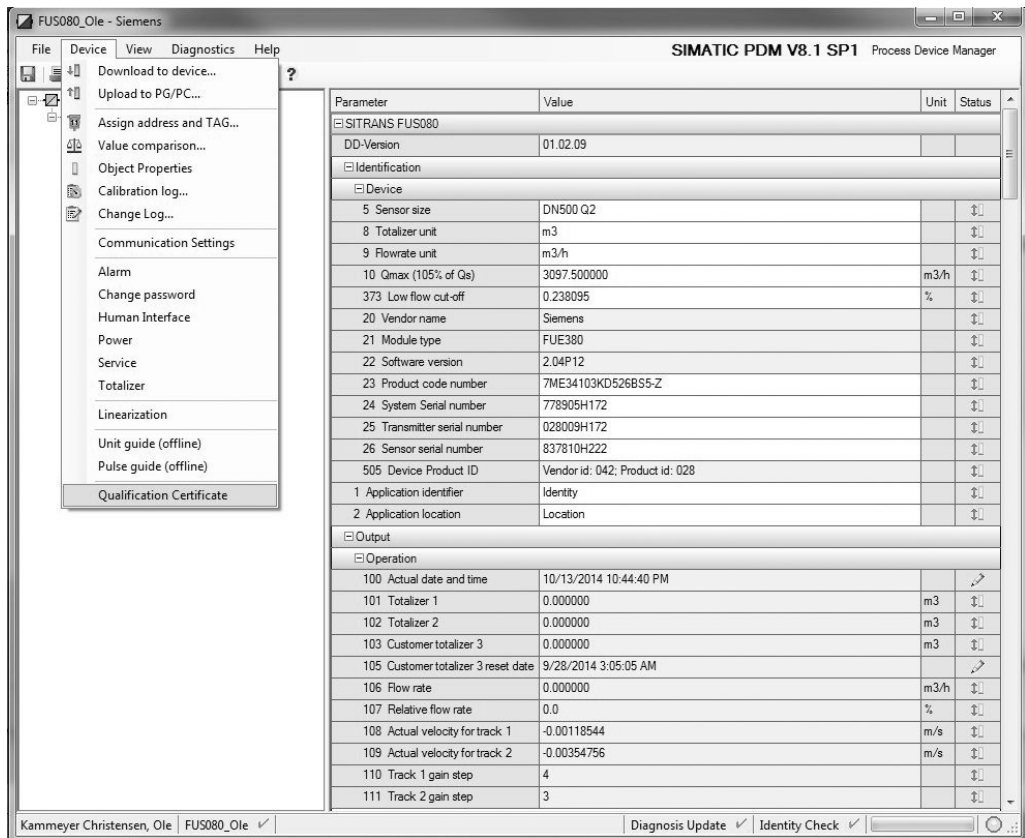

2. Click on "Generate qualification certificate".

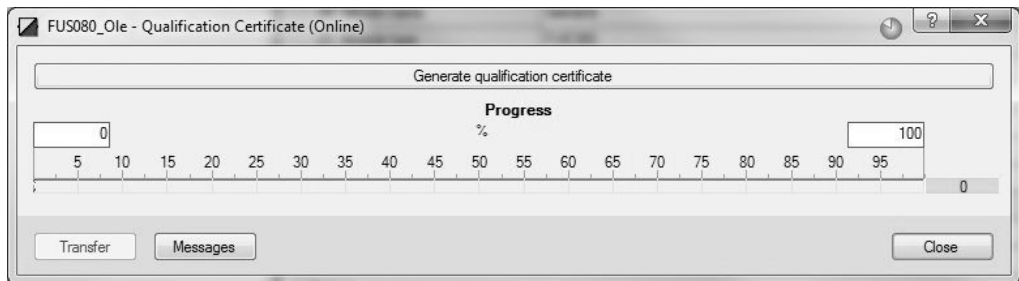

3. Click on "Close".

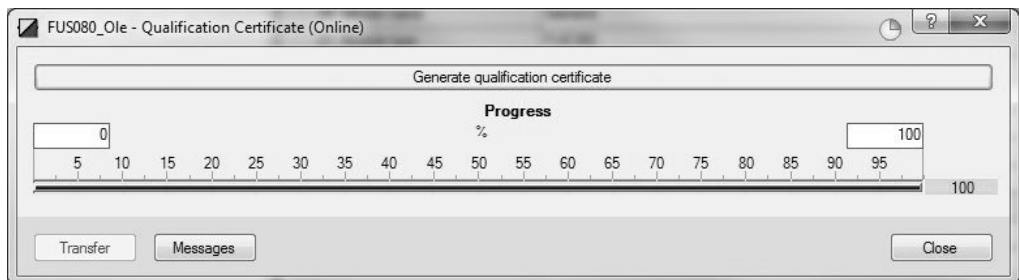

The Qualification Certificate is now available via Microsoft Word. In it add the required application information (see Figure 8-1 Qualification certificate - page 1 (Page 59), Figure 8-2 Qualification certificate - page 2 (Page 60) and Figure 8-3 Qualification certificate - page 3 (Page 61)).

## 8.6 Qualification certificate

### Qualification Certificate

### SONO 3500 CT based flowmeter

Please upload the data of the FUS/E080 transmitter via IrDA and PC adapter by using the software tool SIMATIC PDM (PDM = Process Device Manager). The data will be automatically uploaded into this report. The information of the transmitter system label should be noted also. A print of the uploaded parameter list (e.g. as PDF-format) should be added to this certificate and also a copy of the original calibration certificate (if available).

The help tools are: PDM 6ES7658-3HX06-0YA5, PC adapter FDK-087L4163 and IrDA-holder A5E00695277; please contact for it your local Siemens Company.

<p><b><u>Application / Customer:</u></b></p> <p>Name _____          Address _____          _____          Phone _____          Email _____</p> <p>Measured liquid:           Water          Process temperature:    Min. _____ °C                                            Max. _____ °C</p>	<p><b><u>Transmitter Identification</u></b></p> <p>Type (module type): SONOKIT/FUS880          SW Version:           7ME3411-2HC32-4ER2          Product Code No.:    7ME32202FA111VA1          Product Code No.:    _____ (transm. label)          System Serial No.:    000000N000          System Serial No.:    _____ (transm. label)          System Serial No.:    _____ (sensor label)</p> <p>The PDM- and label data must be the same:          Passed :               (Date and signature)  <input type="checkbox"/> Yes <input type="checkbox"/> No <input style="width: 100px;" type="text"/></p>
<p><b><u>General System Settings</u></b></p> <p>Qmax:                     399 m3/h          Low flow cut-off:     0,25 per cent of Qmax</p> <p>Settings of transmitter label:          Qi, Qmin:             _____ m3/h (transmitter label)          Qp, Qnom:             _____ m3/h (transmitter label)          Qs, Qmax:             _____ m3/h (transmitter label)</p> <p>Transducer cable length: 15 m          Transducer cable length: _____ m (used length +/- 0.5 m)</p> <p>Calibration factor:    1          Calibration factor:    _____ (transmitter label)          Adjustment factor:    1           (should be 1.0)</p> <p>The PDM-, label and data must be the same:          Passed :               (Date and signature)  <input type="checkbox"/> Yes <input type="checkbox"/> No <input style="width: 100px;" type="text"/></p>	<p><b><u>Sensor Details</u></b></p> <p>Sensor size:            DN200          Pipe diameter:         0,2031 m          No. of tracks:         2          Rn of track 1:         0,4603736          Rn of track 2:         0,4603736</p> <p>Sensor check: Is the installation and the sensor ok?          Passed :               (Date and signature)  <input type="checkbox"/> Yes <input type="checkbox"/> No <input style="width: 100px;" type="text"/></p>

Figure 8-1 Qualification certificate - page 1

# Qualification Certificate

# SONO 3500 CT based flowmeter

<p><b><u>Totalizer values</u></b></p> <p>Totalizer 1:           0,4444444 m3          Totalizer 2:           0 m3          Customer Totalizer 3: 0,4444444 m3</p> <p>Customer Totalizer 3 reset: 18-03-2011 10:18:08</p> <p>Customer Totalizer 3 reset done:          (Date and signature)  <input type="checkbox"/> Yes <input type="checkbox"/> No <input style="width: 150px;" type="text"/></p>	<p><b><u>Power Supply Status</u></b></p> <p>Power supply:           Battery only          Battery installation date: 18-03-2011 10:06:04          Battery consumed power: 2,049692 Ah          Battery capacity:       25 Ah          (12.5 Ah single bat. or 25 Ah double pack bat.)          Battery alarm limit:    80 per cent</p> <p>Battery change and capacity calculation reset done:          (Date and signature)  <input type="checkbox"/> Yes <input type="checkbox"/> No <input style="width: 150px;" type="text"/></p>
---------------------------------------------------------------------------------------------------------------------------------------------------------------------------------------------------------------------------------------------------------------------------------------------------------------------------------------------------------------------------------------------------------------------	------------------------------------------------------------------------------------------------------------------------------------------------------------------------------------------------------------------------------------------------------------------------------------------------------------------------------------------------------------------------------------------------------------------------------------------------------------------------------------------------------------------------------------------------------------------

<p><b><u>Transmitter output A (pulse output)</u></b></p> <p>Output enable:       Yes          Pulse direction:     Forward          Amount per pulse:   1 m3          Pulse width:         5 ms</p> <p>Amount per pulse:    _____ m3 (transmitter label)          Pulse width:         _____ ms (transmitter label)</p> <p>The PDM- and label must be the same:          Passed :            (Date and signature)  <input type="checkbox"/> Yes <input type="checkbox"/> No <input style="width: 150px;" type="text"/></p>	<p><b><u>Transmitter output B</u></b></p> <p>Output enable:       Yes          Output function:     Alarm          Pulse direction:     _____ (pulse function only)          Amount per pulse:    _____ (pulse function only)          Pulse width:         _____ (pulse function only)</p> <p>Amount per pulse:    _____ m3 (transmitter label)          Pulse width:         _____ ms (transmitter label)</p> <p>The PDM- and label must be the same:          Passed :            (Date and signature)  <input type="checkbox"/> Yes <input type="checkbox"/> No <input style="width: 150px;" type="text"/></p>
----------------------------------------------------------------------------------------------------------------------------------------------------------------------------------------------------------------------------------------------------------------------------------------------------------------------------------------------------------------------------------------------------------------------------------------------------------------------------------------------------------------------------------------------------	------------------------------------------------------------------------------------------------------------------------------------------------------------------------------------------------------------------------------------------------------------------------------------------------------------------------------------------------------------------------------------------------------------------------------------------------------------------------------------------------------------------------------------------------------------------------------------------------------------------------------------------------

<p><b><u>Measurement Function, Operation and Diagnostic:</u></b></p> <p>Flow rate:            0 m3/h          Flow rate:            _____ m3/h (transm. display)          Relative flow rate:   0 per cent of Qmax          (must be below 100)</p> <p>Actual velocity track 1: 0 m/s          Actual velocity track 2: 0 m/s          (values must be the same for both tracks, +/- 0.05 m/s ok)</p> <p>Track 1 gain step:     15          Track 2 gain step:     15          (values must be the same for both tracks, +/- 1 ok)          (good between 1 – 8, typical 3 – 5, depends on pipe size.          If &gt; 8, then it is not ok and max. bad value is 15)</p> <p>Passed :            (Date and signature)  <input type="checkbox"/> Yes <input type="checkbox"/> No <input style="width: 150px;" type="text"/></p>	<p><b><u>Faults / Alarms</u></b></p> <p>Transmitter fault status:    Faults: 1 2</p> <p>Alarm / faults or warnings on the display?:  <input type="checkbox"/> Yes <input type="checkbox"/> No</p> <p>If yes, which are shown:  <input type="checkbox"/> F1 <input type="checkbox"/> F2 <input type="checkbox"/> F3 <input type="checkbox"/> F4 <input type="checkbox"/> F5 <input type="checkbox"/> F6 <input type="checkbox"/> F7 <input type="checkbox"/> F8 <input type="checkbox"/> F9</p> <p>Passed :            (Date and signature)  <input type="checkbox"/> Yes <input type="checkbox"/> No <input style="width: 150px;" type="text"/></p>
------------------------------------------------------------------------------------------------------------------------------------------------------------------------------------------------------------------------------------------------------------------------------------------------------------------------------------------------------------------------------------------------------------------------------------------------------------------------------------------------------------------------------------------------------------------------------------------------------------------------------------------------------------------------------------------------------------------------------------------------------------------------------------------------------------------------------------------------------------------------	-----------------------------------------------------------------------------------------------------------------------------------------------------------------------------------------------------------------------------------------------------------------------------------------------------------------------------------------------------------------------------------------------------------------------------------------------------------------------------------------------------------------------------------------------------------------------------------------------------------------------------------------------------------------

Figure 8-2 Qualification certificate - page 2

# Qualification Certificate

# SONO 3500 CT based flowmeter

<p><b>Service / Diagnostic</b></p> <p>Fixed flow mode enable: No Fixed flow value: 100 m3/h (max. allowed value is Qmax = 399 m3/h)</p> <p>Output A controlling Auto Output B controlling Auto</p> <p>Check: The fixed flow must be 'No' and outputs 'Auto'.</p> <p>Passed : (Date and signature) <input type="checkbox"/> Yes <input type="checkbox"/> No <input type="text"/></p>	
-----------------------------------------------------------------------------------------------------------------------------------------------------------------------------------------------------------------------------------------------------------------------------------------------------------------------------------------------------------------------------------------------------	--

<p><b>Comments</b></p> <hr/> <hr/> <hr/> <hr/> <hr/>
------------------------------------------------------

Complete Qualification Passed:  Yes  No

The values were verified of (name) \_\_\_\_\_

Date and signature \_\_\_\_\_

Figure 8-3 Qualification certificate - page 3

## 8.7 Return procedures

Enclose the delivery note, the cover note for return delivery together with the declaration of decontamination form on the outside of the package in a well-fastened clear document pouch.

## Required forms

- **Delivery Note**
- **Cover Note for Return Delivery** with the following information
  - product (ordering number)
  - number of devices or spare parts returned
  - reason for the return
- **Declaration of Decontamination**

With this declaration you certify *that the returned products/spare parts have been carefully cleaned and are free from any residues.*

If the device has been operated together with toxic, caustic, flammable or water-damaging products, clean the device before return by rinsing or neutralizing. Ensure that all cavities are free from dangerous substances. Then, double-check the device to ensure the cleaning is completed.

We will not service a device or spare part unless the declaration of decontamination confirms proper decontamination of the device or spare part. Shipments without a declaration of decontamination will be cleaned professionally at your expense before further proceeding.

You can find the forms on the Internet.

---

### Note

#### Return of products with Lithium batteries

Lithium batteries are certified as dangerous goods according to the Regulation of Dangerous Goods, UN 3090 and UN 3091. Special transport documentation is required to observe these regulations.

Therefore it is recommended to remove lithium batteries prior to shipment.

If the battery is important for the examination of the product and it cannot be removed, the product has to be returned according to the Regulation of Dangerous goods.

---

## 8.8

### Battery disposal



In accordance with EU directive 2006/66/EC, batteries are not to be disposed of using municipal waste disposal services.

Waste industrial batteries are accepted back by Danfoss or by the local Danfoss representative. Talk to your local Danfoss contact or follow the return procedures of Danfoss

## Troubleshooting/FAQs

### 9.1 Error codes

A list of errors is available in SIMATIC PDM (active errors are check-marked). Access to this list is gained via "Device" → "Device Status". In the figure below, error codes F 1, F 2 and F 5 are active.

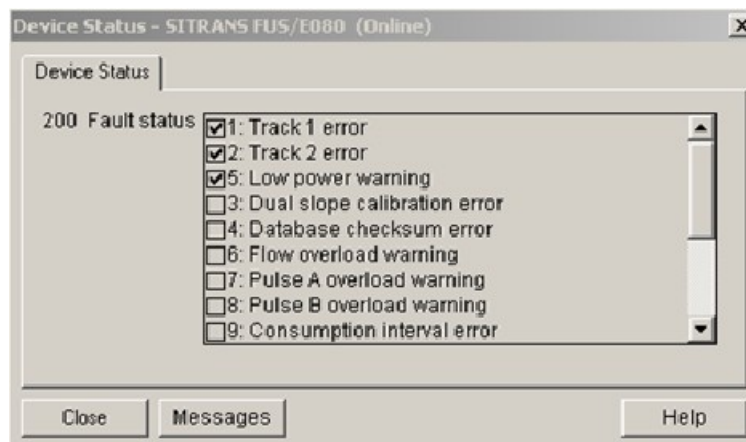

Figure 9-1 List of errors shown in PDM

Table 9- 1 Error codes shown in the display and in PDM

Error code	Error	Remedy/Cause
Blank display	Battery plug not connected, or battery empty, mains power interrupted	<ul style="list-style-type: none"> <li>Check flowmeter version. Battery version not able to run on mains power</li> <li>Battery empty: Replace battery pack</li> <li>Battery plug not plugged into the transmitter, see Battery replacement (Page 53)</li> </ul>
F 1	Path 1 (upper path) not measuring	No water in upper part of pipe and/or cables or transducer 1A or 1B defective
F 2	Path 2 (lower path) not measuring	No water in lower part of pipe and/or cables or transducer 2A or 2B defective
F 3	Internal software failure	Contact your customer support
F 4	Internal software failure	Contact your customer support
F 5	Power supply warning	<ul style="list-style-type: none"> <li>Mains power fails</li> <li>Replace battery pack</li> </ul>
F 6	Flow exceeds preset flow rate in unit (max. speed 10 m/s)	Flowrate too high
F 7	Pulse output A overflow	Pulse output exceeds 100 Hz or 50% duty cycle

Error code	Error	Remedy/Cause
F 8	Pulse output B overflow	Pulse output exceeds 100 Hz or 50% duty cycle
F 9	Datalogger warning/alarm	Datalogger warning monitors whether actual consumption on Totalizer 1 is on end of log interval or above/below the limit settings. The warning has no influence on the flowmetering. Check data logger values and consumption limit (via PDM parameter 602)

Errors "F 1" to "F 4" affect the performance of the meter and the flowmeter may stop measuring.

Errors "F 1" and "F 2" disappear when the alarm condition is corrected.

Errors "F 5" to "F 9" are only warnings and do not affect the measurement, but they will influence the outputs.

The error indications disappear when the alarm conditions are corrected and a reset via the communication interface has been carried out.

## Example

Error code "F 1 2" in the display indicates a combination of error codes "F 1" and "F 2".

Possible causes:

- Empty pipe
- Path 1 and path 2 cables defective
- Path 1 and path 2 cables not connected
- Transducers defective

## 9.2 Diagnosing with PDM

SIMATIC PDM is a suitable tool for diagnosing the device. You can use SIMATIC PDM to read all parameters available in the transmitter to a table for analyzing offline, view online/actual process values and online/actual diagnostic information.

### Requirements

The following procedure must be completed before diagnosing:

- Connection of Modbus interface via PC and IrDA, see Commissioning via PDM (Page 42)
- Installation of PDM and transmitter PDM driver, see Installing EDD files (Page 43)

## Diagnosing with PDM

Online process values are available under menu "View" → "Display".

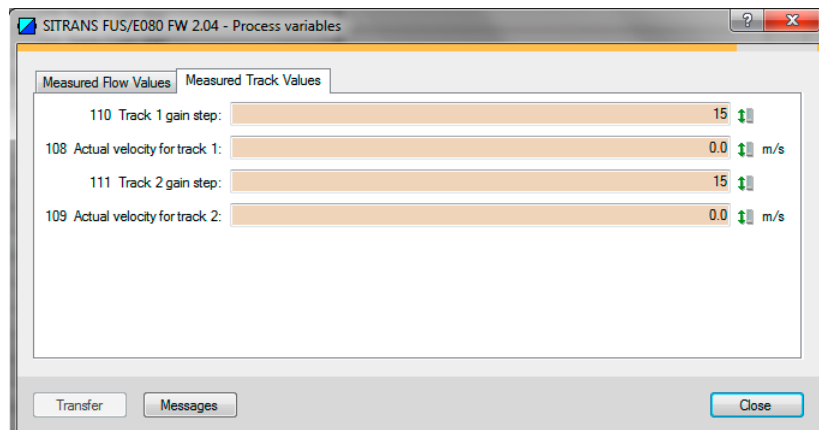
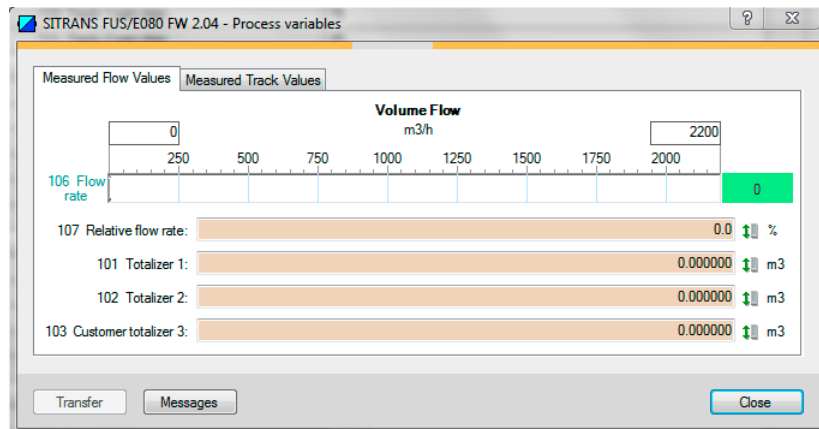

The "Measured Track Values" tab shows the gain steps and the flow velocities for path 1 and path 2. For 1-path applications the values for path 2 (track 2) are "0".

The gain steps depend on the pipe size and the conditions of the measuring media.

The flow velocities depend on the flow in the pipe.

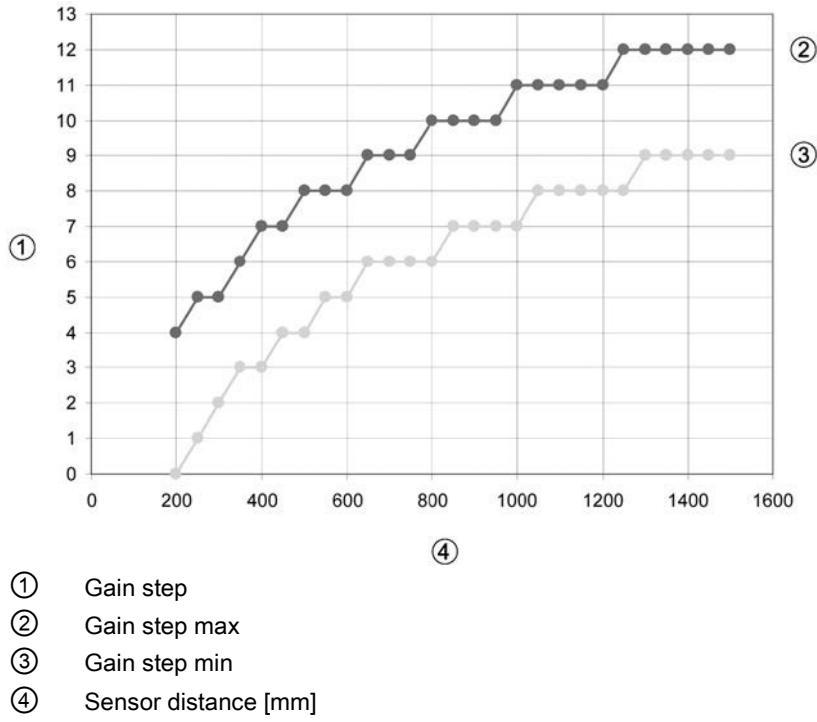

Figure 9-2 Transmitter gain step vs. Sensor distance

### Gain step

The graph above shows which gain step to expect for a particular transducer distance (face to face distance). The upper curve indicates the upper limit and the lower curve indicates the lower limit.

The graph applies to perfectly aligned transducers in clean water, but takes into account the expected variance from the converter and the transducers.

### Gain step error conditions

Condition	Cause
15	<ul style="list-style-type: none"> <li>No transducer (e.g. defective cable)</li> <li>Empty pipe</li> </ul>
High values	<ul style="list-style-type: none"> <li>High damping (e.g. inhomogeneous media)</li> <li>Unsuitable medium</li> <li>Path angular misalignment</li> </ul>
Unstable/fluctuating values	<ul style="list-style-type: none"> <li>Air bubbles or solids in medium</li> <li>Bad inlet conditions</li> </ul>
$\Delta$ gain step between path 1 and path 2 > 1 (2-path systems only)	<ul style="list-style-type: none"> <li>Bad inlet conditions</li> <li>Inhomogeneous medium</li> <li>Path angular misalignment</li> </ul>

In case of angular misalignment between transducer faces, the gain step will increase as shown in the table below:

Angular misalignment	Gain step increase
2°	1
3°	2
4°	3
5°	5

### Flow velocity error conditions

Condition	Cause
$\Delta$ flow velocity values (between path 1 and path 2) > 1 (2-path systems only)	<ul style="list-style-type: none"> <li>Bad inlet conditions (the higher the delta, the worse the inlet conditions)</li> <li>Disturbances in the pipe (bad flow profile)</li> </ul>
Unstable/fluctuating values	<ul style="list-style-type: none"> <li>Air bubbles or solids in media</li> <li>Bad inlet conditions</li> </ul>

The actual velocities for the paths should be stable, constant and smoothly changing values between 0 and 10 m/s.

## Technical data

### 10.1 SONO 3500 CT

Table 10- 1 SONO 3500 CT

Description	Specification
Enclosure design/material	Fiber glass reinforced polyamide in light-gray color
Enclosure	IP67 according to EN 60529 and DIN 40050 (NEMA 4X/6)
Wall mounting kit	Terminal box made of fiber glass reinforced polyamide in light-gray color with 2 + 2 cable glands (output, supply and transducer cables) and a stainless steel bracket for wall or pipe mounting
Cable glands	In wall mounting kit: <ul style="list-style-type: none"> <li>• 4 x M20 PA plastic cable glands (2 for mains and output cable, 2 for the transducer coaxial cables)</li> </ul>
Ambient temperature	-10 °C to +55 °C (14 °F to 131 °F) <sup>1)</sup>
Storage temperature	-40 °C to + 85 °C (-40 °F to +185 °F)
Transducer/sensor cables	<ul style="list-style-type: none"> <li>• Coaxial cable, impedance 75 Ohm, Ø app. 6 mm;</li> <li>• Cable length: Max. 30 meter between transmitter and transducer (5 m (16.4 ft), 10 m (32.8 ft), 20 m (65.6 ft), or 30 m (98.4 ft) available)</li> </ul>
Mechanical vibration	2 g, 1 to 800 Hz sinusoidal in all directions according to IEC 68-2-6
Power supply	Mains with single battery backup (always store a replacement 3.6 V LiSOCl (Lithium Thionyl Chloride) battery <sup>2)</sup> ): <ul style="list-style-type: none"> <li>• 87 to 265 V AC (50 to 60 Hz)</li> </ul>
Display	<ul style="list-style-type: none"> <li>• LCD, 8 digits, additional 2 digits and symbols for status information</li> <li>• Units: Volume unit: m<sup>3</sup> (default display unit), Flow unit: m<sup>3</sup>/h (default display unit)</li> <li>• Alarm codes (F 1 to F 9) for: path 1 or 2 not measuring, internal failure, power supply failure, flow overload, pulse output frequency overload, data logger warning</li> </ul>
Push button	One push button for toggling between display information
Measuring function	<ul style="list-style-type: none"> <li>• 0.5 Hz (battery mode)</li> <li>• 15 Hz (mains-powered)</li> </ul>
Communication	<ul style="list-style-type: none"> <li>• IrDA on display panel (Modbus RTU protocol)</li> </ul>

Description	Specification
Outputs (standard)	<ul style="list-style-type: none"> <li>• Two passive, galvanically isolated open drain-mos outputs (output A and B)</li> <li>• Max. <math>\pm 35</math> V, 50 mA</li> <li>• Output A: Preset to pulse output for forward flow (default: 100 l/pulse)</li> <li>• Output B: Preset to alarm for present failure</li> <li>• Pulse with: 5, 10, 20, 50, 100, 200, 500 ms (default: 5 ms)</li> <li>• Max. pulse frequency: 100 Hz at Qmax setting (105% of Qs)</li> </ul>
EMC performance	EN/IEC 61326-1 (Industry)
Transmitter weight	1.5 kg (3 lb)

<sup>1)</sup> MID: environment class -10°C to +55°C (14°F to 131°F)

<sup>2)</sup> Waste industrial batteries are accepted back by the producer or importer, who has originally marketed the battery, or by the producer or importer, where the new industrial battery is purchased.

## 10.2 Battery

### Battery type

Replaceable 3.6 V LiSOCl (Lithium Thionyl Chloride) single battery (16 Ah)

### Note

The battery is not rechargeable; it should be replaced at least every 6 years.

### Consumption and battery operation time calculation

Every 5 minutes the advanced power management system of the transmitter calculates the battery consumption and the remaining battery operation time.

The ambient temperature of the transmitter its also influence the battery capacity.

The typical operation time up to 6 years is based on only 80% battery capacity, low pulse output frequency, seldom use of communication and an operation time/temperature profile of 5% at 0 °C (32 °F), 80% at 15 °C (59 °F) and 15% at 50 °C (122 °F).

The effect of other temperatures is shown in the figure below.

A variation in temperature from 15 °C to 55 °C (59 °F to 131 °F) reduces the capacity by 17% (in the figure from 15 Ah to 12½ Ah).

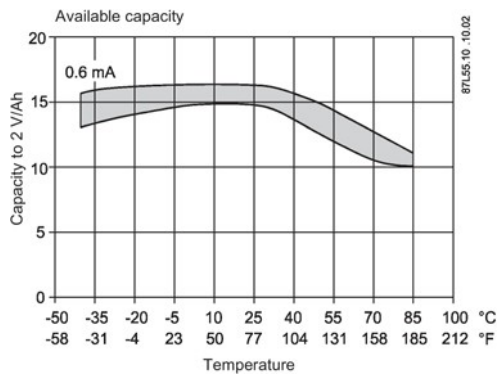

**Note**

The installation orientation of the battery may influence the battery capacity. Optimal battery capacity is achieved with the battery in an upright position.

### 10.3 Sensor for SONO 3500 CT

Table 10- 2 Technical data

Description	Specification
Pipe design	2-track sensor with flanges and integrated transducers wet-calibrated from factory
Nominal size	DN 100, 125, 150, 200, 250, 300, 350, 400, 500, 600, 700, 800, 900, 1000, 1200
Pressure rate	PN 16, PN 25, PN 40, EN 1092-1
Pipe materials	Carbon Steel EN 1.0345 / p235 GH, painted in light gray
Transducer design	Integrated version and welded onto the pipe
Transducer material	Stainless steel (AISI 316 / 1.4404) / brass (CuZn36Pb2As)
Media temperature	Remote: 2 to 200 °C (35.6 to 392 °F) <sup>1)</sup>

<sup>1)</sup> MID: minimum temperature 15 °C (59 °F)

## 10.4 Dimensional drawings for SONO 3500 CT

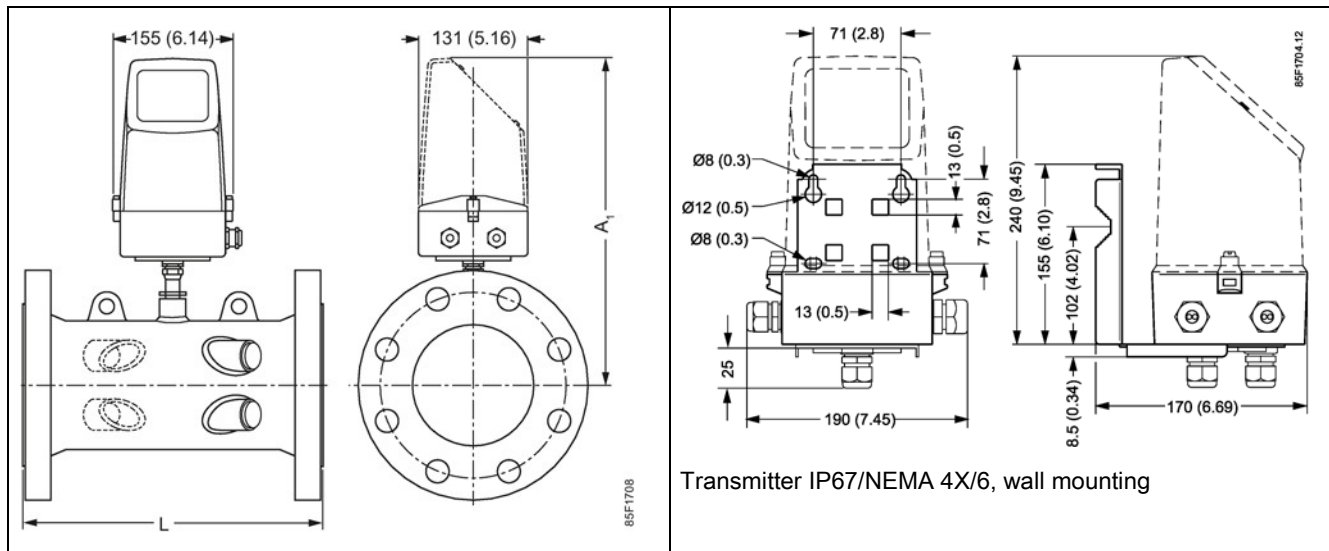

## 10.5 Pipe dimensions for SONO 3500 CT

Size	PN 16	PN 25	PN 40	Material	A1 (mm)	Lift hug			
DN	L (mm)	Weight (kg)	L (mm)	Weight (kg)	L (mm)	Weight (kg)			
100	350 +0/-2	15	-	-	350 +0/-2	18	Steel	375	No
125	350 +0/-2	18	-	-	350 +0/-3	24	Steel	380	No
150	500 +0/-3	28	-	-	500 +0/-3	34	Steel	390	No
200	500 +0/-3	38	500 +0/-3	47	500 +0/-3	55	Steel	414	No
250	600 +0/-3	60	600 +0/-3	76	600 +0/-3	91	Steel	440	No
300	500 +0/-3	66	500 +0/-3	81	-	-	Steel	466	Yes
350	550 +0/-3	94	550 +0/-3	121	-	-	Steel	495	Yes
400	600 +0/-3	124	600 +0/-3	153	-	-	Steel	507	Yes
500	625 +0/-3	194	625 +0/-3	231	-	-	Steel	558	Yes
600	750 +0/-3	303	750 +0/-3	365	-	-	Steel	609	Yes
700	875 +0/-3	361	875 +0/-3	565	-	-	Steel	660	Yes
800	1000 +0/-3	494	1000 +0/-3	770	-	-	Steel	710	Yes
900	1230 +6/-6	475	1300 +6/-6	835	-	-	Steel	810	Yes
1000	1300 +6/-6	594	1370 +6/-6	1078	-	-	Steel	910	Yes
1200	1360 +6/-6	732	-	-	-	-	Steel	1110	Yes

Size	PN 16		PN 25		PN 40		Material	A1 (inch)	Lift hug
inch	L (inch)	Weight (lb)	L (inch)	Weight (lb)	L (inch)	Weight (lb)			
4	13.78 +0/-0.08	33	-	-	13.78+0/-0.08	40	Steel	14.76	No
5	13.78 +0/-0.08	40	-	-	13.78+0/-0.08	53	Steel	14.96	No
6	19.68 +0/-0.12	62	-	-	19.68+0/-0.12	75	Steel	15.35	No
8	19.68 +0/-0.12	84	19.68 +0/-0.12	104	19.68+0/-0.12	121	Steel	16.30	No
10	23.62 +0/-0.12	132	23.62 +0/-0.12	168	23.62+0/-0.12	201	Steel	17.32	No
12	19.68 +0/-0.12	146	19.68 +0/-0.12	179	-	-	Steel	18.35	Yes
14	21.65 +0/-0.12	207	21.65 +0/-0.12	267	-	-	Steel	19.49	Yes
16	23.62 +0/-0.12	273	23.62 +0/-0.12	337	-	-	Steel	19.96	Yes
20	24.61 +0/-0.12	428	24.61 +0/-0.12	509	-	-	Steel	21.97	Yes
24	29.53 +0/-0.12	668	29.53 +0/-0.12	805	-	-	Steel	23.98	Yes
28	34.45 +0/-0.12	796	34.45 +0/-0.12	1246	-	-	Steel	25.98	Yes
32	39.37 +0/-0.12	1089	39.37 +0/-0.12	1698	-	-	Steel	27.95	Yes
36	48.43 +/-0.24	1047	51.18 +/-0.24	1841	-	-	Steel	31.89	Yes
40	51.18 +/-0.24	1310	53.94 +/-0.24	2205	-	-	Steel	35.83	Yes
48	53.54 +/-0.24	1614	-	-	-	-	Steel	43.70	Yes

Weight for transmitter/electronics 1.5 kg (3.3 lb)  
For flange values - see norm EN 1092-1  
- means not available.

## Parameter lists

The following tables show the various parameters available via SIMATIC PDM.

The parameters are accessible at three different levels:

- Read: Maintenance level
- Read/Write (R/W): Specialist level (write access is only permitted after entering the user password; default password is 1000)
- Hardware locked (HW key): The parameter is only accessible when a HW key is mounted

---

### Note

For type-approved and verified SONO 3500 CT flowmeter the settings are HW key protected and therefore read only. This HW key is protected via the verification sealing. The verification sealing can only be broken by the user with the acceptance of the local authorities.

---

## A.1 Identification

Table A- 1 Identification parameters (FW 2.03 and EDD 1.02.07-01)

Parameter	Default value	Value range	Access level	Description	
1	Application identifier	Identity		R/W	Customer application identification information (max 16 characters)
2	Application location	Location		R/W	Customer application location information (max 16 characters)
<b>Device</b>					
5	Sensor size	Product dependent		R/W	Pipe diameter of the sensor. It is only a text field for measurement system information. The value has no influence on the measurement. Please see inner diameter at pipe date in parameter 306
8	Totalizer unit	m <sup>3</sup>	See Unit conversion table (Page 83)	R/W	Totalizer unit as text for volume. Change the unit in parameter table if the device menu "Unit guide (offline)" does not list the wanted unit. <b>Note:</b> The device display can show "m <sup>3</sup> " unit only - other units cannot be shown on the display, but will be used and shown online via PDM

Parameter		Default value	Value range	Access level	Description
9	Flowrate unit	m <sup>3</sup> /h	See Human Interface (Page 83)	R/W	Flow unit as text for actual flowrate. Change the unit in parameter table if the device menu "Unit guide (offline)" does not list the wanted unit. Note: The device display can show "m <sup>3</sup> /s" unit only - other units cannot be shown on the display, but will be used and shown online via PDM.
10	Maximum flow	Qmax		R/W	Maximum flow
373	Low flow cut-off	0.25	0 ... 10	R/W	If the flow comes below this percentage of Qmax, then the flow value is set to zero
20	Vendor name	Danfoss A/S		Read	Danfoss A/S, Denmark
21	Module type	11	0 ... 14	Read	Type of flowmeter
22	Software version	2.03			Software version of the flowmeter
23	Product code number	Product dependent			Production sales code number (the first part of the system number on the nameplate)
24	System Serial number	Product dependent		R/W	Production number (the second part of the system number on the nameplate)
25	Transmitter serial number	Product dependent		HW key	Serial number of the electronics
26	Sensor serial number	Product dependent			Serial number of the sensor
373	Low flow cut-off	0.25	0 ... 10	R/W	If the flow comes below this percentage of Qmax, then the flow value is set to zero

## A.2 Output

Table A-2 Output parameters

Parameter		Default value	Value range	Access level	Description
100	Actual date and time	Product dependent		R/W	Actual date and time (day-month-year and hours:minutes:seconds)
101	Totalizer 1	0	-2000000001 ... +2000000001	Read	Volume for totalization register 1
102	Totalizer 2	0	-2000000001 ... +2000000001	Read	Volume for totalization register 2
103	Customer totalizer 3	0		Read	Customer totalizer 3 based on totalizer 1 set up
104	Reset customer totalizer 3	No	No, Yes	R/W	Reset of customer totalizer
105	Customer totalizer 3 reset date	last reset date	dd-mm-yyyy, hh:mm:ss		Date and time when customer totalizer has been reset

Parameter		Default value	Value range	Access level	Description
106	Flow rate			Read	Actual flow value
107	Relative flow rate	0		Read	Actual flow value in relation to Qmax
108	Actual velocity for path 1	0		Read	The actual flow velocity for path 1 in m/s (SI-unit)
109	Actual velocity for path 2	0			The actual flow velocity for path 2 in m/s (SI-unit). Valid for 2-path solutions only
110	Path 1 gain step	15	1 to 15	Read	Amplifier setting when measuring path 1
111	Path 2 gain step	15	1 to 15	Read	Amplifier setting when measuring path 2. Valid for 2-path solutions only
<b>Pulse A B</b>					
430	Output A enable	Yes	No, Yes	R/W	Select "Yes" to enable output A
431	Pulse A function	Forward	Forward, Reverse, Forward net, Reverse net	R/W	Pulse output calculation on pure forward flow or pure reverse flow - or net flow for forward and reverse pulse flow. Valid if pulse output A is enabled
432	Amount per pulse A	1.000000 (m <sup>3</sup> )	0.000001 ... 1000000000	R/W	Volume per pulse and selected unit Valid if pulse output A is enabled.
433	Pulse width for pulse A	5 ms	5, 10, 20, 50, 100, 200, 500 ms	R/W	Pulse length when the pulse is active. Valid if pulse output A is enabled
440	Output B enable	Yes	No, Yes	R/W	Select "Yes" to enable output B
441	Pulse B function	Alarm	Pulse, Alarm, Call up	R/W	Configuration of output B as pulse - alarm or call up function. Valid if pulse output B is enabled
442	Pulse B direction	Reverse	Forward, Reverse, Forward net, Reverse net.	R/W	Pulse output calculation on pure forward flow or pure reverse flow - or net flow for forward and reverse pulse flow. Valid if pulse output B is enabled and pulse function selected
443	Amount per pulse B	1.000000 (m <sup>3</sup> )	0.000001 ... 1000000000	R/W	Volume per pulse. Valid if pulse output B is enabled and pulse function selected
444	Pulse width for pulse B	5 ms	5, 10, 20, 50, 100, 200, 500 ms	R/W	Pulse length when the pulse is active. Valid if pulse output B is enabled and pulse function selected
<b>Communication</b>					
For editing the communication settings, use PDM device menu "Communication Setting"					
591	Device Communication Address	1	1 ... 247	Read	Meter has default address value 1 with selectable address up to 247
592	Baudrate	4	0 ... 5	Read	Communication port speed
593	Parity	0	0 ... 3	Read	Communication port parity
594	Interframe space	35	35 ... 255	Read	Minimum space between two messages (bytes x 10)
595	Response delay	5	1 ... 50	Read	Minimum time from receiving a request to its response

Parameter	Default value	Value range	Access level	Description	
<b>Data logger</b>					
600	Log interval	Monthly	Daily, Weekly, Monthly	R/W	Log interval
601	Day of week, if weekly log	Sunday	Monday to Sunday	R/W	When log interval is set to weekly logging, this parameter defines what weekday the logging is performed. Valid if weekly log interval is activated
602	Limit for too high consumption	1E+09	-3.4E+38 ... +3.4E+38	R/W	Limit for too low consumption during current log interval. Based on totalizer 1 and the selected unit
603	Limit for too low consumption	No	-3.4E+38 ... +3.4E+38	R/W	Limit for too low consumption during current log interval. Based on totalizer 1 and the selected unit
604	Reset log		No, Yes	HW key	Reset data logger
<b>Periodic log Totalizer 1</b>					
160	Next settling date	01-01-2000	dd-mm-yyyy	R/W	Next settling date where actual value of totalizer 1 is stored
161	Latest settling date	01-01-2000	dd-mm-yyyy	Read	Latest settling date where value of totalizer 1 was stored
162	Latest totalizer 1 value	0		Read	Latest stored value of totalizer 1
163	Previous settling date	01-01-2000		Read	Previous settling date where value of totalizer 1 was stored
164	Previous totalizer 1 value	0	dd-mm-yyyy	Read	Previously stored value of totalizer 1

## A.3 Diagnostic

Table A-3 Diagnostic

Parameter	Default value	Value range	Access level	Description	
<b>Diagnostic</b>					
500	Latest service date	01-01-2000	dd-mm-yyyy	R/W	Latest service date (can also be used for date of installation)
501	Operating hours since power up	0	3.4E+38 h	Read	Total operation hours since last power up
503	Numbers of power up	0	0 ... 65535	Read	Total number of power-ups since first power-up.

Parameter	Default value	Value range	Access level	Description	
<b>Alarm</b>					
200	Fault status		One or more of the following values: 1, 2, 3, 4, ... up to 16	Read	Fault status 1: Path 1 error 2: Path 2 error 3: Dual slope calibration error 4: Database checksum error 5: Low power warning 6: Flow overload warning 7: Pulse A overload warning 8: Pulse B overload warning 9: Consumption interval error 10: Not used 11: Not used 12: Not used 13: Not used 14: Not used 15: Not used 16: Not used
202	Date of fault log reset	Last reset date	dd-mm-yyyy, hh:mm:ss	Read	Date of last fault log reset
204	Reset the fault log and faults	No	No, Yes	R/W	Reset the fault log and faults
205	Call up acknowledge	No	No, Yes	R/W	Select "Yes" to reset active call-up
209	Reset consumption log fault	No	No, Yes	R/W	Reset the consumption fault. Caused by too low or too high consumption in the log interval
210	Path 1 alarm output enable	Yes	No, Yes	R/W	Select "Yes" to enable current alarm on alarm output / call-up
211	Path 1 fault hours	e.g. 36 h	Read;		Total hours fault active
212	Path 1 fault counter	e.g. 4	0 ... 65535	Read	Total number of faults. Valid only if alarm is enabled
213	Path 1 fault appears	Last fault appear date	dd-mm-yyyy, hh:mm:ss	Read	Last time the fault appeared. Valid only if alarm is enabled
214	Path 1 fault disappears	Last fault disappear date	dd-mm-yyyy, hh:mm:ss	Read	Last time the fault disappeared. Valid only if alarm is enabled
215	Path 2 alarm output enable	Yes	No, Yes	R/W	Select "Yes" to enable active alarm on alarm output / call-up. Valid only for 2-path solutions
216	Path 2 fault hours	e.g. 36 h	Read;	Read	Total hours fault active. Valid only for 2-path solutions and if alarm is enabled

Parameter		Default value	Value range	Access level	Description
217	Path 2 fault counter	e.g. 4	0 ... 65535	Read	Total number of faults. Valid only for 2-path solutions and if alarm is enabled
218	Path 2 fault appears	Last fault appear date	dd-mm-yyyy, hh:mm:ss	Read	First time the fault appeared. Valid only for 2-path solutions and if alarm is enabled
219	Path 2 fault disappears	Last fault disappear date	dd-mm-yyyy, hh:mm:ss	Read	Last time the fault disappeared. Valid only for 2-path solutions and if alarm is enabled
220	Dual slope alarm output enable	Yes	No, Yes	R/W	Select "Yes" to enable active alarm on alarm output / call-up
221	Dual slope fault hours	e.g. 0 h	0 ... 65535	Read	Total hours fault active. Valid only if alarm is enabled
222	Dual slope fault counter	e.g. 0	0 ... 65535	Read	Total number of faults. Valid only if alarm is enabled
223	Dual slope fault appears	e.g. 0 h	0 ... 65535	Read	First time the fault appeared. Valid only if alarm is enabled
224	Dual slope fault disappears	e.g. 0	0 ... 65535	Read	Last time the fault disappeared. Valid only if alarm is enabled
225	Parameter checksum alarm output enable	Yes	No, Yes	R/W	Select "Yes" to enable active alarm on alarm output / call-up
226	Parameter checksum fault hours	e.g. 0 h	0 ... 65535	Read	Total hours fault active. Valid only if alarm is enabled
227	Parameter checksum fault counter	e.g. 0	0 ... 65535	Read	Total number of faults. Valid only if alarm is enabled
228	Parameter checksum fault appears	e.g. 0 h	0 ... 65535	Read	First time the fault appeared. Valid only if alarm is enabled
229	Parameter checksum fault disappears	e.g. 0	0 ... 65535	Read	Password to change parameters in the flowmeter. Valid only if alarm is enabled
230	Low power alarm output enable	Yes	No, Yes	R/W	Select "Yes" to enable active alarm on alarm output / call-up
231	Low power fault hours	e.g. 0 h	0 ... 65535	Read	Total hours fault active. Valid only if alarm is enabled
232	Low power fault counter	e.g. 0	0 ... 65535	Read	Total number of faults. Valid only if alarm is enabled
233	Low power fault appears	e.g. 0 h	0 ... 65535	Read	First time the fault appeared. Valid only if alarm is enabled
234	Low power fault disappears	e.g. 0	0 ... 65535	Read	Last time the fault disappeared. Valid only if alarm is enabled
235	Flow overflow alarm output enable	Yes	No, Yes	R/W	Select "Yes" to enable active alarm on alarm output / call-up
236	Overflow fault hours	e.g. 0 h	0 ... 65535	Read	Total hours fault active. Valid only if alarm is enabled

Parameter		Default value	Value range	Access level	Description
237	Overflow fault counter	e.g. 0	0 ... 65535	Read	Total number of faults. Valid only if alarm is enabled
238	Overflow fault appears	e.g. 0 h	0 ... 65535	Read	First time the fault appeared. Valid only if alarm is enabled
239	Overflow fault disappears	e.g. 0	0 ... 65535	Read	Last time the fault disappeared. Valid only if alarm is enabled
240	Pulse A overload alarm output enable	Yes	No, Yes	R/W	Select "Yes" to enable active alarm on alarm output / call-up
241	Pulse A overload fault hours	e.g. 0 h	0 ... 65535	Read	Total hours fault active. Valid only if alarm is enabled
242	Pulse A overload fault counter	e.g. 0	0 ... 65535	Read	Total number of faults. Valid only if alarm is enabled
243	Pulse A overload fault appears	e.g. 0 h	0 ... 65535	Read	First time the fault appeared. Valid only if alarm is enabled
244	Pulse A overload fault disappears	e.g. 0	0 ... 65535	Read	Last time the fault disappeared. Valid only if alarm is enabled
245	Pulse B overload alarm output enable	Yes	No, Yes	R/W	Select "Yes" to enable active alarm on alarm output / call-up
246	Pulse B overload fault hours	e.g. 0 h	0 ... 65535	Read	Total hours fault active. Valid only if alarm is enabled
247	Pulse B overload fault counter	e.g. 0	0 ... 65535	Read	Total number of faults. Valid only if alarm is enabled
248	Pulse B overload fault appears	e.g. 0 h	0 ... 65535	Read	First time the fault appeared. Valid only if alarm is enabled
249	Pulse B overload fault disappears	e.g. 0	0 ... 65535	Read	Last time the fault disappeared. Valid only if alarm is enabled
250	Consumption alarm output enable	Yes	No, Yes	R/W	Select "Yes" to enable active alarm on alarm output / call-up
251	Consumption fault hours	e.g. 0 h	0 ... 65535	Read	Total hours fault active. Valid only if alarm is enabled
252	Consumption fault counter	e.g. 0	0 ... 65535	Read	Total number of faults. Valid only if alarm is enabled
253	Consumption fault appears	e.g. 0 h	0 ... 65535	Read	First time the fault appeared. Valid only if alarm is enabled
254	Consumption fault disappears	e.g. 0	0 ... 65535	Read	Last time the fault disappeared. Valid only if alarm is enabled
255	Leakage alarm output enable	Yes	No, Yes	R/W	Select "Yes" to enable active alarm on alarm output / call-up
256	Leakage fault hours	e.g. 0 h	0 ... 65535	Read	Total hours fault active. Valid only if alarm is enabled
257	Leakage fault counter	e.g. 0	0 ... 65535	Read	Total number of faults. Valid only if alarm is enabled

Parameter		Default value	Value range	Access level	Description
258	Leakage fault appears	e.g. 0 h	0 ... 65535	Read	First time the fault appeared. Valid only if alarm is enabled
259	Leakage fault disappears	e.g. 0	0 ... 65535	Read	Last time the fault disappeared. Valid only if alarm is enabled
260	Empty pipe alarm output enable	Yes	No, Yes	R/W	Select "Yes" to enable active alarm on alarm output / call-up
261	Empty pipe fault timer	e.g. 0 h	0 ... 65535	Read	Total hours fault active. Valid only if alarm is enabled
262	Empty pipe fault counter	e.g. 0	0 ... 65535	Read	Total number of faults. Valid only if alarm is enabled
263	Empty pipe fault appears	e.g. 0 h	0 ... 65535	Read	First time the fault appeared. Valid only if alarm is enabled
264	Empty pipe fault disappears	e.g. 0	0 ... 65535	Read	Last time the fault disappeared. Valid only if alarm is enabled
<b>Service</b>					
510	Fixed flow mode enable	Yes	No, Yes	R/W	Select "Yes" to force the device to show a fixed flow value  Default must be "No" Always manually reset the value to "No"
511	Fixed flow value	0	-1E+09 ... 1E+09	R/W	Fixed flow value for enabled fixed flow
515	Controlling output A and B	Auto	Auto, Forced	HW key	Control of output A and B is used to stop or force the output A and/or B.  For editing, use device menu "Service". Valid if pulse output is enabled
<b>Power</b>					
130	Consumed battery capacity	e.g. 2.054239 Ah		Read	The amount of energy consumed since last time the battery was replaced. Valid only for battery-powered versions
501	Operating hours since power up	1105 h	3.4 E+38	Read	Total operation hours since first power up
503	Numbers of power up	e.g. 4	0 ... 65535	Read	Total number of power-ups since first power-up.
540	Battery change enable	No	No, Yes	R/W	Select "Yes" to set battery installation date to current date and reset remaining battery operation capacity to maximum. Valid only for battery-powered versions
541	Battery installation date	last battery installation date	dd-mm-yyyy; hh:mm:ss	Read	Latest installation date of batteries. Valid only for battery-powered versions
542	Power supply mode	Battery only	Battery only, Mains only, Mains with backup battery.	Read	The flowmeter is either powered by battery only, mains only or by mains with battery backup.  The type is defined by the order code and cannot be changed.

Parameter		Default value	Value range	Access level	Description
543	Actual battery capacity	25.000000	0 ... 50	R/W**	The capacity of the battery in Ah - Single 12.5 Ah - Dual battery pack 25.0 Ah Valid only for battery-powered versions
544	Battery alarm limit	80	0 ... 90	R/W	Present an alarm when the consumed energy exceeds this percentage of the battery capacity. Valid only for battery-powered versions

\*\* Maintenance = Read only

## A.4 Meter setup

Table A- 4 Meter setup parameters

Parameter		Default value	Value range	Access level	Description
<b>Meter Setup</b>					
307	Flow velocity offset	0 m/s	-10 ... 10 m/s	HW key	Velocity added to measured flow velocity
310	Calibration factor	1.0	0 ... 2	R/W	This calibration factor will be calculated at the factory with wet-calibration.
311	Adjustment Factor	1	- 2 ... 2	R/W	Meter correction factor for customer adjustment of the calculated flow value. Can be used at installations where a reference meter is used to get reference to the true flow rate
312	Transducer cable length	Product dependent	0 ... 200 m	R/W	Cable length (m) from sensor to transmitter
372	Filter time constant	Product dependent	0 ... 100 s	R/W	General time filter for flow measurement. Filter constant is the time that must pass before the filter's output value is at 70% of the change of its input value. Higher number gives a slower and more stable flow signal.
380	Protect linearization from user access.	No	No, Yes	Read	Protection of the linearization parameters. It is decided by the order number and cannot be changed. The linearization parameters are listed in the device menu "Linearization"

Parameter		Default value	Value range	Access level	Description
<b>Totalizer</b>					
400	Flow direction totalizer 1	Forward	Forward, Reverse, Net	R/W	Calculation principle on flow direction for forward, reverse or net flow
401	Totalizer 1 change date	Last change date	dd-mm-yyyy; hh:mm:ss	Read	Date and time when totalizer 1 function was changed
410	Flow direction totalizer 2	Reverse	Forward, Reverse, Net	R/W	Calculation principle on flow direction for forward - reverse or net flow
411	Totalizer 2 change date	Last change date	dd-mm-yyyy; hh:mm:ss	Read	Date and time when totalizer 2 function was changed
<b>Pipe data</b>					
300	Number of paths	Product dependent	2	R/W	Number of paths on the sensor
302	Max sample frequency	15	15	Read	The maximum frequency for flow measurement
303	Sample frequency	0.5	15	HW key	The frequency at which the flow is measured
304	Rn for path 1	Product dependent	3.4E+38 m	Read	R-factor for path 1.
305	Rn for path 2	Product dependent	3.4E+38 m	Read	R-factor for path 2.
306	Inner pipe diameter	Product dependent	0.05 ... 1.200 m	Read	Inner pipe diameter in meters.

## A.5 Human Interface

Table A- 5 Human Interface parameters

Parameter		Default value	Value range	Access level	Description
420	Decimal point	Automatic point adjust	No point; One digit after point; Two digits after point; Three digits after point; Automatic point adjust.	R/W	Decimal numbers for displayed totalized value
422	Operator Menu 1	All	1 to 5	Read only	Menu setup 1. Totalizer 1 2. Totalizer 2 3. Actual flow rate 4. Error menu 5. Display test menu For editing, use device menu "Human Interface"

## A.6 Unit conversion table

The following tables show examples of totalizer and flow rate units. More are available via SIMATIC PDM tool

Table A- 6 Totalizer units

Unit	Correction factor
Default	1 m <sup>3</sup>
m <sup>3</sup> *100	0.01
Gallon (US)	264.1721
G*100 (100*Gallon)	2.641721
G*1000 (1000*Gallon)	0.2641721
MG (1000000*Gallon)	0.0002641721
AI (Acre Inches)	0.009728558
AF (Acre ft)	0.0008107132
CF*100 (100*ft <sup>3</sup> )	0.3531467
CF*1000 (1000*ft <sup>3</sup> )	0.03531467
l*100 (liter)	10
kl (1000*liter)	1
MI (Mega liter)	0.001

Table A- 7 Flow rate units

Flow rate	Correction factor parameter
Default	1 m <sup>3</sup> /s
m <sup>3</sup> /min (m <sup>3</sup> /minute)	60
m <sup>3</sup> /h (m <sup>3</sup> /hour)	3600
m <sup>3</sup> /d (m <sup>3</sup> /day)	86400
GPS (Gallon/second)	264.1721
GPM (Gallon/minute)	15850.32
GPH (Gallon/hour)	951019.4
GPD (Gallon/day)	22824465
MGPD (1000000*Gallon/day)	22.824465
CFS (ft <sup>3</sup> /second)	35.31467
CFM (ft <sup>3</sup> /minute)	2118.882
CFH (ft <sup>3</sup> /hour)	127132.8
l/s (liter/second)	1000
l/min (liter/minute)	60000
l/h (liter/hour)	3600000
MI/d (1000000Liter/day)	86.4

# Settings

# B

## B.1 Factory settings

The transmitter is from factory configured according to the order specification.

For the calibration / configuration of the flowmeter the application specific pipe dimensions and the specific transducer locations can require an update.

---

### Note

For type-approved and verified SONO 3500 CT flowmeter the settings are HW key protected and therefore read only. This HW key is protected via the verification sealing. The verification sealing can only be broken by the user with the acceptance of the local authorities.

---

Table B- 1 Factory settings

Identification	2-path factory settings (DN 50 to DN 1200)	Possible settings
Meter identification	-	Free text 15 characters
Application location	-	Free text 15 characters
Display menu	Menu 1 – 5 (all)	Menu 1 – 5, min one of the five
<b>Pipe data</b>		
Number of paths	2	1 or 2
Inner pipe diameter (m)	for SONO 3500 CT factory pre-configured according the order code	may not be changed
Q max	Qmax is 105% of Qs (Qs is shown on the system nameplate). For SONO 3500 CT factory pre-configured according the selection via the order code.	Adjustable
Low flow cut-off (% of Qmax)	0.25 % For SONO 3500 CT factory pre-configured. It is %-value related to the Qmax setting. The %-value is equal to 50% of Qi (Qi is shown on the system nameplate).	Adjustable between 0 ... 10%
Filter time constant	Factory pre-configured to typical 5 s (for larger pipe size higher values are used)	Adjustable between 5 ... 1000 s
Geometry factor path 1	For SONO 3500 CT factory pre-configured according the order code	Auto set from pipe geometry help program in PDM
Geometry factor path 2	For SONO 3500 CT factory pre-configured according the order code	Auto set from pipe geometry help program in PDM
<b>Correction factor</b>		
Costumer correction factor	1	0.5 ... 1.5

<b>Measuring unit and factors</b>		
Flow unit factor	3600 (for flow unit m <sup>3</sup> /h)	Auto set from unit guide
Totalizer volume unit factor	1	Auto set from unit guide
Flow unit text	m <sup>3</sup> /h	Auto set from unit guide, but only m <sup>3</sup> /h can be shown on display
Totalizer unit text	m <sup>3</sup>	Auto set from unit guide, but only m <sup>3</sup> can be shown on display
<b>Totalizer directions</b>		
Totalizer 1 direction	Forward	Forward/Reverse/Forward net/Reverse net
Totalizer 2 direction	Reverse	Forward/Reverse/Forward net/Reverse net
<b>Digital output 1</b>		
Active	On	On/off
Direction	Forward	Forward/Reverse/Forward net/Reverse net
Amount per pulse	0.1 m <sup>3</sup>	Unit: The same as Totalizer unit Value freely selectable
Pulse width	5 ms	5, 10, 20, 50, 100, 200, 500 ms
<b>Digital Output 2</b>		
Active	On	On/off
Function	Alarm	Pulse/Alarm/Call up
Direction	No influence, while "Alarm"	Forward/Reverse/Forward net/Reverse net
Amount per pulse	No influence, while "Alarm"	Unit: The same as Totalizer unit Value freely selectable
Pulse width	No influence, while "Alarm"	5, 10, 20, 50, 100, 200, 500 ms

## B.2 Factory settings for Modbus communication

<b>Parameter</b>	<b>Default setting</b>
Slave device address	1
Data transmission rate	19 200 baud
Parity	Even
Stop bit	1
Response timeout	10000 ms
Response delay	5 ms
Interframe space	35 bits

The settings can be changed by way of SIMATIC PDM or through the Modbus communication. To support the option with current output module the s in the preceding table are recommended.



For more information

[www.danfoss.com](http://www.danfoss.com)

**Danfoss A/S**

Heating Segment • [heating.danfoss.com](http://heating.danfoss.com) • +45 7488 2222 • E-Mail: [heating@danfoss.com](mailto:heating@danfoss.com)

---

Danfoss can accept no responsibility for possible errors in catalogues, brochures and other printed material. Danfoss reserves the right to alter its products without notice. This also applies to products already on order provided that such alterations can be made without subsequential changes being necessary in specifications already agreed.

---