

Data Sheet

# Shut-off valve SVA-140B Strainer FIA-140B

## 140 bar (2030 psi) series

The new 140 bar manual valve range for Industrial CO<sub>2</sub> Trans-critical Systems



The new 140 bar manual valve range for Industrial CO<sub>2</sub> Trans-critical Systems is based on the successful modular Standard SVL platform. The same flexibility, simplicity and efficiency are features offered in this new series.

The valves are available as complete valves

- From DN 50 (2") to 100 (4")
- In angle or straightway
- With DIN or ANSI butt-weld connections and DIN or ASME hard soldering (brazing) connections up to 64mm or 2 1/8"
- 2 different configurations:
  - Shut-off (SVA-140B)
  - Strainer (FIA-140B)

# ЮГОВ - Проект

інженерно-виробниче підприємство

Офіційний дистриб'ютор  
Danfoss в Україні



[ugov.ua](http://ugov.ua)

## Features

### **SVA-140B**

- Applicable to: R744 (CO<sub>2</sub>) Sub and Trans critical
- Modular Concept:
  - Each valve housing is available with several different connection types and sizes
  - Possible to convert FIA-140B strainers to other products in the Flexline™ SVL family (e.g. shut-off valve) just by replacing the complete top part
- Max. working pressure: 140 bar (2030 psi)
- Max. differential pressure: 110 bar (1595 psi)
- Temperature range: -40 °C to +150 °C (-40 °F to + 302 °F)
- Fast and easy valve overhaul service. It is easy to replace the top part and no welding is needed
- Available in angle and straightway versions
- Each valve type is clearly marked with type, size and performance range
- The valves and caps are prepared for sealing, to prevent operation by unauthorized persons, using a seal wire
- Balanced piston design providing smooth low torque opening of valve at high differential pressure
- Internal metal back seating
- Can accept flow in both directions
- Housing and bonnet material is low temperature steel according to requirements of the Pressure Equipment Directive and other international classification authorities
- Equipped with bolts in low temp steel with high tensile strength
- Classification: UL, CRN etc. To get an updated list of certifications on the products please contact your local Danfoss Sales Company

### **FIA-140B**

- Applicable: R744 (CO<sub>2</sub>) Sub and Trans critical
  - Each valve housing is available with several different connection types and sizes
  - Possible to convert SVA-140B strainers to other products in the Flexline™ SVL family (e.g. strainer) just by replacing the complete top part
- Max. working pressure: 140 bar (2030 psi)
- Temperature range -40 °C to +150 °C (-40 °F to +302 °F)
- Available in angle and straightway versions
- Each valve type is clearly marked with type, size and performance range
- Filter net of stainless steel mounted direct without extra gaskets means easy servicing
- Two types of strainer inserts are available:
  - A plain insert of stainless steel
  - A pleated insert with extra large surface, which ensures long intervals between cleaning and low pressure drop
- FIA-140B 50-100 (2 - 4 in.): A large capacity filter bag can be inserted for cleaning plant during commissioning
- FIA-140B 80-100 (3 - 4 in.) can be equipped with a magnetic insert for detention of iron particles and other magnetic particles
- Housing and bonnet material is low temperature steel according to requirements of the Pressure Equipment Directive and other international classification authorities
- Equipped with bolts in low temp steel with high tensile strength
- Classification: UL, CRN etc. To get an updated list of certifications on the products please contact your local Danfoss Sales Company

## Media

### **Refrigerants**

Applicable to R744 (CO<sub>2</sub>).

### **New refrigerants**

Danfoss products are continually evaluated for use with new refrigerants depending on market requirements.

When a refrigerant is approved for use by Danfoss, it is added to the relevant portfolio, and the R number of the refrigerant (e.g. R513A) will be added to the technical data of the code number. Therefore, products for specific refrigerants are best checked at [store.danfoss.com/en/](https://store.danfoss.com/en/), or by contacting your local Danfoss representative.

## Product specification

### Pressure and temperature data

Table 1: Temperature and pressure

Description	Values
Temperature range	-40 °C /+150 °C (-40 °F /+302 °F)
Max. working pressure	140 bar (2030 psi)
Max. differential pressure <sup>(*)</sup>	110 bar (1595 psi)

<sup>(\*)</sup> Only valid for SVA-140B

### Design

#### Housing

Made of special, cold resistant steel

#### Valve cone (SVA-140B)

A PEEK tightening ring provides perfect sealing with minimum closing force in the entire temperature range.

#### Spindle

Made of polished stainless steel.

#### Piston

An orifice through the cone and spindle equalizes the valve inlet pressure P1 with the pressure in the chamber above the piston when the spindle is operated. In this way, the valve can be operated smoothly by hand and an appropriately sized wrench.

#### Packing gland

The low temperature packing gland ensures a perfect tightness in the range: -40 °C/+150 °C (-40 °F/+302 °F). The packing gland can be re-tightened with a wrench postponing the overhaul of the valve.

### Installation

It is recommended that the valves be installed in the direction of flow indicated by the arrow on the valve body. The SVA-140B can be installed in the opposite direction, but this slightly reduces the  $k_v$ -value ( $C_v$ -value).

The valve is designed to withstand high internal pressure. However, the piping system in general should be designed to avoid liquid traps and reduce the risk of hydraulic pressure caused by thermal expansion.

For further information refer to installation instructions for SVA-140B.

Figure 1: Example of Marking Ring SVA-140B

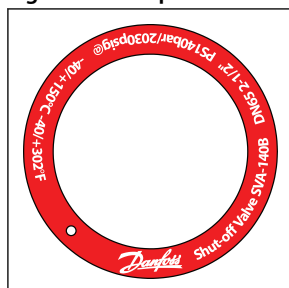
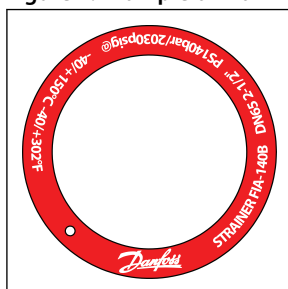

Figure 2: Example of Marking Ring FIA-140B



### Selection of strainer size

The mesh aperture size of the strainer must satisfy the requirements stated by the suppliers of the equipment to be protected.

The following recommendations of aperture size apply in general to refrigeration installations:

Table 2: All lines

First start up: (Use strainer element with removable insert for FIA DN15-40 or separate filter bag for FIA DN 50-200. 50µ insert should normally be removed after the first 24 hours of operation)	50µ
---	-----

Table 3: Liquid Lines

Ahead of pumps:	500µ [38 mesh]
After pumps:	150µ [100 mesh] / 250µ [72 mesh]

Table 4: Protection of automatic regulation equipment

Generally	150µ [100 mesh] / 250µ [72 mesh]
Sensitive equipment, e.g. suction regulators with low temperature	250µ [72 mesh]

Table 5: Suction Lines

Ahead of screw compressor	250µ [72 mesh]
Ahead of piston compressor	150µ [100 mesh]

**i NOTE:**

Mesh is the number of threads per inch. µ (microns) is the distance between two threads (1µ = 1 /1000 mm).

Table 6: Flow coefficient (DIN/ANSI)

Connection size (DN)	µ	Mesh	Wire	Wire	Free space	Screen area			
						Plain elements		Pleated elements	
FIA			mm	in.	%	cm <sup>2</sup>	in <sup>2</sup>	cm <sup>2</sup>	in <sup>2</sup>
50 (2")	150	100	0.10	0.004	36	87	13.5	200	31.2
	250	72	0.10	0.004	51	87	13.5	200	31.2
	500		0.16	0.006	57.6	87	13.5	200	31.2
65 (2½")	150	100	0.10	0.004	36	127	19.7	305	47.6
	250	72	0.10	0.004	51	127	19.7	305	47.6
	500		0.16	0.006	57.6	127	19.7	305	47.6
80 (3")	150	100	0.10	0.004	36	205	31.8	450	70.2
	250	72	0.10	0.004	51	205	31.8	450	70.2
	500	38	0.16	0.006	57.6	205	31.8	450	70.2
100 (4")	150	100	0.10	0.004	36	370	57.4	790	123.2
	250	72	0.10	0.004	51	370	57.4	790	123.2
	500	38	0.16	0.006	57.6	370	57.4	790	123.2

## Shut-off valve SVA-140B and Strainer FIA-140B 140 bar (2030 psi) series

**Table 7:  $k_v$  values for FIA angle - plain filter net/pleated filter net**

DN	FIA angle - plain filter net			FIA angle - pleated filter net		
	$\mu 150$	$\mu 250$	$\mu 500$	$\mu 150$	$\mu 250$	$\mu 500$
50	45.9	47.6	50.2	56.7	58.8	62.0
65	56.1	57.8	60.4	69.3	71.4	74.6
80	104.6	108.0	113.1	129.2	133.4	139.7
100	162.4	167.5	176.0	200.6	206.9	217.4

**Table 8:  $k_v$  values for FIA straight - plain filter net/pleated filter net**

DN	FIA straight - plain filter net			FIA straight - pleated filter net		
	$\mu 150$	$\mu 250$	$\mu 500$	$\mu 150$	$\mu 250$	$\mu 500$
50	35.1	36.4	38.4	45.9	47.6	50.2
65	42.9	44.2	46.2	56.1	57.8	60.4
80	80.0	82.6	86.5	104.6	108.0	113.1
100	124.2	128.1	134.6	162.4	167.5	176.0

## Connections

### Available with the following connections:

- Butt-weld DIN (EN 10216-2)
- Butt-weld ANSI (B 36.10 Schedule 80)
- Brazing EN 1254-5, 54 and 64mm
- Brazing ASME B16.50, 2 1/8" and 2 5/8"

The DN 50 Straight valve is machined from a normal DN 65 Straight sized valve house, but with DN 50 connections. The different geometry explains why the  $K_v/C_v$  value of the DN 50 Straight exceptionally is higher than DN 50 Angular.

**Figure 3: DIN**

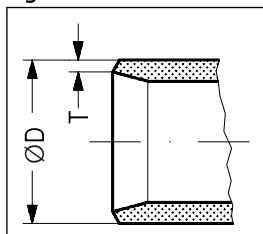

**Table 9: Butt-weld DIN (EN 10216-2)**

Size		$\varnothing D$	T	$\varnothing D$	T	$k_v$ -angle	$k_v$ -straight	$C_v$ -angle	$C_v$ -straight
mm	in.	mm	mm	in.	in.	m <sup>3</sup> /h	m <sup>3</sup> /h	US gal/min	US gal/min
50	2	60.3	5.0	2.37	0.20	67	79	77	91
65	2½	76.1	6.3	3	0.25	103	91	119	105
80	3	88.9	7.1	3.50	0.28	174	146	201	169
100	4	114.3	8.8	4.50	0.35	292	251	338	290

**Figure 4: ANSI**

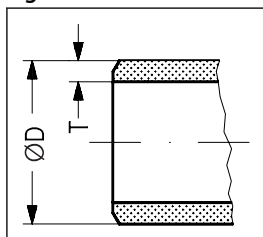

## Shut-off valve SVA-140B and Strainer FIA-140B 140 bar (2030 psi) series

**Table 10: Butt-weld ANSI (B 36.10 Schedule 80)**

Size		ØD	T	ØD	T	k <sub>v-angle</sub>	k <sub>v-straight</sub>	C <sub>v-angle</sub>	C <sub>v-straight</sub>
mm	in.	mm	mm	in.	in.	m <sup>3</sup> /h	m <sup>3</sup> /h	US <sub>gal/min</sub>	US <sub>gal/min</sub>
50	2	60.3	5.6	2.37	0.22	67	79	77	91
65	2½	73.0	7.0	2.87	0.28	103	91	119	105
80	3	88.9	7.6	3.50	0.30	174	146	201	169
100	4	114.3	8.6	4.50	0.34	292	251	338	290

**Figure 5: SD (DIN)**

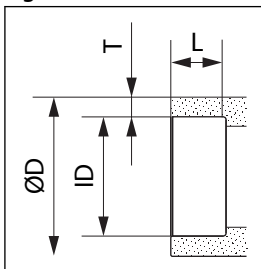

**Table 11: Brazing EN 1254-5**

Size		ØD	T	ØD	T	k <sub>v-angle</sub>	k <sub>v-straight</sub>	C <sub>v-angle</sub>	C <sub>v-straight</sub>
mm	in.	mm	mm	in.	in.	m <sup>3</sup> /h	m <sup>3</sup> /h	US <sub>gal/min</sub>	US <sub>gal/min</sub>
54		60.3	3.2	2.37	0.13	67	79	77	91
64		73.0	4.5	2.87	0.18	103	91	119	105

**Figure 6: SA (ASME)**

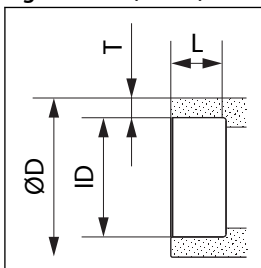

**Table 12: Brazing ASME B16.50**

Size		ØD	T	ØD	T	k <sub>v-angle</sub>	k <sub>v-straight</sub>	C <sub>v-angle</sub>	C <sub>v-straight</sub>
mm	in.	mm	mm	in.	in.	m <sup>3</sup> /h	m <sup>3</sup> /h	US <sub>gal/min</sub>	US <sub>gal/min</sub>
	2 1/8	60.3	3.2	2.37	0.13	67	79	77	91
	2 5/8	76.1	4.7	3	0.19	103	91	119	105

## Material specification

### SVA-140B 50-65 (2 – 2½ in.)

Figure 7: SVA-140B 50-65 (2 – 2½ in.)

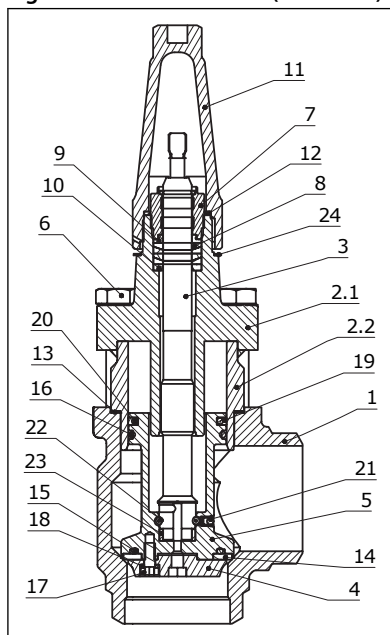

Table 13: Material and part list for DN 50-65

No.	Part	Material	EN	ISO	ASTM	GB/T
1	Housing	Steel	P285QH, 10222-4		LF2, A350	
2	Welded bonnet	Steel				
2.1	Bonnet	Steel	P285QH, 10222-4			
2.2	Distance ring	Steel	S355J2+N, 10025-2			Q355ND, 1591
3	Spindle	Stainless steel	X8CrNiS18-9, 10088-3		AISI 303	
4	Cone	Steel	11SMn30, 10087			
5	Piston	Steel	11SMn30, 10087			
6	Bolts	Steel	42CrMo4+QT, 10250-3		AISI 303	
7	Thread connection	Stainless steel	X8CrNiS18-9, 10088-3			
8	Teflon ring	PTFE				
9	External bushing	Steel				
10	Washer	Steel				
11	Cap	Aluminium				
12	Cap sealing	Nylon				
13	Gasket for top module	Grafilit-EM				
14	Cone sealing	PEEK				
15	O-ring cone sealing	EPDM				
16	O-ring Piston sealing	EPDM				
17	Cone screw	Steel				
18	Nord-Lock disc	Steel				
19	Glyd ring for main radial sealing	PTFE				
20	O-ring for main radial sealing	EPDM				
21	Expander	Steel				
22	Ball	Steel				
23	Bushing	Steel				
24	Identification wring	Aluminium				

SVA-140B 80-100 (3 – 4 in.)

Figure 8: SVA-140B 80-100 (3 – 4 in.)

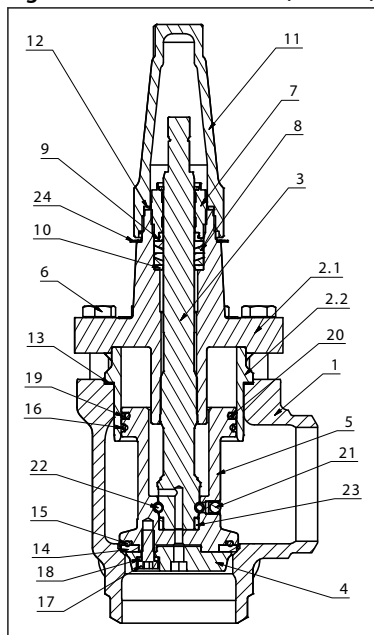

Table 14: Material and part list for DN 80-100

No.	Part	Material	EN	ISO	ASTM	GB/T
1	Housing	Steel	G20Mn5QT, 10213-3		LCC, A352	
2	Welded bonnet	Steel				
2.1	Bonnet	Steel	P285QH, 10222-4			
2.2	Distance ring	Steel	S355J2+N, 10025-2			Q355ND, 1591
3	Spindle	Stainless steel	X8CrNiS18-10, 10088-3		AISI 304	
4	Cone	Steel	115Mn30, 10087			
5	Piston	Steel	115Mn30, 10087			
6	Bolts	Steel	42CrMo4+QT, 10250-3			
7	Thread connection	Stainless steel	X8CrNiS18-9, 10088-3		ANSI 303	
8	Teflon ring	PTFE				
9	External bushing	Steel				
10	Washer	Steel				
11	Cap	Aluminium				
12	Cap sealing	Nylon				
13	Gasket for top module	Grafilit-EM				
14	Cone sealing	PEEK				
15	O-ring cone sealing	EPDM				
16	O-ring Piston sealing	EPDM				
17	Cone screw	Steel				
18	Nord-Lock disc	Steel				
19	Glyd ring for main radial sealing	PTFE				
20	O-ring for main radial sealing	EPDM				
21	Expander	Steel				
22	Ball	Steel				
23	Bushing	Steel				
24	Identification wring	Aluminium				

**FIA-140B 50-100 (2 – 4 in.)**

Figure 9: FIA-140B 50-100 (2 – 4 in.)

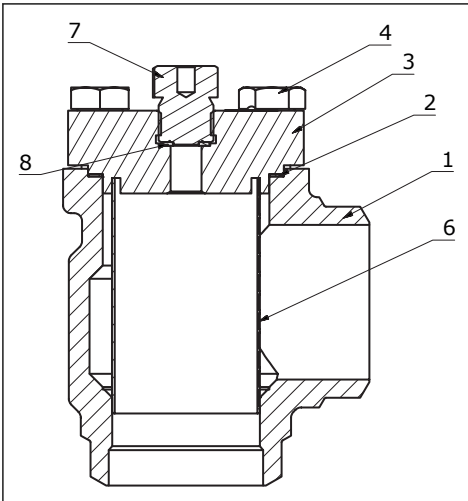

Table 15: Material and part list for DN 50-100

No.	Part	Material	EN	ISO	ASTM
1	Housing	Steel	DN50:P285QH, 10222-4 DN65:P285QH, 10222-4 DN80:G20Mn5QT, 10213-3 DN100:G20Mn5QT, 10213-3		DN50:LF2, A350 DN65:LF2, A350 DN80:LCC, A352 DN100:LCC, A352
2	Gasket	Graflit-EM			
3	Cover	Steel	P275NL1 or 2, 10028-3		
4	Bolts	Steel	42CrMo4+QT, 10250-3		
5	Marking label	Aluminium			
6	Strainer insert	Stainless steel			
7	Pressure relief screw	Stainless steel			
8	Packing washer	Aluminium			

**Dimensions and weights**

**SVA 50 - 100 (2 – 4 in.) in angleway and straightway version with cap**

Table 16: SVA 50 - 100 (2 – 4 in.) in angleway and straightway version with cap

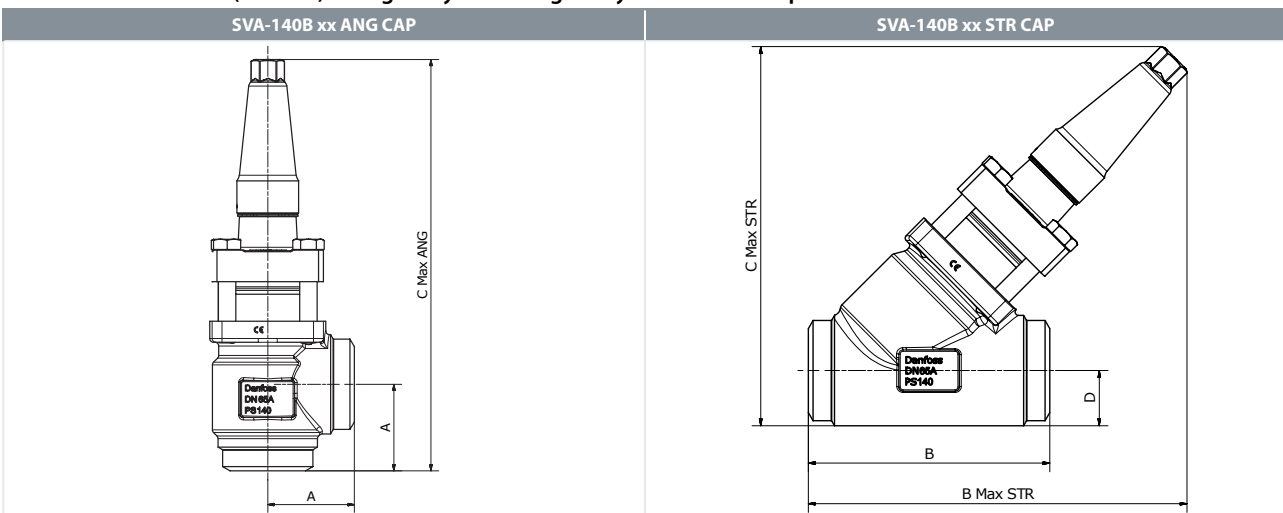

Table 17: SVA 50 - 100 (2 – 4 in.) in angleway and straightway version with cap

Valve size		A	C <sub>max. ANG</sub>	B	D	B <sub>max. STR</sub>	C <sub>max. STR</sub>	Weight [kg]
50	ANG	70	333					7.5
65	ANG	70	333					7.5
80	ANG	90	386					13

## Shut-off valve SVA-140B and Strainer FIA-140B 140 bar (2030 psi) series

Valve size		A	C <sub>max. ANG</sub>	B	D	B <sub>max. STR</sub>	C <sub>max. STR</sub>	Weight [kg]
100	ANG	106	429					22.2
50	STR			176	40	276	276	8.5
65	STR			176	40	276	276	8.5
80	STR			216	48	318	320	14.5
100	STR			264	60	360	370	26.8

### FIA 50 - 100 (2 – 4 in.) in angleway and straightway version with cap

Table 18: FIA 50 - 100 (2 – 4 in.) in angleway and straightway version with cap

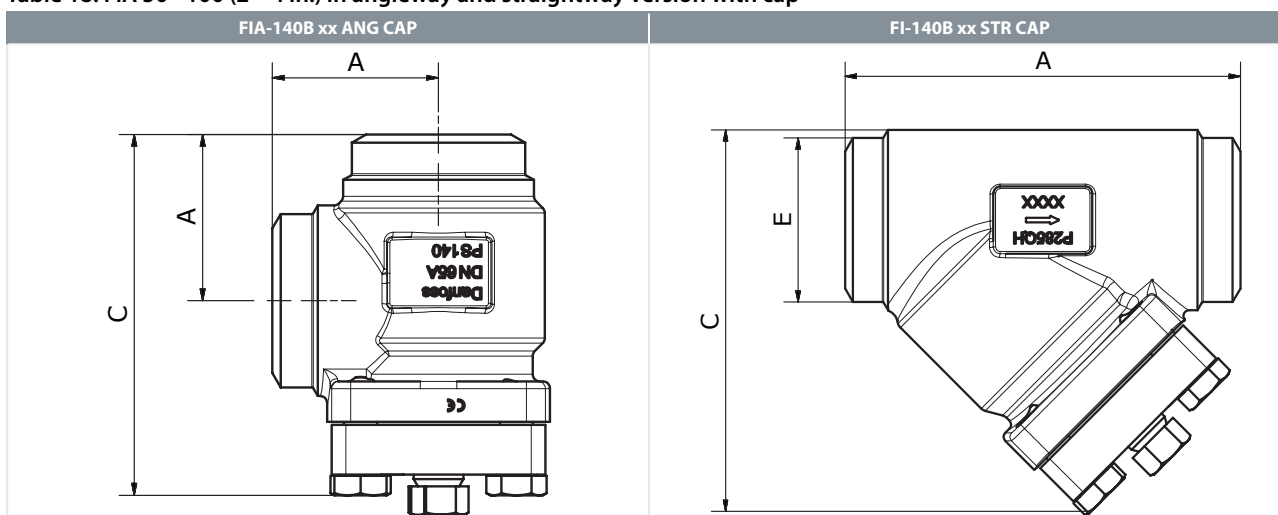

Table 19: FIA 50 - 100 (2 – 4 in.) in angleway and straightway version with cap

Valve size		A	C <sub>max. ANG</sub>	E	C <sub>max. STR</sub>	A <sub>max. STR</sub>	Weight [kg]
50	ANG	70	152				5.05
65	ANG	70	152				5
80	ANG	90	181				8.9
100	ANG	106	219				14.95
50	STR			60	171	176	7.1
65	STR			73	171	176	6.7
80	STR			89	206	216	10.7
100	STR			114	261	264	19.7

## Ordering

**Table 20: Connection sizes**

Size	SVA-140B	FIA-140B
50	A/D, SA/SD	A/D, SA/SD
65	A, D, SA, SD	A, D, SA, SD
80	A/D	A/D
100	A/D	A/D
Connection Note:	A: ANSI B36.10 SCH80	
	D: EN10216-2	
	SA: ASME B16.50	
	SD: EN 1254-5	

**NOTE:**

Please note that the type codes only serve to identify the valves, some of which may not form part of the standard product range. For further information please contact your local Danfoss Sales Company. Code numbers may cover more connection types (e.g. A/D) where standards and tolerances allow for it.

**Table 21: Type codes**

	Size	DN	A	D	SA	SD
Nominal size in mm	50	DN 50 (2")	2"	DN 50	2 1/8"	54
	65	DN 65 (2 1/2")	2 1/2"	DN 65	2 5/8"	64
	80	DN 80 (3")	3"	DN 80		
	100	DN 100 (4")	4"	DN 100		
Connection	A	Butt-weld ANSI (B 36.10 Schedule 80)				
	D	Butt-weld DIN (EN 10216-2)				
	SA	Brazing ASME B16.50, 2 1/8" and 2 5/8"				
	SD	Brazing EN 1254-5, 54 and 64 mm				
Valve housing	ANG	Angle flow				
	STR	Straight flow				
Other equipment	CAP	Cap				

### Ordering SVA-140B valves

**IMPORTANT:**

Where products need to be certified according to specific certification societies or where higher pressures are required, the relevant information should be included at the time of order.

**Table 22: SVA-140B Angleway - Butt-weld ANSI (B 36.10 Schedule 80)**

Size		Type	MWP		Code number
mm	in.		bar	psi	
50	2	SVA-140B Shut Off Valve 50 A/D ANG	140	2030	148B6817
65	2 1/2	SVA-140B Shut Off Valve 65 A ANG	140	2030	148B6819
80	3	SVA-140B Shut Off Valve 80 A/D ANG	140	2030	148B6823
100	4	SVA-140B Shut Off Valve 100 A/D ANG	140	2030	148B6825

**Table 23: SVA-140B Straightway - Butt-weld ANSI (B 36.10 Schedule 80)**

Size		Type	MWP		Code number
mm	in.		bar	psi	
50	2	SVA-140B Shut Off Valve 50 A/D STR	140	2030	148B6818
65	2 1/2	SVA-140B Shut Off Valve 65 A STR	140	2030	148B6820
80	3	SVA-140B Shut Off Valve 80 A/D STR	140	2030	148B6824
100	4	SVA-140B Shut Off Valve 100 A/D STR	140	2030	148B6826

## Shut-off valve SVA-140B and Strainer FIA-140B 140 bar (2030 psi) series

**Table 24: SVA-140B Angleway - Butt-weld DIN (EN 10216-2)**

Size		Type	MWP		Code number
mm	in.		bar	psi	
50	2	SVA-140B Shut Off Valve 50 A/D ANG	140	2030	148B6817
65	2½	SVA-140B Shut Off Valve 65 D ANG	140	2030	148B6821
80	3	SVA-140B Shut Off Valve 80 A/D ANG	140	2030	148B6823
100	4	SVA-140B Shut Off Valve 100 A/D ANG	140	2030	148B6825

**Table 25: SVA-140B Straightway - Butt-weld DIN (EN 10216-2)**

Size		Type	MWP		Code number
mm	in.		bar	psi	
50	2	SVA-140B Shut Off Valve 50 A/D STR	140	2030	148B6818
65	2½	SVA-140B Shut Off Valve 65 D STR	140	2030	148B6822
80	3	SVA-140B Shut Off Valve 80 A/D STR	140	2030	148B6824
100	4	SVA-140B Shut Off Valve 100 A/D STR	140	2030	148B6826

**Table 26: SVA-140B Angleway - Brazing ASME B16.50, 2 1/8" and 2 5/8"**

Size		Type	MWP		Code number
mm	in.		bar	psi	
	2 1/8	SVA-140B Shut Off Valve 50 SA/SD ANG	140	2030	148B6827
	2 5/8	SVA-140B Shut Off Valve 65 SA ANG	140	2030	148B6829

**Table 27: SVA-140B Straightway - Brazing ASME B16.50, 2 1/8" and 2 5/8"**

Size		Type	MWP		Code number
mm	in.		bar	psi	
	2 1/8	SVA-140B Shut Off Valve 50 SA/SD STR	140	2030	148B6828
	2 5/8	SVA-140B Shut Off Valve 65 SA STR	140	2030	148B6830

**Table 28: SVA-140B Angleway - Brazing EN 1254-5, 54 and 64 mm**

Size		Type	MWP		Code number
mm	in.		bar	psi	
54		SVA-140B Shut Off Valve 50 SA/SD ANG	140	2030	148B6827
64		SVA-140B Shut Off Valve 65 SD ANG	140	2030	148B6831

**Table 29: SVA-140B Straightway - Brazing EN 1254-5, 54 and 64 mm**

Size		Type	MWP		Code number
mm	in.		bar	psi	
54		SVA-140B Shut Off Valve 50 SA/SD STR	140	2030	148B6828
64		SVA-140B Shut Off Valve 65 SD STR	140	2030	148B6832

## Ordering FIA-140B valves

**Table 30: FIA-140B Angleway - Butt-weld ANSI (B 36.10 Schedule 80)**

Size		Type	MWP		Code number
mm	in.		bar	psi	
50	2	FIA-140B Filter Housing 50 A/D ANG	140	2030	148B6833
65	2½	FIA-140B Filter Housing 65 A ANG	140	2030	148B6835
80	3	FIA-140B Filter Housing 80 A/D ANG	140	2030	148B6839
100	4	FIA-140B Filter Housing 100 A/D ANG	140	2030	148B6841

**Table 31: FIA-140B Straightway - Butt-weld ANSI (B 36.10 Schedule 80)**

Size		Type	MWP		Code number
mm	in.		bar	psi	
50	2	FIA-140B Filter Housing 50 A/D STR	140	2030	148B6834
65	2½	FIA-140B Filter Housing 65 A STR	140	2030	148B6836
80	3	FIA-140B Filter Housing 80 A/D STR	140	2030	148B6840
100	4	FIA-140B Filter Housing 100 A/D STR	140	2030	148B6842

## Shut-off valve SVA-140B and Strainer FIA-140B 140 bar (2030 psi) series

**Table 32: FIA-140B Angleway - Butt-weld DIN (EN 10216-2)**

Size		Type	MWP		Code number
mm	in.		bar	psi	
50	2	FIA-140B Filter Housing 50 A/D ANG	140	2030	148B6833
65	2½	FIA-140B Filter Housing 65 D ANG	140	2030	148B6837
80	3	FIA-140B Filter Housing 80 A/D ANG	140	2030	148B6839
100	4	FIA-140B Filter Housing 100 A/D ANG	140	2030	148B6841

**Table 33: FIA-140B Straightway - Butt-weld DIN (EN 10216-2)**

Size		Type	MWP		Code number
mm	in.		bar	psi	
50	2	FIA-140B Filter Housing 50 A/D STR	140	2030	148B6834
65	2½	FIA-140B Filter Housing 65 D STR	140	2030	148B6838
80	3	FIA-140B Filter Housing 80 A/D STR	140	2030	148B6840
100	4	FIA-140B Filter Housing 100 A/D STR	140	2030	148B6842

**Table 34: FIA-140B Angleway - Brazing ASME B16.50, 2 1/8" and 2 5/8"**

Size		Type	MWP		Code number
mm	in.		bar	psi	
	2 1/8	FIA-140B Filter Housing 50 SA/SD ANG	140	2030	148B6843
	2 5/8	FIA-140B Filter Housing 65 SA ANG	140	2030	148B6845

**Table 35: FIA-140B Straightway - Brazing ASME B16.50, 2 1/8" and 2 5/8"**

Size		Type	MWP		Code number
mm	in.		bar	psi	
	2 1/8	FIA-140B Filter Housing 50 SA/SD STR	140	2030	148B6844
	2 5/8	FIA-140B Filter Housing 65 SA STR	140	2030	148B6846

**Table 36: FIA-140B Angleway - Brazing EN 1254-5, 54 and 64 mm**

Size		Type	MWP		Code number
mm	in.		bar	psi	
54		FIA-140B Filter Housing 50 SA/SD ANG	140	2030	148B6843
64		FIA-140B Filter Housing 65 SD ANG	140	2030	148B6847

**Table 37: FIA-140B Straightway - Brazing EN 1254-5, 54 and 64 mm**

Size		Type	MWP		Code number
mm	in.		bar	psi	
54		FIA-140B Filter Housing 50 SA/SD STR	140	2030	148B6844
64		FIA-140B Filter Housing 65 SD STR	140	2030	148B6848

## Strainer element

**NOTE:**

Please note that you have to order FIA strainer without element, a strainer element and accessories.

**Table 38: Strainer elements**

FIA size		Strainer insert 150µ	Strainer insert 250µ	Strainer insert 500µ	Pleated Strainer insert 150µ	Pleated Strainer insert 250µ	Pleated Strainer insert 500µ
mm	in.	100 mesh	72 mesh	38 mesh	100 mesh	72 mesh	38 mesh
50	2	148H3131	148H3139	148H3145	148H3180	148H3185	148H3190
65	2½	148H3131	148H3139	148H3145	148H3180	148H3185	148H3190
80	3	148H3119	148H3120	148H3121	148H3181	148H3186	148H3191
100	4	148H3132	148H3140	148H3146	148H3182	148H3187	148H3192

## **Accessories**

**Table 39: Accessories**

Part	Accessory for	Code number
Magnet insert	FIA 65-100	148H3447
Filter bag	FIA 50/65	148H3151
	FIA 80	148H3152
	FIA 100	148H3153
Blind nut with gasket	FIA 50 - 100	148H3450

## Certificates, declarations and approvals

The list contains all certificates, declarations, and approvals for this product type. Individual code number may have some or all of these approvals, and certain local approvals may not appear on the list.

Some approvals may change over time. You can check the most current status at [danfoss.com](http://danfoss.com) or contact your local Danfoss representative if you have any questions.

**Table 40: Certificates, declarations and approvals**

File name	Document type	Document topic	Approval Authority
033F0685.AN	EU Declaration	PED	Danfoss
033F0691.AH	Manufacturers Declaration	RoHS	Danfoss

**Table 41: Certificates and declarations**

	SVA/FIA-140B valves are approved according to the European standard specified in the Pressure Equipment Directive and are CE marked.
---	--

**NOTE:**

For further details / restrictions - see Installation guide.

**Table 42: PED Categorization**

Nominal bore	DN 50/65	DN 80	DN 100
Classified for	Fluid group 2		
Category	I	I	I

## Online support

Danfoss offers a wide range of support along with our products, including digital product information, software, mobile apps, and expert guidance. See the possibilities below.

### The Danfoss Product Store



The Danfoss Product Store is your one-stop shop for everything product related—no matter where you are in the world or what area of the cooling industry you work in. Get quick access to essential information like product specs, code numbers, technical documentation, certifications, accessories, and more.

Start browsing at [store.danfoss.com](https://store.danfoss.com).

### Find technical documentation



Find the technical documentation you need to get your project up and running. Get direct access to our official collection of data sheets, certificates and declarations, manuals and guides, 3D models and drawings, case stories, brochures, and much more.

Start searching now at [www.danfoss.com/en/service-and-support/documentation](https://www.danfoss.com/en/service-and-support/documentation).

### Danfoss Learning



Danfoss Learning is a free online learning platform. It features courses and materials specifically designed to help engineers, installers, service technicians, and wholesalers better understand the products, applications, industry topics, and trends that will help you do your job better.

Create your Danfoss Learning account for free at [www.danfoss.com/en/service-and-support/learning](https://www.danfoss.com/en/service-and-support/learning).

### Get local information and support



Local Danfoss websites are the main sources for help and information about our company and products. Find product availability, get the latest regional news, or connect with a nearby expert—all in your own language.

Find your local Danfoss website here: [www.danfoss.com/en/choose-region](https://www.danfoss.com/en/choose-region).

### Spare Parts



Get access to the Danfoss spare parts and service kit catalog right from your smartphone. The app contains a wide range of components for air conditioning and refrigeration applications, such as valves, strainers, pressure switches, and sensors.

Download the Spare Parts app for free at [www.danfoss.com/en/service-and-support/downloads](https://www.danfoss.com/en/service-and-support/downloads).

### Coolselector®2 - find the best components for you HVAC/R system



Coolselector®2 makes it easy for engineers, consultants, and designers to find and order the best components for refrigeration and air conditioning systems. Run calculations based on your operating conditions and then choose the best setup for your system design.

Download Coolselector®2 for free at [coolselector.danfoss.com](https://coolselector.danfoss.com).

### Danfoss A/S

Climate Solutions • [danfoss.com](https://danfoss.com) • +45 7488 2222

Any information, including, but not limited to information on selection of product, its application or use, product design, weight, dimensions, capacity or any other technical data in product manuals, catalogues descriptions, advertisements, etc. and whether made available in writing, orally, electronically, online or via download, shall be considered informative, and is only binding if and to the extent, explicit reference is made in a quotation or order confirmation. Danfoss cannot accept any responsibility for possible errors in catalogues, brochures, videos and other material. Danfoss reserves the right to alter its products without notice. This also applies to products ordered but not delivered provided that such alterations can be made without changes to form, fit or function of the product.

All trademarks in this material are property of Danfoss A/S or Danfoss group companies. Danfoss and the Danfoss logo are trademarks of Danfoss A/S. All rights reserved.