



Data sheet

QTL & AB-QM set - QTL 45-60 2m capillary tube with AB-QM DN 15

Description



QTL is self-acting thermostatic actuator primarily for use for temperature control of small hot water cylinders.

Main features:

- Thermostat
- Setting range: 45-60 °C
- 2 meter capillary tube length
- Valve AB-QM, DN 15
- PN 16
- Max media temp: 120 °C
- Max differential pressure: 6 bar (600 kPa)
- Housing material: DZR brass
- Connection: External thread ISO228/1

Disposal

- Small compact thermostat
- Fast and reliable thermostat / valve connection
- Automatic flow limitation to match energy demand
- Easy valve selection and commissioning
- Easy to adjust the required max flow

Ordering

AB-QM QTL set DN 15 45-60/2m

Picture	Type	Code No.
	QTL Thermostat 45-60 2m capillary tube	003L3535
	AB-QM 15 G 3/4A, 0.09-0.45 m³/h	
	AB-QM, union connection, DN 15	

Service part

Picture	Setting range	Valve AB-QM	Code No.
	QTL thermostatic actuator 45-60°C	*	003L3534

* compatible only with old range of AB-QM codes 003Z1261, 003Z1211, 003Z1262, 003Z1212, 003Z1213

Accessories

Picture	Type	Connection	Code No.
	Immersion pocket Cu	Rp 1/2 x M14 - ø12 x 100 mm	003Z0391
	Housing for sensor stuffing box	G 1/2"	013U8102
	Sensor stuffing box / pocket kit	M14x1	013U0292
	Union connection (1 pcs)	DN 15 Rp 1/2	003Z0232
	Tailpiece connection – welding (1 pcs)	DN 15	003Z0226

Application

Thermostatic temperature controllers for single-family houses and flats are used to control the flow temperature in storage domestic hot water and heating systems. With their fast opening and closing, they protect the heating coil from scaling and ensure a long lifetime for the equipment installed in the system.

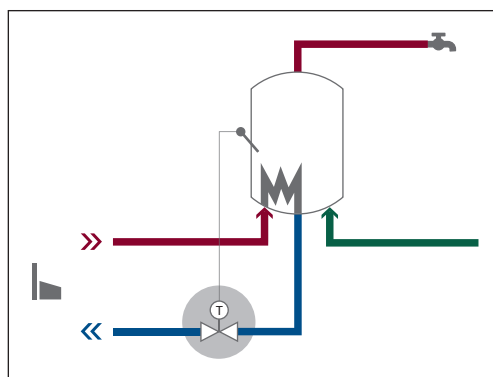

Sizing example

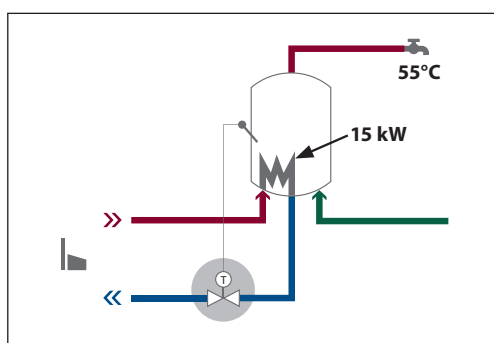

Required flow Q m³/h

$$Q = 0.86 \times P / \Delta T$$

$$= 0.86 \times 15 / 40$$

$$= 0.3 \text{ m}^3/\text{h}$$

Selected valve:

AB-QM, DN 15, Q_{nom} = 0.45 m³/h

Nominal diameter		DN	15
Flow range	Q _{nom} (100 %)	l/h	450

Given data

DHW temp	55°C
Heating coil capacity	15 kW
Temp diff flow - return	40°K
Available Δp valve	2 bar

Thermostat setting

Valve presetting = 72%

P-band ≈ 7 °C

DHW temp = 55 °C - 7 °C = 48 °C

Thermostat setting: 2

Required data

Valve DN	??
Valve presetting setting	??
Thermostat setting	??

Thermostat setting

DHW temp	55°C
Valve presetting	72%
Thermostat setting	2 ¹⁾

¹⁾ The setting temperature according to table on page 3 is indicative.

Technical Data

General data		
Setting range	°C	45 ... 60
P-band ¹⁾		5
Max adm temperature at sensor		90
Capillary tube length	m	2.2
Material		
Housing	DZR Brass (CuZn36Pb2As - CW 602N)	
Cone and diaphragm support	MPPE (Noryl)	
Main spindle	(CW 614N) Zn39Pb3	
Temperature sensor	Copper, mat. No. 2.0090	
Adapter	DN 10-20	CuZn39Pb3 (CW 614N), coated with Cu Zn8B
Nut		

¹⁾ with relevant AB-QM, at 50 % flow setting

Technical Data (continuous) AB-QM (thread version)

Nominal diameter		DN	15
Flow range	Q _{nom} (100 %) ¹⁾	l/h	450
Setting range ²⁾		%	20-120
Diff. pressure ^{3), 4)}	Δp_{min} ⁶⁾	kPa	16-400/600 ⁶⁾
	Δp_{max} ⁶⁾		
Pressure stage		PN	16
Control range			1:1000
Control valve's characteristic			Linear
Leakage rate with recommended actuators			No visible leakage
For shut off function			Acc. to ISO 5208 class A - no visible leakage
Flow medium			Water and water mixture for closed heating and cooling systems according to plant type I for DIN EN 14868. When used in plant Type II for DIN EN 14868 appropriate protective measures are taken. The requirements of VDI 2035, part 1 + 2 are observed.
Medium temperature		°C	-10 ... +120
Storage and transport temp.			-40 ... 70
Stroke		mm	2.25
Connection	ext. thread (ISO 228/1)		G ¾ A
	actuator		M30 × 1.5
Materials in the water			
Valve bodies		DZR Brass (CuZn36Pb2As - CW 602N)	
Membranes and O-rings		EPDM	
Springs		W.Nr. 1.4568, W.Nr. 1.4310	
Cone (Pc)		W.Nr. 1.4305	
Seat (Pc)		EPDM	
Cone (Cv)		CuZn40Pb3 - CW 614N	
Seat (Cv)		DZR Brass (CuZn36Pb2As - CW 602N)	
Screw		Stainless Steel (A2)	
Flat gasket		NBR	
Sealing agent (only for valves with test plugs)		Dimethacrylate Ester	
Materials out of the water			
Plastic parts		PA	
Insert parts and outer screws		CuZn39Pb3 - CW 614N; W.Nr. 1.4310; W.Nr. 1.4401	

¹⁾ Factory setting of the valve is done at nominal setting range.

²⁾ Regardless of the setting, the valve can modulate below 1 % of set flow.

³⁾ $\Delta p = (P1-P3) min\sim max$

⁴⁾ When set above 100 %, minimum starting pressure needed is higher.

⁵⁾ When set above 100 %, it can be used as a flow limiter only.

⁶⁾ In case AB-QM is used above 400 kPa differential pressure contact Danfoss design center to assure proper design.

Pc - pressure controller part
Cv - Control valve part

Note: According suitability and usage especially in not oxygen tight systems please mind the instructions given by the coolant producer.

Settings

AB-QM DN 10-20 (45-60 °C)

Temperature setting	P-band	QT Sensor setting (turns)							
		0	1	2	3	4	5	6	
AB-QM (flow setting)	20%	≈ 2 °C	48.0	50.5	53.0	55.5	58.0	60.5	63.0
	30%	≈ 3 °C	47.0	49.5	52.0	54.5	57.0	59.5	62.0
	40%	≈ 4 °C	46.0	48.5	51.0	53.5	56.0	58.5	61.0
	50%	≈ 5 °C	45.0	47.5	50.0	52.5	55.0	57.5	60.0
	60%	≈ 6 °C	44.0	46.5	49.0	51.5	54.0	56.5	59.0
	70%	≈ 7 °C	43.0	45.5	48.0	50.5	53.0	55.5	58.0
	80%	≈ 8 °C	42.0	44.5	47.0	49.5	52.0	54.5	57.0
	90%	≈ 9 °C	41.0	43.5	46.0	48.5	51.0	53.5	56.0
100%	≈ 10 °C	40.0	42.5	45.0	47.5	50.0	52.5	55.0	

QTL temperature setting depends on AB-QM flow setting. The values in the table indicate the open position of the thermostat. Please note that the attached table is indicative and will vary depending on the application. It is to be used as a guidance only. For exact temperature verification temperature needs to be measured at reference point and the sensor setting adjusted accordingly.

It is necessary to set the AB-QM according to required setting before the thermostat is mounted. It is recommended to set AB-QM between 30 and 70 % flow setting. QTL thermostat is set to the desired setting by hand. When minimum or maximum setting is required, QTL setting knob is to be moved slightly in opposite direction to ensure optimal performance of the thermostat.

Data sheet

QTL 45-60 2m capillary tube with AB-QM DN 15

Design

1. Setting knob
2. Adapter
3. AB-QM valve
4. Hot-water pipe
5. Temperature sensor

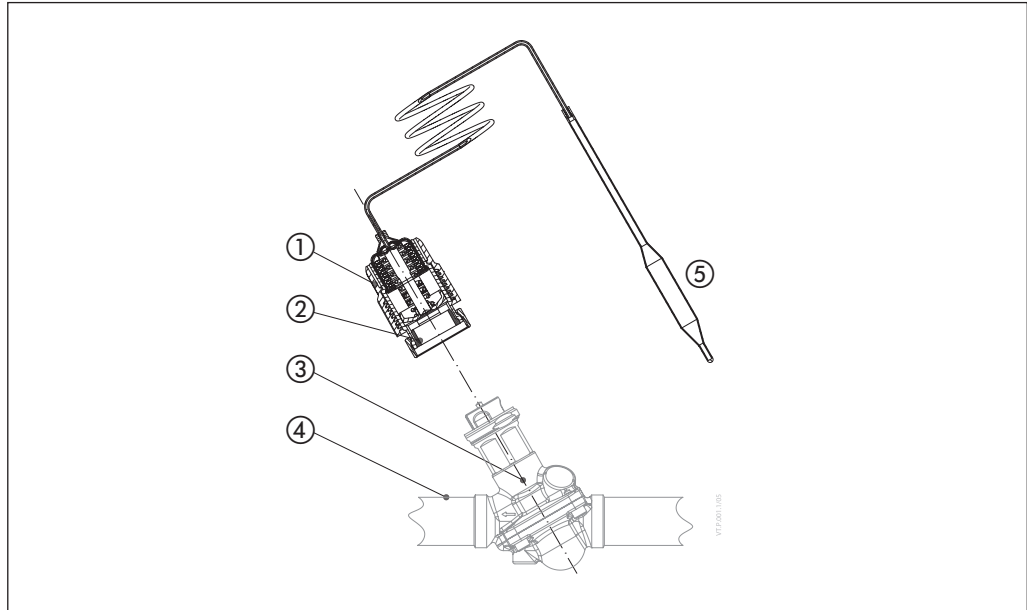

Dimensions

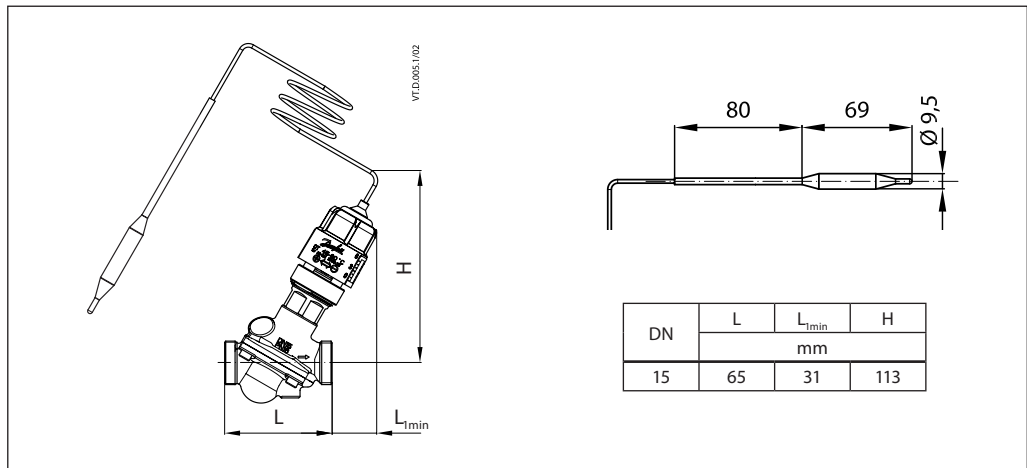

Danfoss A/S

Climate Solutions • climatesolutions.danfoss.com • +45 7488 2222 • E-Mail: climatesolutions@danfoss.com

Any information, including, but not limited to information on selection of product, its application or use, product design, weight, dimensions, capacity or any other technical data in product manuals, catalogues descriptions, advertisements, etc. and whether made available in writing, orally, electronically, online or via download, shall be considered informative, and is only binding if and to the extent, explicit reference is made in a quotation or order confirmation. Danfoss cannot accept any responsibility for possible errors in catalogues, brochures, videos and other material. Danfoss reserves the right to alter its products without notice. This also applies to products ordered but not delivered provided that such alterations can be made without changes to form, fit or function of the product.

All trademarks in this material are property of Danfoss A/S or Danfoss group companies. Danfoss and the Danfoss logo are trademarks of Danfoss A/S. All rights reserved.