

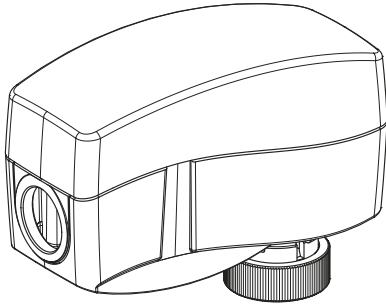

Operating Guide

AMI 120 NL-1 / 73694420

AMI 120 NL-1



Stem Travel	5 mm
Travel Speed	10 (12) s/mm

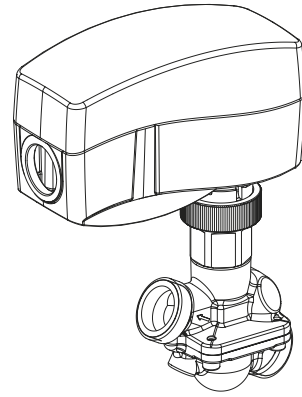

AMI 120 NL-1+
AB-QM

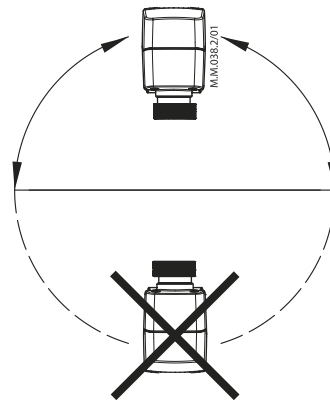
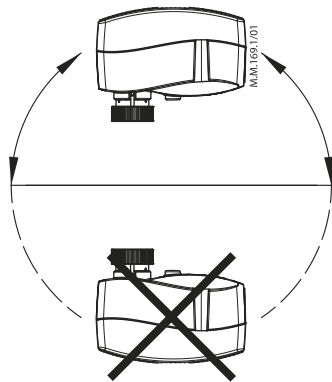
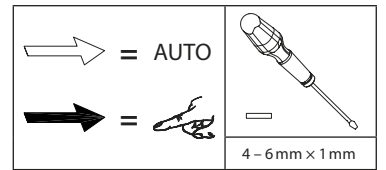
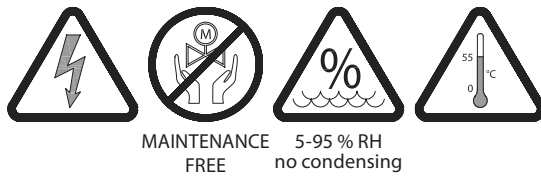

AMI 120 NL-1

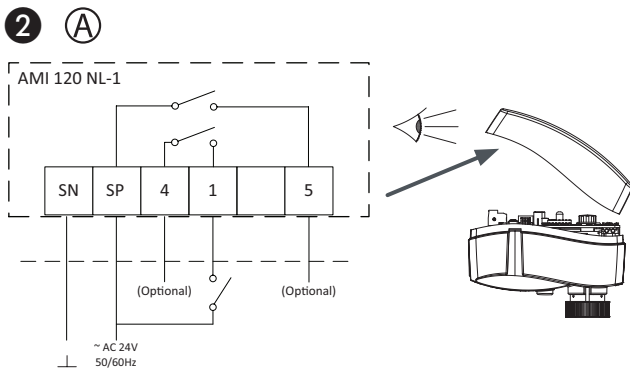

Note: Direction of actuator stem movement is defined with jumper position. Look bottom chapter "Travel Direction".

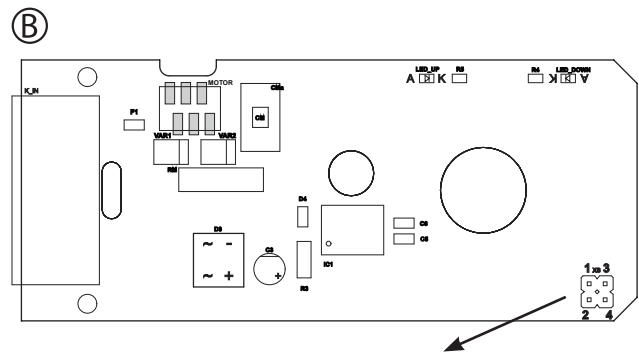
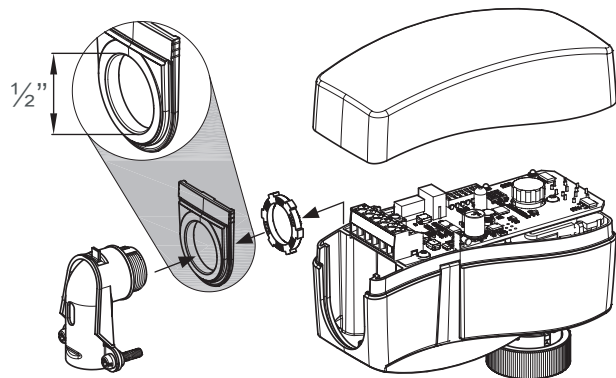

1 3 Jumper Position "A" (Factory Setting)



"On" at terminal block position "1": Actuator drives up and valve opens, optional terminal 4 closes.

"Off" at terminal block position "1": Actuator drives down and valve closes, optional terminal 5 closes.

1 3 Jumper Position "B"



"On" at terminal block position "1": Actuator drives down and valve closes, optional terminal 4 closes.

"Off" at terminal block position "1": Actuator drives up and valve opens, optional terminal 5 closes.

3

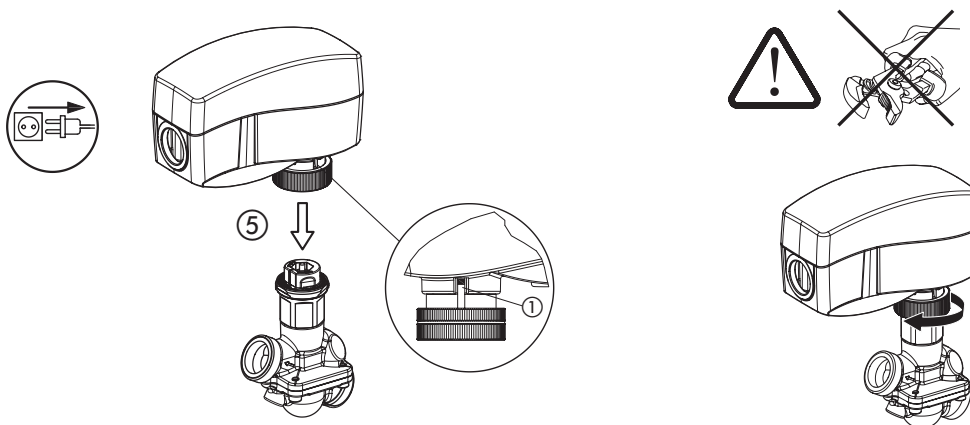

4

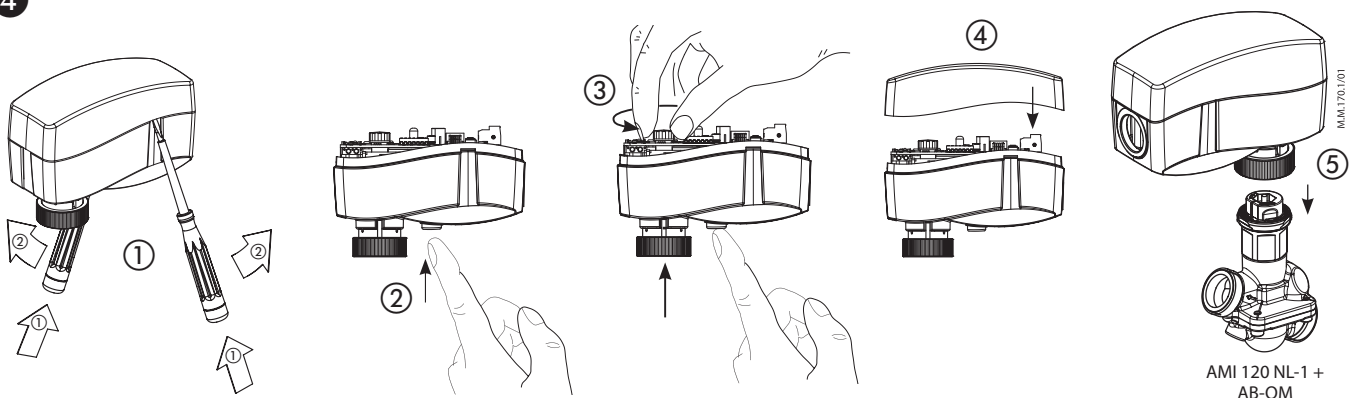

ENGLISH

Safety Notes



To avoid personal injury and damage to the device or other property, it is necessary to read and follow these instructions carefully.

Assembly, start-up, and maintenance work must be performed by qualified and authorized personnel.

Comply with the instructions of the system manufacturer or system operator.



Do not remove the cover before the power supply is switched off.

Mounting Position ①

The actuator should be mounted with the valve stem in either a horizontal position or pointing upwards.

Wiring ②

Ⓐ



AC 24V
Connect via Class 2 (North America) or Safety Extra-Low Voltage (SELV) (Europe). Failure to comply can lead to equipment damage or personal injury.



Switch off power before wiring the actuator!

1. Make all wiring connections in accordance with local, national, or regional regulations.
2. For applications requiring conduit, a field supplied 1/2" trade size electrician's fitting and lock nut can be mounted in the actuator enclosure. Use flexible metallic tubing or its equivalent with the field supplied fitting.
3. Insert wiring material through the removable plug or conduit fitting, and connect to the terminal block using the applicable wiring diagram ②.
4. Optionally, end position feedback is available on terminal 4 and terminal 5, which indicates actuator's end position travel. Both contacts are normally open.

Jumper position setting

Ⓑ



Do not remove the cover before the power supply is fully switched off.

• The Jumper is factory set in position "A"

With the jumper in position "A", an "ON" command at position 1 of the terminal block will cause the actuator spindle to extend (valve closes). An "OFF" command will cause the spindle to retract (valve opens)

• Moving the jumper to position "B" will reverse the actuator's action

With the jumper in position "B", an "ON" command at position 1 of the terminal block will cause the actuator spindle to retract (valve opens). An "OFF" command will cause the spindle to extend (valve closes).

Installation ③

1. Check the valve neck. The actuator should be in the full up position ① (factory setting). If it is not, refer to the manual override instructions and reposition the actuator to its full up position ③①.
2. The actuator is fixed to the valve body by means of a ribbed nut which requires no tools for mounting. The ribbed nut should be hand tightened only.

Manual override ④

(for service purposes only)



Do not use the manual override if power is connected!

- Remove cover ①
- Press and hold the button (on the bottom side of the actuator) ② during manual override ③
- Replace cover ④
- Install actuator on valve ⑤

Remark:

A 'click' sound after energizing the actuator indicates that the gear wheel has jumped into normal position.



Don't dismount the actuator from the valve when it is in a stem down position!

If dismounted in a stem down position, there is a high risk that the actuator gets stuck.



ІМПОРТЕР:

UA: ТОВ з ІІ «Данфосс ТОВ», вул. Вікентія Хвойки, 15/15/6, м. Київ, 04080, Україна

Danfoss A/S

Climate Solutions • danfoss.com • +45 7488 2222

Any information, including, but not limited to information on selection of product, its application or use, product design, weight, dimensions, capacity or any other technical data in product manuals, catalogues descriptions, advertisements, etc. and whether made available in writing, orally, electronically, online or via download, shall be considered informative, and is only binding if and to the extent, explicit reference is made in a quotation or order confirmation. Danfoss cannot accept any responsibility for possible errors in catalogues, brochures, videos and other material. Danfoss reserves the right to alter its products without notice. This also applies to products ordered but not delivered provided that such alterations can be made without changes to form, fit or function of the product.

All trademarks in this material are property of Danfoss A/S or Danfoss group companies. Danfoss and the Danfoss logo are trademarks of Danfoss A/S. All rights reserved.
