



Data sheet

Actuator 2 point, ON/OFF control AMI 120 NL-1

Description



The AMI 120 NL-1 is a 2 point (ON/ OFF), 3 wire actuator used with the AB-QM pressure independent control valves installed on hot or chilled water system applications. This actuator is installed on AB-QM valve sizes ranging from 1/2" to 1- 1/4". The AB-QM assembly is suitable for

installation within fan coil units, VAV, induction units or additional units that require combined balancing and valve control, which could be located within enclosures or plenum rated spaces.

As a 3 wire actuator, it receives constant power to travel to its default position and upon receipt of input signal will travel in the opposite direction. Designed within the actuator is an overload and gap function to prevent unnecessary travel from the actuator.

Main data:

- 2-point, ON/ OFF, 3 wires required
- Force switch-off at stem down position prevents overload of actuator and valve
- Gap function detection on stem up travel
- No tools required for mounting
- Maintenance free during lifetime
- Low noise operation
- 1/2" Conduit hole, removable plate
- Wiring terminal block
- In accordance with UL 2043 for plenum installation
- UL listed

Ordering

Type	Supply voltage	Speed	Code No.
AMI 120 NL-1	24VAC	10 s/mm @ 60Hz (12 s/mm @ 50Hz)	082H5003

Technical data

Power supply	V	24 AC; +10%... -15%
Electrical Connection	"	1/2 electrical conduit, wiring terminal block
Power consumption	VA	1 VA
Frequency	Hz	50 / 60
Control Input		ON/OFF, 3-wire
Output Signal		End travel position feedback
Actuator Force	lbf (N)	45.0 (200)
Max. Stem Travel	mm	5
Travel Speed		12s/mm @ 50Hz, 10s/mm @ 60Hz
Max. Medium Temperature	°F (°C)	248 (120)
Ambient temperature		32 to 131 (0 to 55)
Humidity		5 to 95% RH, noncondensing
Weight	lb (kg)	0.66 (0.3)

	USA	UL Listed, CCN XABE, File E480529; to ANSI/UL 60730-1 and ANSI/ UL 60730-2-14 Investigated and approved for plenum use in accordance with UL 2043
	Canada	UL listed, CCN XABE7, File E480529; to CAN/CSA-E60730-1:13 and CAN/CSA-E60730-2-14:13
	Europe	CE Mark - Danfoss declares that this product complies with all relevant CE-marking directives

Installation

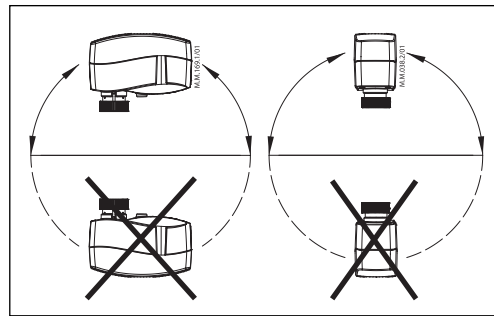

Mechanical

The actuator should be mounted with the valve stem in either horizontal position or pointing upwards.

The actuator is fixed to the valve body by means of a mounting ring which requires no tools for mounting. The ring should be tightened by hand.

Electrical

Important: Prior to energizing the actuator should be assembled to the AB-QM.

Wiring

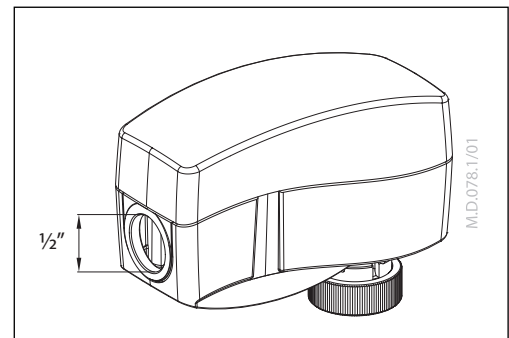
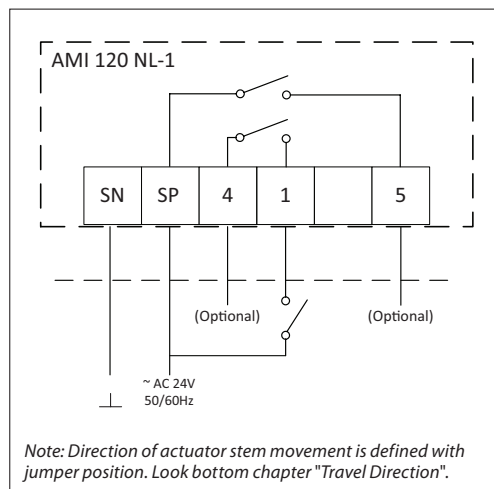

A field supplied 1/2" trade size electrician's fitting and lock nut can be mounted to the actuator enclosure. Insert wiring material through the removable plug or conduit fitting, and wire connection to the terminal block.

Travel Direction

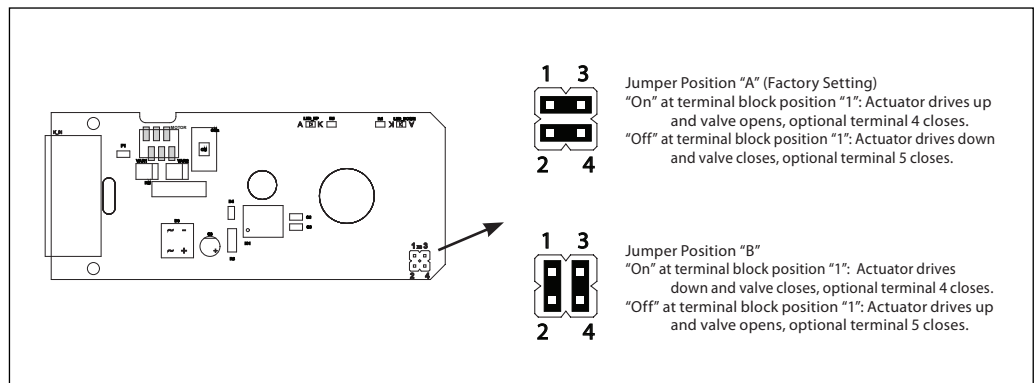

Disposal

The actuator must be dismantled and the elements sorted into various material groups before disposal.

Commissioning

The factory position of the actuator spindle is in a full stem up position allowing easier mechanical connection of the actuator on the valve.

Installation and commissioning procedure
(if required)



Do not touch anything on the PCB! Before removing the cover in need of hand operation with Allen key power supply must be disconnected. Lethal voltage!

1. Check the valve neck. The actuator should be in the full up position (factory setting). If it is not, manually reposition the actuator to its full up position.
2. The actuator is fixed to the valve body by means of a ribbed nut which requires no tools for mounting. The ribbed nut should be hand tightened only.
3. For applications requiring conduit, a field supplied 1/2" trade size electrician's fitting and lock nut can mounted in the actuator enclosure. Make all wiring connections in accordance with local, national, or regional regulations.
4. Insert wiring material through the removable plug or conduit fitting, and connect to the terminal block according to the wiring diagram - see page 2.

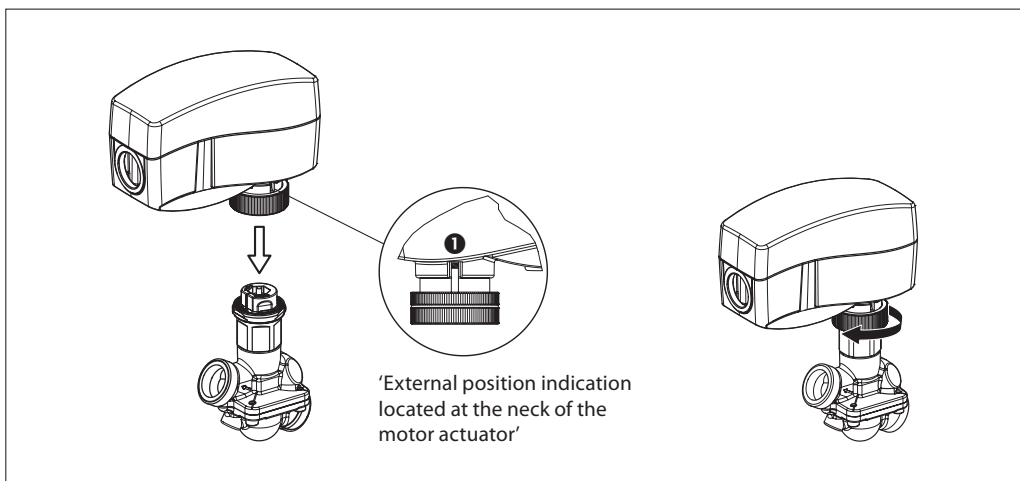

Manual override
(for service purposes only)



Caution:
Do not manually operate the drive under power!

- Remove cover ①
- Press and hold the button ② (on the bottom side of the actuator) during manual override ③
- Replace cover ④
- Install actuator on valve ⑤

Remark:

A "click" sound after energizing the actuator means that the gear wheel has jumped into normal position.

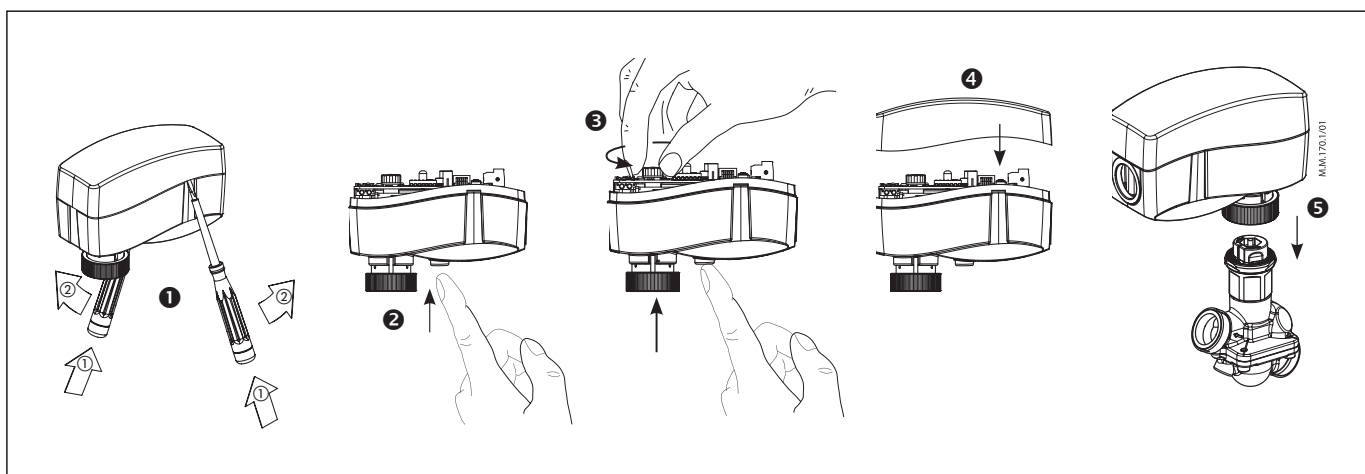

Data sheet

Actuator 2 point, ON/OFF control AMI 120 NL-1

Dimensions (mm)

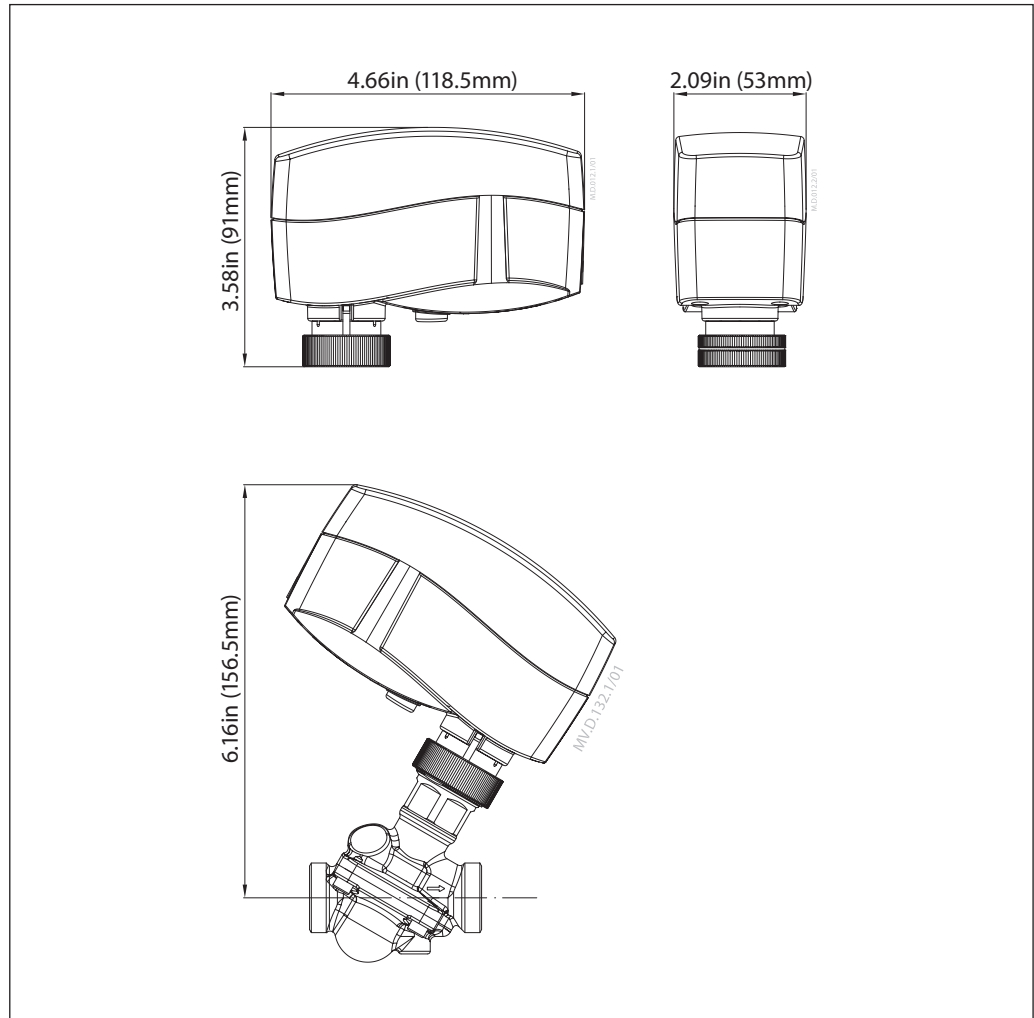

Danfoss A/S

Heating Segment • heating.danfoss.com • +45 7488 2222 • E-Mail: heating@danfoss.com

Danfoss can accept no responsibility for possible errors in catalogues, brochures and other printed material. Danfoss reserves the right to alter its products without notice. This also applies to products already on order provided that such alterations can be made without subsequent changes being necessary in specifications already agreed. All trademarks in this material are property of the respective companies. Danfoss and all Danfoss logotypes are trademarks of Danfoss A/S. All rights reserved.