



Data sheet

Pressure reduction controller (PN 16, 25, 40) AFD 2 / VFG 22(1)

Description



virtus.danfoss.com



The controller is a self-acting pressure reduction controller primarily for use in district heating systems. Direct operated, reliable and high precise controller closes on rising pressure.

The controller has a control valve, an actuator with one control diaphragm and spring for pressure setting.

Further on two valve versions are available:

- VFG 22 with metallic sealing cone
- VFG 221 with soft sealing cone

Remote network balancing optimization function.

Together with Danfoss intelligent electrical actuator AMEi 6 iNET, remote adjustment of the pressure is enabled.

Main data:

- DN 65-250
- k_{vs} 60-800 m³/h
- PN 16, 25, 40
- Setting range:
0.1-0.35 bar / 0.1-1 bar / 0.5-1.5 bar /
1-2.5 bar / 1.5-4 bar / 1-3 bar / 1.5-5 bar /
3-8,5 bar/3-12 bar/8-16 bar
- Temperature:
– Circulation water / glycolic water up to 30%:
2 ... 150°C
- Connections:
– Flange

Ordering

Example 1:
Pressure reduction controller, for water, DN 65, k_{vs} , PN 16, metallic sealing, setting range 1,5-5 bar, T_{max} 150 °C, flange

- 1x VFG 22 DN 65 valve
Code no: . . .
- 1x AFD 2 actuator
Code no: . . .
- 1x Impulse tube set AF
Code no: . . .

Products will be delivered separately.

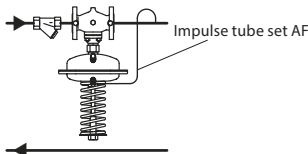

VFG 22 Valve (metallic sealing cone)

Picture	DN (mm)	k_{vs} (m ³ /h)	Connections	T_{max} (°C)	Code No.		
					PN 16	PN 25	PN 40
	65	60	Flanges acc. to EN 1092-1	150	065B5500	065B5507	065B5514
	80	80			065B5501	065B5508	065B5515
	100	160			065B5502	065B5509	065B5516
	125	250			065B5503	065B5510	065B5517
	150	380			065B5504	065B5511	065B5518
	200	650			065B5505	065B5512	065B5519
	250	800	065B5506	065B5513	065B5520		

VFG 221 Valve (soft sealing cone)

Picture	DN (mm)	k_{vs} (m ³ /h)	Connections	T_{max} (°C)	Code No.		
					PN 16	PN 25	PN 40
	65	60	Flanges acc. to EN 1092-1	150	065B5521	065B5528	065B5535
	80	80			065B5522	065B5529	065B5536
	100	160			065B5523	065B5530	065B5537
	125	250			065B5524	065B5531	065B5538
	150	380			065B5525	065B5532	065B5539
	200	650			065B5526	065B5533	065B5540
	250	800			065B5527	065B5534	065B5541

Ordering (continuous)

AFD 2 Actuator

Picture	Setting range (bar)	Possible combinations with DN							Actuator size (cm ²)	Spring colour	Code No.	
		65	80	100	125	150	200	250			PN 16	PN 40
	8-16	✓	✓	✓	✓	-	-	-	32	black ¹⁾	-	003G5634
	3-12	✓	✓	✓	✓	-	-	-	32	red	003G5625	003G5635
	3-8.5	✓	✓	✓	✓	-	-	-	80	black ¹⁾	-	003G5624
	1.5-5	✓	✓	✓	✓	-	-	-	80	red	003G5626	003G5636
	1-3	✓	✓	✓	✓	-	-	-	80	yellow	003G5627	003G5637
	1.5-4	✓	✓	✓	✓	✓	✓	✓	160	black ¹⁾	003G5628	003G5638
	1-2.5	✓	✓	✓	✓	✓	✓	✓	160	red	003G5629	003G5639
	0.5-1.5	✓	✓	✓	✓	-	-	-	160	yellow	003G5630	003G5640
	0.4-1.5	✓	✓	✓	✓	✓	✓	✓	320	red	003G5631	003G5641
	0.1-1	✓	✓	✓	✓	✓	✓	✓	320	orange	003G5632	003G5642
	0.1-0.35	✓	✓	✓	✓	✓	✓	✓	640	yellow	003G5633	003G5643

Accessories

Picture	Type designation	Description	Connections	Code No.
	Impulse tube set AF	- 1x Copper tube Ø10 x 1 x 1500 mm - 1x compression fitting for imp. tube connection to pipe (G ¼) - 2x socket	-	003G1391
	Compression fitting ²⁾	For impulse tube Ø10 connections to controller	G ¼	003G1468
	Shut off valve	For impulse tube Ø10	-	003G1401
	Static throttle valve			065B2909
	Dynamic throttle valve ³⁾	For impulse tube Ø10 / connection to pressure actuator	G ¼	003G1771
	Adapter	new AFD 2-old VFG	DN 15-250	003G1780
	AMEi 6 iNET el. actuator 230 V	Intelligent Δp actuator with iNET function		003G4302
	AMEi 6 iNET el. actuator 24 V			003G4303

¹⁾ Combination with AMEi 6 not possible

²⁾ Consist of a nipple, compression ring and nut

³⁾ Available in 2022

Service kits

Picture	Type	k _{vs} (m ³ /h)	PN	DN	Code No.
	Pressure control insert VFG/Q 22	60	16/25/40	65	003G1800
		80		80	003G1801
		160		100	003G1802
		250		125	003G1803
		380		150	003G1804
		650		200	003G1805
		800		250	003G1806
		60		65	003G1807
	Pressure control insert VFG/Q 221	80		80	003G1808
		160		100	003G1809
		250		125	003G1810
		380		150	003G1811
		650		200	003G1812
		800		250	003G1813
	Pressure stuffing box VFG/Q 221			65-125	003G1730
				150-250	003G1731

Technical data

Valve

Nominal diameter		DN	65	80	100	125	150	200	250	
k _{vs} value		m ³ /h	60	80	160	250	380	650	800	
Leakage acc. to standard IEC 534 (% of k _{vs})	VFG 22	≤ 0.03						≤ 0.05		
	VFG 221	≤ 0.01								
Nominal pressure		PN	16, 25, 40							
Max. differential pressure	PN 16	bar	16			15	12	10		
	PN 25, 40		20							
Pressure relieve system		Chamber relieved								
Media		Circulation water / glycolic water up to 30%								
Media pH		Min. 7, max. 10								
Media temperature	VFG 22(1)	°C	2 ... 150							
Connections		Flange								
Materials										
Valve body	PN 16	Grey cast iron EN-GJL-250 (GG-25)								
	PN 25	Ductile iron EN-GJS-400 (GG-40.3)								
	PN 40	Cast steel GP240GH (GS-C 25)								
Valve seat		Stainless steel, mat. No. 1.4021								
Valve cone		Stainless steel, mat. No. 1.4021								
Sealing	VFG 22	Metal								
	VFG 221	EPDM								

AFD 2 Actuator

Actuator size	cm ²	32	80	160	320	640					
Max. operating pressure	bar	40									
Diff. pressure setting ranges and spring colours	bar	black	red	red	yellow	black ¹⁾	red	yellow	red	orange	yellow
		8-16	3-12	1.5-5	1-3	1.5-4	1-2.5	0.5-1.5	0.4-1.5	0.1-1	0.1-0.35
For valve DN		65-125			65-250	65-100	65-250	65-250			
Materials											
Actuator housing		Steel, mat. No. 1.0345, zinc plated									
Control diaphragm		EPDM (fibre enforced)									

¹⁾ Combination with AMEi 6 not possible
Actuator and impulse tubes minimum temperature is 2 °C to prevent media from freezing

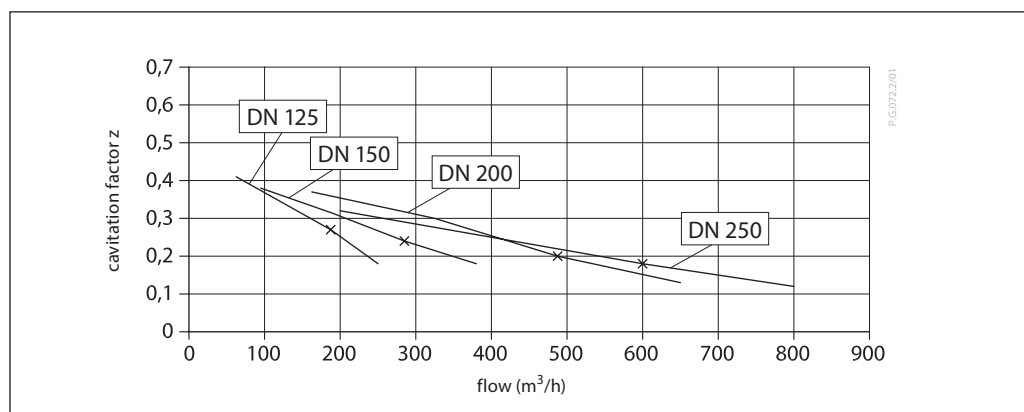
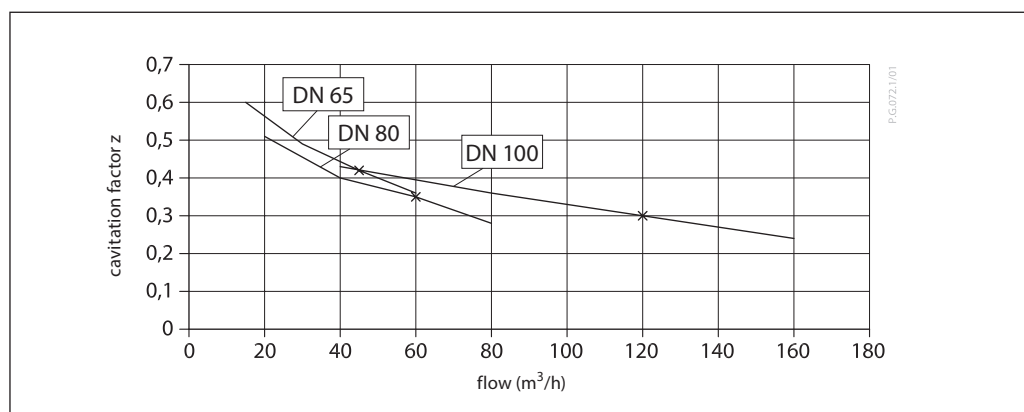

Operating area

Maximum allowed differential pressure over the controller (Δp_{max}) at different cavitation factors (z)

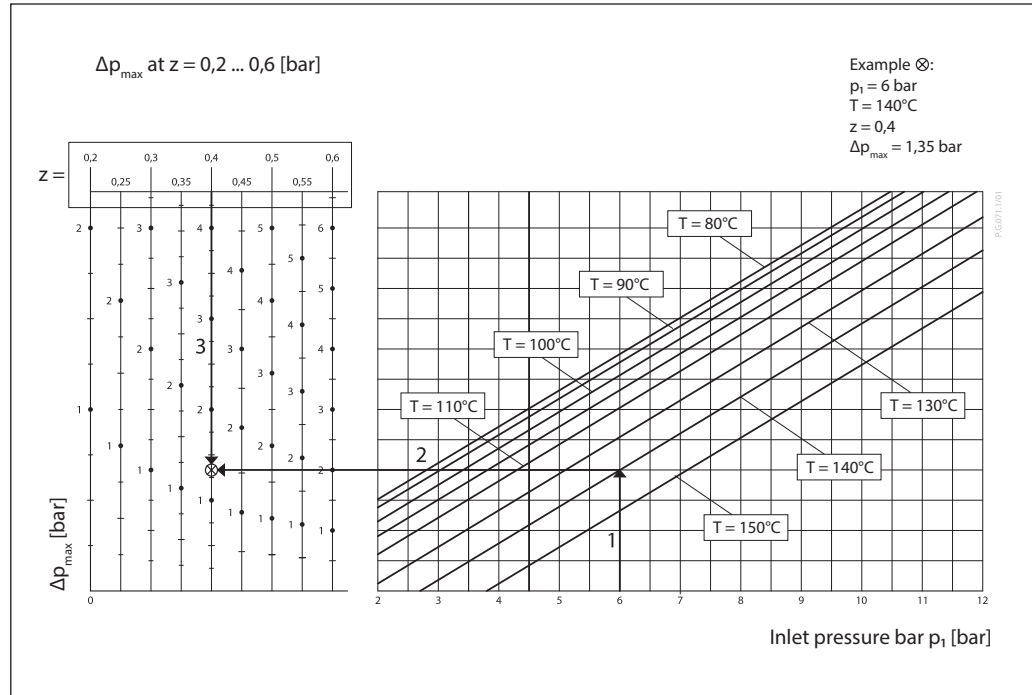

Application principles

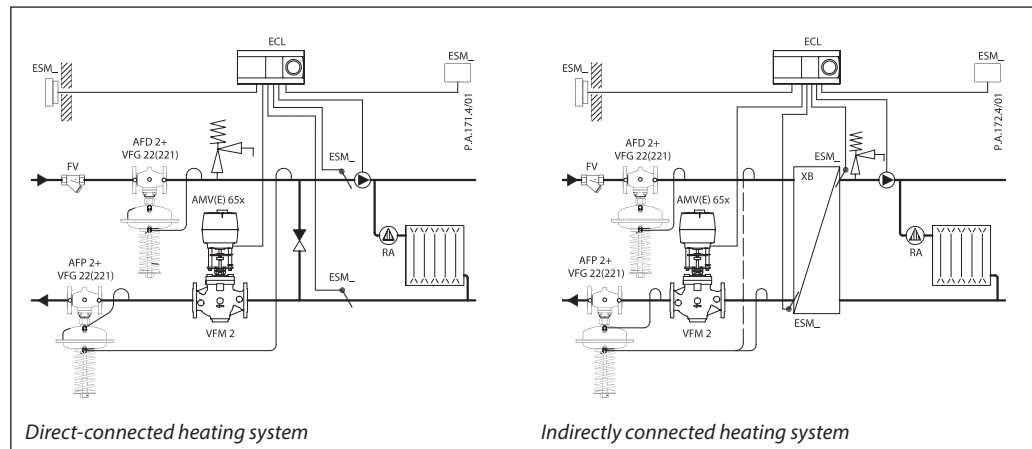

Installation position

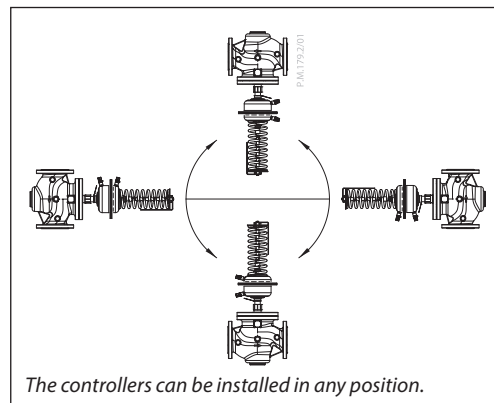

Pressure temperature diagram

Working area is below P-T line and it ends at T_{max} for each valve

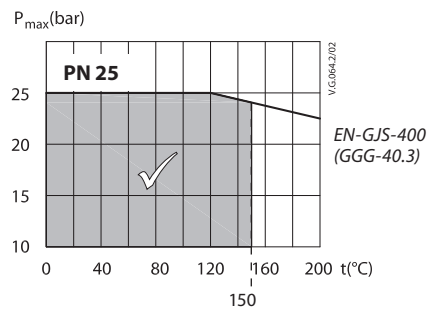
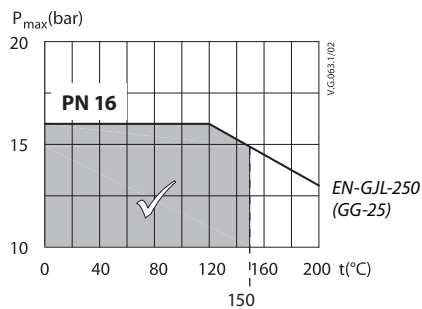

Maximum allowed operating pressure as a function of media temperature (according to EN 1092-2)

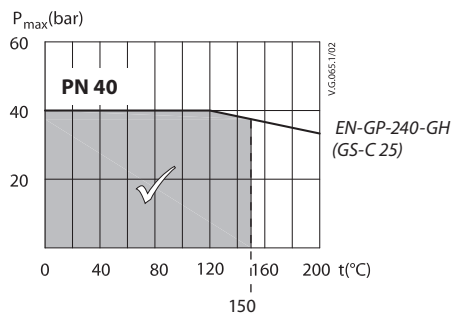

Maximum allowed operating pressure as a function of media temperature (according to EN 1092-1)

Sizing

Pressure reduction controller has to control 6.0 bar behind the controller. Max. flow through the system is less than 4.0 m³/h, min. flow pressure is 7.5 bar.

k_v value is calculated according to formula:

$$k_v = \frac{Q_{\max}}{\sqrt{\Delta p_{AFD}}} = \frac{35}{\sqrt{1.5}}$$

$$k_v = 28.6 \text{ m}^3/\text{h}$$

Given data:

$$Q_{\max} = 35 \text{ m}^3/\text{h}$$

$$p_{1\min} = 7.5 \text{ bar}$$

$$p_{\text{reduced}} = 6.0 \text{ bar}$$

Solution:

AFD 2 3-12

VFG 22(1) DN65 $k_{vS} 60$

Nominal pressure PN 25

The min. differential pressure across the controller is calculated from the formula:

$$\Delta p_{AFD} = p_{1\min} - p_{\text{reduced}} = 7.5 - 6.0$$

$$\Delta p_{AFD} = 1.5 \text{ bar}$$

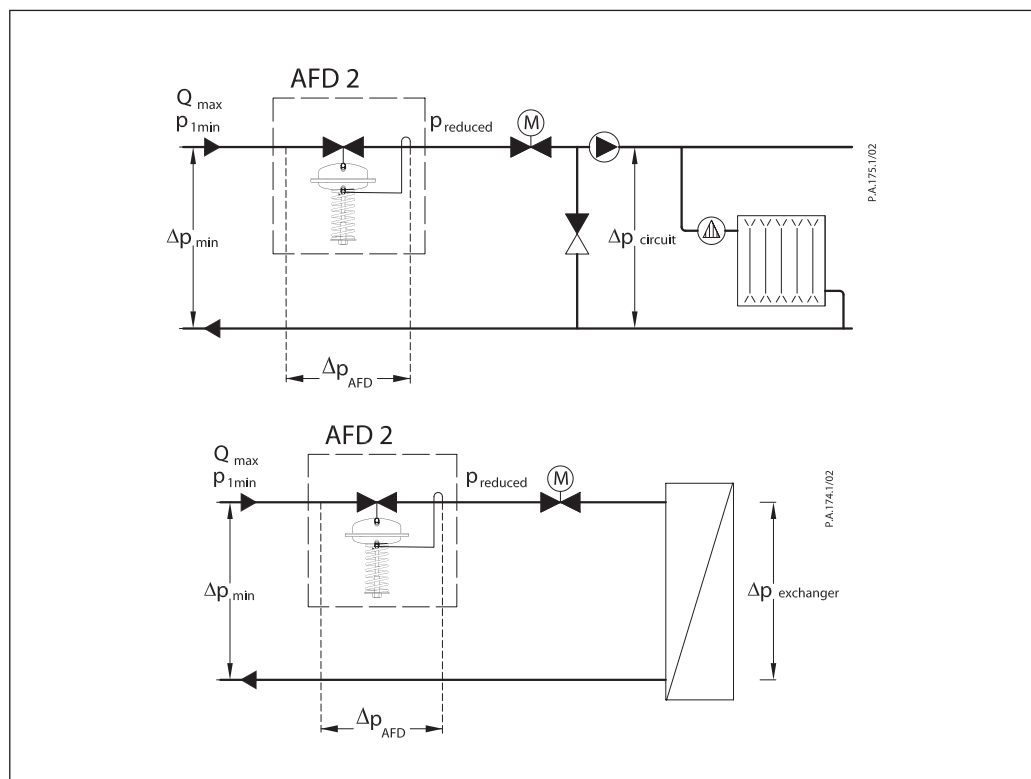

Design

- 1. Valve body
- 2. Valve seat
- 3. Pressure control insert
- 4. Pressure actuator
- 5. Pressure control cone
- 6. Stuffing box
- 7. Cover
- 8. Impulse tube connection
- 9. Diaphragm
- 10. Setting spring for pressure control
- 11. Adjuster for pressure setting
- 12. Setting scale
- 13. Setting indicator
- 14. Union nut
- 15. Air space bore
- 16. Impulse tube

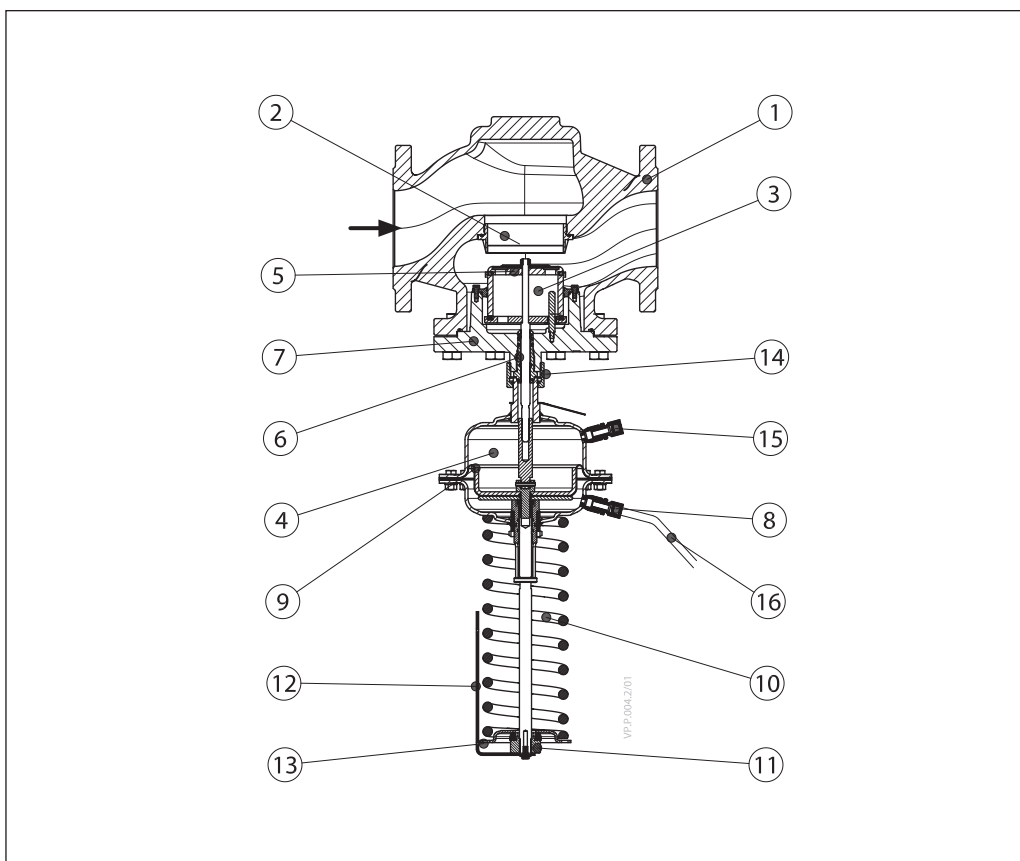

Function

The pressure behind of the control valve is being transferred through the impulse tube to the actuator chamber and act on control diaphragm for pressure control. On the other side of the diaphragm atmospheric pressure is acting (through air space bore). Control valve is normally opened. It closes on rising pressure and opens on falling pressure to maintain constant pressure.

Settings

Pressure setting
 Pressure setting is being done by the adjustment of the setting spring for pressure control. The adjustment can be done by means of spring for pressure setting and pressure indicators.

Dimensions

VFG 22(1) DN 65-250

VFG 22, VFG 221 Valves

DN	L	B	H	H _v	Weight		
					PN 16	PN 25	PN 40
					mm		
					kg		
65	290	245	370	285	24	24	27
80	310	240	365	290	29	29	32
100	350	275	425	350	47	48	53
125	400	270	435	370	60	60	68
150	480	330	520	460	105	106	121
200	600	365	610	550	204	206	235
250	730	420	680	620	343	350	404

AFD 2 Actuator

Size (cm ²)	ØA	H _A	H _{AI}	Weight (kg)		
				AFD 2 PN 16	AFD 2 PN 16 + AMEi 6	AFD 2 PN 40 + AMEi 6
32	175	495	595	10	12.5	17
80	230	510	610	11.5	14	23.5
160	300	510	610	15	17.5	35.5
320	300	630	730	38	40.5	58

Total installation height of the controller (VFG 22(1) valve + AFD 2 pressure actuator) is sum of H_v and H_A (H_{AI})

AMEi 6 intelligent actuator with iNET functionality should be ordered separately

Shut off valve

Compression fitting

Danfoss A/S

Climate Solutions • danfoss.com • +45 7488 2222

All information, including, but not limited to information on selection of product, its application or use, product design, weight, dimensions, capacity or any other technical data in product manuals, catalogues descriptions, advertisements, etc. and whether made available in writing, orally, electronically, online or via download, shall be considered informative, and is only binding if and to the extent, explicit reference is made in a quotation or order confirmation. Danfoss cannot accept any responsibility for possible errors in catalogues, brochures, videos and other material. Danfoss reserves the right to alter its products without notice. This also applies to products ordered but not delivered provided that such alterations can be made without changes to form, fit or function of the product.

All trademarks in this material are property of Danfoss A/S or Danfoss group companies. Danfoss and the Danfoss logo are trademarks of Danfoss A/S. All rights reserved.