



Data sheet

Seated valves (PN 6)

VL 2 – 2-way valve, flange

VL 3 – 3-way valve, flange

Description

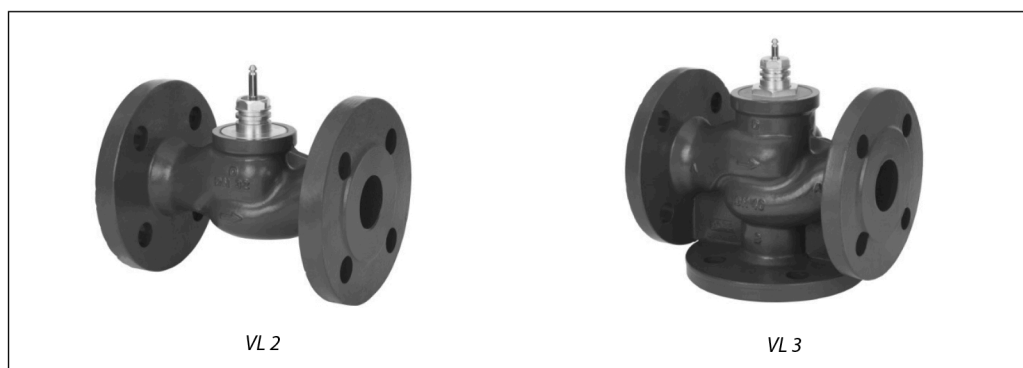

VL 2 and VL 3 valves provide a quality, cost effective solution for most water and chilled applications.

The valves are designed to be combined with following actuators:

- DN 15-50 with AMV(E) 335, AMV(E) 435 or AMV(E) 438 SU actuators. With AMV(E) 25 (SU/SD) or AMV(E) 35 actuators (with adapter **065Z0311**).
- DN 65-80 with AMV(E) 335 or AMV(E) 435 actuators. With AMV(E) 56 actuator (with adapter **065Z0312**).
- DN 100 with AMV(E) 55 or AMV(E) 56, AMV(E) 655, AMV(E) 658 SU/SD or AMV(E) 659 SD actuators.

Combinations with other actuators could be seen under Accessories.

Features:

- Bubble tight design DN 15-80
- Snap mechanical connection together with AMV(E) 335, AMV(E) 435
- Dedicated 2 and 3-port valve
- Suitable for diverting applications (3-port)

Main data:

- DN 15-100
- k_{vs} 0,63-145 m³/h
- PN 6
- Temperature:
 - Circulation water/glycolic water up to 50 %: 2 (-10 ¹⁾) ... 120 °C
 - ¹⁾ At temperatures from -10 °C up to +2 °C use stem heater
- Flange PN 6 connections

Ordering

Example:
2-way valve; DN 15; k_{vs} 1,6; PN 6;
 T_{max} 120 °C; flange connection

- 1x VL 2 DN 15 valve
Code No.: **065Z0373**

2-way valve **VL 2**

DN	k_{vs} (m ³ /h)	T_{max} (°C)	Code No.
15	0.63	120	065Z0371
	1.0		065Z0372
	1.6		065Z0373
	2.5		065Z0374
	4.0		065Z0375
20	6.3		065Z0376
25	10		065Z0377
32	16		065Z0378
40	25		065Z0379
50	40		065Z0380
65	63	065Z0381	
80	100	065Z0382	
100	145	065Z3426	

3-way valve **VL 3**

DN	k_{vs} (m ³ /h)	T_{max} (°C)	Code No.
15	0.63	120	065Z0351
	1.0		065Z0352
	1.6		065Z0353
	2.5		065Z0354
	4.0		065Z0355
20	6.3		065Z0356
25	10		065Z0357
32	16		065Z0358
40	25		065Z0359
50	40		065Z0360
65	63	065Z0361	
80	100	065Z0362	
100	145	065Z3413	

Ordering (continued)
Accessories - Adapter

DN	Actuators	max. Δp (bar)	Code No.
15-50	AMV(E) 25, 35	4.0	065Z0311
65-80	AMV(E) 56	2.5	065Z0312

Accessories - Stem heater

DN	Actuators	Power supply (V/VA)	Code No. Stem Heater	Code No. Adapter
15-80	AMV(E) 335, 435	24/40	065Z0315	/
15-50	AMV(E) 438 SU			enclosed
15-50	AMV(E) 25/35			065Z0311
65-80	AMV(E) 56			065Z0312
100	AMV(E) 55, 56, 65x	24/15	065Z7020	/

Service kits

Type	DN	Code No.
Stuffing box	15	065Z0321
	20	065Z0322
	25	065Z0323
	32	065Z0324
	40/50	065Z0325
	65/80	065Z0327
	100	065B1360

Technical data

Nominal diameter	DN	15		20	25	32	40	50	65	80	100			
k_{vs} value	m ³ /h	0.63	1.0	1.6	2.5	4.0	6.3	10	16	25	40	63	100	145
Stroke	mm	10					15			20		30		
Control range		30:1	50:1			100:1								
Control characteristic		LOG: port A-AB; LIN: port B-AB												
Cavitation factor z		$\geq 0,4$												
Leakage		A - AB bubble tight design										0.05 % of k_{vs}		
		B - AB ≤ 1.0 % of k_{vs}												
Nominal pressure	PN	6												
Max. closing pressure ¹⁾ (mixing)	bar	4								2.5		1.0 ²⁾		
Max. closing pressure ¹⁾ (diverting)		1								0.6		0.3 ²⁾		
Medium		Circulation water / glycolic water up to 50 %												
Medium pH		Min. 7, Max. 10												
Medium temperature	°C	2(-10 ³⁾ ... 120												
Connections		Flange PN 6 acc. to EN 1092-2												
Materials														
Valve body		Grey cast iron EN-GJL-250 (GG-25)												
Valve stem		Stainless steel												
Valve cone		Brass ⁴⁾												
Stuffing box sealing		EPDM												

¹⁾ Maximum permissible differential pressure across the valve referred for the whole actuating range of motorised valve (a function of actuator's performance)

²⁾ for actuator AMV(E) 55

³⁾ At temperatures from -10 up to +2 °C use stem heater

⁴⁾ At DN 100 red bronze CuSn5Zn5Pb5 (Rg 5)

Pressure temperature diagram

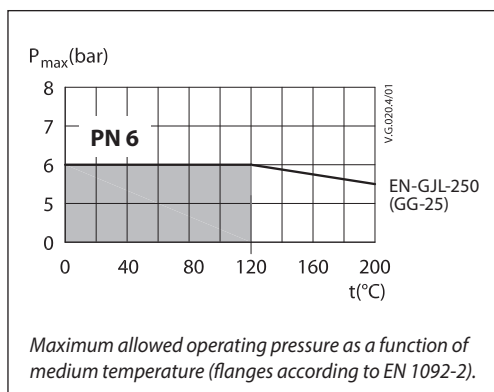

Valve characteristics

Valve characteristics log (2-way)

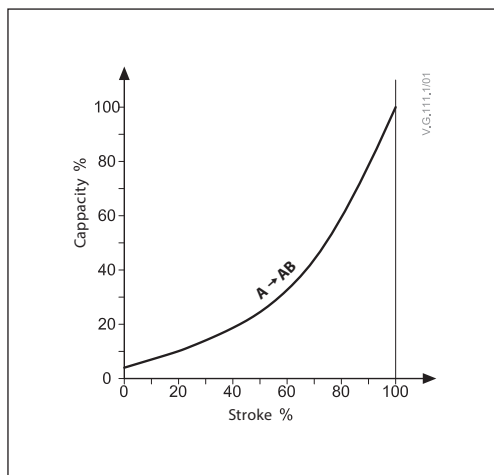

Valve characteristics log/lin (3-way)

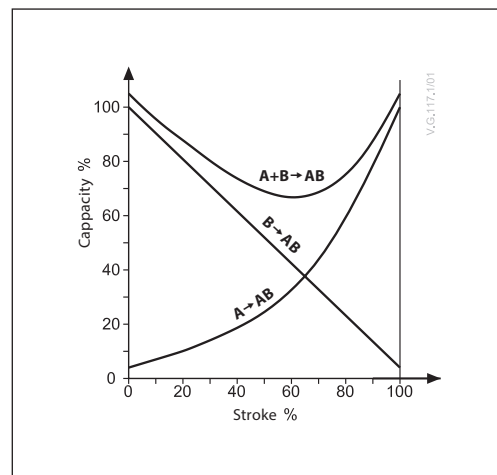

Installation

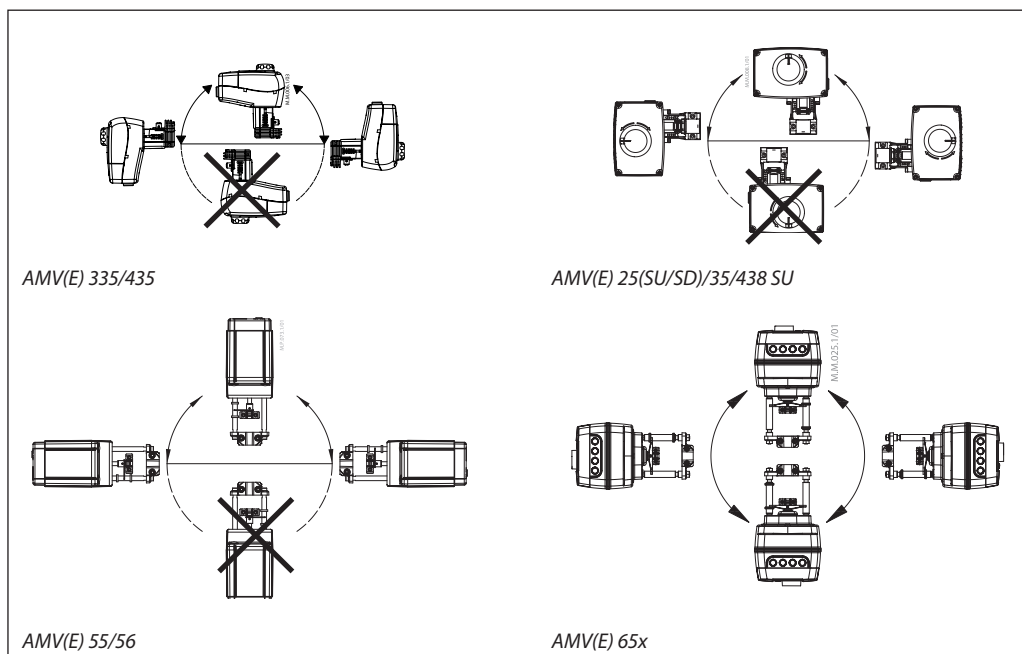

Valve mounting

Before valve mounting the pipes have to be cleaned and free from abrasion. Valve must be mounted according to flow direction as indicated on valve body. Mechanical loads of the valve body caused by the pipes are not allowed. Valve should be free of vibrations as well.

Installation of the valve with the actuator is allowed in horizontal position or upwards. Installation downwards is not allowed.

Always install the valve with the arrow on the body in the same direction as the flow. In order to avoid turbulence, which will affect the measuring accuracy, it is recommended to have a straight length of pipe up and down stream from the valve as shown (D - diameter of pipe).

Note:

Install a strainer upstream of the valve (e.g. Danfoss FVR/ FVF)

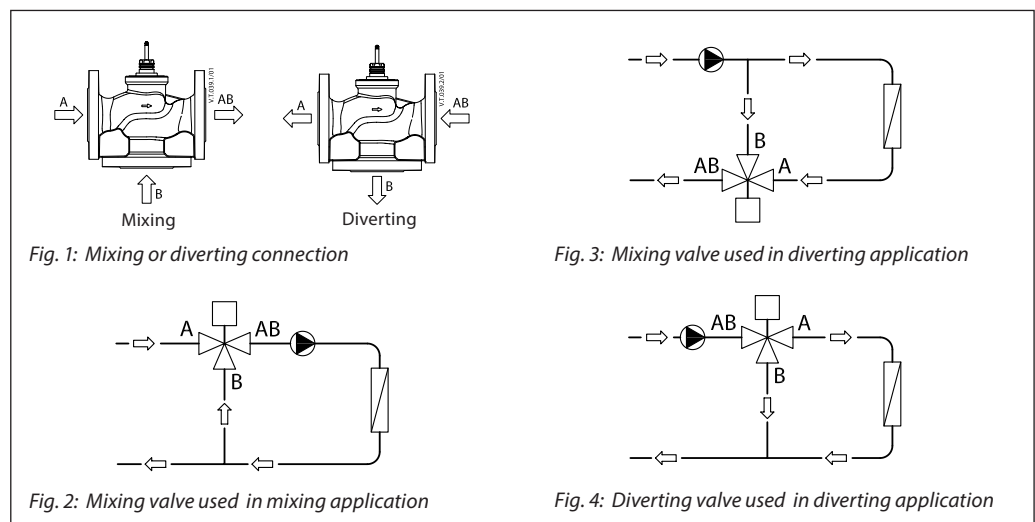
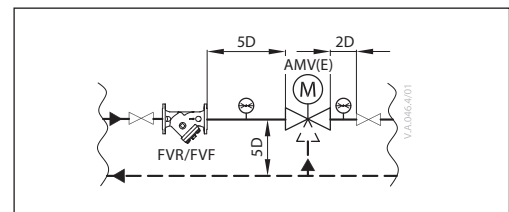

Fig. 1: Mixing or diverting connection

Fig. 3: Mixing valve used in diverting application

Fig. 2: Mixing valve used in mixing application

Fig. 4: Diverting valve used in diverting application

Mixing or diverting connection

3-way valve can be used either as mixing or diverting valve (fig.1).

If 3-way valve is installed as mixing valve meaning that A and B ports are inlet ports, and AB port is outlet port it can be installed in mixing (fig.2) or diverting application (fig.3).

3-way valve can be also installed as diverting valve in diverting application (fig.4) meaning that AB port is inlet and A and B ports are outlets.

Note:

Maximal closing pressure for mixing and diverting installation are not the same. Please refer to values stated in Technical data section.

Sizing

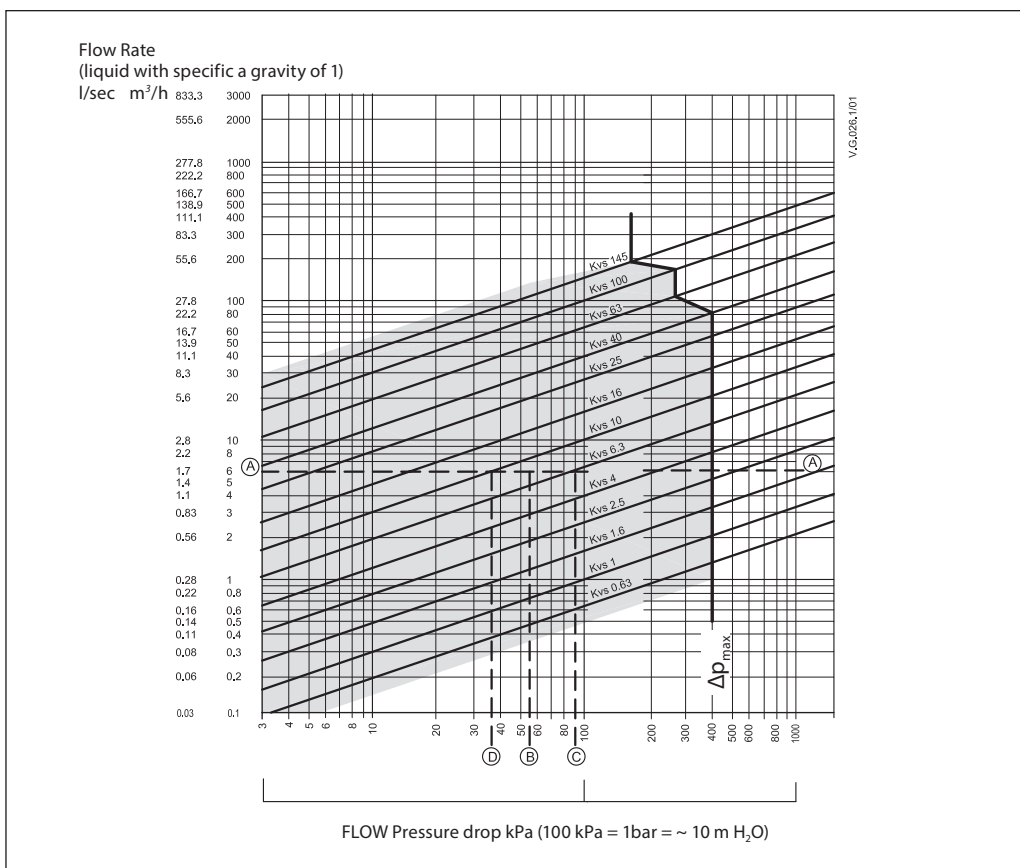

Example

Design data:
 Flow rate: 6 m³/h
 System pressure drop: 55 kPa

Locate the horizontal line representing a flow rate of 6 m³/h (line A-A). The valve authority is given by the equation:

$$\text{Valve authority, } a = \frac{\Delta p_1}{\Delta p_1 + \Delta p_2}$$

Where:

Δp_1 = pressure drop across the fully open valve
 Δp_2 = pressure drop across the rest of the circuit with a full open valve

The ideal valve would give a pressure drop equal to the system pressure drop (i.e. an authority of 0,5):

if:

$$\Delta p_1 = \Delta p_2$$

$$a = \frac{\Delta p_1}{2 \times \Delta p_2} = 0.5$$

In this example an authority of 0,5 would be given by a valve having a pressure drop of 55 kPa at that flow rate (point B). The intersection of line A-A with a vertical line drawn from B lies between two diagonal lines; this means that no ideally-sized valve is available.

The intersection of line A-A with the diagonal lines gives the pressure drops stated by real, rather than ideal, valves. In this case, a valve with k_{vs} 6,3 would give a pressure drop of 90,7 kPa (point C):

$$\text{hence valve authority} = \frac{90.7}{90.7 + 55} = 0.62$$

The second largest valve, with k_{vs} 10, would give a pressure drop of 36 kPa (point D):

$$\text{hence valve authority} = \frac{36}{36 + 55} = 0.395$$

Generally, for a 3 port application, the smaller valve would be selected (resulting in a valve authority higher than 0,5 and therefore improved control). However, this will increase the total pressure and should be checked by the system designer for compatibility with available pump heads, etc. The ideal authority is 0,5 with a preferred range of between 0,4 and 0,7.

Design

(Design variations are possible)

VL 2 DN 15-80

- 1. Valve body
- 2. Valve insert
- 3. Valve cone
- 4. Valve stem
- 5. Moving valve seat (pressure relieved)
- 6. Stuffing box

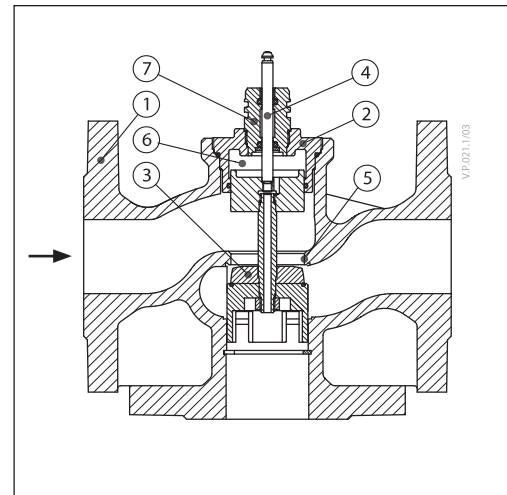
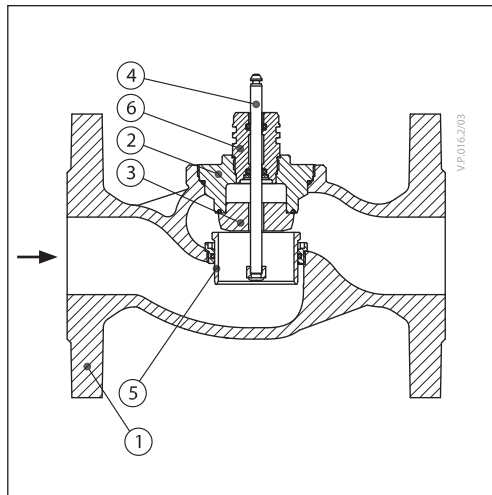

VL 3 DN 15-80

- 1. Valve body
- 2. Valve insert
- 3. Valve cone
- 4. Valve stem
- 5. Valve seat
- 6. Pressure relieve chamber
- 7. Stuffing box

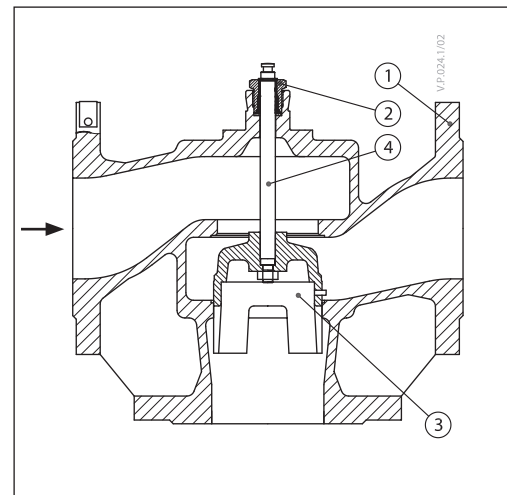
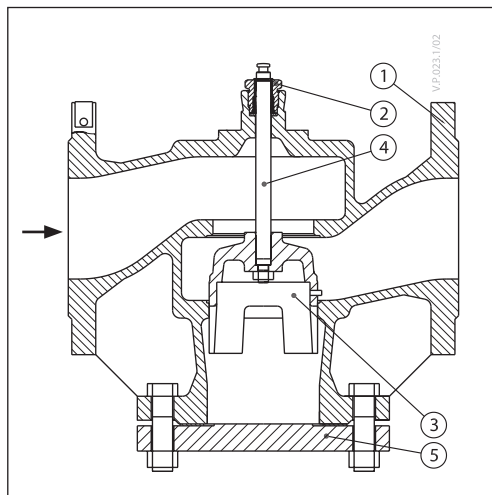

VL 2 DN 100

- 1. Valve body
- 2. Valve insert
- 3. Valve cone
- 4. Valve stem
- 8. Blind flange

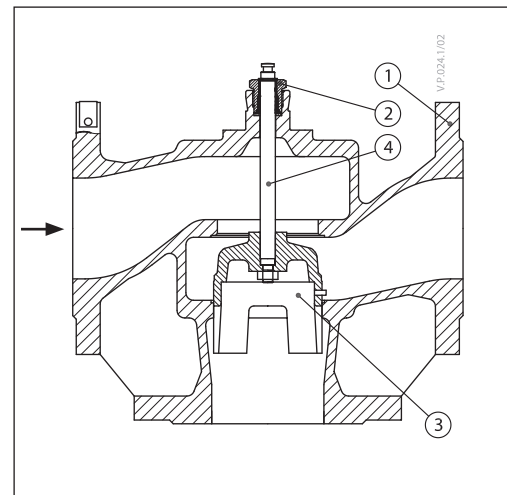
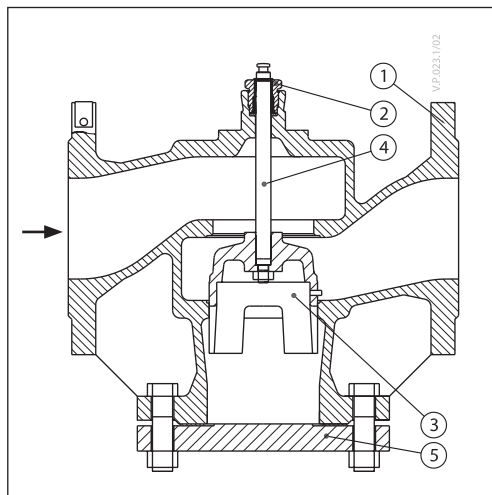

VL 3 DN 100

- 1. Valve body
- 2. Valve insert
- 3. Valve cone
- 4. Valve stem

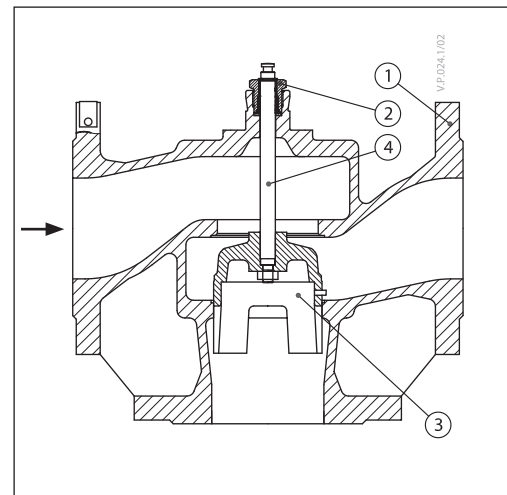
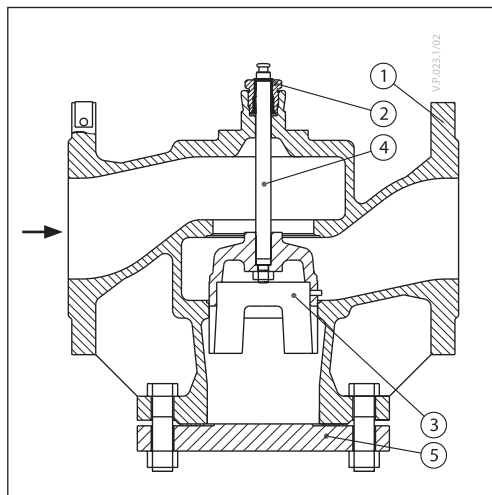

Dimensions

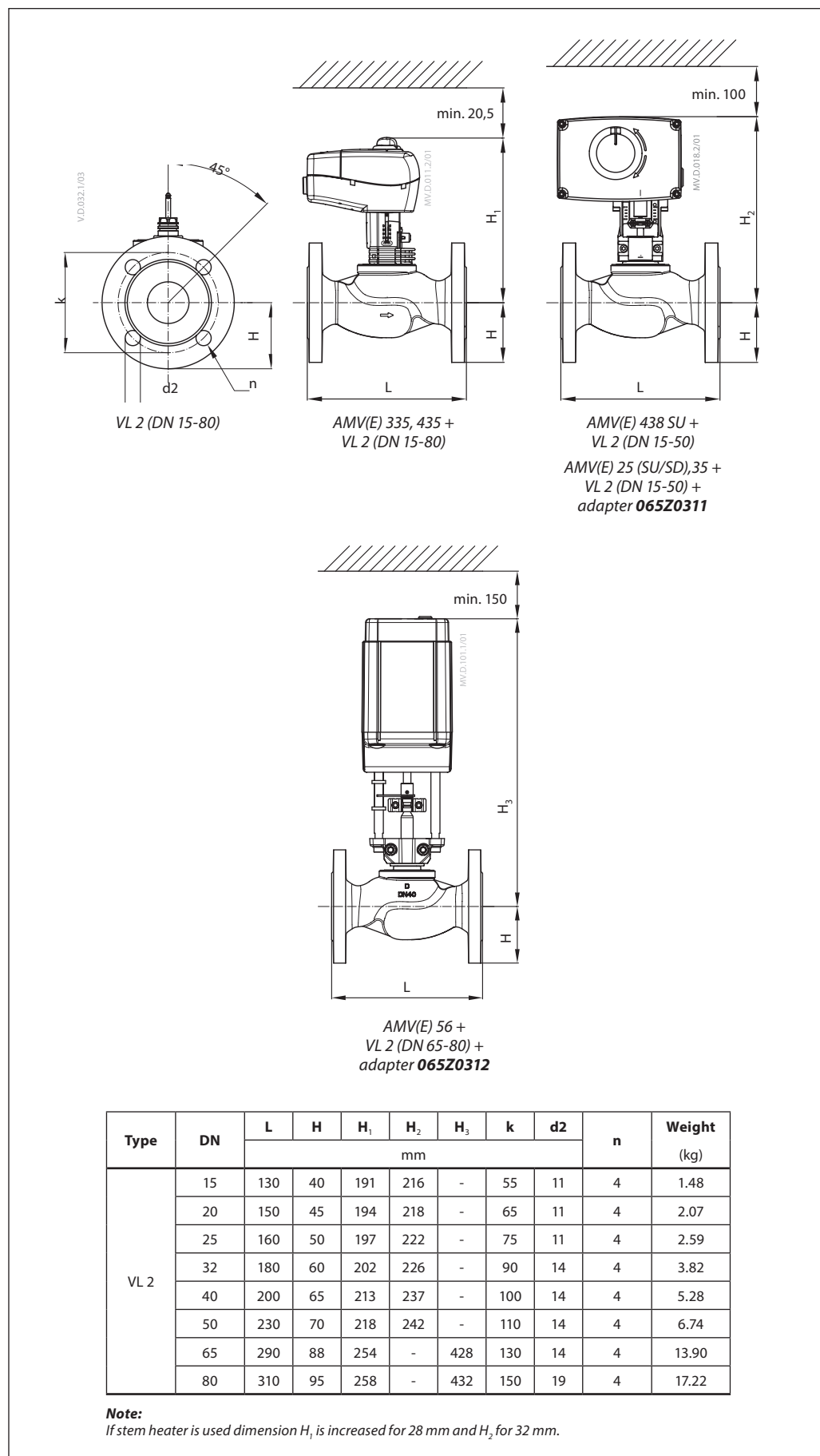

Dimensions (continued)

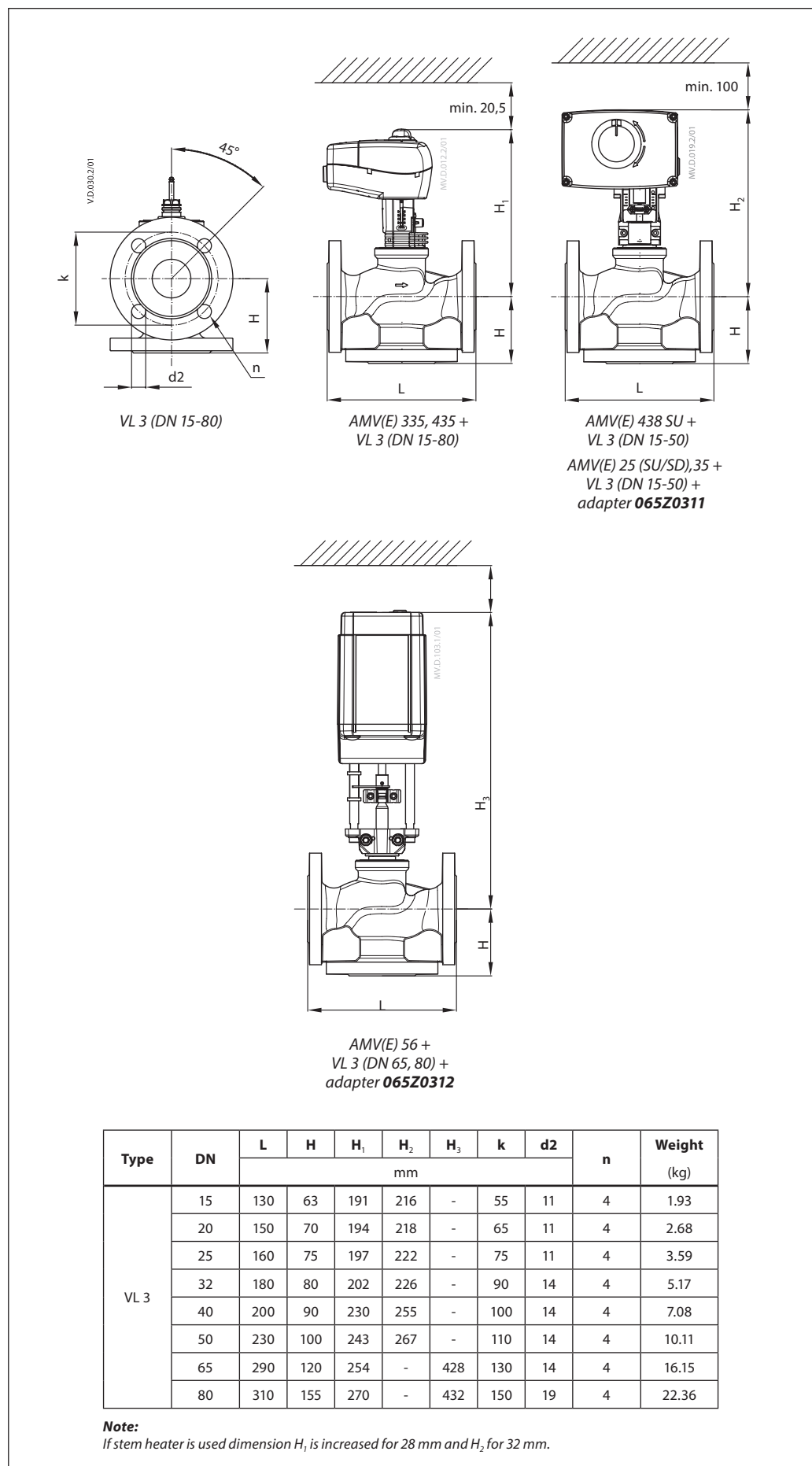

Dimensions (continued)

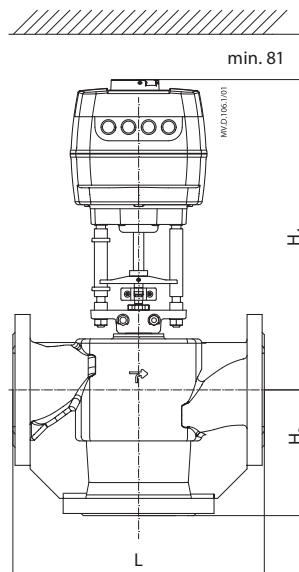
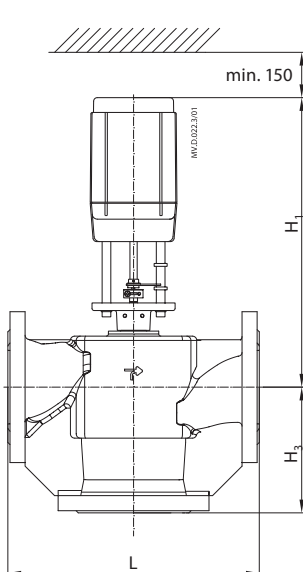
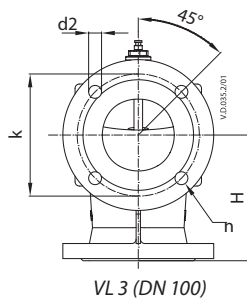
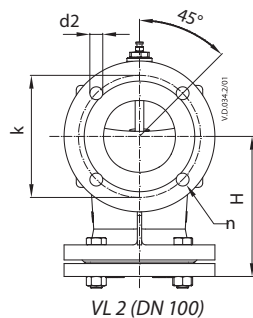

Type	DN	L	H	H1	H2	H3	k	d2	n	Weight (kg)
VL 2	100	350	196	406	317	450	170	18	4	39.0
VL 3			175							34.0

Note:
If stem heater is used dimension H remains the same.



Danfoss A/S

Climate Solutions • climatesolutions.danfoss.com • +45 7488 2222 • E-Mail: climatesolutions@danfoss.com

Any information, including, but not limited to information on selection of product, its application or use, product design, weight, dimensions, capacity or any other technical data in product manuals, catalogues descriptions, advertisements, etc. and whether made available in writing, orally, electronically, online or via download, shall be considered informative, and is only binding if and to the extent, explicit reference is made in a quotation or order confirmation. Danfoss cannot accept any responsibility for possible errors in catalogues, brochures, videos and other material. Danfoss reserves the right to alter its products without notice. This also applies to products ordered but not delivered provided that such alterations can be made without changes to form, fit or function of the product.

All trademarks in this material are property of Danfoss A/S or Danfoss group companies. Danfoss and the Danfoss logo are trademarks of Danfoss A/S. All rights reserved.