

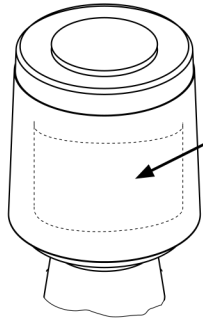

Operating Guide

TWA-Z (Gen. 2011)



24 V
230 V
NO
NC

Class III transformer (SELV)
Max. 3 A pre-fuse
Normally Open
Normally Closed

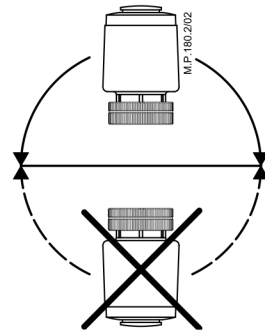
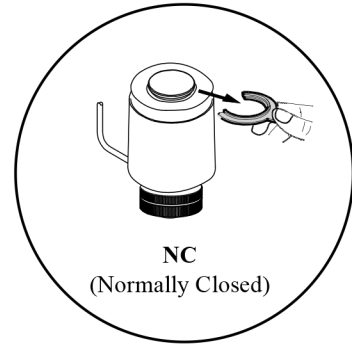

IP 41

TWA-Z & AB-QM

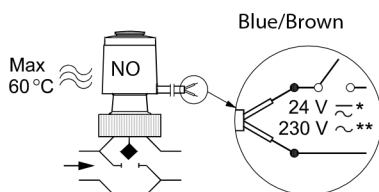
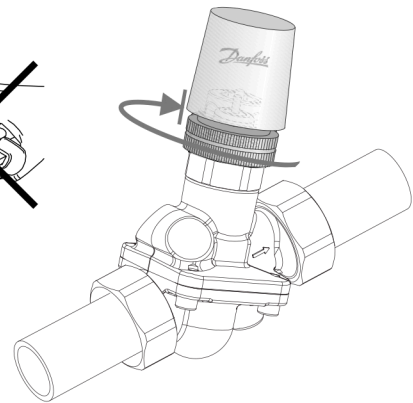
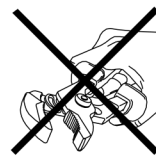
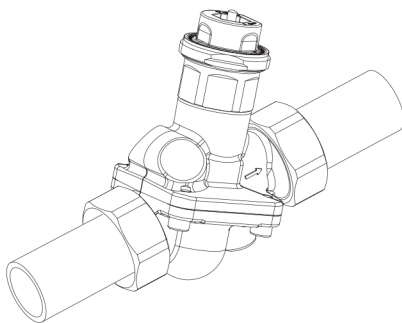

TWA-Z NO & AB-QM

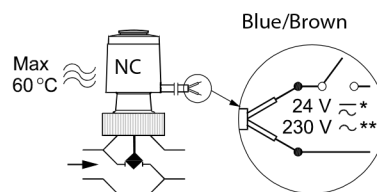

TWA-Z NC & AB-QM

TWA-Z

TWA-Z (Gen. 2011) & AB-QM (2nd gen.)

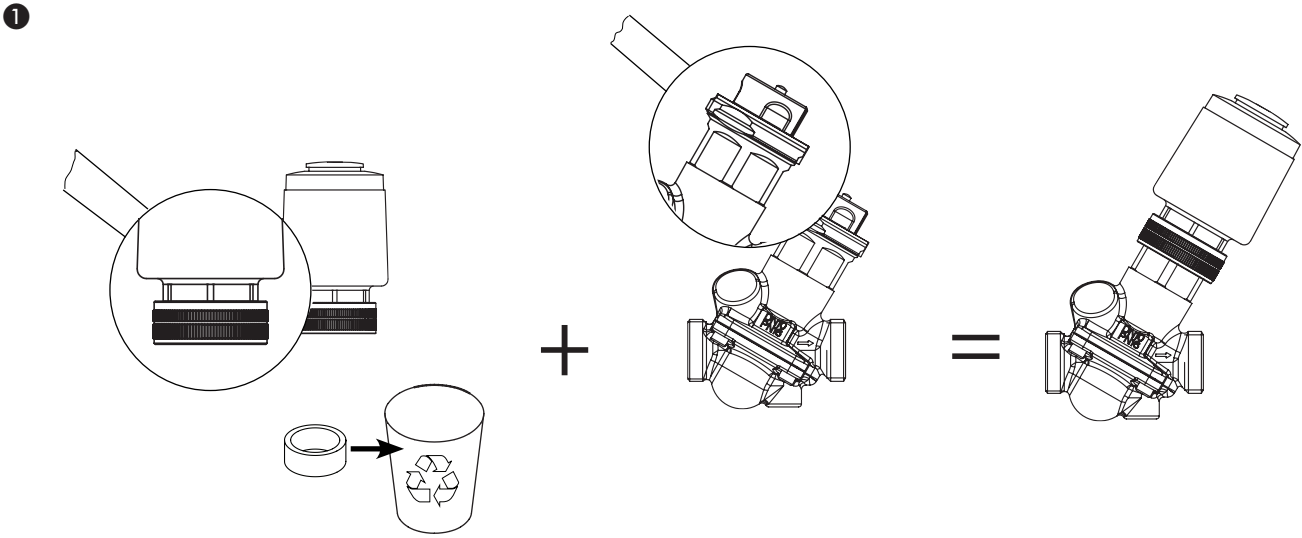

TWA-Z (Gen. 2011) & AB-QM (1st gen.)

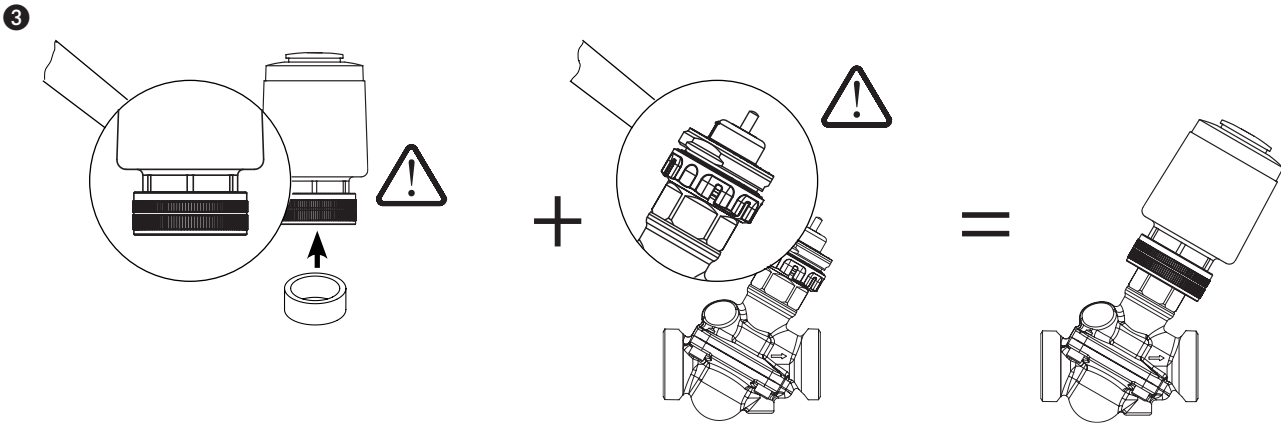

Part Name 部件名称	Hazardous Substances Table/有害物质含量表					
	Pb/铅	Hg/汞	Cd/镉	Cr(VI)/六价铬	PBB/多溴联苯	PBDE/多溴二苯醚
Wax element / 石蜡恒温元件	X	O	O	O	O	O
O: Indicates that this hazardous substance contained in all of the homogeneous material for this part is below the limit requirement in GB/T 26572; O: 表示该有害物质在该部件所有均质材料中的含量均在GB/T 26572规定的限量要求以下。						
X: Indicates that this hazardous substance contained in at least one of the homogeneous material for this part is above the limit requirementw in GB/T 26572; X: 表示该有害物质至少在该部件的某一均质材料中的含量超出GB/T 26572规定的限量要求。						

Danfoss A/S
 Heating Segment • heating.danfoss.com • +45 7488 2222 • E-Mail: heating@danfoss.com

Danfoss can accept no responsibility for possible errors in catalogues, brochures and other printed material. Danfoss reserves the right to alter its products without notice. This also applies to products already on order provided that such alterations can be made without subsequent changes being necessary in specifications already agreed. All trademarks in this material are property of the respective companies. Danfoss and all Danfoss logotypes are trademarks of Danfoss A/S. All rights reserved.