



Data sheet

Actuator ABNM A5 LOG/LIN

Description



The ABNM A5 0-10V thermal actuator has been specifically designed for use with AB-QM valves DN10-32/1/2-1 3/4 inch in heating and cooling applications.

Actuator convincing features are:

- Stroke 5.0 mm or 6.5 mm
- Detection of AB-QM opening and closing point
- Available as normally closed (NC) or normally open (NO)

- Power consumption 1/1.2 W
- Plug-in halogen free cable
- Simple snap-on installation
- IP54 in any installation position
- First-Open function (NC versions)
- Compact size, small dimensions
- LIN and LOG versions
- 24V AC and DC versions
- All round function indicator
- Noiseless and maintenance-free
- Certified by TÜV

Control is done by a 0-10 V signal, which is provided either by a room thermostat or, in most cases, by a central direct digital control (DDC) system. The actuator converts the 0-10 V signal into a proportional actuator travel, which can be either linear (ABNM A5 LIN) or logarithmic/equal percentage (ABNM A5 LOG). For fan coil unit or chilled ceiling application choice of logarithmic version is recommended (water to air heat exchanger). The result will be linear system response and thus optimal room temperature control.

Ordering

Type	Supply voltage	Stroke	Normally Open/ Normally Closed	LOG/LIN	Code No.
ABNM A5, with VA41 adapter, without cable	24 V AC	5 mm	NC	LOG	082F1160
			NC	LIN	082F1161
		6.5 mm	NC	LOG	082F1162
			NO	LOG	082F1163
	NC		LIN	082F1164	
	NO		LIN	082F1165	
	24 V DC	NC	LOG	082F1166	
		NO	LOG	082F1167	

Accessories

Adapter VA41 for AB-QM is included with actuator. In case you wish to use ABNM A5 actuator with RA valves, order adapter VA78 separately.

Adapter	Code No.
VA78	082F1071

Cables are not included and should be ordered separately. All cables are made from halogen free material.

Cables	Code No.
1 meter	082F1081
5 metres	082F1082
10 metres	082F1083

Function

The actuator mechanism of the ABNM actuator uses a positive temperature coefficient (PTC) resistor heated wax element and a compression spring.

The wax element is heated by applying the operating voltage and moves the integrated piston. The force generated by this movement is transferred to valve spindle and thus opening or closing the valve. The actuator provides active regulation in a defined range (see characteristic curve between 0.5 V and 9.5 V).

The function display (all-round display) of the ABNM shows at the first glance whether the valve is "open" or "closed".

First open function (for NC versions only)

In its delivery condition ABNM is partly open due to the first open function (filling). This enables heating/cooling operation during the carcass construction phase even when the electric wiring is not yet complete. During the later electrical start-up, the first open function is unlocked by applying the power supply for more than 6 minutes.

Version NC "normally closed"

In case of the normally closed version, valve is closed when de-energized. Valve is opened steadily upon switching on the power supply, setting control signal to 10 V and after expiry of the dead time.

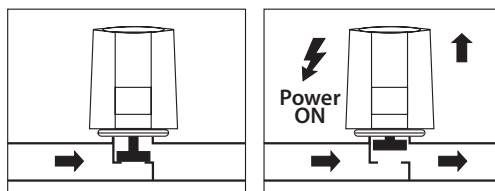

Function display for NC versions extends proportionally with actuator opening from 0 mm to 5-6 mm.

Version NO "normally open"

In case of the normally open version, valve is open when de-energized. Valve is closed steadily upon switching on the power supply, setting control signal to 0 V and after expiry of the dead time.

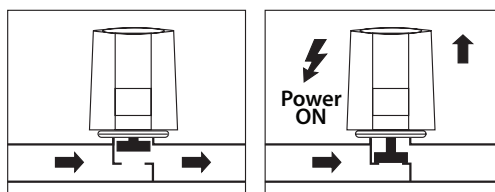

Function display for NO versions extends only when valve is fully closed by approx. 0.5 mm.

Automatic initial calibration (for NC and NO versions)

Automatic initial calibration is done at the first power on of the actuator (new actuator). If the actuator is switched off within 8 hours after the calibration is performed, each restart of the actuator begins with a new initial calibration, which last about 30 minutes. The power supply needs to be applied for 30 min. (± 10 min.) in order to finalize the calibration phase, which includes valve opening and closing point detection. This ensures an optimum match with the AB-QM valve used at any preset between 20% and 100%. Active control range is thus between 0.5 V and 9.5 V what ensures precise flow and temperature control.

Automatic initial calibration stores calibration parameters in the actuators non-volatile memory after 8 hours. The information remains in the actuators memory, also if actuator actuator power supply is disconnected.

Manual re-calibration (for NC and NO versions)

In case you change valve type or valve preset after initial calibration is finished, apply 0 V control voltage for 60 min. for closing point detection and 10 V control voltage for 60 min. for new opening point detection.

Please note the actuator stores this information in non-volatile memory 8 hours after re-calibration. If power is lost within 8 hours after re-calibration, then this information is lost, and you need to repeat the re-calibration procedure.

Automatic re-calibration (for NC and NO versions)

In case you change valve type or valve preset after initial calibration is finished and exact timing of re-calibration is not important, manual re-calibration procedure can be avoided. Controller will during normal course of operation sooner or later give control signal 0 V and 10 V. Actuator will automatically detect new closing point when control signal is 0 V for 60 min. and new opening point when control signal is 10 V for 60 min. We cannot guarantee duration of this procedure, as it depends from control signal from controller.

Operation after power-off

If power is lost within 8 hours after 8 calibration, then you need to repeat re-calibration procedure.

Data

ABNM A5 type	5 mm versions AC	6.5 mm versions AC	6.5 mm versions DC
Versions	NC, LOG/LIN	NC/NO, LOG/LIN	NC/NO, LOG
Voltage	24 V AC 50/60 Hz (-10 % to +20 %)	24 V AC 50/60 Hz (-10 % to +20 %)	24 V DC (-20 % to +20 %)
Max. inrush current	< 300 mA for max. 2 min.	< 300 mA for max. 2 min.	< 300 mA for max. 2 min.
Operating power	1 W ¹⁾	1.2 W ¹⁾	1.2 W ¹⁾
Control voltage	0-10 V DC	0-10 V DC	0-10 V DC
Input resistance	100 kΩ	100 kΩ	100 kΩ
Actuator travel	5 mm (- 0.5 mm overclosing)	6.5 mm (- 0.5 mm overclosing)	6.5 mm (- 0.5 mm overclosing)
Actuating force	100 N + 10 %	125 N ± 5 %	125 N ± 5 %
Closing (NC) or opening (NO) time when de-energized	3-5 min.	3-5 min.	3-5 min.
Speed	30 s/mm ²⁾	30 s/mm ²⁾	30 s/mm ²⁾
Calibration time (including First Open for NC)	30 ± 10 min. ²⁾	30 ± 10 min. ²⁾	30 ± 10 min. ²⁾
Delay when energized (heat up time)	2-3 min.	2-3 min.	2-3 min.
Fluid temperature	0 - 100 °C ²⁾	0 - 100 °C ²⁾	0 - 100 °C ²⁾
Storage temperature	-25 to 65 °C	-25 to 65 °C	-25 to 65 °C
Ambient temperature	0 to 60 °C	0 to 60 °C	0 to 60 °C
Ambient humidity	95 % r.h., non-condensing		
Degree/class of protection	IP54 ³⁾ /III safety extra-low voltage	IP54 ³⁾ /III safety extra-low voltage	IP54 ³⁾ /III safety extra-low voltage
CE conformity according to	EN60730	EN60730	EN60730
UL certification	UL60730	UL60730	UL60730
Connecting cable (no included)	3 x 0.22 mm ² halogen free	3 x 0.22 mm ² halogen free	3 x 0.22 mm ² halogen free
Adapter (included)	VA 41	VA 41	VA 41
Overvoltage resistance EN60730-1	min. 1 kV	min. 1 kV	min. 1 kV
Weight	111 g	111 g	111 g
Housing material	Polyamid / white	Polyamid / white	Polyamid / white

¹⁾ Measured with precision power meter LMG95.

²⁾ Measured at ambient temperature 20°C. Due to thermal working principle of actuator some parameters vary with ambient temperature. At higher ambient temperatures actuator opening is faster and closing slower. At lower ambient temperatures actuator closing will be faster and opening slower.

³⁾ In all installation positions with cable plugged in.

Characteristic Curves

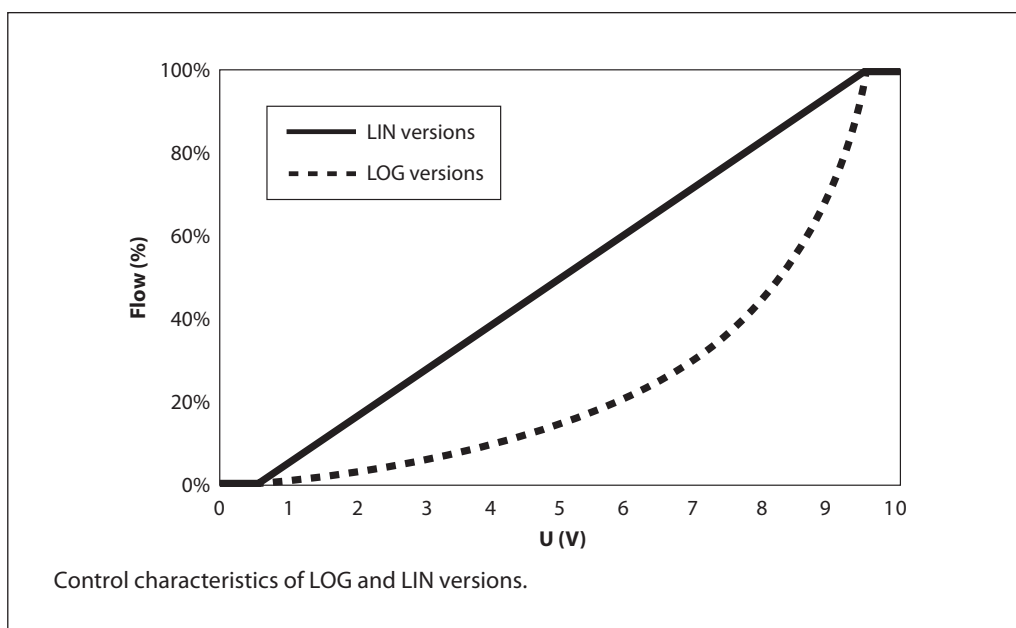

Electrical Connections

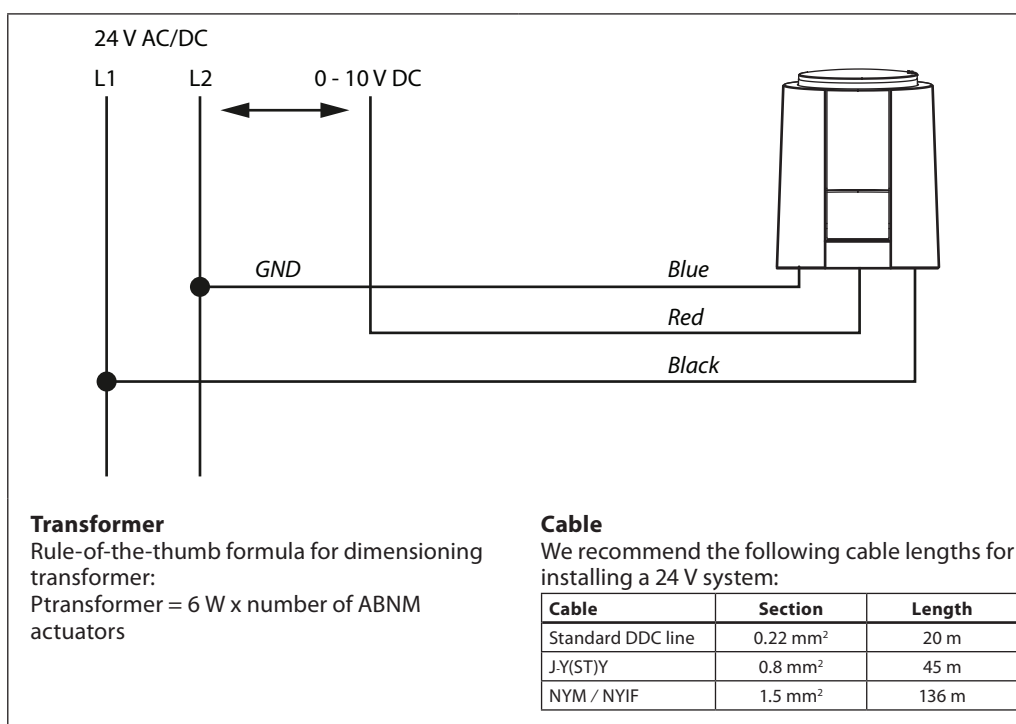

Installation

1 Danfoss AB-QM VA41

2

3

4

Click

IP54 in any position with cable plugged in

Screw the valve adapter manually onto the valve and connect cable and actuator.

Place the actuator vertically on the valve adapter. The actuator snaps onto the valve adapter with a "click" when pressed down vertically by hand. Do not apply power until the actuator is mounted on the valve.

First Open Function

~2mm

~7mm

~0.5mm

Power on >6min

Power on >3min

Presentation of First Open Function (Unlock NC version).

Calibration

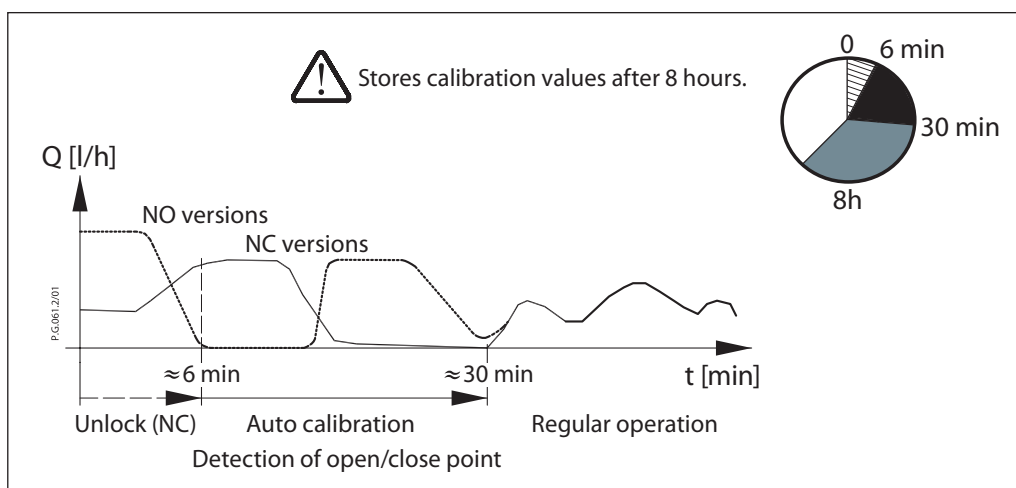

Automatic initial calibration procedure to actual preset AB-QM stroke (detection of opening and closing point). ABNM A5 actuator needs ~30 min. for first calibration (including First Open Function (NC versions only) and valve open and close point detection. In case of power loss the actuator will remember its position and will not need recalibration if the first calibration was finished. If the valve pre-set is changed after the first calibration is finished, the actuator will automatically detect the new open and close

point during normal operation. In order to accelerate this process cycle voltage to 0 V for 60 min. and 10 V for 60 min. In case of power loss within 8 hours after calibration the actuator will lose its calibration parameters and initialize a new calibration when restarted. In case of power loss after 8 hours after re-calibration the actuator will remember its position and will not need recalibration.

Dimensions

