

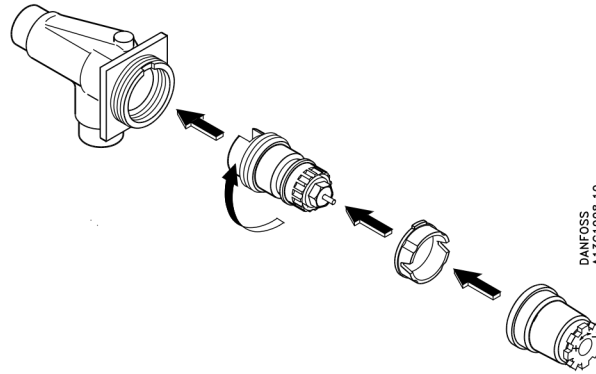

Data Sheet

Integrated Presetting Valve, Type RA-N 013G3259 - with Soldering Connection

Application



The valve is specially intended and designed to be built in the radiator by the radiator manufacturer.

The valve is supplied unassembled in five main groups: valve body, valve top assembly, valve insert, protective cap, and rotation lock.

The valve body RA-N is used in two-pipe district or central heating systems with pump, or in one-pipe pumped systems.

The valve body is made of MS 58 brass.

RA-N is fitted with built-in presetting of max. water flow within the setting range:
 $k_v = 0.16 - 1.00 \text{ m}^3/\text{h}$

In order to avoid deposition and corrosion, the composition of the hot water must be in accordance with the VDI 2035 guideline (Verein Deutscher Ingenieure).

Danfoss thermostatic sensors type RA 2000 and RAW with patented snap sockets as well as Danfoss thermo-hydraulic actuators can be installed directly onto the integrated valve.

Code Nos. and Technical Data

Type	Solder connection		Presetting									Max. water temp. °C	Code no.
	In, Ø mm	Out, Ø mm	k_v -value ^{2) 3)}								k_{vs}		
			1	2	3	4	5	6	7	N		N	
RA-N, angle ¹⁾	15	15	0.16	0.20	0.25	0.35	0.47	0.60	0.73	0.80	1.00	120	013G3259

Pressure data: Differential pressure ⁴⁾: 0.6 bar, max. working pressure: 10 bar, test pressure: 16 bar.

¹⁾ Inlet and outlet socket prepared for soldering of pipes.

²⁾ The k_v -values indicate the flow volume (Q) in m^3/h at a pressure loss (Δp) across the valve of 1 bar;

$k_v = \frac{Q}{\sqrt{\Delta p}}$. At setting N, the k_v -value in accordance with EN 215 can be stated as $X_p = 2 \text{ K}$. At lower preset values, X_p will be reduced until approximately $X_p 0.5$ at presetting 1. The table shows the average measured values for integrated valves with radiator. The k_{vs} -values indicate the valve capacity, when the valve is fully open.

- 3) When using a liquid filled radiator thermostat e.g. RAW, RAS-D or remote setting element type RA 5060 X_p will be increased by factor 1.6 (at setting "N", ref. EN 215).
- 4) The technical differential pressure indicates the upper limit for a proper valve function. In most two-pipe systems the recommended differential pressure is sufficient. In order to achieve a noiseless function we recommend in smaller systems to apply automatic bypass valves or automatic balancing valves. If pump differential pressure exceeds the recommended max. valve differential pressure it is recommended that an automatic balancing valve type ASV-P/PV is added to the system.

Spare Parts and Accessories

Product	Code no.
Gland seal, 10 pcs. ¹⁾	013G0290

¹⁾ The gland seal of the valve can be replaced under pressure, i.e. while the installation is in operation.

System

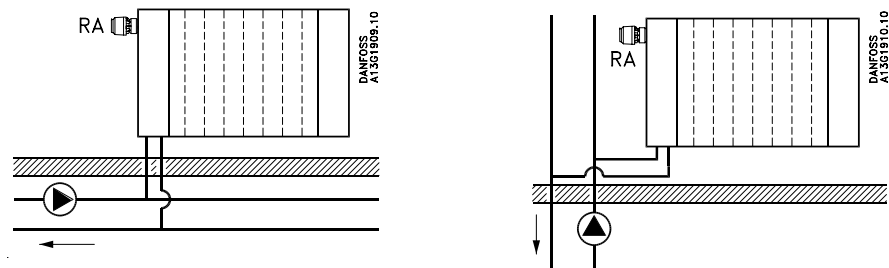

Design

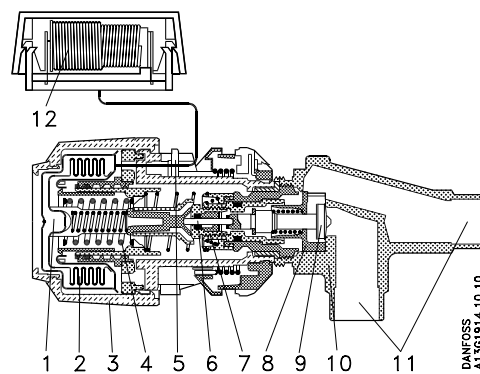

- 1. Condensate
- 2. Bellows
- 3. Setting dial
- 4. Setting spring
- 5. Limitation pin
- 6. Pressure pin
- 7. O-ring seal
- 8. Throttle nozzle
- 9. Valve cone
- 10. Valve body
- 11. Soldering connections
- 12. Remote sensor

Materials in contact with water

Valve body and other metal parts	Ms 58 brass
Throttle nozzle	PPS
O-ring	EPDM
Valve cone	NBR
Pressure pin in gland seal	Chrome steel

Presetting

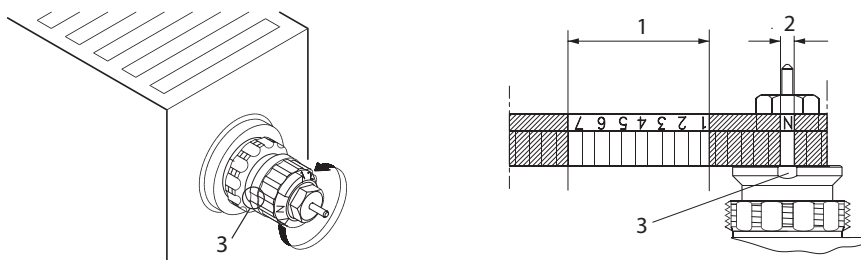

1. Presetting range
2. Factory setting and one-pipe system
3. Reference mark

In a one-pipe installation, the setting 'N' must be used.

The presetting values of the integrated valves can be adjusted easily and accurately without the use of tools (factory setting: 'N'):

Setting 'N' can be used as a flushing position if the system has to be flushed out because of dirt problems.

- Remove the protective cap or the thermostatic sensor
- Find the reference mark
- Turn the setting ring until the desired presetting aligns with the reference mark.

When the radiator thermostat has been installed, the presetting is protected against unintended regulation.

The presetting is controlled directly without the use of equipment. After installation in the radiator, the reference mark of the valves will not always be positioned in the same place.

For Danfoss elements RA 2000, RAS-C, RAS-D and RAE, a theft protection device is available; this also provides added security against unwanted adjustment of the preset values.

Presetting can be selected infinitely variably within the range of 1 to 7. At setting 'N' the valve is fully open. Setting in the shaded areas of the drawing should be avoided.

Dimensions

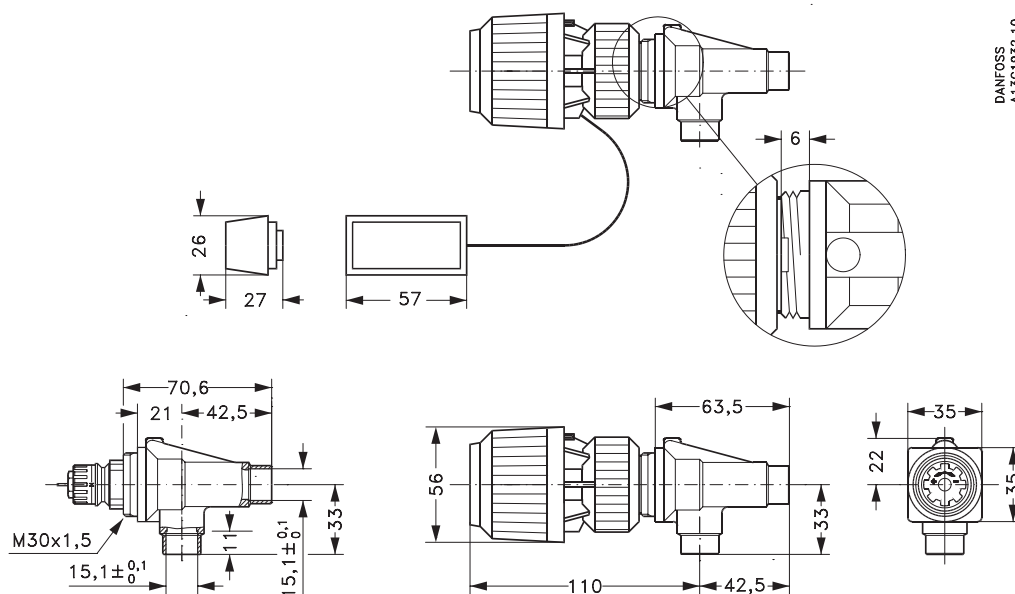

DANFOSS
A13G1932.10

Capacities

RA – capacities with P-band between 0.5 K and 2 K

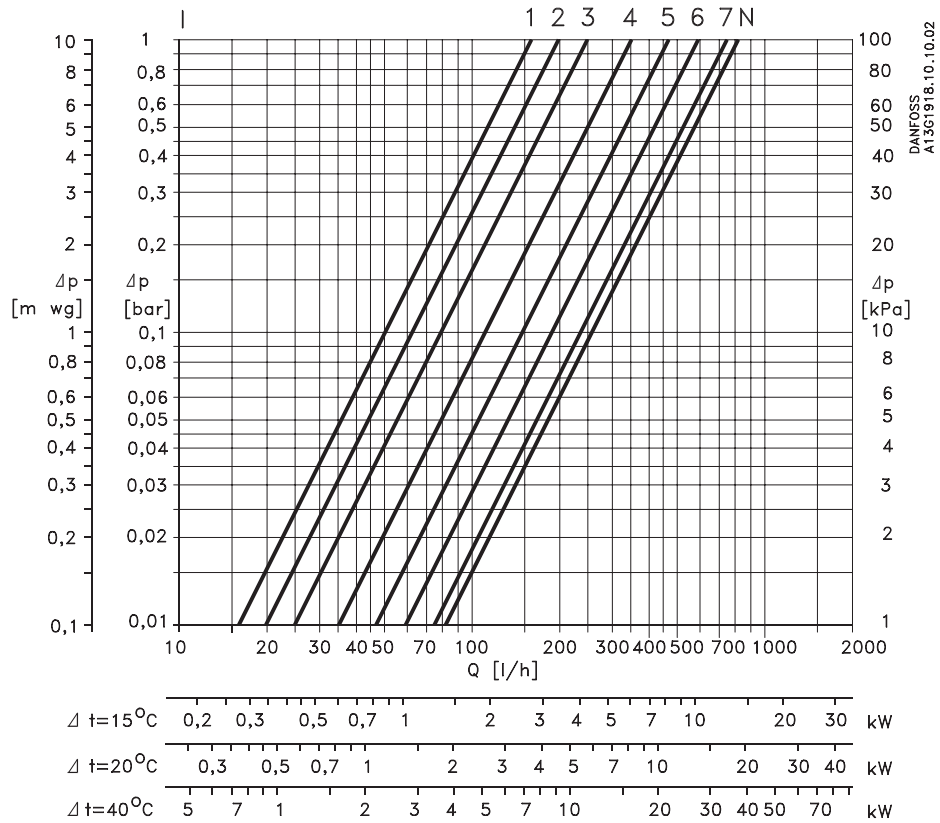

Sizing Example

Known values

Heat demand: $\phi = 1500 \text{ kcal/h}$
 System temperature drop: $\Delta t = 20 \text{ }^\circ\text{C}$
 Differential pressure: $\Delta p = 0.10 \text{ bar}$

The setting is found in the capacity diagram above: *Presetting 3.*

If the sizing point found is between two settings, the highest setting is chosen.

Calculation

Water quantity: $Q = \frac{\phi}{\Delta t} = \frac{1500}{20} = 75 \text{ l/h}$

$k_v = \frac{Q}{\sqrt{\Delta p}} = \frac{0.075}{\sqrt{0.1}} = 0.23 \text{ m}^3/\text{h}$

Alternatively, the settings can be found directly in the table "Ordering and specifications".

Mounting of Thermostatic Sensor

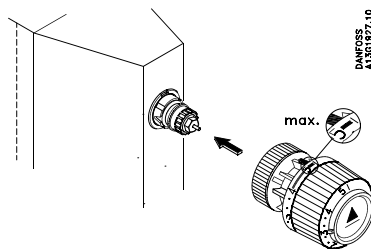

The valve body is designed for mounting in the inlet of the radiator observing the direction of the flow arrow.

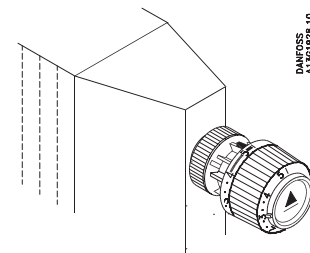

When using a built-in sensor, the valve body should be mounted with the gland seal horizontal.

During the construction period, before the sensor is mounted, the heating can be manually regulated by means of the protective cap on the valve body.

Instructions for installation are enclosed.

The sensor should always be placed where the room air can circulate freely around it.

An open-end spanner is used for mounting the sensor onto the valve body.

Replacement of the Gland Seal

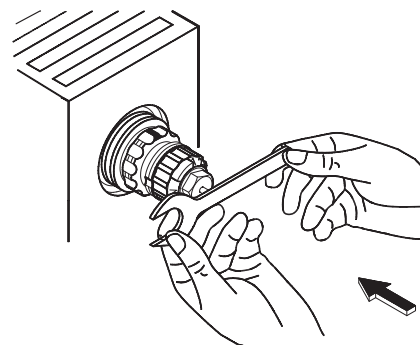
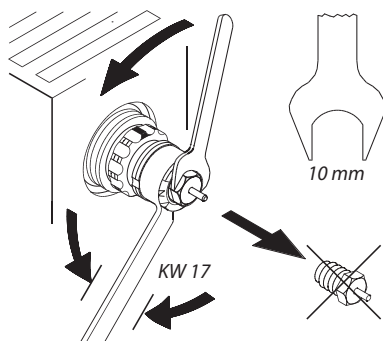

Firmly

While the system is in operation, the gland seal can be replaced by means of a spanner, KW 10.

After mounting the gland seal, press pin firmly to ensure proper contact to the valve spindle.

Hold the setting ring using a 12-edge ring spanner, KW 17.

Danfoss A/S
Heating Solutions
Haarupvaenget 11
8600 Silkeborg
Denmark
Phone: +45 7488 8000
Fax: +45 7488 8100
Email: heating.solutions@danfoss.com
www.heating.danfoss.com

Danfoss can accept no responsibility for possible errors in catalogues, brochures and other printed material. Danfoss reserves the right to alter its products without notice. This also applies to products already on order provided that such alterations can be made without subsequential changes being necessary in specifications already agreed. All trademarks in this material are property of the respective companies. Danfoss and the Danfoss logotype are trademarks of Danfoss A/S. All rights reserved.
