

Mounting and Installation Guide

Instantaneous Water Heaters for apartments, single- and multi-family houses

Instantaneous water heaters, based on the flow principle.

Akva Lux II

Instantaneous water
heaters, based on the
flow principle

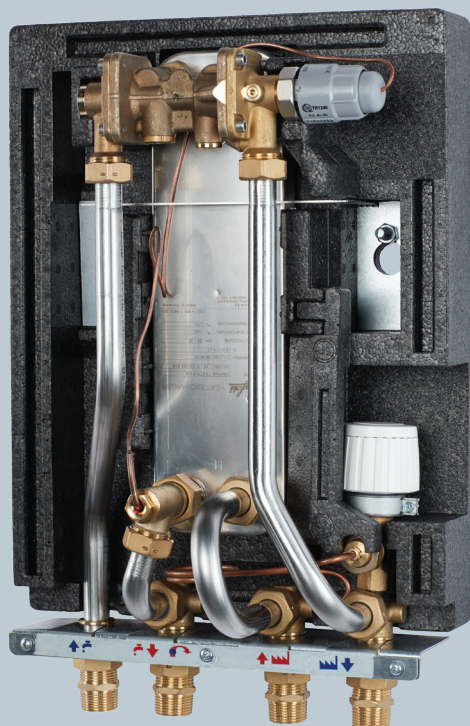

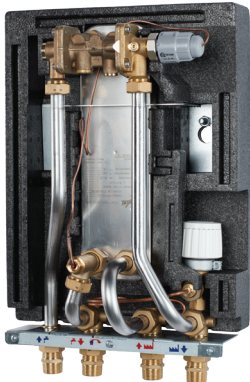

Akva Lux II

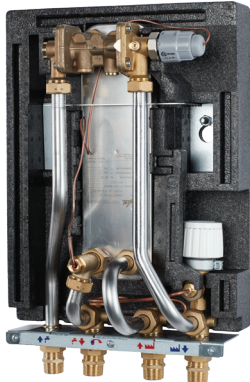

Akva Lux II XBS



Akva Lux II GW



Akva Vita II

1.0 Contents

1.0 Contents 2 3.0

2.0 Safety notes..... 3

3.0 Storage and Handling..... 3

4.0 Disposal 3

5.0 Easy start-up..... 4

 5.1 Connections, Dimensioned sketches and Start-up 4

6.0 Akva Lux II - Diagram example, measurements and main components..... 5

7.0 Akva Lux II XBS - Diagram example, measurements and main components..... 6

8.0 Akva Lux II GW - Diagram example, measurements and main components 7

9.0 Akva Vita II - Diagram example, measurements and main components 8

10.0 Mounting..... 9

 10.1 Test and connections..... 9

 10.2 Systems with domestic hot water (DHW) recirculation..... 9

 10.3 Recirculation connection - Akva Lux II..... 10

 10.4 Recirculation connection - Akva Lux II GW and Akva Vita II..... 12

11.0 Akva Lux II - Instructions 14

12.0 Akva Lux II GW - Instructions 15

13.0 Akva Vita II - Instructions..... 16

14.0 Maintenance..... 17

 14.1 Maintenance of gasketed heat exchanger, Akva Lux II GW..... 18

15.0 Trouble shooting..... 20

16.0 EU Declaration of Conformity 22

17.0 Commissioning Certificate..... 23

18.0 Guidelines for water quality in Danfoss brazed heat exchangers..... 24

Instructions

Water Heaters

2.0 Safety notes

Instructions

This operating manual should be read carefully before installation and start-up of the water heater. The manufacturer accepts no liability for damages or faults that result from non-compliance with the operating manual. Please read and follow all the instructions carefully to prevent accidents, injury and damage to property. The risk of persons being injured and equipment damaged increases considerably if the recommended permissible operating parameters are exceeded. Installation, assembly work, first start-up and maintenance work may be carried out only by qualified and authorized personnel in compliance with the safety regulations (both heating and electrical work).

Energy source

The water heater is designed for district heating as the primary source of energy. However, also other energy sources can be used where the operating conditions allow it and always are comparable to district heating.

Application

The water heater is designed only to operate with water and other heating media may not be used. Connect the water heater to the house piping in a frost-free room, where the temperature does not exceed 50 °C and the humidity does not exceed 80%. Do not cover or wall up the water heater or in any other way block the entrance to the station.

Choice of material

Choice of materials always in compliance with local legislation.

Corrosion protection

The risk of equipment corrosion increases considerably if recommended permissible chloride compounds are exceeded.

All pipes are made of min. AISI 304 (heating) and min. AISI 316 (domestic water) stainless steel as well as brass. Components for domestic water, however, primarily in dezincification-resistant brass. Heat exchangers are made of stainless steel and are copper-soldered or steel-soldered. Surfaces in contact with water can be subject to two problems, limescale formation and corrosion.

The nature of the water will be of great importance in this context, where the pH value, chlorides, gases, etc., have a decisive effect on how much lime is deposited and how aggressive the water is.

The temperature also has a great influence in this context. For example the corrosion rate increases by a factor of 2 to 3 for every 10° C temperature rise.

With knowledge of the chemical water composition and operating conditions of a heating system, the risk of scaling and corrosion can be assessed. Based on that, recommendations can be made to avoid scaling and/or corrosion problems in the components.

See item 18, page 23 for more detailed Guidelines for Water Quality in Danfoss brazed heat exchangers and recommended Chloride concentration to avoid Stress Corrosion Cracking.

Safety valve(s)

We recommend mounting of safety valve(s), however, always in compliance with local regulations.

Noise level

≤ 55 dB

PTC2+P controller for domestic hot water

The controller is preset from factory and sealed with a red sticker. This sealing must not be broken. The warranty becomes void if the sealing is broken.



3.0 Storage and Handling

If the water heater is stored before installation, make sure that the place is dry and heated. Humidity max. 80% and storage temperature 5-70 °C).

Do not stack the unit higher than factory shipped. Units that are shipped in cardboard packaging are to be lifted by the carrying handles of the packaging. Transport / removals over great distances should be carried out on pallets.

During and after unpacking, the water heater can be lifted by hand in the mounting plate. Note that lifting in the pipes can cause leaks. ALWAYS re-tighten.

4.0 Disposal

Dispose of packaging material in accordance with local regulations.

This product consists of materials, which must not be disposed of together with domestic waste.

Switch off the complete power supply and demount all connection pipes, dismantle the product and sort the components in various groups before disposal. Always observe the disposal rules of the local legislation.

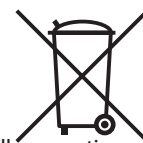

Connections

The water heater must be equipped with features that ensure that the water heater can be separated from all energy sources (also power supply).

Reach

All products of the Akva Lux II series comply with the provisions of the REACH regulation. We are therefore obliged to inform our customers about the presence of substances according to the SVHC candidate list, if they are present. We hereby inform you: This product contains brass parts containing lead (CAS 7439-92-1) in a concentration above 1% (w/w).

Potential equalization/grounding

Potential equalization is an electrical equalizing connection to secure against user contact with dangerous voltage, which may occur for example between two piping systems. Potential equalization reduces corrosion in heat exchangers, water heaters, district heating substations and plumbing installations. Equalization of potentials should be effected according to local regulations.

Warning of hot surfaces

Parts of the water heater may become hot and hot surfaces can cause serious burns. Please be extremely cautious in close proximity to the water heater.

Warning of high pressure and high temperature

The stations work at a maximum supply temperature from the district heating network of 110°C and the stations work with a operating pressure of 16 bar, which may put the user at risk of burns from touching the surface or from the emissions of hot media (water/steam). The risk of persons being injured and equipment damaged increases considerably if the recommended permissible operating parameters are exceeded.

Emergency

In case of danger or accidents - fire, leaks or other dangerous circumstances - interrupt all energy sources to the station if possible, and seek expert help.

In case of discoloured or bad-smelling domestic hot water, close all shut-off valves on the water heater, inform the operating personnel and call for expert help immediately.

Warning of transport damage

Before water heater installation, please make sure that the water heater has not been damaged during transport. Always transport the water heater with the utmost care and caution.

IMPORTANT - Tightening of connections

Due to vibrations during transport all flange connections, screw joints and electrical clamp and screw connections must be checked and tightened before water is added to the system. After water has been added to the system and the system has been put into operation, re-tighten ALL connections. **(Do not overstrain! - See page 9, item 10.1)**



Handling

When working on the water heater suitable safety shoes must be worn.



NOTE: Interventions/rework on our components results in loss of warranty.

5.0 Easy start-up

5.1 Connections, Dimensioned sketches and Start-up

Follow the below start-up instructions for easy start-up.

Water heater types:

- A. Akva Lux II - fully insulated water heater with PTC2+P
- B. Akva Lux II GW - water heater with gasketed heat exchanger and PTC2+P
- C. Akva Vita II with PM2+P

Connections:

- 1. Domestic cold water (DCW) inlet
- 2. Domestic hot water (DHW) outlet
- 3. District heating (DH) supply
- 4. District heating (DH) return

Connect the water heater to the household piping according to the labels placed on the water heater as well as the instructions in this manual.

Note that the unit must always be connected with the pipes down unless the unit is prepared for pipe connection both up and down.

If the household piping includes hot water recirculation the substation must be connected to the recirculation piping.

Switching to recirculation is possible from a constructional point of view, requiring only an additional circulation set. **The components for DHW recirculation are not part of the delivery and must be ordered separately and mounted on site. See page 9-13 for further information about recirculation.**

It is to be recommended to prepare the substation for recirculation before mounting it on the wall.

Start-up

01. Fix the water heater on a solid wall with two strong bolts, screws, expansion plugs or the like.
02. Close all shut-off valves, before the water heater is connected to the household piping.
03. **IMPORTANT!** Tighten **all** connections, as vibrations during transport and handling may have caused leaks.
04. For systems with safety valve, a discharge outlet must be established in compliance with local regulations.
05. If the household plumbing system includes hot water recirculation the water heater must be connected to the hot water recirculation system. **Remember always to mount circulation pump and non-return valve on the circulation pipe and to mount safety valve on the DCW inlet.** The pump must be installed so that the pump is pumping water towards the water heater. The pump must be connected to power supply, **but do not switch on the pump.**
06. Carefully open the ball valve on DH supply. Subsequently open the remaining ball valves.
07. Check the water heater and the household piping carefully for any leaks.
08. Perform pressure testing of the household installation in compliance with local regulations.
09. Switch on circulation pump (if any).
10. Finally adjust the water heater according to the enclosed installation instructions.

IMPORTANT! Heating and cooling of the system may cause leaks. Therefore tightening of all connections may be necessary after commencement of operation.

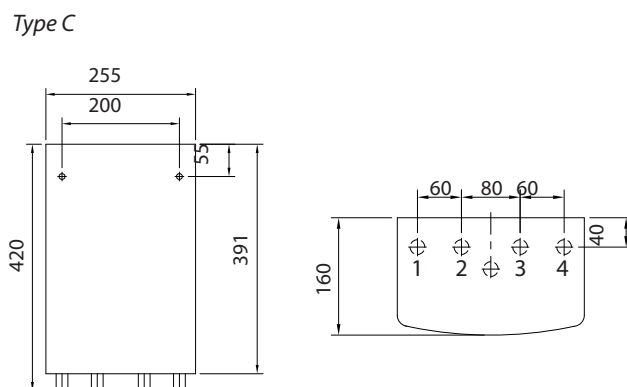
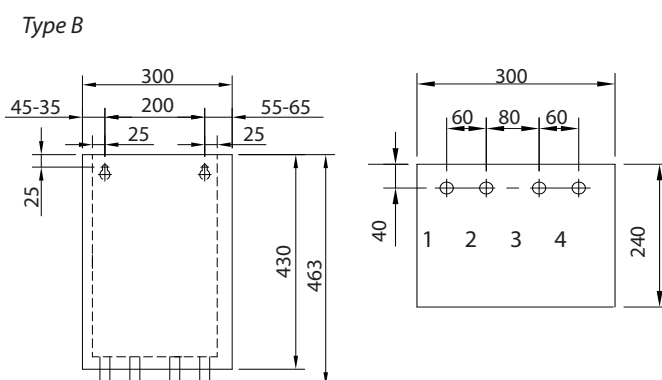
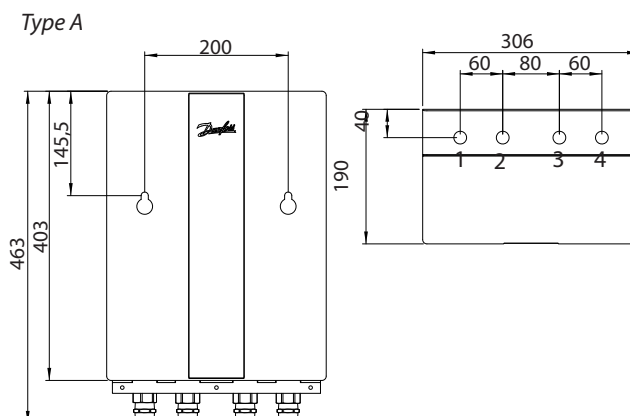

6.0 Akva Lux II - Diagram example, measurements and main components

- 2. Plate heat exchanger DHW
- 5. Filter for PTC2+P controller
- 14. Connection for DHW circulation
- 34. Hexagon Nipple 3/4"
- 38. PTC2+P controller
- 40. Danfoss FJVR thermostat for bypass/circulation

Option: Circulation set

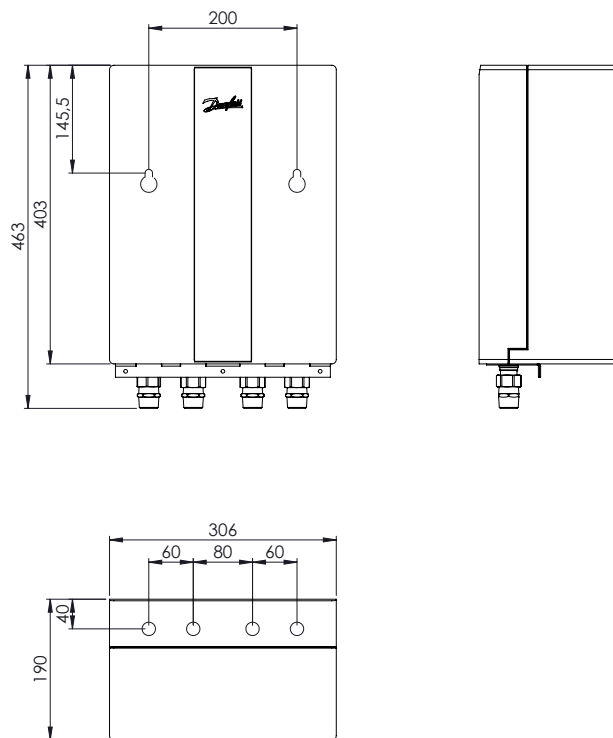
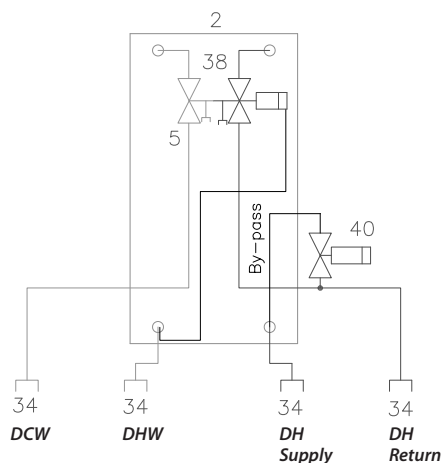

Main components

- 1. Plate heat exchanger, brazed, DHW
- 2. DHW controller PTC2+P
- 3. Bypass thermostat Danfoss FJVR
- 4. Sensor PTC2+P / sensor pocket
- 5. Connection nipples
- 6. Mounting bracket
- 7. Insulation cover (back part)
- 8. Insulation cover (front part)
- 9. White-lacquered cover (optional equipment)

* brazing material: Copper

- F. Filter on cold water inlet
- C. The water heater is prepared for DHW recirculation
Fittings for DHW recirculation connection are supplied loose.

See instructions on page 10.

Accessories

Circulation set for mounting on site
Code No. 004U8442

Safety set
Code No. 004U8554

Cover H 410 x W 310 x D 210 mm
Code No. 004U8663

Ball valve 3/4" ext.-int. thread incl. gasket, L = 60 mm
145H3744

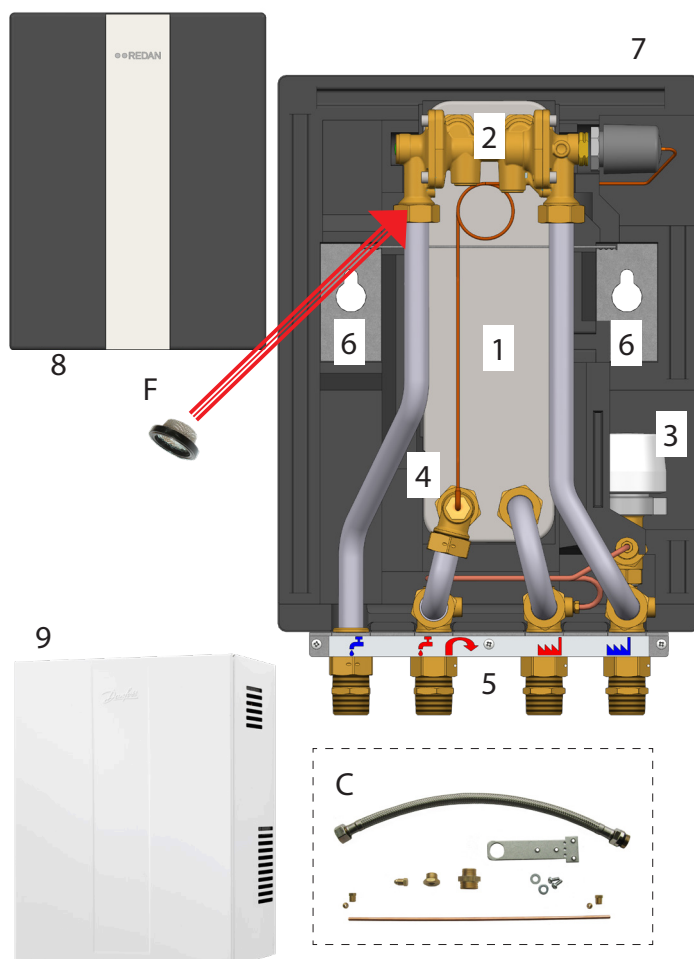

7.0 Akva Lux II XBS - Diagram example, measurements and main components

- 2. Plate heat exchanger DHW
- 5. Filter for PTC2+P controller
- 14. Connection for DHW circulation
- 34. Hexagon Nipple 3/4"
- 38. PTC2+P controller
- 40. Danfoss FJVR thermostat for bypass/circulation

Option: Circulation set

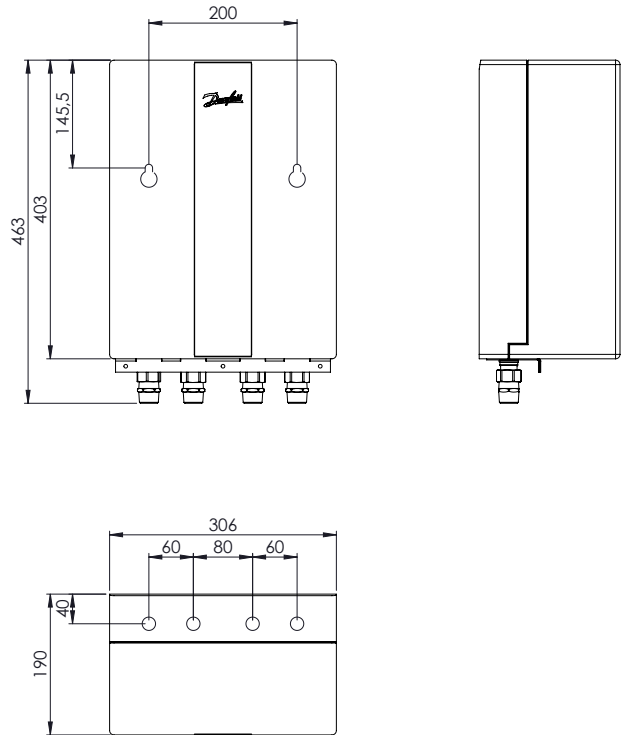
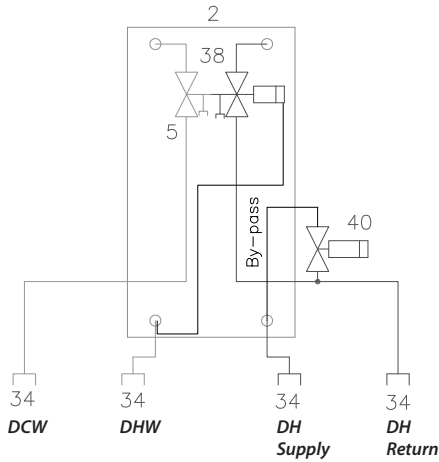

Main components

- 1. Plate heat exchanger, brazed*, DHW
- 2. DHW controller PTC2+P
- 3. Bypass thermostat Danfoss FJVR
- 4. Sensor PTC2+P / sensor pocket
- 5. Connection nipples
- 6. Mounting bracket
- 7. Insulation cover (back part)
- 8. Insulation cover (front part)
- 9. White-lacquered cover (optional equipment)

* brazing material; Stainless steel

- F. Filter on cold water inlet
- C. The water heater is prepared for DHW recirculation
Fittings for DHW recirculation connection are supplied loose.

See instructions on page 10.

Accessories

Circulation set for mounting on site
Code No. 004U8442

Safety set
Code No. 004U8554

Cover H 410 x W 310 x D 210 mm
Code No. 004U8663

Ball valve 3/4" ext.-int. thread incl. gasket, L = 60 mm
145H3744

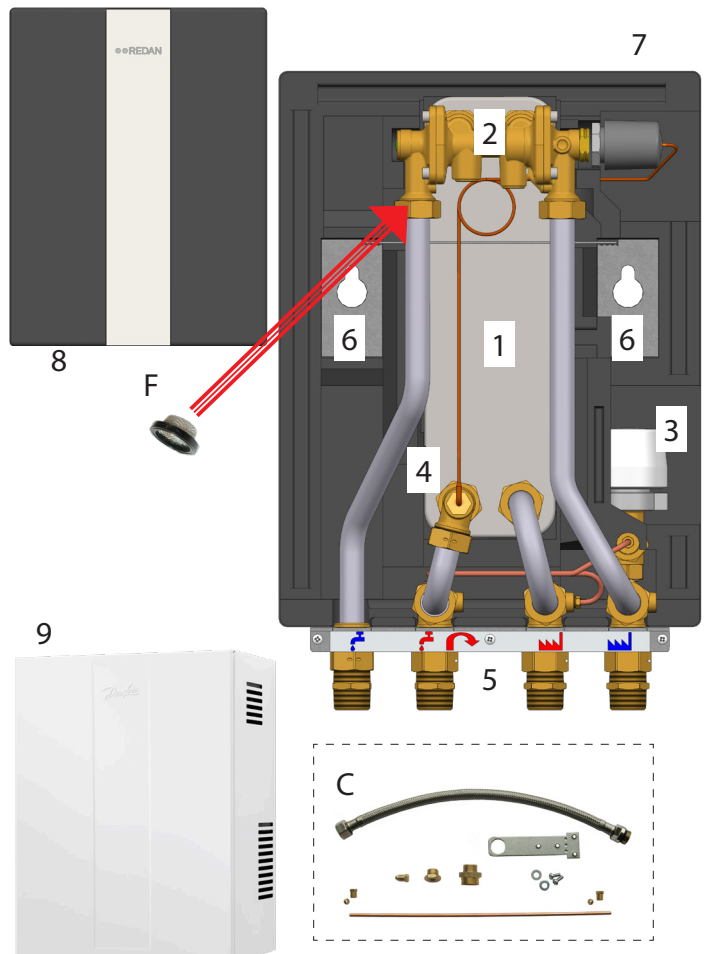

8.0 Akva Lux II GW - Diagram example, measurements and main components

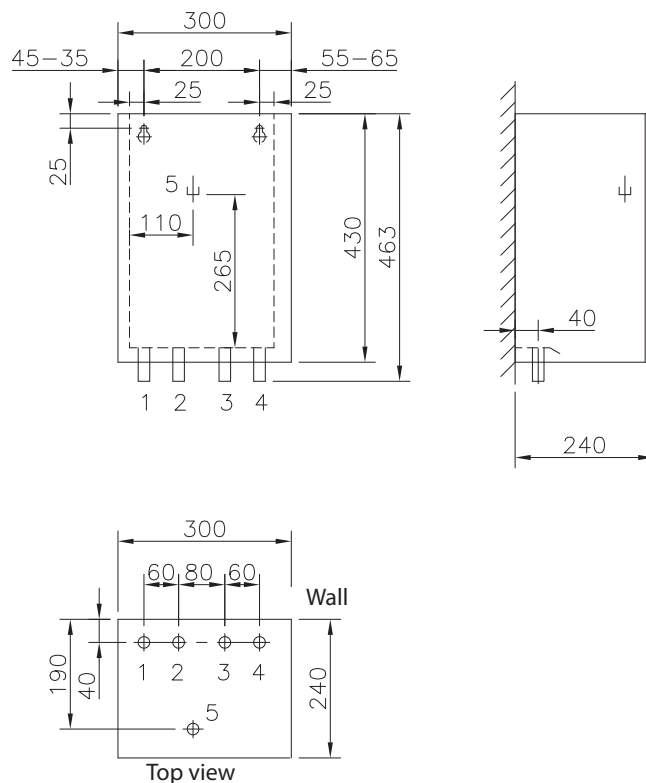
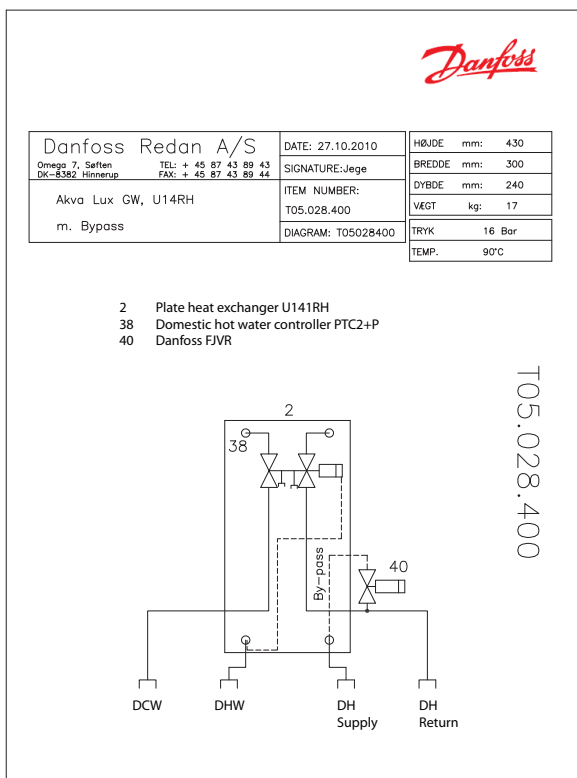

Main components

1. Plate heat exchanger, gasketed, DHW
 2. DHW controller PTC2+P
 3. Bypass thermostat Danfoss FJVR
 4. Sensor PTC2+P / sensor pocket
 5. Connection nipples
 6. White-lacquered cover (optional equipment)
- F. Filter on cold water inlet
C. The water heater is prepared for DHW recirculation
Fittings for DHW recirculation connection are supplied loose.

See instruction on page 12.

Accessories

Circulation set for mounting on site
Code No. 004U8442

Safety set
Code No. 004U8554

Cover H 410 x W 310 x D 210 mm
Code No. 004U8663

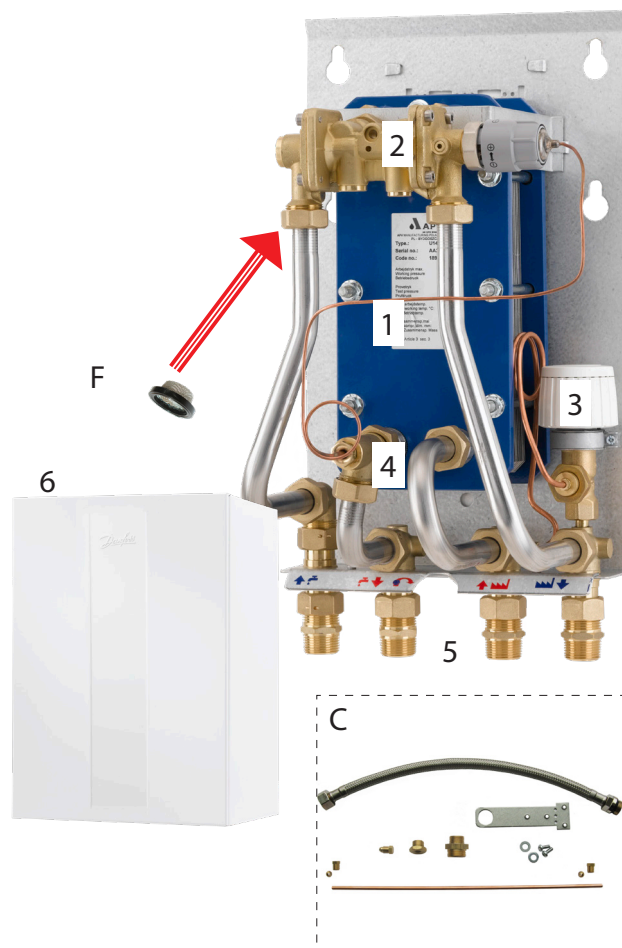

9.0 Akva Vita II - Diagram example, measurements and main components

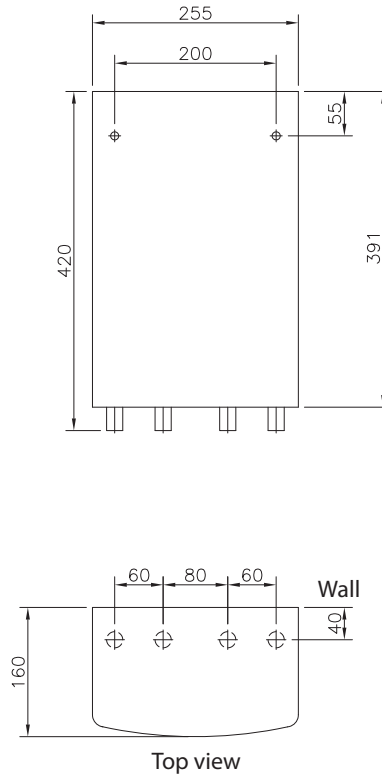
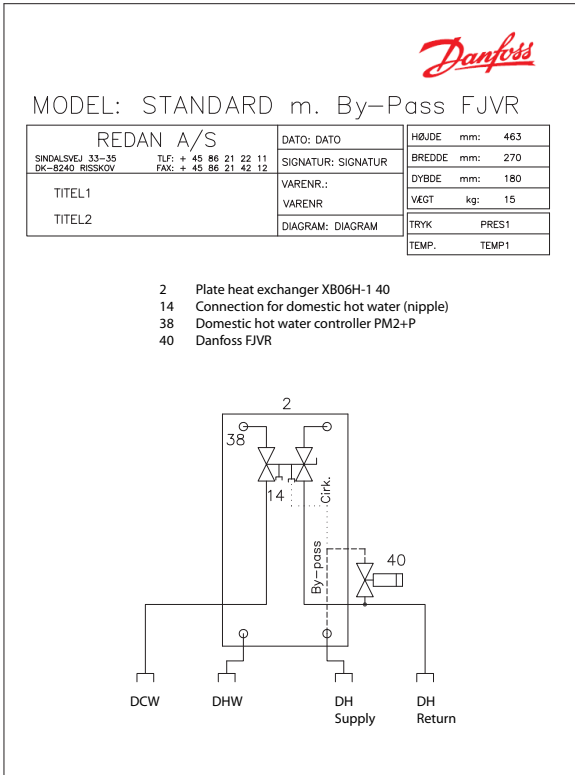

Main components

1. Plate heat exchanger, brazed, DHW
 2. DHW controller PM2+P
 3. Bypass thermostat Danfoss FJVR
 4. Connection nipples
 5. Brushed stainless steel cover (optional equipment)
- F. Filter on cold water inlet
 C. The water heater is prepared for DHW recirculation
 Fittings for DHW recirculation connection are supplied loose.

See instructions on page 12.

Accessories

Circulation set for mounting on site
 Code No. 004U8442

Safety set
 Code No. 145H3001

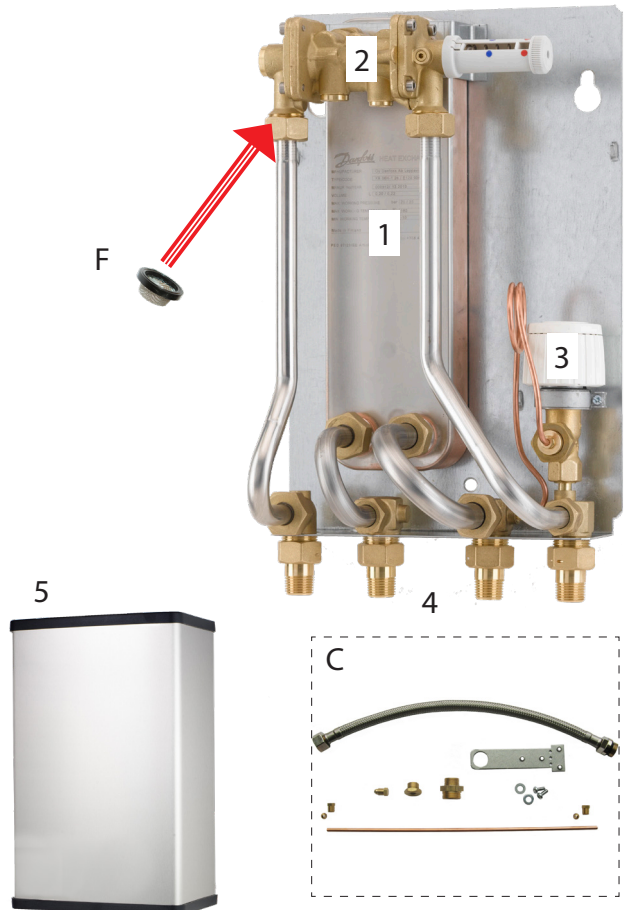

10.0 Mounting

Necessary assembly, start-up and maintenance work must be performed by qualified and authorized personnel only, and always in compliance with local regulations and this instruction manual. The water heater must be easily accessible, enabling maintenance work without undue discomfort.

The water heater is intended for wall mounting and the mounting sheet on the back of the water heater has got holes for screw installation. Lift the water heater in the mounting plate and fix it to a solid wall, which has the necessary load-bearing capacity, in a workmanlike manner with two strong bolts, screws or expansion plugs.

Note, The Akva Lux II water heaters are not mechanically fixed in the insulation back and must be handled by lifting in both pipes and insulation simultaneously.

All pipes and connections must be cleaned and rinsed before start-up. After that the strainers should be cleaned.

A label for each of the different connections is placed on the water heater. Connect the water heater to the household system according to these symbols as well as the instructions in this manual.

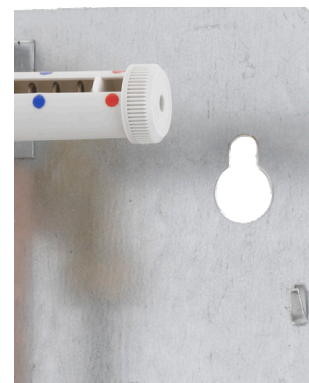
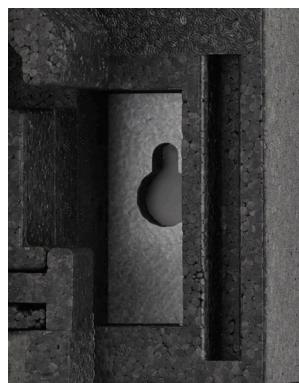

10.1 Test and connections

Check and tighten all connections before adding water to the system, as vibrations during transport may have caused leaks.

After having added water to the system, tighten all the connections before performing leak test. If the water heater operates in accordance with the dimensioning basis, re-tighten the connections and take the water heater into continuous use.

NB!

Please note that the connections may be supplied with EPDM rubber gaskets. **Therefore take care not to overstrain the union nuts, as this may result in leaks.** The manufacturer accepts no liability for leaks that result from overstrain of union nuts.



10.2 Systems with domestic hot water (DHW) recirculation

If the household plumbing system includes hot water recirculation the water heater must be connected to the hot water recirculation system.

Circulation set is not included in the delivery and must be ordered separately.

It is to be recommended to prepare the substation for recirculation before mounting it on the wall.

The recirculation pipe in your household plumbing system must be connected to a nipple, mounted on the circulation pipe of the substation. - **See pages 10 to 13 for information about preparation of substation for and connection to the DHW recirculation system.**

Remember always to mount circulation pump and non-return valve on the circulation pipe and to mount safety valve on the DCW inlet. The pump must be installed so that the pump is pumping water towards the water heater.

If a time-controlled pump is used, it is to be recommended that the circulation water temperature is set to approx. 35 °C.

If the circulation pump (outside the unit) is switched off for a longer period, it is to be recommended that the Danfoss FJVR thermostat is closed during the same period.

NOTE!

Please note that water heaters with Danfoss AVE expansion unit must **not** be used on systems with DHW recirculation.

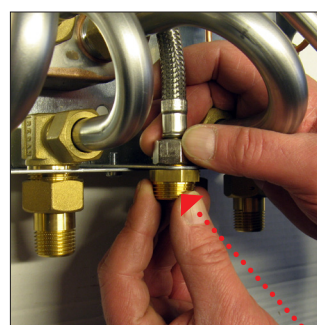

Circulation pipe connection

Instructions

Water Heaters

10.3 Recirculation connection - Akva Lux II and Akva Lux II XBS

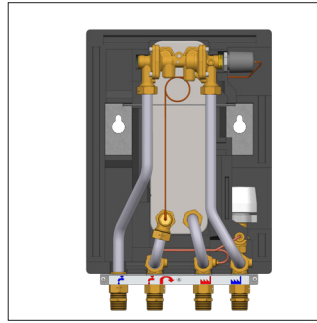
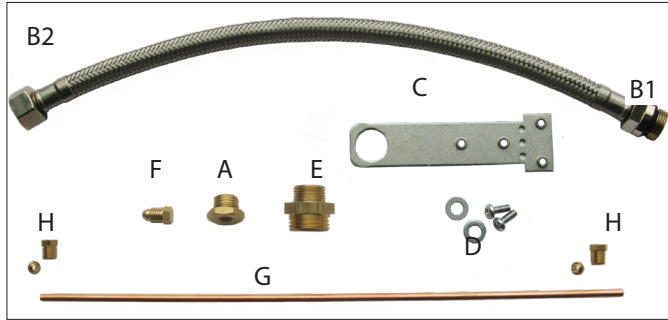

Fig. 1
Demount plugs (6 mm Allen key) from controller.

Fig. 2
Mount nipple A in controller.

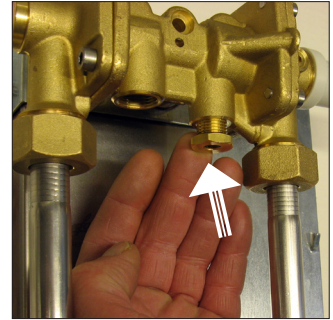
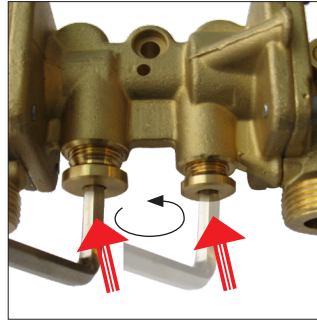

Fig. 1

Fig. 2

Fig. 3
Mount circulation hose end B1 in controller.

Fig. 4
Unscrew the 3 screws on locking rail.

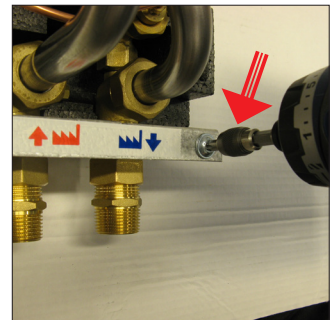
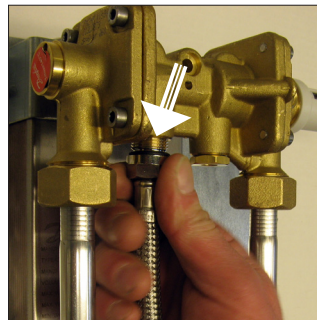

Fig. 3

Fig. 4

Fig. 5
Demount locking rail.

Fig. 6
Demount support rail, as shown.

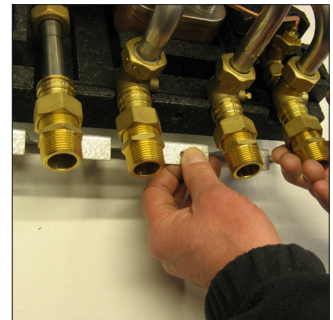
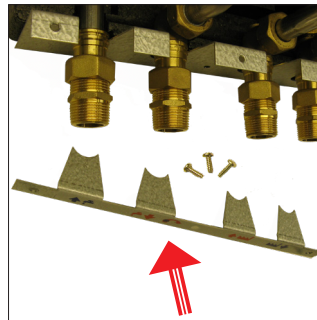

Fig. 5

Fig. 6

Fig. 7
GB: Place bracket C on support rail, as shown.

Fig. 8
Fix bracket C on support rail, by fastening the screws D lightly.

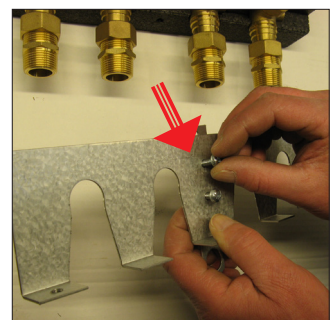
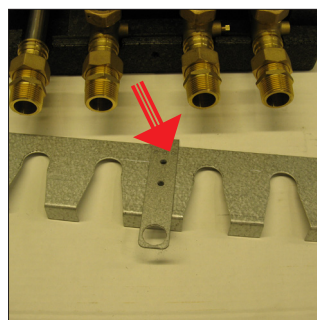

Fig. 7

Fig. 8

Instructions

Water Heaters

Fig. 9
Demount capillary tube from T-piece.

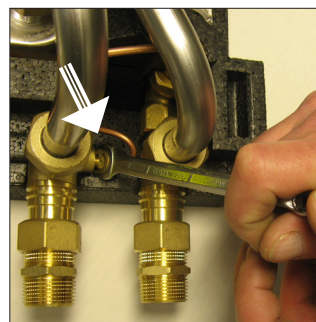

Fig. 9

Fig. 10
Mount m8 x 1 screw plug F in T-piece.

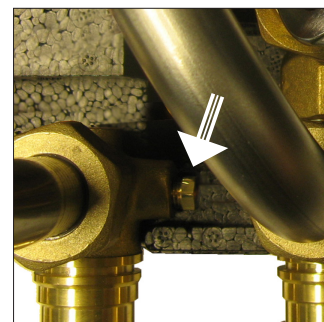

Fig. 10

Fig. 11
Demount capillary tube from T-piece as shown.

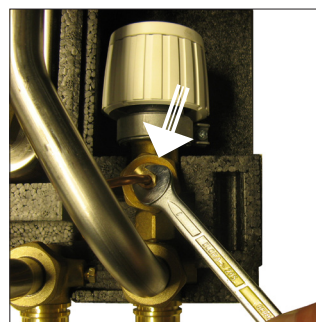

Fig.11

Fig. 12
Mount support rail and tighten screws D with your screwdriver, as shown.

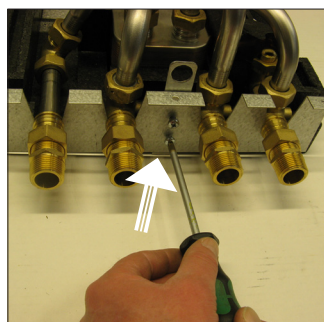

Fig. 12

Fig. 13
Fix locking rail to support rail.

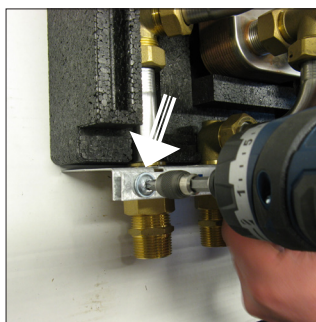

Fig. 13

Fig. 14
Fit new capillary tube G on nipple B by means of union nut and cutting ring H. - Tighten with single end wrench.

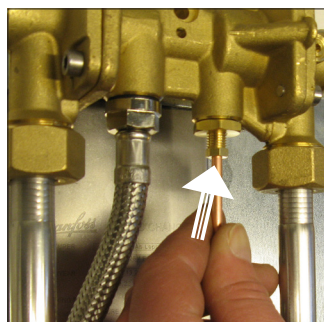

Fig. 14

Fig. 15
Fit the other end of the capillary tube G on T-piece by means of union nut and cutting ring H. - Tighten with single end wrench.

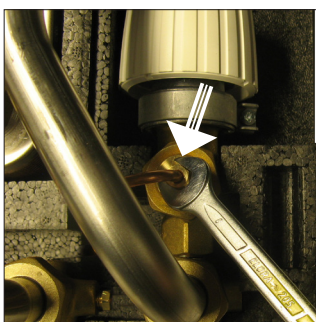

Fig. 15

Fig. 16
Fix circulation hose end B2 and nipple E in bracket, as shown

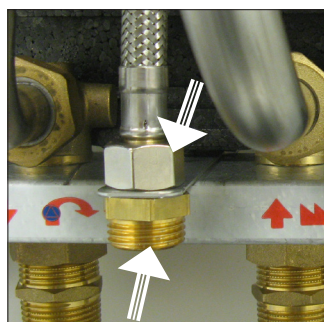
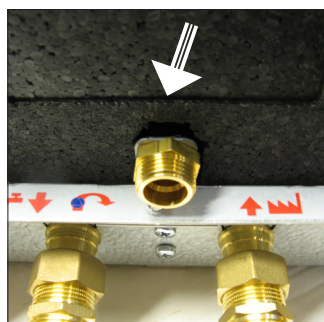
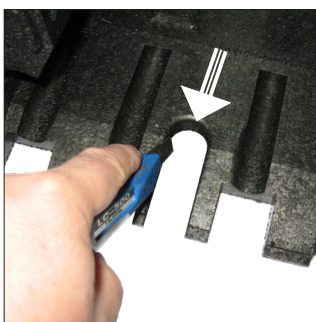
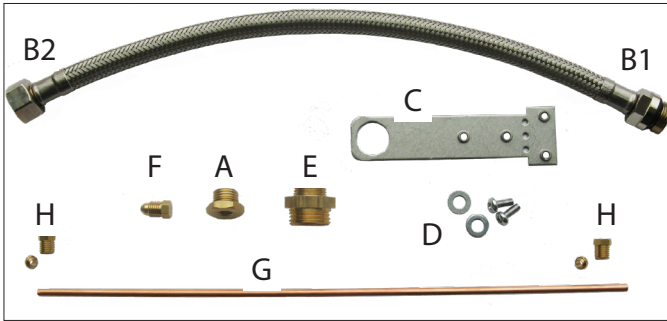

Fig.16

Fig. 17 + 18
Cut out a section of the front insulation as shown, in order to be able to fix the front insulation cover after mounting of circulation pipe.



10.4 Recirculation connection - Akva Lux II GW and Akva Vita II



Remember always to mount circulation pump and non-return valve on the circulation pipe and to mount safety valve on the DCW inlet. The pump must be installed so that the pump is pumping water towards the water heater. This not part of the circulation set.

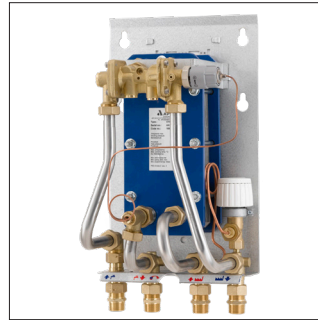

Akva Lux II GW

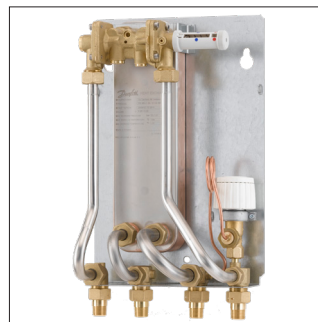

Akva Vita II

Fig. 1

Demount plugs (6 mm Allen key) from controller.

Fig. 2

Mount nipple A in controller.

Fig. 3

Mount circulation hose end B1, as shown.

Fig. 4

Prepare bracket C for mounting on mounting plate by making a 90-degree bend on one end, using a pair of pliers. This applies only to type C Akva Vita II. - For type B, Akva Lux II GW, it is not necessary to make a 90-degree bend on the bracket before mounting.

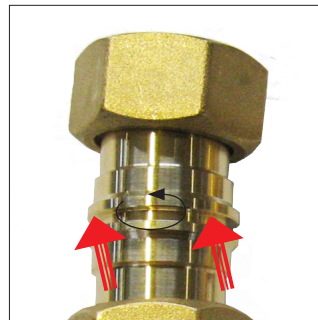

Fig. 1

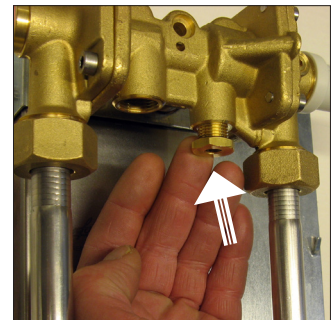

Fig. 2

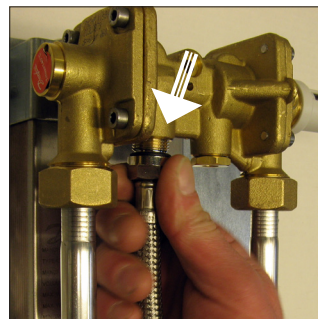

Fig. 3



Fig. 4

Instructions

Water Heaters

Fig. 5

Place bracket C on mounting plate as shown.

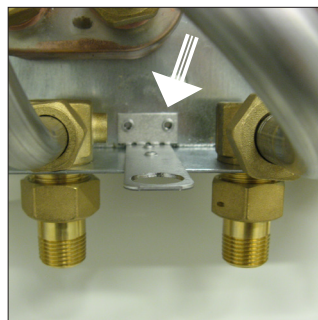

Fig. 5

Fig. 6

Fasten bracket C on mounting plate with nuts and bolts D.

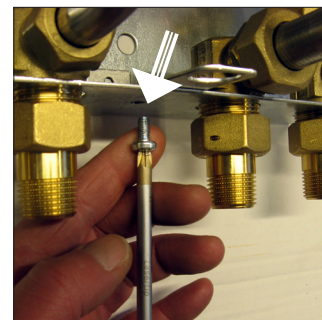

Fig. 6

Fig. 7

Mount circulation hose end B2 and nipple E in bracket as shown.

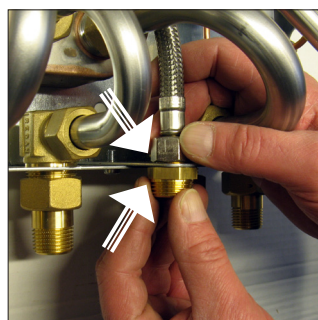

Fig. 7

Fig. 8

Demount capillary tube from T-piece.

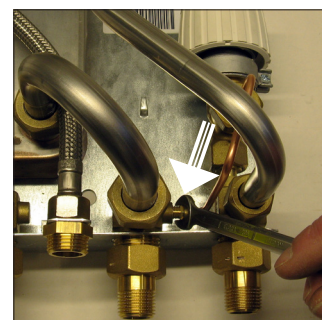

Fig. 8

Fig. 9

Demount capillary tube from bypass thermostat.

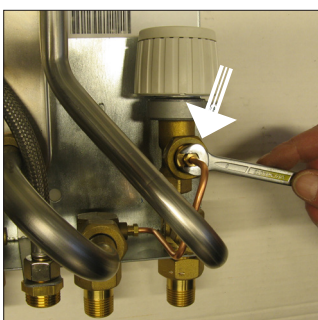

Fig. 9

Fig. 10

Mount M8 x 1 screw plug F in T-piece.

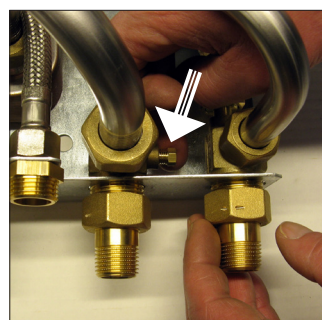

Fig. 10

Fig. 11

Fit new capillary tube G on nipple B by means of union nut and cutting ring H. - Tighten with single end wrench.

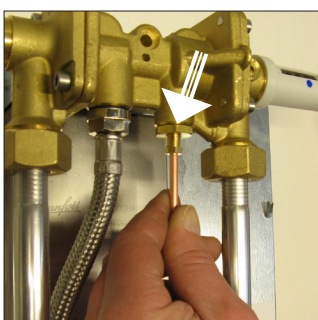

Fig. 11

Fig. 12

Fit the other end of the capillary tube G on T-piece by means of union nut and cutting ring H. - Tighten with single end wrench.

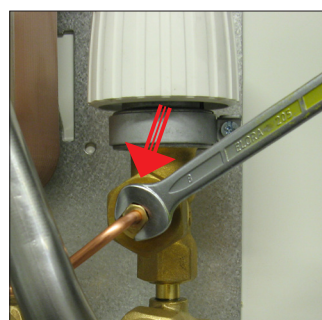

Fig.12

11.0 Akva Lux II - Instructions

11.1 General

Variants

PLEASE NOTE that your water heater may look different than the water heater shown, as variants with other components may be supplied. The control function, however, is basically as described below.

Maintenance and setting

Remove the front insulation without using tools, just carefully pull the insulation right side. Fix the front insulation with a slight pressure on

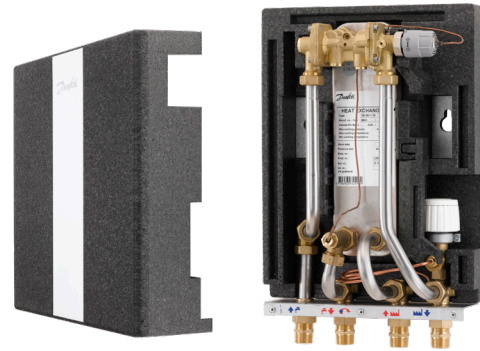

Fully insulated water heater. The domestic hot water is prepared in a heat exchanger based on the flow principle and the temperature is controlled by a combined hydraulic and thermostatic self-acting controller PTC2+P controller with integrated differential pressure controller, which blocks the flow of primary and secondary side flow through the heat exchanger

Note: The Akva Lux II water heaters are not mechanically fixed in the insulation back and must be handled by lifting in both pipes and insulation simultaneously.

Danfoss PTC2+P controller (1) for DHW. The DHW temperature is adjusted by turning the lever towards "+" (warmer) or "-" (colder).

Start by turning the handle **clockwise** - until stop /until the handle can not be turned anymore. Then turn the handle **counter-clockwise** until the temperature of the tap water is approx. 48 °C at normal use (7-8 l/min). The temperature should never exceed 55 °C to avoid lime scale

1



Handle for temperature setting

Bypass thermostat (default).

As a standard the Akva Lux II are equipped with a bypass thermostat, Danfoss FJVR (2), which ensures that hot water is produced immediately, when tapping starts. It is recommended to set the thermostat in pos. 3.

If the water temperature rises too slowly it can be necessary to set the thermostat at higher value.

Alternatively a DHW circulation system must be installed.

2



Circulation thermostat / control change to circulation.

If the water heater is connected to the DHW recirculation system in the building, the FJVR thermostat (2) will function as a circulation thermostat and control the circulation water temperature, independently of the set DHW temperature. It is recommended to set the thermostat in pos. 3.

For recirculation connection please refer to pages 9-11.

The photo to the right shows a water heater, on which circulation hose and capillary tube have been mounted and connected to the domestic hot water controller, enabling the temperature of the circulating water to be controlled by the FJVR thermostat.

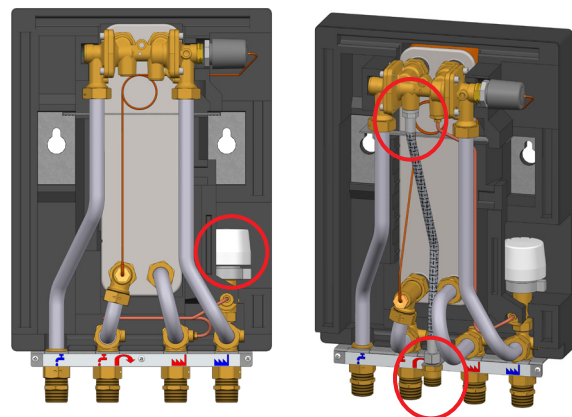

Instructions Water Heaters

12.0 Akva Lux II GW - Instructions

12.1 General

Variants

PLEASE NOTE that your water heater may look different than the water heater shown, as variants with other components may be supplied. The control function, however, is basically as described below.

Maintenance and setting

The cover can be removed without using tools. For separation and cleaning of plate heat exchanger see page 18.

12.2 Description

The water heater is based on a gasketed stainless steel plate heat exchanger. The domestic hot water is prepared in a heat exchanger based on the flow principle and the temperature is controlled by a combined hydraulic and thermostatic self-acting controller PTC2+P controller with integrated differential pressure controller, which blocks the flow of primary and secondary side flow through the heat exchanger immediately after completion of the tapping process.



12.3 DHW temperature control

Danfoss PTC2+P controller (1) for DHW. The DHW temperature is adjusted by turning the lever towards "+" (warmer) or "-" (colder). Start by turning the handle **clockwise** - until stop /until the handle can not be turned anymore. Then turn the handle **counter-clockwise** until the temperature of the tap water is approx. 48 °C at normal use (7-8 l/min). The temperature should never exceed 55 °C to avoid lime scale precipitation.

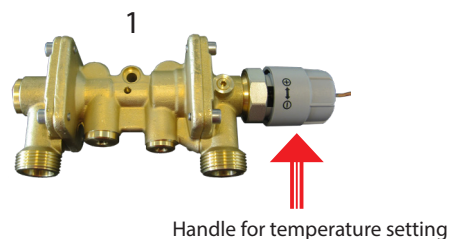

12.4 By-pass or circulation thermostat

Bypass thermostat (default).

As a standard the Akva Lux II GW is equipped with a bypass thermostat, Danfoss FJVR (2), which ensures that hot water is produced immediately, when tapping starts. It is recommended to set the thermostat in pos.3. If the water temperature rises too slowly it can be necessary to set the thermostat at higher value. Alternatively a DHW circulation system must be installed.

Circulation thermostat / control change to circulation.

If the water heater is connected to the DHW recirculation system in the building, the FJVR thermostat (3) will function as a circulation thermostat and control the circulation water temperature, independently of the set DHW temperature. It is recommended to set the thermostat in pos 3.

For recirculation connection please refer to pages 9 + 12-13.

The photo to the right shows a water heater, on which circulation hose and capillary tube have been mounted and connected to the domestic hot water controller, enabling the temperature of the circulating water to be controlled by the FJVR thermostat.

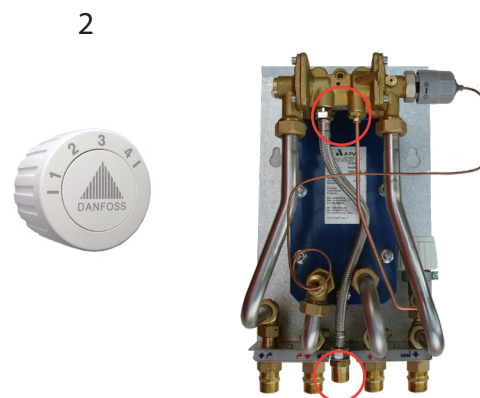

13.0 Akva Vita II - Instructions

13.1 General

PLEASE NOTE that your water heater may look different than the water heater shown, as variants with other components may be supplied. The control function, however, is basically as described below.

Maintenance and setting

The cover can be removed without using tools. For cleaning of plate heat exchanger see page 17.

13.2 Description

The water heater is based on a brazed plate heat exchanger. The domestic hot water temperature is controlled by a hydraulic self-acting controller PM2+P controller with integrated differential pressure controller, which blocks the flow of primary and secondary side flow through the heat exchanger immediately after completion of the tapping process.



13.3 DHW temperature control

Danfoss PM2+P controller (1) for DHW. The DHW temperature is adjusted by turning the lever towards the red (warmer) or blue (colder) mark. Start by turning the handle clockwise - until the temperature indicator is exactly opposite the blue dot. Then turn the handle **counter-clockwise** until the temperature of the tap water is approx. 48 °C at normal use (7-8 l/min). The temperature should never exceed 55 °C to avoid lime scale precipitation.

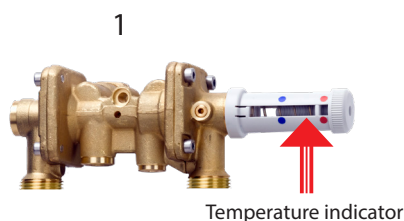

(NOTE! The temperature indicator must be between the blue and the red dot, otherwise the controller will close.

13.4 By-pass or circulation thermostat

Bypass thermostat (default).

As a standard the Akva Vita II is equipped with a bypass thermostat, Danfoss FJVR (2), which ensures that hot water is produced immediately, when tapping starts. It is recommended to set the thermostat in pos.3. If the water temperature rises too slowly it can be necessary to set the thermostat at higher value. Alternatively a DHW circulation system must be installed.

Circulation thermostat / control change to circulation.

If the water heater is connected to the DHW recirculation system in the building, the FJVR thermostat (3) will function as a circulation thermostat and control the circulation water temperature, independently of the set DHW temperature. It is recommended to set the thermostat in pos 3.

For circulation connection please refer to pages 9 + 12-13.

The photo to the right shows a water heater, on which circulation hose and capillary tube have been mounted and connected to the domestic hot water controller, enabling the temperature of the circulating water

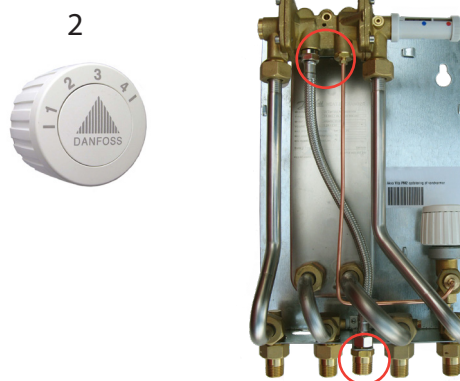

14.0 Maintenance

Maintenance work

Is only to be carried out by qualified and authorised personnel.
Visual control and heat meter reading is to be performed by the janitor or other supervisor (the heat meter is not part of the delivery)

Inspection

The operator or other authorised personnel is obliged to perform inspections at regular intervals and if necessary carry out maintenance work according to these and other instructions. Within the scope of the above maintenance work all strainers should be cleaned (see photo to the right), all connections should be tightened and the operation of the safety valves should be checked by turning the valve head in the indicated direction.

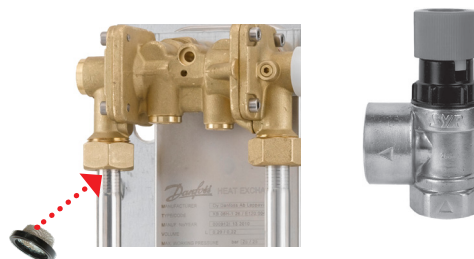

Rinsing / cleaning of plate heat exchanger

Brazed heat exchangers can be rinsed. For optimum cleaning the flow rate should be a min. of 1.5 times normal flow rate, preferably in back-flush mode. This will remove any deposits formed on the inside of the plate heat exchanger. In case of more serious deposits, a cleaning liquid, approved by Danfoss (f.ex. Radiner FI) can be pumped through the heat exchanger. Both are environmentally friendly cleaning fluids and can be disposed of through the usual domestic sewerage system. Afterwards rinse thoroughly with large amounts of water.

Deacidification of brazed plate heat exchanger

After long operation, because of the large variations in temperature and as oxygenous water is used on the secondary side, the heat exchangers are especially subject to calcification. Any deacidification of the plate heat exchanger is done as shown on the drawing to the right. For brazed plate heat exchangers weak inhibited acid solutions (e.g. 5% formic, acetic or phosphoric acid) may be used.

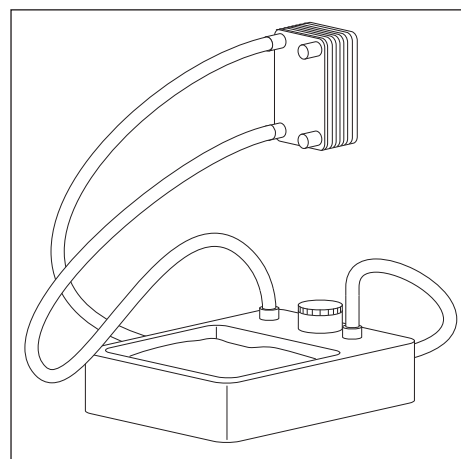

Deacidification of gasketed plate heat exchanger (Akva Lux II GW)

See page 18.

Measures after maintenance work

After maintenance work and before switching the system on again:

- Check that all screwed connections are tight.
- Check that all safety features, covers, that were removed, have been replaced properly.
- Clean the working area and remove any spilled materials.
- Make sure that all tools, materials and other equipment that were used, have been removed from the working area.
- Connect to energy supply and check for leaks.
- Vent the system.
- If necessary adjust the system again.
- Make sure that all safety features on the device and the system work properly.

Cooling / Return temperature reading

The cooling, i.e. the temperature difference between district heating supply and district heating return is of great importance for the total heat economy. It is therefore very important to observe the supply and return temperatures. Normal temperature difference is 30-35 °C.

Please note, that the lowest district heating return temperature is directly dependent on the return temperature from the heating circuit and the recirculation circuit. Therefore, please observe these return temperatures.

Cooling of the water heater alone

During the tapping process the cooling will typically be 30-35°C. During standby the return temperature from the water heater will normally increase a little. The heat meter will in this situation register only a very limited consumption, as the water volume is very small.

On water heaters connected to the DHW recirculation system the calorimeter measures the heat loss in the circulation pipe.

Tightening of connections

When reading the heat meter, all fittings and connections should be checked for leaks. If leaks are detected, contact qualified and authorized personnel immediately.

14.1 Maintenance of gasketed heat exchanger, Akva Lux II GW



Never open the plate heat exchanger until the unit has cooled below 40° C (105° F)

Never open a plate heat exchanger, which is under pressure from any source.

Never open a plate heat exchanger with piping to the follower or connector grids.

Deacidification of gasketed heat exchanger (cleaning without opening the heat exchanger, i.e. cleaning in place)

Close the shut-off valves to the water heater and drain the heat exchanger as much as possible.

Disassemble all connected pipes as well as the controller from the heat exchanger and if necessary release it from the mounting plate.

Cleaning in place is accomplished by circulating a suitable cleaning solution* through the secondary side (the domestic hot water side) of the heat exchanger, as shown to the right.

Cleaning in place works best in the reverse direction of normal flow. The cleaning solution must be circulated at sufficient velocity to flush out the product and be able to dissolve the fouling/calification on the plates. Great care must be taken to select a proper cleaning solution that does not damage plates or gaskets.

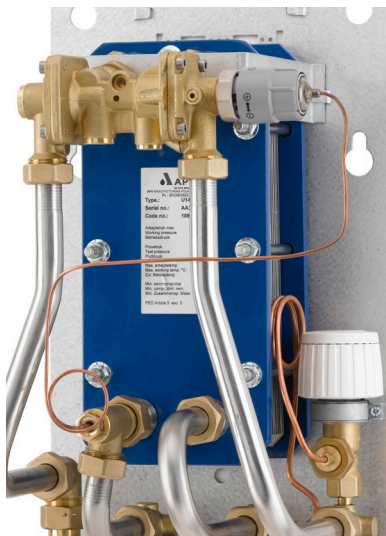

Example of cleaning:

1. Drain product residues, cooling and heating media.
2. Rinse with cold or lukewarm water.
3. Circulate warm cleaning fluid solution.
4. Rinse with warm water or warm water with softener added.
5. Rinse with cold or lukewarm water.

In simple cases cleaning can also be effected without circulation, but by pouring a cleaning fluid solution into the system. After some time of standing, flush the solution with clean water.

Insufficient cleaning is most often due to:

- Insufficient circulation rate.
- Insufficient cleaning time or temperature.
- Insufficient concentration of the cleaning agent.
- Excessive periods of operation.

*Cleaning agents

Mineral lime scale deposits are removed with nitric acid (HNO₃) - max. concentration 0,5% - max. temperature 65°C (150 °F). 0.5% concentration corresponds to 0,58 litre 62% HNO₃ per 100 litres water.



Note! Excess nitric acid can seriously damage NBR gaskets and other types of rubber gaskets.

Several alternatives to nitric acid can be used e.g. phosphoric acid up to 5% and 85 °C.



Note! Do not use chlorine-containing agents such as hydrochloric acid (HCl).

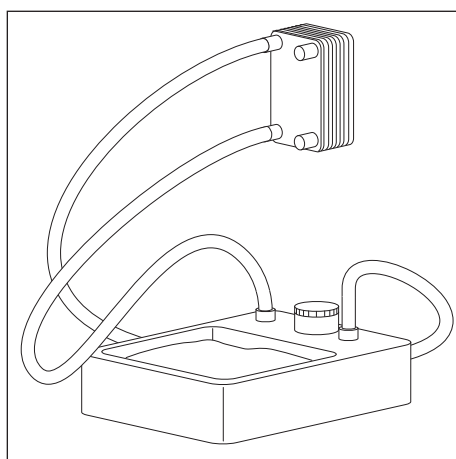

Manual cleaning (by separating the heat exchanger)

If cleaning in place is not sufficient, we recommend that the heat exchanger is replaced through our special "exchange for new" arrangement.

Exchange for new

Please contact our local sales department to learn more about this arrangement.

Tightening (in case of minor leaks)

In case of a minor leak the heat exchanger can be tightened to the original compressed dimension. The bolts must not be slackened or tightened indiscriminately. They must be loosened/tightened alternately on the left and right side and in a crosswise pattern.

Loosening and tightening of tie bars in the heat exchanger can normally be accomplished with ratchet wrenches/spanners.

Measure and note that compressed dimension of the plate pack before loosening the tie bars. On the nameplate of the heat exchanger you will find the minimum and maximum compressed dimension of the plate pack.

If the heat exchanger is separated we recommend that you obtain a separate instruction manual for the gasketed heat exchangers from our sales department.

15.0 Trouble shooting

If operating disturbances occur, the following basic features should be checked before carrying out actual troubleshooting:

- there is pressure on the system. - see manometer on system
- the system is connected correctly,
- the system is connected to electricity - pump and automatic

- the strainer on the district heating supply is clean
- the district heating supply temperature is at normal level
- the differential pressure is higher than or equal to the normal / local differential pressure on the district heating network. - If in doubt, ask the district heating plant.

15.1 Troubleshooting - Domestic hot water

Problem	Possible cause	Solution
Variations in temperature	Non-return valve on the circulation line defective (leads to mixing - and the circulation water pipes become cold during tapping).	Replace non-return valve.
Low temperature / variations in temperature at the draining points	Non-return valve in thermostatic mixer tap in the bathroom defective - leads to mixing of cold and hot water-. Note that variations in temperature may occur at other draining points/water taps in the household piping! REMEMBER, to check all the mixer taps in the house!	Replace mixer tap, or non-return valve only.
Not enough pressure on the hot water	Strainer in cold water meter or in the cold water supply line clogged .	Clean strainer (cold water meter possibly in consultation with the water supply company).
Long waiting time	Circulation pump out of operation - (not part of the dly).	Check whether the pump is running - whether the pump is receiving power. control that there is no air in the pump housing - see pump manual.
No domestic hot water	Defective or wrongly set differential pressure controller (not part of the dly). Strainer on DH supply clogged.	Check the functions of the differential pressure controller - clean valve seat and capillary tube if required. Clean strainer.
DHW temperature too low	See above. Non-return valve on the circulation line defective (leads to mixing - and the circulation water pipes become cold during tapping).	See above. Replace non-return valve.
DHW temperature too high	Defective DHW controller.	Check the functions of the controller, and replace if required.
Declining temperature during tapping	Defective or wrongly set differential pressure controller (not part of the dly). Air in capillary tubes	Check the functions of the differential pressure controller - clean valve seat and capillary tubes if required. Air and rinse capillary tubes.

Problem	Possible cause	Solution
<p>Especially for systems with plate heat exchanger for domestic hot water heating. Typical problems with systems, for which the DHW supply is generated by a plate heat exchanger.</p>		
<p>Dedlicing temperature during tapping</p>	<p>Calified heat exchanger Short-circuiting of / defective heat exchanger</p>	<p>Clean heat exchanger with acid solution or replace heat exchanger Replace heat exchanger</p>
<p>Poor cooling</p>	<p>Calified heat exchanger</p>	<p>Clean heat exchanger with acid solution or replace heat exchanger</p>
<p>Discoloured water (for a longer period)</p>	<p>Short-cuiting of heat exchanger</p>	<p>Replace heat exchanger</p>
<p>Not enough pressure on the hot water</p>	<p>Calified heat exchanger</p>	<p>Clean heat exchanger with acid solution or replace heat exchanger</p>

16.0 EU Declaration of Conformity



Danfoss A/S

DK-8430 Nordborg
Denmark
CVR nr.: 20 16 57 15

Telephone: +45 7488 2222
Fax: +45 7440 0049

EU DECLARATION OF CONFORMITY

Danfoss A/S
Danfoss Heating Segment – District Heating

Declares under our sole responsibility that the

Products: Substations in PED kat. 0 without electrical equipment

**Type: Akva Vita, Akva Lux, Akva Les and Akva Therm waterheater,
Akva Vita II TD, Akva Vita II TDP-F and Akva Vita TDP
Akva Lux II TD, Akva Lux TDP, Akva Lux II TDP, Akva Lux II TDP-F and Complete TDP-F,
Akva Les II TD,
EvoFlat FSS, EvoFlat Waterheater and EvoFlat Four Pipe
Distribution module SG
Metering station**

Covered by this declaration is in conformity with the following directive(s), standard(s) or other normative document(s), provided that the product is used in accordance with our instructions.

Machinery Directive 2006/42/EC

DS/EN 60204-1/A1:2009, Safety of machinery – Part 1 – General Requirements.
DS/EN 12100:2011, Safety of machinery – Risk assessment.

Date <i>28/4-17</i>	Issued by Signature: <i>[Signature]</i> Name: Jan Behrnsen Title: Engineering Expert	Date <i>26/4-17</i>	Approved Signature: <i>[Signature]</i> Name: Katja Bredgaard Title: Quality Manager
------------------------	--	------------------------	---

Danfoss Redan A/S only vouches for the correctness of the English version of this declaration. In the event of the declaration being translated into any other language, the translator concerned shall be liable for the correctness of the translation

ID No: DHREUD01

Revision No: B

Page 1 of 1

17.0 Commissioning Certificate

Commissioning certificate

The substation is the direct link between the district heating supply network and the household piping system. All supply pipes and the pipes in the household piping system must be checked and rinsed before commissioning. Once the system has been filled with water, all pipe connections must be retightened before performing pressure test for leaks. The dirt strainers must be cleaned and the substation must be adjusted in accordance with the instructions in this manual.

It is important to comply with all technical regulations and the applicable legislation in every respect.

Installation and commissioning must only be performed by trained, authorised personnel.

The substation is checked in the factory for leaks before delivery. Leaks are however possible due to vibrations caused by transport, handling and heating of the system and therefore it is important to check all connections and to retighten if necessary before commissioning. Please note that the connections may feature EPDM gaskets! **Therefore it is important that you DO NOT OVER-TIGHTEN the connections.** Over-tightening may result in leaks. Leaks caused by over-tightening or failure to retighten connections are not covered by the warranty.

To be filled-out by the installer

This substation has been retightened, adjusted and commissioned

on the:

Date/Year

by installer:

Company name (stamp)

18.0 Guidelines for water quality in Danfoss brazed heat exchangers

ENGINEERING
TOMORROW



Danfoss A/S
Danfoss Heating Segment - DEN
BU HEX - Local Inspection Center Kamnik Slovenia

Guidelines for water quality in Danfoss brazed heat exchangers with plates of EN 1.4404 ~ AISI 316L

Danfoss has prepared this guideline for the water quality of tap water and district heating water used in plate heat exchangers of stainless steel (EN 1.4404 ~ AISI 316L) brazed with pure copper (Cu), copper -nickel (CuNi) or Stainless Steel (StS). It is important to point out that the water specification is not a guarantee against corrosion, but it must be considered as a tool to avoid the most critical water applications.

Parameter	Unit	Value or concentration	Plate	Brazing material		
			AISI 316L W.Nr. 1.4404	Cu	CuNi	StS
pH		< 6.0	o	-	-	o
		6.0 – 7.5	+	o/-	o	+
		7.5 – 10.5	+	+	+	+
		> 10.5	+	o	o	+
Conductivity	µS/cm	< 10	+	+	+	+
		10 – 500	+	+	+	
		500 – 1000	+	o	+	+
		> 1000	+	-	o	+
Free Chlorine	mg/l	< 0.5	+	+	+	+
		0.5 – 1	o	+	+	+
		1 – 5	-	o	o	o
		> 5	-	-	-	-
Ammonia (NH ₃ , NH ₄ ⁺)	mg/l	< 2	+	+	+	+
		2 – 20	+	o	o	+
		> 20	+	-	-	+
Alkalinity (HCO ₃ ⁻)	mg/l	< 60	+	+	+	+
		60 – 300	+	+	+	+
		> 300	+	o	+	+
Sulphate (SO ₄ ²⁻)	mg/l	< 100	+	+	+	+
		100 – 300	+	o/-	o	+
		> 300	+	-	-	+
HCO ₃ ⁻ / SO ₄ ²⁻	mg/l	> 1.5	+	+	+	+
		< 1.5	+	o/-	o	+
Nitrate (NO ₃)	mg/l	< 100	+	+	+	+
		> 100	+	o	+	+
Manganese (Mn)	mg/l	< 0.1	+	+	+	+
		> 0.1	+	o	o	+
Iron (Fe)	mg/l	< 0.2	+	+	+	+
		> 0.2	+	o	+	+
* Hardness ratio [Ca ²⁺ , Mg ²⁺]/[HCO ₃ ⁻]	/	0 – 0.3	+	-	-	+
		0.3 – 0.5	+	o/-	+	+
		> 0.5	+	+	+	+

+	Good corrosion resistance
o	**Corrosion could happen when more parameters are evaluated with o
o/-	Risk of corrosion
-	Use is not recommended

* Hardness ration limits defined per experience and internal tests in Danfoss laboratory

** In case of three or more parameters evaluated with o consultancy is needed with Consultant for Corrosion & Microbiology or BU HHE Representative

Recommended Chloride concentration to avoid Stress Corrosion Cracking (SCC) in the stainless-steel plates:

Application temperature	Chloride concentration
at T ≤ 20°C	max 1000 mg/l
at T ≤ 50°C	max 400 mg/l
at T ≤ 80°C	max 200 mg/l
at T ≥ 100°C	max 100 mg/l



Danfoss Redan A/S

redan.dk • +45 8743 8943 • redan@danfoss.com

Any information, including, but not limited to information on selection of product, its application or use, product design, weight, dimensions, capacity or any other technical data in product manuals, catalogues descriptions, advertisements, etc. and whether made available in writing, orally, electronically, online or via download, shall be considered informative, and is only binding if and to the extent, explicit reference is made in a quotation or order confirmation. Danfoss cannot accept any responsibility for possible errors in catalogues, brochures, videos and other material. Danfoss reserves the right to alter its products without notice. This also applies to products ordered but not delivered provided that such alterations can be made without changes to form, fit or function of the product.

All trademarks in this material are property of Danfoss A/S or Danfoss group companies. Danfoss and the Danfoss logo are trademarks of Danfoss A/S. All rights reserved.
