



Installation guide

Pressure switch, KP 1, KP 1W, KP 1A, KP 2, KP 5, KP 5A, KP 6W, KP 6B, KP 6S, KP 6AW, KP 6AB, KP 6AS, KP 7W, KP 7B, KP 7S

06G0R9750

06G0R9750

Refrigerants:

R22, R134a, R404A, R407A, R407C, R407F, R410A*) R422B, R422D, R448A, R449A, R452A, R507A, R513A, R717**)

For complete list of approved refrigerants, go to <http://products.danfoss.com/all-products/>

*) only for KP 6W, KP 6B, KP 6S, KP 6AW, KP 6AB, KP 6AS

**) only for KP 1A, KP 5A, KP 6AW, KP 6AB, KP 6AS

KP 1, KP 2,
KP 5, KP 6, KP 7



KP 1, KP 2,
KP 5, KP 6, KP 7

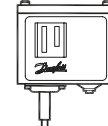

KP 1A, KP 5A

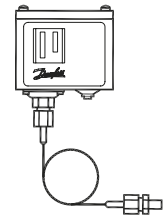

Ambient temperatures / Mounting requirements

-40 – 65 °C
-25 – 65 °C (PED approved units)

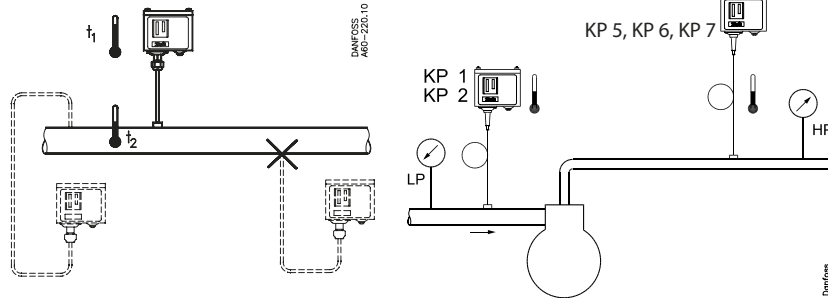

Relative humidity RH: 30 – 98%
Vibrations resistance: 4 g (10 – 1000 Hz)

Connections

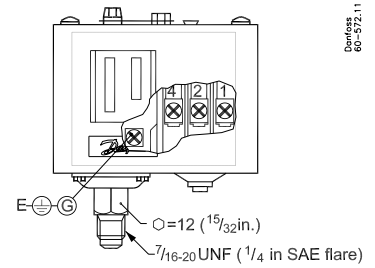

Connections for KP 1A, KP 5A, KP 6AS

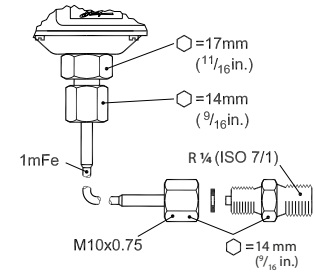

Mounting

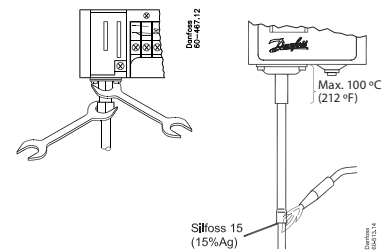

Test pressure (P_{test}) PS/MWP

P_{test}max.:
 KP 1, KP 2: 20 bar p_e (285 psig)
 KP 2: 12 bar p_e (174 psig)
 KP 5, KP 7: 35 bar p_e (510 psig)
 KP 6: 46,5 bar p_e (675 psig)

Type	Regulation range	PS/MWP
KP 1	-0.2 – 7.5 bar	245 psig / 17 bar
KP 1, reset	-0.9 – 7.0 bar	245 psig / 17 bar
KP 1 W	0.5 – 3.0 bar	245 psig / 17 bar
KP 2	-0.2 – 5.0 bar	245 psig / 17 bar
KP 2	-0.2 – 3.5 bar	145 psig / 10 bar
KP 5	8 – 32 bar	510 psig / 35 bar
KP 6	8 – 42 bar	675 psig / 46,5 bar
KP 7	8 – 32 bar	510 psig / 35 bar

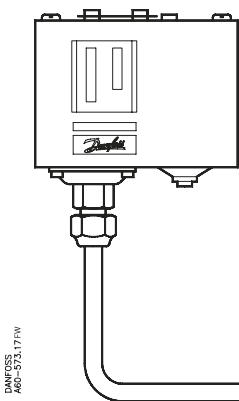

PS/MWP
(Maximum Working Pressure)

Enclosure

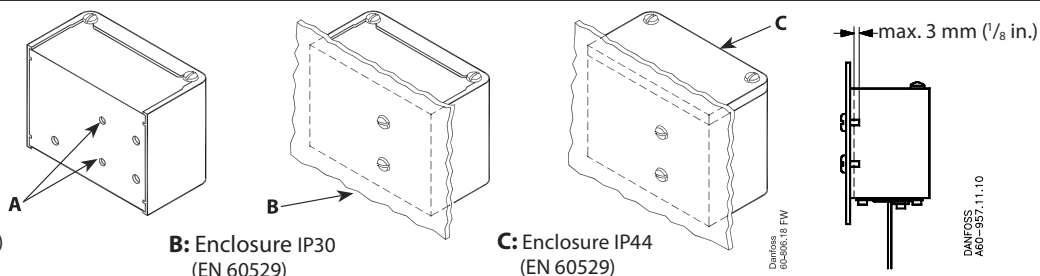

A: 8 – 32 UNC (M4)

B: Enclosure IP30 (EN 60529)

C: Enclosure IP44 (EN 60529)



CAUTION:

Disconnect power supply before wiring connections are made or service to avoid possible electrical shock or damage to equipment. Do never touch live parts with your fingers or with any tool.

Contact 1-4 opens on pressure drop

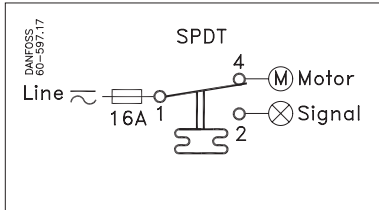

KP 1, KP 2

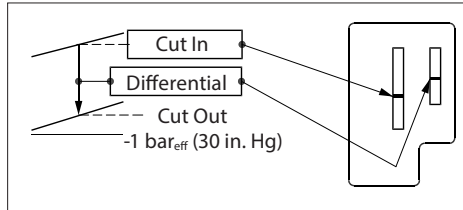

AC 1: 16 A	400 V a.c.	DC 13
AC 3: 16 A		12 W
AC 15: 10 A		220 V

Short circuit protection:
Fuse 16 Amp.

Contact 1-4 opens on pressure drop

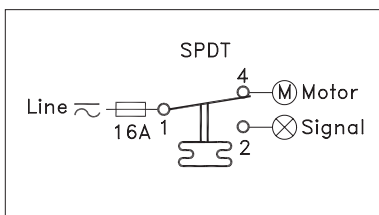

KP 1W, KP 1 manual reset

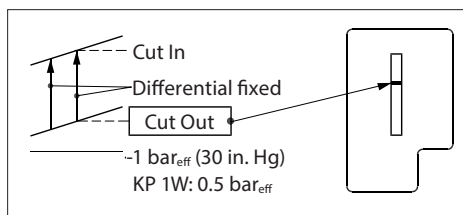

When used acc. to UL regulations

UL US LISTED Listed refrigeration controller 61B5

Voltage	AC DC	FL	LR	Resist. load	Pilot duty
		A	A		
240	—	8	48	8 A	3A
120	—	16	96	16 A	
—	240	—	—	—	12 W

Use copper wire only
Tightening torque 20 lb. in.

Contact 1-2 opens on pressure rise

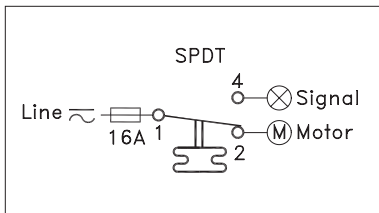

KP 5, KP 5A, KP 6, KP 6A, KP 7

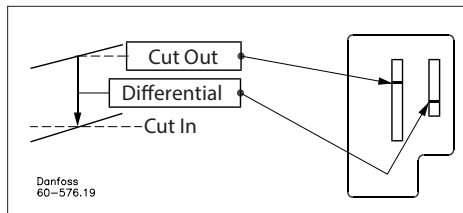

Manual trip function

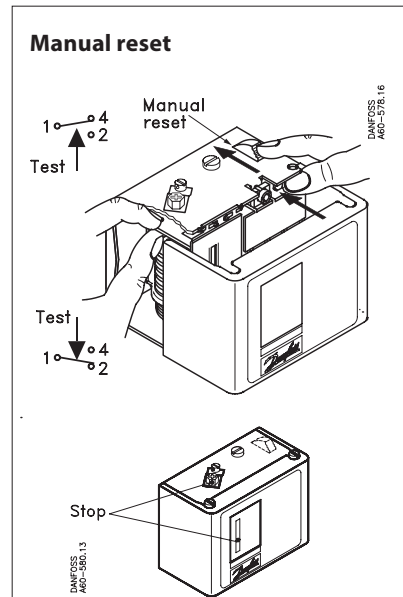
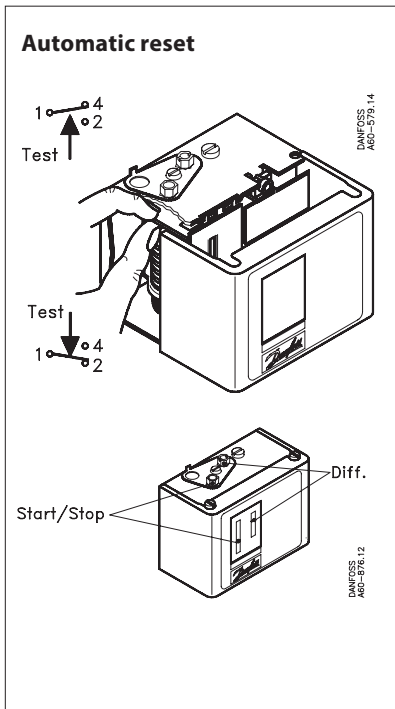

Type	Differential
KP 1, KP 1A	0.7 bar (10 psi)
KP 5, KP 5A	3 bar (43 psi)
KP 6B, KP 6S, KP 6AB, KP 6AS, KP 7B, KP 7S	4 bar (58 psi)

Note:
use FINGERS ONLY!
(Do NOT use screwdriver)

Adjustment

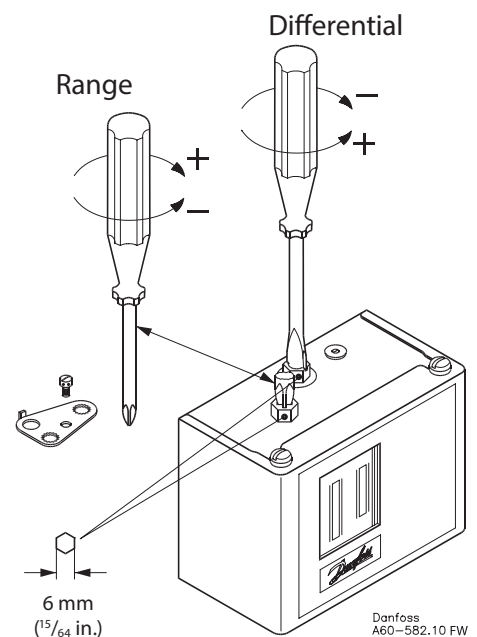



CAUTION:

Only for selected A2L refrigerants: R455A, R454C, R1234yf, R1234yz, R1234ze

For complete list of approved A2L refrigerants, go to <http://products.danfoss.com/all-products/>

Electrical rating

AC-3: 16 A / 250 V AC

AC-15: 10 A / 250 V AC

Voltage	Current range	Power factor (cos phi)	Frequency
250V AC	≤ 4.0 A	PF ≥ 0,400	50Hz/60Hz
250V AC	> 4.0 to 6.0 A	PF ≥ 0,594	50Hz/60Hz
250V AC	> 6.0 to 16,0 A	PF ≥ 0,780	50Hz/60Hz

IMPORTANT NOTICE



Safety requirements

1. KP pressure switches shall only be employed in the units/systems which comply with the requirements for charge limits and requirements for avoiding ignition sources of IEC 60335-2-24, IEC 60335-2-40, IEC 60335-2-89, ISO 5149, EN378-1 or equivalent.
2. Applying the overload on the KPs must be prevented. If by any chance it was damaged, the system / unit shall be stopped and KP shall be replaced as necessary.
3. Electrostatic discharge protection and Electrical leakage protection shall be surely implemented by grounding or other measures.
4. Only trained personnel are authorized to handle flammable refrigerants systems and may do the installation, maintenance and exchange of the switch by using appropriate tools.
5. It is recommended to regularly check the function of KP switch.
6. The KP pressure switches shall be used as built-in devices that cannot be accessible from outside and protected against mechanical impact.
7. The KPs shall be installed in water free environment. In addition, protection of the KP switches against corrosion shall be taken into consideration when using them in corrosive environment.
8. Cables shall not be in contact with sharp edges. The cables shall be connected with adequate stress relieve in order to prevent that pulling forces can be carried thorough the cable to the terminal.
9. In the event of pressure pulsation in the system, where switch is connected, these must be effectively dumped to prevent failure of the bellows. The cycle frequency of KP switch shall be kept as low as possible.
10. The KP switches shall not be installed in places where high level of vibration is present.

Disclaimer

The user is responsible for ensuring that third parties also comply with this Notice, e.g. in case that the KP switches are supplied to third parties, and e.g. that all installation guides are available with the KP switches during installation. It is required that all conditions of this guide are being met and secured when using KP pressure switches.

Danfoss shall not be responsible for any kind of direct and indirect or consequential damage or loss, including, but not limited to, loss of property, production, loss of profit, human injury arising out of the explosion or fire caused by the flammable nature of refrigerant.