



Data sheet

2 - way seated valve (PN 16)

VMA - external thread

Description



VMA is 2-way seated valve primarily for use in district heating systems.

It can be combined with:

- ABV thermohydraulic actuators and
- VMA DN 15 can additionally be combined with self-acting thermostatic actuators RAVI, RAVK and RAVV

All sizes have external thread for flat packing (DIN 7603).

Main data:

- DN 15
- k_{vs} 0,25 - 2,5 m³/h
- PN 16
- Temperature:
 - Circulation water / glycolic water up to 30%: 2 ... 130 °C
- Connections:
 - Ext. thread (weld-on and thread tailpieces)

Ordering

Example:
2-way seated valve, DN 15; k_{vs} 1,6;
PN 16; t_{max} 130 °C; ext. thread

- 1x VMA DN 15 valve
Code No: **065F2034**

- Option:
- 1x Weld-on tailpieces
Code No: **003H6908**

VMA valve

Picture	DN (mm)	k_{vs} (m ³ /h)	Connection		Code No.
	15	0,25	Cylindrical external thread acc. to ISO 228/1	G 3/4 A	065F2030
		0,4			065F2031
		0,63			065F2032
		1,0			065F2033
		1,6			065F2034
		2,5			065F2035

Accessories

Picture	Type designations	DN	Connection		Code No.
	Weld-on tailpieces	15	-		003H6908
	External thread tailpieces	15	Conical ext. thread acc. to EN 10226-1	R 1/2	003H6902

Service kits

Picture	Type designations	Code No.
	Valve stuffing box	065F0006¹⁾

¹⁾ The products can only be ordered in multiple packing containing 10 pieces each

Technical data

Valve

Nominal diameter	DN	15					
k_{vs} value	m ³ /h	0,25	0,4	0,63	1,0	1,6	2,5
Stroke	mm	3					
Control ratio		1:50					
Control characteristic		Approximately linear					
Cavitation factor z		≥ 0.5					
Leakage acc. to standard IEC 534		0,05%					
Nominal pressure	PN	16					
Medium		Circulation water / glycolic water up to 30%					
Medium pH		Min. 7, max. 10					
Medium temperature	°C	2 ... 130					
Connections	valve	Ext. thread					
	tailpieces	Weld-on and external thread					
Materials							
Valve body		Dezincing free brass					
Valve seat		Stainless steel 18/8, mat. No. 1.4305, DIN 17440, SS 14.23.46					
Valve cone		EPDM					
Spindle		Dezincing free brass					
Valve insert		Dezincing free brass					
Valve stuffing box		Dezincing free brass					

Max. differential pressure

Nominal diameter	DN	15					
k_{vs} value	m ³ /h	0,25	0,4	0,63	1,0	1,6	2,5
RAVI / RAVV	bar	5,0	5,0	2,0	2,0	2,0	1,0
RAVK		3,0	3,0	1,5	1,5	1,5	0,5
ABV		7,0	7,0	7,0	7,0	7,0	4,0

Application principle

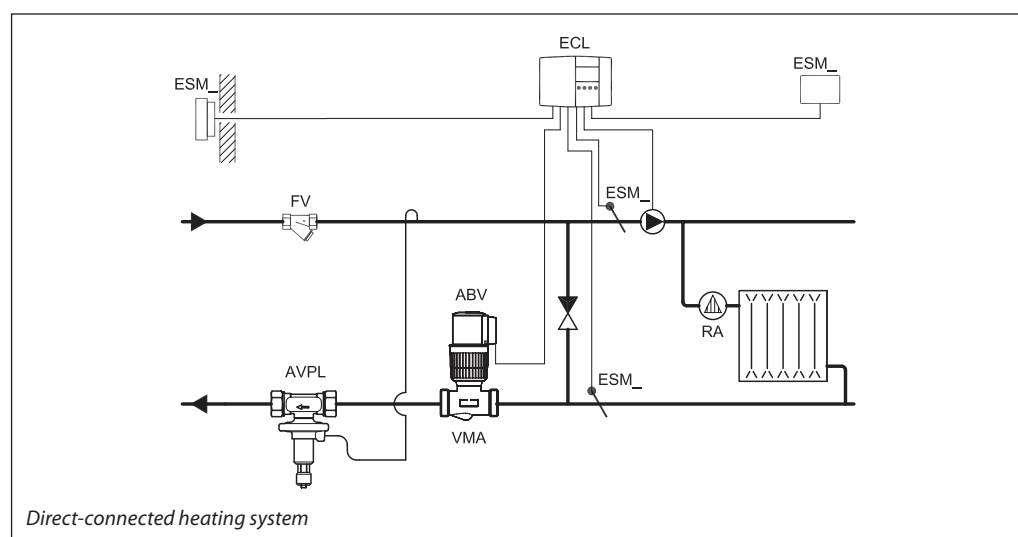

Sizing

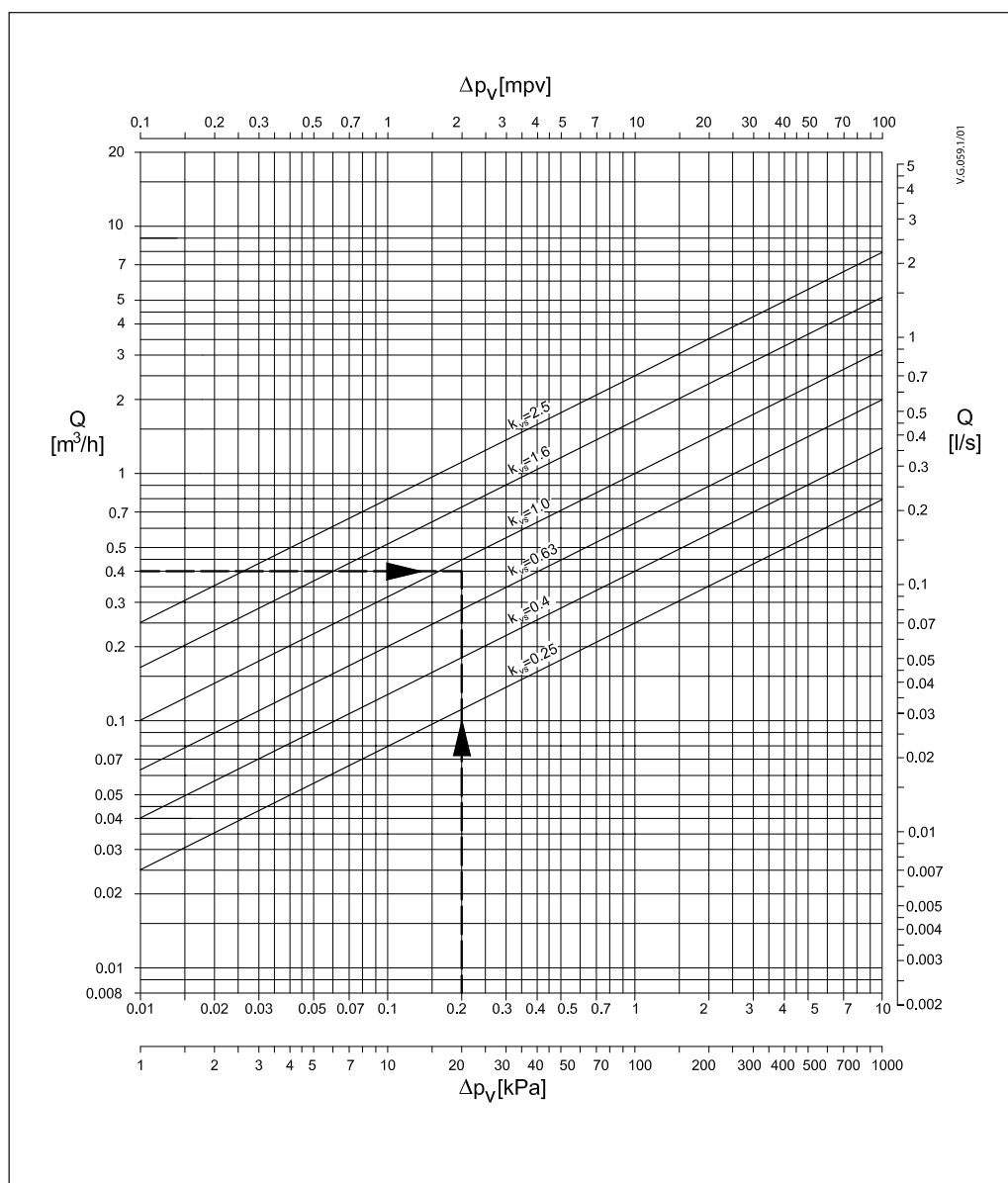

Given data:

$$P_{max} = 9,3 \text{ kW}$$

$$\Delta t = 20 \text{ K}$$

$$\Delta p_V = 0,2 \text{ bar}$$

P_{max} - heating power (kW)

Δt - temperature difference (K)

Δp_V - differential pressure across the valve

Maximum flow Q_{max} (m^3/h) through the valve is calculated according to formula:

$$Q_{max} = \frac{P_{max} \times 0,86}{\Delta t} = \frac{9,3 \times 0,86}{20}$$

$$Q_{max} = 0,4 \text{ m}^3/h$$

k_V value is calculated according to formula:

$$k_V = \frac{Q_{max}}{\sqrt{\Delta p_V}} = \frac{0,4}{\sqrt{0,2}}$$

$$k_V = 0,89 \text{ m}^3/h$$

Chosen $k_{VS} = 1,0 \text{ m}^3/h$

or read from the sizing diagram by taking a line through Q scale ($0,4 \text{ m}^3/h$) and Δp_V scale ($0,2 \text{ bar}$) to intersect k_V -scale at $0,89 \text{ m}^3/h$

Chosen $k_{VS} = 1,0 \text{ m}^3/h$

Solution:

The example selects ext. thread seated valve VMA DN 15, k_{VS} value 1,0

Dimensions

