



Installation guide

Multi Ejector

type CTM 1 - CTM 2

English

032R9798



032R9798



Refrigerant: R744 with oil	Max. Working Pressure: 140 bar / 2031 psi	Media temp. range: -10 °C – +50 °C / 14 °F – 122 °F
Ambient temp. range: -10 °C – +50 °C / 14 °F – 122 °F		Max. OPD: 90 bar / 1305 psi Min. OPD: 0.1 bar / 1.45 psi

Connector positions

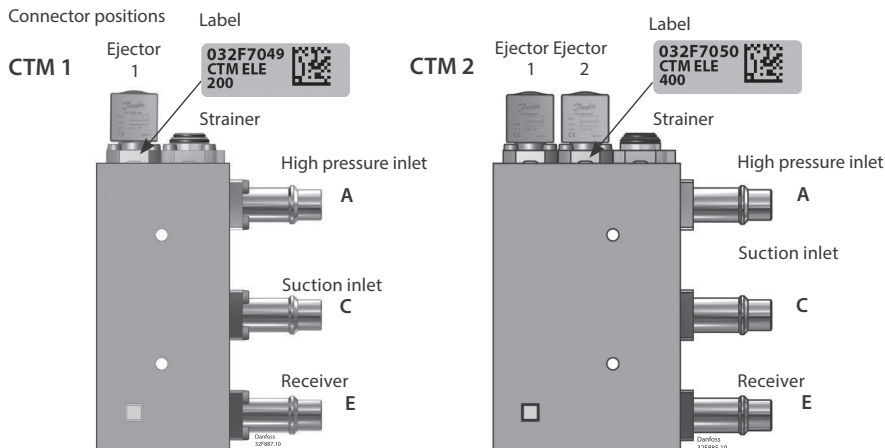

WARNING!

The **CTM** Multi Ejector valve is approved for use only with Danfoss controller type **AK-PC 78x, AK-CC 550A or AK-CC 750A and AK-SM 8xx**.

DISCLAIMER

Danfoss expressly disclaims, and any responsibility or liability, whether based on contract, breach of warranty, tort, statute or otherwise, shall be excluded, if the **CTM** Multi Ejector valve is used with any controller other than a Danfoss controller type **AK-PC 78x, AK-CC 550A or AK-CC 750A and AK-SM 8xx**.

For further information on AK-PC, please see separate document.

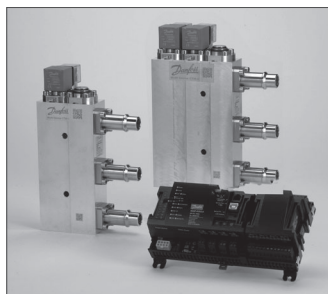

WARNING!

- Do not disassemble / assemble the parts unnecessarily to avoid risk of breaking the O-ring, dirt in the valve etc.
- Avoid high mechanical stress in connection with tube mounting / welding.
- Do not remove connectors during welding / brazing.

General installation

- Always place the ejector with the coils upwards so the check valve inside can use gravity to close.
- Coils available in 110 -120V AC and 230V AC, 50/60Hz.
- It is recommended to place shut-off valves on all 3 connections.
- Evacuating the ejector is recommended to do on the outlet and on the high pressure side.
- Pressurizing the ejector should be done from the suction side first (Suction inlet C).
- It is recommended to install ejector after suction filter (Suction inlet C).

Mounting: With coils upwards

CTM Multi Ejector needs to be fixed to the rack frame using 2 holes in the aluminum block do avoid stress on the connectors

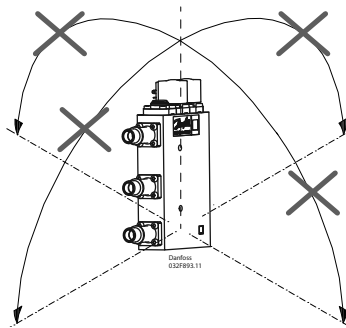

Brazing

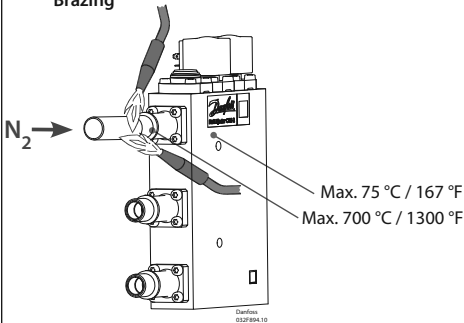

Recommendation for brazing

Recommendation: brazing nozzle 4 - 6 mm ($\frac{5}{32}$ in - $\frac{15}{64}$ in)
Materials used for brazing:

- Flux: Metalli tenacity No. 5 Powder or Braze Tec special h paste.
- Filler: Silver-Flo 55 (BS:AG 14/ DIN L-Ag55 Sn) or Silver-Flo 56 (AWS B Ag-7).

Welding

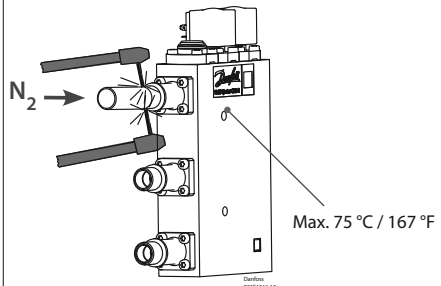

Recommendation for TIG welding

- Power approximately 60 A.
- Use Shield gas charge - Argon.
- Material for welding - approximately 2 mm thick stainless steel alloy.



Warning: Filler metals containing Phosphor i.e. BS: CP 1/ DIN L-Ag 15P or BS: CP 3/ DIN L-Ag P7 must not be used.

Coil

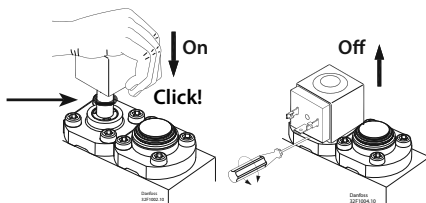

Warning
Be sure that the O-ring is in place.

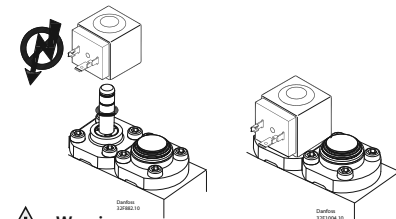

Warning
Never switch on power to the coil when it is dismantled from the valve. There is a danger the coil may be damaged and a risk of injuries and burns.

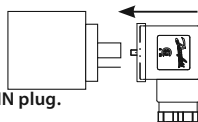

Mounting DIN plug / LED DIN plug.

Armature tubes are sensitive and have to be protected during the installation:

- do not damage the armature tubes with strokes or forces
- do not lift or handle the block by lifting the armature tubes etc.
- avoid pull-forces on the wires connected to the coils

Starting up /Operation:

Opening sequence:

- 1 - connector A
- 2 - connector C
- 3 - connector E

Follow the opening sequence to avoid too high NRV differential pressure.



Starting up the system: open all connection ball valves slowly (avoiding liquid hammer that can damage internal check valve (NRV) and build-in strainer).

It is mandatory to clean the strainer after 2 days of running the system. O-rings needs to be replaced with the two new ones placed on the strainer top. Removed O-rings to be placed on the strainer top and reused after return to initial shape during next strainer maintenance. Strainer cleanliness is important for proper operation of Multi Ejector and the cleaning shall be repeated if necessary every 2-3 weeks to remove the dirt circulating in the system.

Service

Mounting and service of ejectors

Ejectors with the highest capacities (longest ejectors) must be placed closest to the suction connector C.

A: Inlet connector

Gas cooler outlet - Ball valve - inlet connector
Combi brazing 7/8 inch ODF - weld 3/4 inch (EN10220)

C: Suction connector

MT evaporator outlet - Ball valve - suction connector
Combi brazing 7/8 inch ODF - weld 3/4 inch (EN10220)

E: Outlet connector

Outlet connector - Ball valve - Receiver
Combi brazing 7/8 inch ODF - weld 3/4 inch (EN10220)

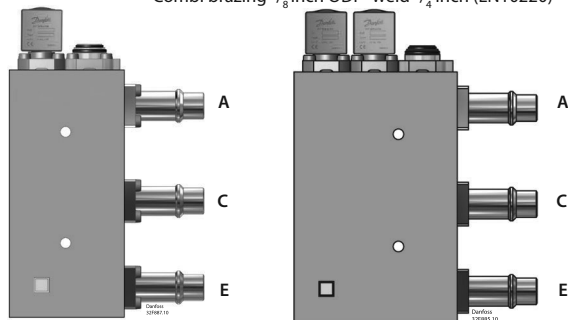

Warning:

Do not disassemble / assemble the parts unnecessarily to avoid risk of breaking the O-ring, dirt in the valve etc.

Insulation of Multi Ejector

Requirements for materials used for insulation:

- has to be based on a synthetic rubber base or ex Polyurethane
- water vapor diffusion resistance number $\mu \leq 7000$

- thermal conductivity $\leq 0,033$ W/(m·K)
 - insulations material thickness ≥ 5 mm
 - for use at low temperature -10°C or lower
 - for use at high temperature $+50^{\circ}\text{C}$ or higher
 - glue or adhesive made of Poly chloroprene or it is Silicone type
- Do not insulate the coils of Multi Ejector

Exchange of connectors and pressure transmitters

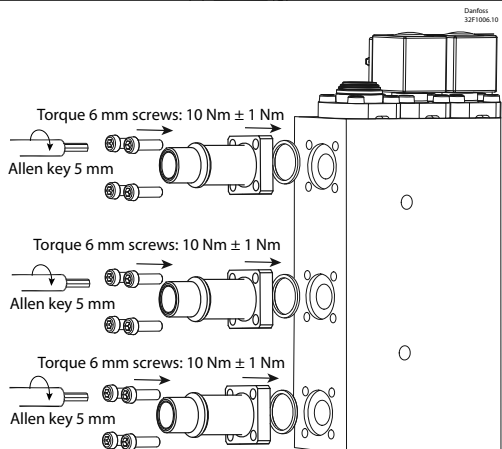

Tightening sequence

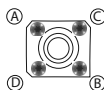

Service

Service on strainer

= compressor oil

Remove strainer from valve body

1 Allen key 5 mm

2

3

4 5 mm allen key Torque 6 Nm ± 1

5

6 5 mm allen key Torque 6 Nm ± 1

7

8 Allen key 5 mm Torque 10 Nm ± 1

Oil O-rings and place strainer in valve

Assemble strainer

Clean or replace strainer and replace O-ring

Dismount strainer

Mount the strainer with screws

Tightening sequence

Service on ejector

1 Allen key 5 mm

2

3

Oil O-rings and place ejector

Replace complete ejector

Mount the ejector with screws

Tightening sequence