

Data sheet

Electric Regulating Valve

Type KVS



KVS is a series of electronic suction modulating valves for AC transport and refrigeration applications.

Accurate temperature or pressure control is obtained by modulating the refrigerant flow in the evaporator with a current or voltage driver.

With an EKC 368 controller (current driver) and an AKS sensor placed in the media to be controlled, an accuracy better than $\pm 0.5K$ can be obtained.

The balanced design provides bi-flow operation as well as solenoid shut-off function in both flow directions at MOPD 33 bar (478 psig).

Features

- Biflow.
- High resolution for precise control.
- Wide range for all common refrigerants R22, R134a, R404A, R407A, R407C, R407F, R422B, R422D, R438A, R448A, R449A, R450A, R452A, R507, R513A, R410A, R1234ze and other refrigerants
- Balanced port design (KVS 42).
- Solenoid tight shut-off.
- Low power consumption.
- Corrosion resistant design external as well as internal.
- Cable and connector assemblies as accessories.
- For manual operation and service of KVS valves an AST-g service driver is available. For further information please contact Danfoss (Commercial Refrigeration & Air Conditioning Controls).

ЮГОВ - Проект

інженерно-виробниче підприємство

Офіційний дистриб'ютор
Danfoss в Україні

ugov.ua

Technical data

Parameter	KVS 15	KVS 42
Compatible refrigerants	R22, R134a, R404A, R407A, R407C, R407F, R422B, R422D, R438A, R448A, R449A, R450A, R452A, R507, R513A, R410A, R1234ze and other refrigerants	R22, R134a, R404A, R407A, R407C, R407F, R422B, R422D, R438A, R448A, R449A, R450A, R452A, R507, R513A, R410A, R1234ze and other refrigerants
Refrigerant oil	All mineral and ester oils	All mineral and ester oils
CE marking	No	Yes
MOPD	33 bar / 478.6 psig	33 bar / 478 psig
Max. working pressure	45.5 bar / 660 psig	34 bar / 493 psig
Inlet fluid temperature	-40 to +65 °C / -40 to +149 °F	-40 to +65 °C / -40 to +149 °F
Ambient temperature	-40 to +60 °C / -40 to +140 °F	-40 to +60 °C / -40 to +140 °F
Total stroke	13 mm / 0.5 inch	17.2 mm / 0.68 inch
Motor enclosure	IP 67	IP 67
Material of Construction	Body and AST Encloser: Brass Connector: Copper	Body and AST Encloser: Brass Connector: Copper

Electrical data

Parameter	KVS 15 and KVS 42
Stepper motor type	Bi-polar - permanent magnet
Step mode	2 phase full step
Phase resistance	52 Ω ±10%
Phase inductance	85 mH
Holding current	Constant voltage drive: Depends on application. Chopper drive: full current allowed (100% duty cycle)
Step angle	7.5° (motor), 0.9° (lead screw), Gearing ration 8.5:1. (38/13)2:1
Nominal voltage	Constant voltage drive: 12 V DC -4% – 15%, 150 steps/sec.
Phase current	(Using chopper drive) 100 mA RMS -4% +15%,
Max. total power	Voltage / current drive: 5.5 / 1.3 W (UL: NEC class 2)
Step rate	Constant voltage drive: 150 steps/sec. Chopper current drive: 0 – 300 steps/sec. 300 recommended
Total steps	KVS 15: 2625 [+160 / -0] steps KVS 42: 3810 [+160 / -0] steps
Full travel time	KVS 15: 17 / 8.5 sec. (voltage / current) KVS 42: 25.4 / 12.7 sec. (voltage / current)
Lifting height	KVS 15: 13 mm / 0.5 inch KVS 42: 17.2 mm / 0.68 in
Reference position	Overdriving against the full close position
Electrical connection	M12 connector

Compatible controller / driver	EKC 368 / EKD 316 or EKD 316C
---------------------------------------	-------------------------------

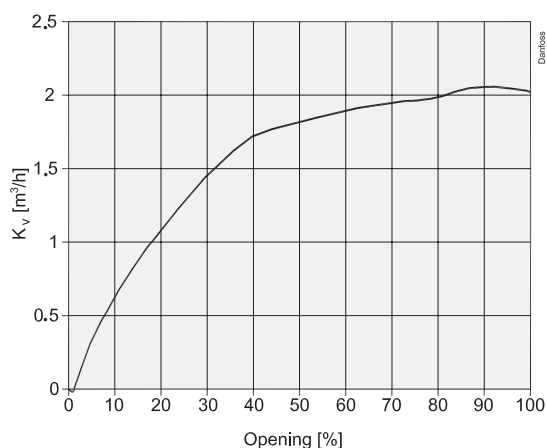
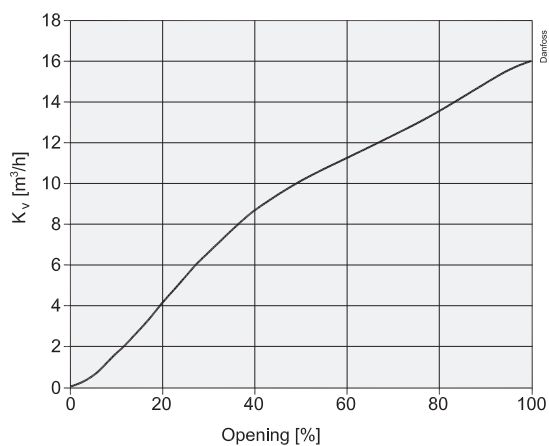
Flow curves
KVS 15 Capacity Curve

KVS 42 Capacity Curve

Data sheet | Electric regulating valve type KVS 15 – KVS 42

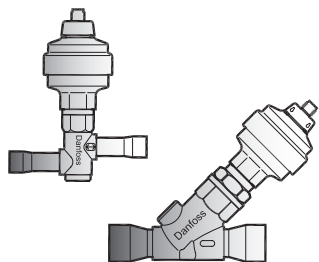
Ordering



KVS valves in single pack



Type	Rated capacity ¹⁾						Connections		Code no. single pack
	R22		R134a		R404A/R507		ODF		
	kW	TR	kW	TR	kW	TR	mm	in.	
KVS 15	5.15	1.31	3.78	0.94	4.58	1.07	16	5/8	034G4252
							22	7/8	034G4253
KVS 42	40.4	11.4	29.3	8.3	35.3	10.0	22	7/8	034G2858
							28	1 1/8	034G2850
							35	1 3/8	034G2851
							-	1 5/8	034G2852

¹⁾ Rated capacity is the valve capacity at evaporating temperature $t_e = -10^\circ\text{C}$ (14°F), condensing temperature $t_c = +25^\circ\text{C}$ (77°F) and pressure drop across valve $\Delta p = 0.2$ bar (2.9 psig).

Accessories: M12 Female Connector Cable

Spare parts

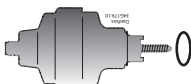
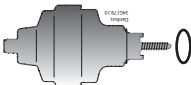
Actuator with integrated M12 connection

Items	Description	Quantity [pcs]	Code no.
	Actuator with integrated M12 with Ceramic bearing (incl. metal gasket) for KVS 15	1	034G2088
	Actuator with integrated M12 with ceramic bearing (incl. metal gasket) for KVS 42	1	034G2087
	Metal Gasket	1	034G2344

Accessories:

M12 angle cable

M12 angle female connector is intended for use with a standard M12 male connector, available on stepper motor valves.

This cable is designed to offer high flexibility and small outer diameters with tensile strength. The angle way M12 cable consist of paired, twisted wires, which decreases mutual influence between signals transmitted along the cable and reduces influence of external sources of interference. The cables thus provides a higher degree of protection against lost steps compared to other cables.

Approvals



Specification

Jacket	PVC - black
Cable outer sheath	Oil - resistant
Water proof rating	IP 67
Operating temperature range	-40 – +80 °C
Wire type	Twisted pair, cross section 20 AWG / 0.5 mm ²
Cable outer diameter	7.0 mm
Minimum bending radius	10 x cable diameter
Cable combustibility / test	Flame retardant / VW-1 / CSA FT - 1
M12 standard	EN 61076-2-101
Reference standard	UL style 2464 and DIN VDE 0812
LVD directive	73/23/EEC and 93/68/EEC

Ordering

Cable	Cable length (L)	Insulation	Packing format	Code no.
PVC - black	2 m / 6.6 ft	SR-PVC	Single pack	034G7073
	8 m / 26.2 ft	SR-PVC	Single pack	034G7074

Identification

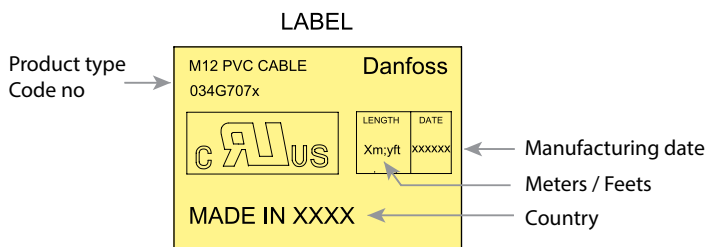

Connections

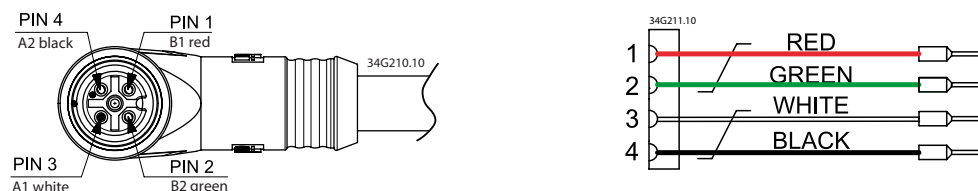

Dimensions

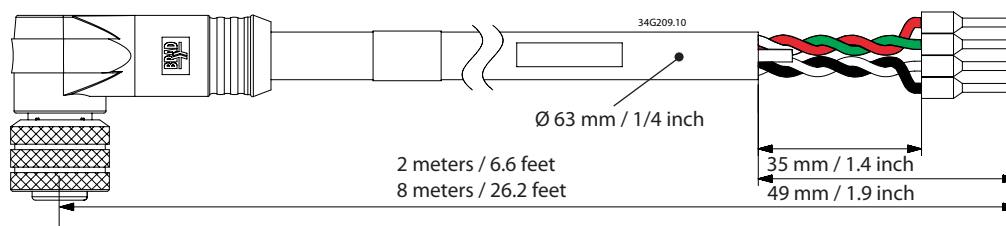

Design

⚠ Note:
Flow direction from A to B
refers the normal flow.

KVS 42

1. M12 Connector
2. Glass seal
3. AST motor housing
4. Stepper motor
5. Bearing
6. Spindle
7. Top nut
8. Valve piston
9. Valve seat
10. Valve cone

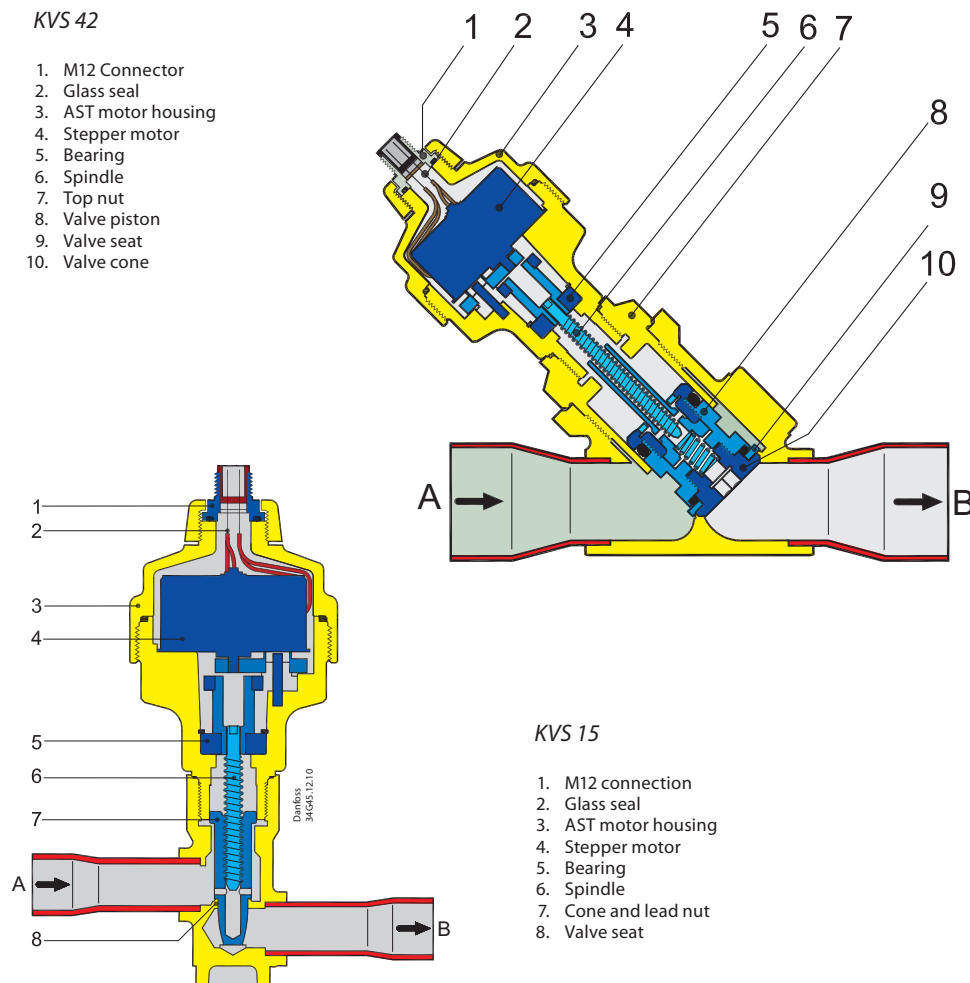

Danfoss
34G103.11.11

KVS 15

1. M12 connection
2. Glass seal
3. AST motor housing
4. Stepper motor
5. Bearing
6. Spindle
7. Cone and lead nut
8. Valve seat

Electrical wiring

⚠ Note:
Electrical check of
stepper motor and
wiring: coil I = 52 ohm
coil II = 52 ohm

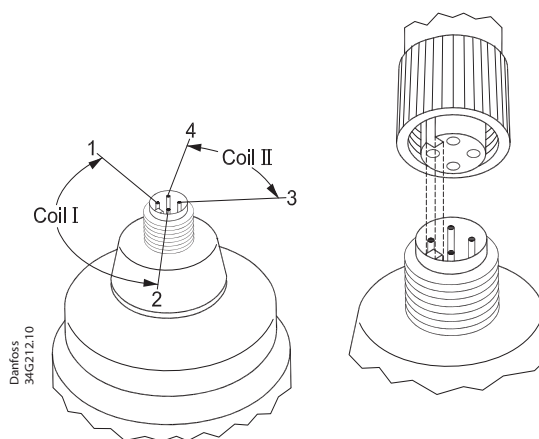

Danfoss
34G212.10

Stepper motor switch sequence

	STEP	Coil I		Coil II		
		Red	Green	White	Black	
↑ CLOSING ↑	1	+	-	+	-	↓ OPENING ↓
	2	+	-	-	+	
	3	-	+	-	+	
	4	-	+	+	-	
	1	+	-	+	-	

If the controller driving the KVS valve is from another manufacturer than Danfoss or a custom design, the following points must be considered in order to overcome potential step loss.

a. To ensure total closing of the valve, the controller should have a function to overdrive the valve in the closing direction. It is recommended to overdrive ten percent of the full step range at appropriate intervals.

b. The amount of lost steps may increase as a function of the amount of changes of the opening degree. Such designed controller should be able to compensate the lost steps after a defined number of changes in opening degree.

Warning:
At power failure the KVS valve will remain in the opening position it has at the moment of power failure, unless a safety device in the form of a battery backup is installed.

Valve application

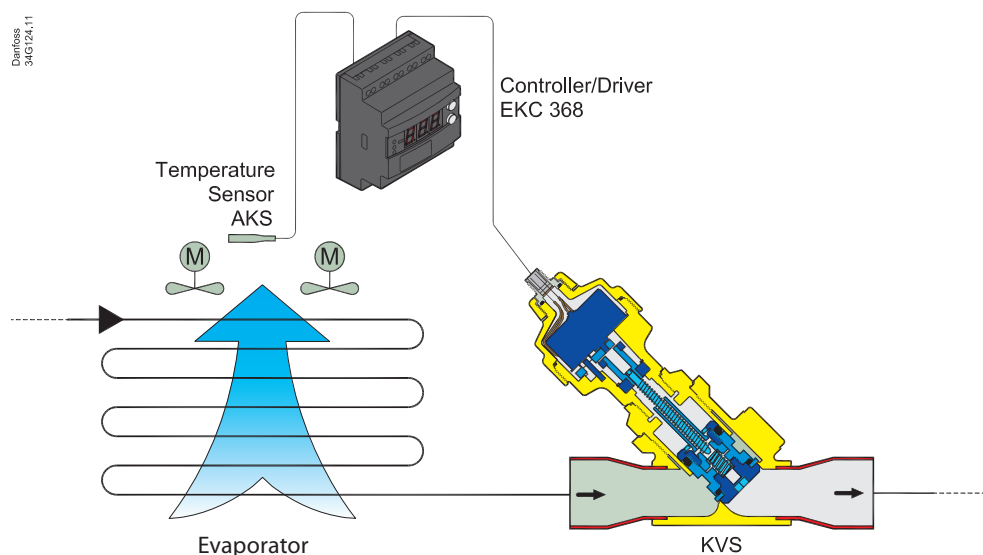

Valve operation

The KVS valves operate modulating by electronically controlled activation of the AST stepper motor. The motor is a type 2-phase bipolar, which stays in position, unless power pulses from a driver initiate the two discrete sets of motor stator windings for rotation in either directions.

The direction of the rotation of the spindle depends on the phase relationship of the power pulses. This is decisive for the travel of the piston.

The motor is operating the spindle, whose rotating movements are transformed into linear motion by the transmission in the cage assembly. The AST motor housing has an integrated M12 connector.

The KVS 42 valves have a pressure slide port respectively exponential cone, combining the best performance qualities at part load conditions as well as providing a zero-resistance at maximum capacity.

The piston design is fully power balanced, giving identical bi-flow performance capabilities and nearby identical maximum capacities.

Closing the valve by overdriving, ensures that the reference number in steps is always correct.

Operating the KVS series requires a controller with either 12 V dc voltage drive (5.5 W) or using chopper drive (100 mA RMS).

Danfoss EKC 368 in an example of a qualified controller.

Note:
Cable length between driver and actuator exceeding 10 m (30 feet) can set off self-induction with reduction in the transmitted power and irregularity in the sequences as consequence.

This may result in loss of steps now and again or more permanent inadequate power supply to the step motor.

The driver circuit as well as the cable specifications are part of this interference.

Please contact Danfoss for further information and possible countermeasures.



Coolselector2®

For easy and precise selection of valve, use Danfoss' CoolSelector2® software. You can find the KVS valves on the group, "Control and regulating valves". You can download it from <http://coolselector.danfoss.com>

Valve sizing

For optimum performance, it is important to take into consideration all system conditions and requirements. Selection is also dependent on an acceptable pressure drop across the valve. The following information will be needed when sizing a KVS valve:

- Refrigerant
- Evaporator capacity Q_e in kW or TR
- Evaporating temperature t_e in °C or °F
- Liquid temperature ahead of expansion valve t_l in °C or °F
- Max. acceptable pressure drop in the KVS valve in bar or psig
- Connection size

Valve selection Example

In valve selection it may be necessary to apply a correction factor to the actual evaporator capacity. This correction is required when system conditions are different than table conditions. Selection also depends on having an acceptable pressure drop across the valve. The following example illustrates correct sizing.

- Refrigerant: R 404A
- Evaporator capacity: $Q_e = 20 \text{ kW} / 5.7 \text{ TR}$
- Evaporating temperature: $t_e = -10^\circ\text{C} \sim 3.4 \text{ bar} / 14^\circ\text{F} \sim 49.3 \text{ psig}$
- Liquid temperature ahead of expansion valve: $t_l = 25^\circ\text{C} / 77^\circ\text{F}$
- Max. pressure drop in the valve: $\Delta p = 0.2 \text{ bar} / 2.9 \text{ psig}$
- Connection type: Solder
- Connection size: $1\frac{1}{8} \text{ in.}$

Step 1

Determine the correction factor for liquid temperature t_l ahead of expansion valve.

From the correction factors table (see below) a liquid temperature of $25^\circ\text{C} / 100^\circ\text{F}$, R404A corresponds to a factor of 1.0.

Correction factors for liquid temperature t_l

t_l °C	10	15	20	25	30	35	40	45	50
R134a	0.88	0.92	0.96	1.0	1.05	1.10	1.16	1.23	1.31
R22	0.90	0.93	0.96	1.0	1.05	1.10	1.13	1.18	1.24
R404A / R507	0.84	0.89	0.94	1.0	1.07	1.16	1.26	1.40	1.57
R407C	0.88	0.91	0.95	1.0	1.05	1.11	1.18	1.26	1.35

Step 2

Corrected evaporator capacity is $Q_e = 20 \times 1.0 = 20 \text{ kW} / 5.7 \times 1.0 = 5.7 \text{ TR}$

Step 3

Now select the appropriate capacity table, R404A, and choose the column for an evaporating temperature of $t_e = -10^\circ\text{C} / 14^\circ\text{F}$.

KVS 42 delivers $33.32 \text{ kW} / 9.5 \text{ TR}$ at a $0.2 \text{ bar} / 2.9 \text{ psig}$ pressure drop across the valve.

Using the corrected evaporator capacity, select a valve that provides an equivalent or greater capacity at an acceptable pressure drop across the valve of $0.2 \text{ bar} / 2.9 \text{ psig}$.

Based on the required connection size of $1\frac{1}{8} \text{ in.}$, the KVS 42 is the proper selection for this example.

Rated Capacity (kW)

SI units

	t_e	Rated capacity [kW]											
		KVS 15						KVS 42					
		Pressure drop Δp [bar]						Pressure drop Δp [bar]					
		[°C]	0.05	0.1	0.2	0.3	0.5	0.7	0.05	0.1	0.2	0.3	0.5
R404A	10	3.30	4.65	6.52	7.93	10.1	11.7	25.5	36.0	50.5	61.4	78.1	91.0
	0	2.71	3.81	5.34	6.47	8.18	9.46	21.0	29.6	41.4	50.1	63.7	73.3
	-10	2.28	3.09	4.38	5.19	6.49	7.43	17.8	23.9	33.3	40.2	50.3	57.5
	-20	1.75	2.45	3.39	4.06	5.00	5.61	13.6	19.0	26.3	31.5	38.7	43.5
	-30	1.37	1.91	2.60	3.08	3.67	3.97	10.6	14.8	20.2	23.9	28.5	30.8
	-40	1.04	1.44	1.92	2.22	2.49	2.50	8.08	11.1	14.9	17.2	19.3	19.4

Step 4

KVS 42, $1\frac{1}{8} \text{ in.}$:
Single pack code no. 034G2850

SI units

Correction factor table

t _i °C	10	15	20	25	30	35	40	45	50
R134a	0.88	0.92	0.96	1.0	1.05	1.10	1.16	1.23	1.31
R22	0.90	0.93	0.96	1.0	1.05	1.10	1.13	1.18	1.24
R404A / R507	0.84	0.89	0.94	1.0	1.07	1.16	1.26	1.40	1.57
R407C	0.88	0.91	0.95	1.0	1.05	1.11	1.18	1.26	1.35

Capacities

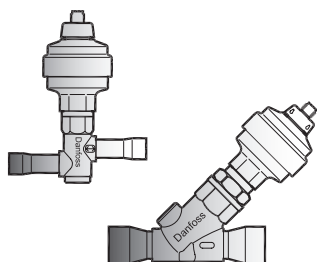

Rated Capacity (kW)

	t _e [°C]	KVS15						KVS 42					
		Pressure drop Δp [bar]						Pressure drop Δp [bar]					
		0.05	0.1	0.2	0.3	0.5	0.7	0.05	0.1	0.2	0.3	0.5	0.7
R134a	10	2.94	4.12	5.73	6.91	8.62	9.84	22.75	31.92	44.43	53.54	66.82	76.28
	0	2.38	3.33	4.60	5.50	6.75	7.56	18.46	25.81	35.67	42.65	52.32	58.56
	-10	1.90	2.64	3.61	4.26	5.07	5.46	14.72	20.47	27.96	33.00	39.27	42.29
	-20	1.48	2.05	2.74	3.15	3.52	3.55 ¹⁾	11.50	15.85	21.20	24.42	27.30	27.47 ¹⁾
R404A	10	3.30	4.65	6.52	7.93	10.08	11.74	25.54	35.99	50.53	61.43	78.11	91.00
	0	2.71	3.81	5.34	6.47	8.18	9.46	21.01	29.56	41.37	50.14	63.35	73.30
	-10	2.20	3.09	4.30	5.19	6.49	7.43	17.03	23.91	33.32	40.20	50.28	57.54
	-20	1.75	2.45	3.39	4.06	5.00	5.61	13.58	19.00	26.29	31.47	38.72	43.47
	-30	1.37	1.91	2.60	3.08	3.67	3.97	10.61	14.76	20.18	23.85	28.47	30.78
R407C	-40	1.04	1.44	1.92	2.22	2.49	2.50 ¹⁾	8.08	11.14	14.91	17.20	19.26	19.39 ¹⁾
	10	3.58	5.04	7.06	8.56	10.84	12.57	27.73	39.04	54.69	66.34	83.98	97.37
	0	2.94	4.14	5.77	6.97	8.74	10.03	22.81	32.05	44.71	54.01	67.74	77.75
	-10	2.39	3.34	4.63	5.55	6.86	7.74	18.48	25.88	35.87	43.03	53.14	59.94
R22	-20	1.90	2.64	3.62	4.29	5.16	5.62	14.70	20.48	28.07	33.26	39.96	43.56
	10	3.74	5.26	7.38	8.96	11.36	13.19	28.95	40.76	57.16	69.40	88.01	102.22
	0	3.14	4.41	6.16	7.45	9.38	10.80	24.30	34.16	47.73	57.74	72.66	83.70
	-10	2.60	3.64	5.06	6.09	7.57	8.60	20.12	28.21	39.21	47.17	58.63	66.60
	-20	2.12	2.96	4.07	4.85	5.90	6.54	16.40	22.90	31.55	37.59	45.75	50.67
-30	1.69	2.35	3.18	3.73	4.36	4.57	13.10	18.18	24.68	28.92	33.79	35.44	
-40	1.32	1.81	2.39	2.71	2.89 ¹⁾	x ¹⁾	10.23	14.02	18.52	20.99	22.37 ¹⁾	x ¹⁾	

* The valves in the capacity table refer to the evaporator capacity and based on liquid temperature t_i=30°C, superheat= sub cooling = 0 K.

* The conditions printed are the most common for the different refrigerants.

Other conditions can be calculated with Danfoss calculation software CoolSelector®

* The pressure drop across the valve is assumed to be the difference between evaporation pressure and suction pressure.

¹⁾ The capacity of vapour flow will not increase for pressure drops above the critical pressure drop.

US units

Correction factor table

t _i °F	50	60	70	80	90	100	110	120
R134a	0.79	0.82	0.86	0.90	0.95	1.0	1.06	1.13
R22	0.82	0.85	0.88	0.92	0.96	1.0	1.05	1.10
R404A / R507	0.71	0.75	0.80	0.85	0.92	1.0	1.10	1.24
R407C	0.78	0.81	0.85	0.89	0.94	1.0	1.07	1.15

Capacities

Rated Capacity (TR)

(TR) = ton of refrigerants

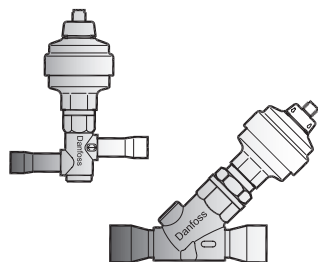

	t _e [°F]	KVS15						KVS 42					
		Pressure drop Δp [psi]						Pressure drop Δp [psi]					
		0.7	1.5	3	5	7	10	0.7	1.5	3	5	7	10
R134a	50	0.86	1.25	1.73	2.19	2.53	2.91	6.65	9.66	13.44	16.96	19.60	22.58
	30	0.68	0.98	1.36	1.69	1.93	2.17	5.28	7.63	10.53	13.12	14.96	16.83
	10	0.53	0.76	1.03	1.26	1.40	1.49	4.10	5.88	7.99	9.74	10.82	11.58
	-5	0.43	0.61	0.82	0.96	1.03	1.03 ¹⁾	3.34	4.74	6.32	7.46	7.95	8.01 ¹⁾
R404A	50	0.98	1.43	2.00	2.56	3.00	3.53	7.59	11.06	15.53	19.84	23.23	27.33
	30	0.79	1.15	1.61	2.04	2.38	2.78	6.12	8.90	12.45	15.83	18.45	21.52
	10	0.63	0.91	1.26	1.59	1.84	2.12	4.85	7.03	9.78	12.34	14.26	16.41
	-5	0.52	0.75	1.04	1.29	1.48	1.67	4.01	5.81	8.02	10.03	11.47	12.97
	-20	0.42	0.61	0.83	1.03	1.15	1.26	3.28	4.72	6.46	7.95	8.94	9.80
-40	0.32	0.45	0.60	0.71	0.76	0.77 ¹⁾	2.44	3.47	4.64	5.50	5.89	5.95 ¹⁾	
R407C	50	1.05	1.53	2.14	2.72	3.18	3.72	8.12	11.82	16.55	21.09	24.62	28.81
	30	0.84	1.23	1.71	2.16	2.50	2.90	6.54	9.50	13.24	16.75	19.40	22.44
	10	0.67	0.96	1.33	1.67	1.91	2.16	5.17	7.47	10.33	12.91	14.77	16.71
	-5	0.55	0.79	1.08	1.33	1.50	1.64	4.26	6.14	8.40	10.34	11.62	12.73
R22	50	1.08	1.58	2.21	2.82	3.30	3.87	8.40	12.24	17.16	21.88	25.58	29.99
	30	0.89	1.30	1.81	2.30	2.67	3.10	6.92	10.06	14.04	17.80	20.68	24.01
	10	0.72	1.05	1.45	1.82	2.10	2.39	5.60	8.11	11.25	14.13	16.24	18.54
	-5	0.61	0.88	1.21	1.50	1.70	1.90	4.72	6.81	9.36	11.62	13.18	14.69
	-20	0.51	0.73	0.99	1.20	1.33	1.42	3.92	5.62	7.64	9.30	10.31	10.99
-40	0.39	0.54	0.72	0.83	0.86 ¹⁾	0.86 ¹⁾	2.98	4.22	5.56	6.43	6.64 ¹⁾	6.64 ¹⁾	

* The valves in the capacity table refer to the evaporator capacity and based on liquid temperature t_e=86°F, superheat= sub cooling = 0 K.

* The conditions printed are the most common for the different refrigerants. Other conditions can be calculated with Danfoss calculation software CoolSelector®

* The pressure drop across the valve is assumed to be the difference between evaporation pressure and suction pressure.

1) The capacity of vapour flow will not increase for pressure drops above the critical pressure drop.

Dimensions and weights

KVS 15

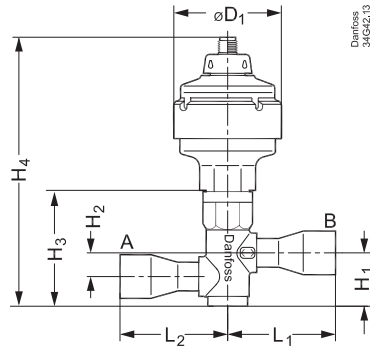

Type	Connections		H ₁		H ₂		H ₃		H ₄		L ₁		L ₂		øD ₁		Weight	
	ODF x ODF (A x B)		[in]	[mm]	[in]	[mm]	[in]	[mm]	[in]	[mm]	[in]	[mm]	[in]	[mm]	[in]	[mm]	[kg]	[lb.]
	[in]	[mm]																
KVS 15	5/8 x 5/8	16 x 16	1.2	30	0.5	13	2.5	64	5.9	159	2.4	60	2.4	60	2.4	60	0.7	1.5
	7/8 x 7/8	22 x 22																

KVS 42

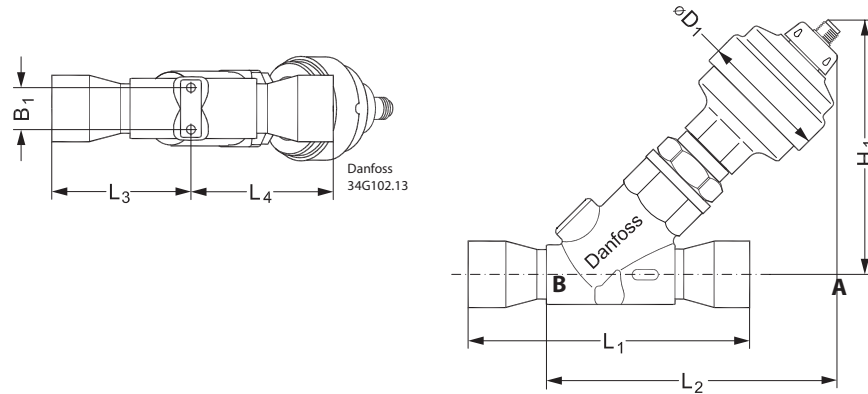

Type	Connections		H ₁		L ₁		L ₂		L ₃		L ₄		øD ₁		B ₁		Weight	
	ODF x ODF (A x B)		[in]	[mm]	[in]	[mm]	[in]	[mm]	[in]	[mm]	[in]	[mm]	[in]	[mm]	[in]	[mm]	[kg]	[lb.]
	[in]	[mm]																
KVS 42	7/8 x 7/8	22 x 22	4.8	120	7.4	188.5	5.6	143	3.7	93	3.8	95.5	2.4	60	0.95	24	1.9	4.2
	1 1/8 x 1 1/8	28 x 28	4.8	120	6.7	168.5	5.6	143.0	3.3	83.0	3.4	85.5	2.4	60	0.95	24	1.9	4.2
	1 3/8 x 1 3/8	35 x 35	4.8	120	7.0	178.5	5.6	143.0	3.5	88.0	3.6	90.5	2.4	60	0.95	24	1.9	4.2
	1 5/8 x 1 5/8	-	4.8	120	7.4	188.5	5.6	143.0	3.7	93.0	3.8	95.5	2.4	60	0.95	24	1.9	4.2

Related products

			<p>Code no. 034G0013</p>
<p>EKD 316 driver</p>	<p>EKC 368 controller</p>	<p>AKS 11 / AKS 12 temperature sensor AKS pressure transmitter</p>	<p>AST-G service driver</p>

Danfoss can accept no responsibility for possible errors in catalogues, brochures and other printed material. Danfoss reserves the right to alter its products without notice. This also applies to products already on order provided that such alterations can be made without consequential changes being necessary in specifications already agreed. All trademarks in this material are property of the respective companies. Danfoss and the Danfoss logotype are trademarks of Danfoss A/S. All rights reserved.