



Installation guide

Electric 3-way valve

Type CTR 20

UK
CA

027R9972

027R9972

Main application: Heat reclaim	Refrigerant: R744 for other refrigerants contact Danfoss	Ambient temperature: Min. -40 °C / -40 °F Max. 60 °C / 140 °F	Fluid temperature: Min. 0 °C / 32 °F Max. 150 °C / 302 °F
Stepper motor type: Bipolar		Max working pressure: 140 Bar / 2030 psig	Total full steps: 6600
Phase Current: 100 mA RMS / 141 mA Peak		Coil resistance: 52 Ohm ±10% (25 °C)	Step rate: 75 stp./sec.



Note!

Valves are delivered in approximately half opened position and is ready for brazing.



Warning!

Do not connect directly to AC / DC power source. Connect valve to appropriate controller/driver only. Do not operate valve while assembling or disassembling.

Flow direction

A.

1 in 2 outs

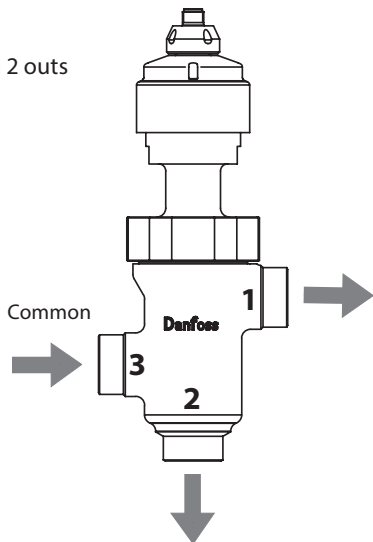

B.

2 in 1 out

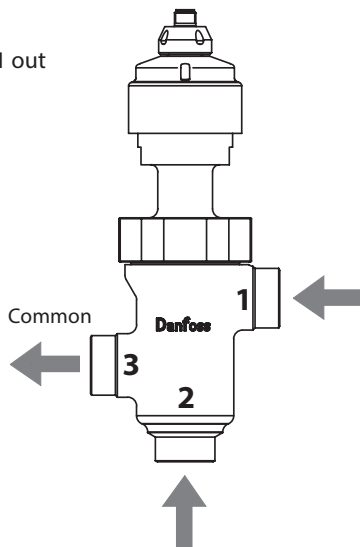

For more information on the product,
please scan the QR code.

Info for UK customers only: Danfoss Ltd. Oxford Road, UB9 4LH Denham, UK

Mounting direction

1

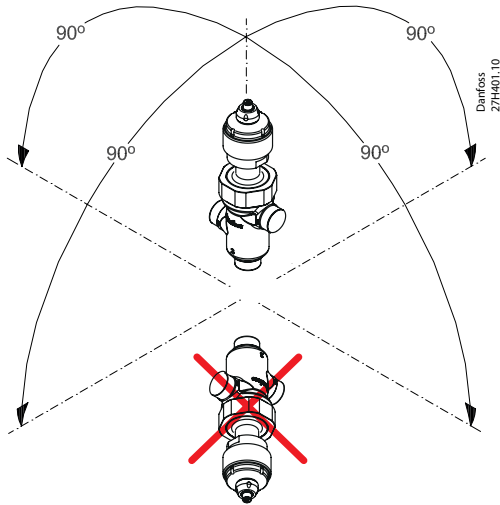

2

- Do not disassemble the valve before brazing or welding.
- the valve must be in middle position by brazing and welding (as it is delivered).

Brazing

3a

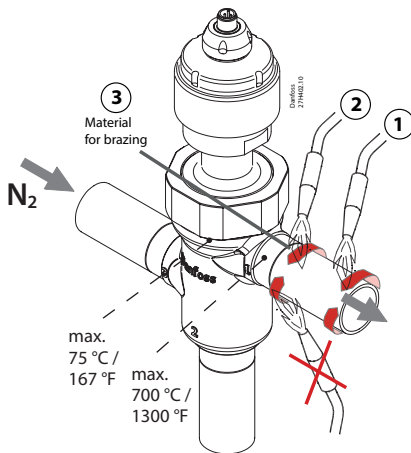

Welding

3b

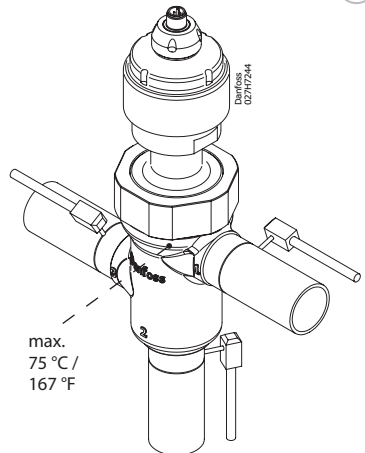

Recommendation: Solder nozzle 4 - 6 mm N (5/32 in - 15/64 in)

Materials used for brazing:

- Flux: Metall tenacity No. 5 Powder or Braze Tec special h paste.
- Filler: Silver-Flo 55 (BS:AG 14/ DIN L-Ag55 Sn) or Silver-Flo 56 (AWS B Ag-7).

Recommendation for TIG welding

- Power approximately 60A.
- Use Shield gas charge - Argon.
- Material for welding - approximately 2 mm thick stainless steel alloy.



Filler metals containing Phosphor i.e. BS: CP 1/ DIN L-Ag 15P or BS: CP 3/ DIN L-Ag P7 must not be used.

Electrical connections

4

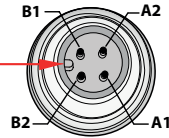
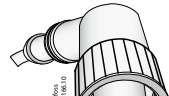
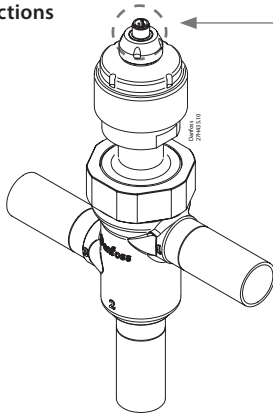

M12 connection on CTR valve

A1 and A2 = coil I
B1 and B2 = coil II



Warning /

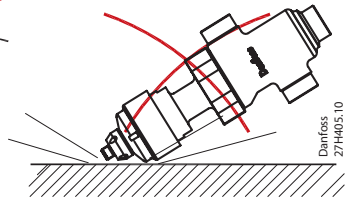
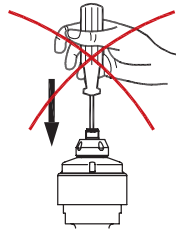
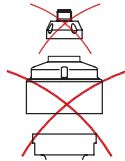
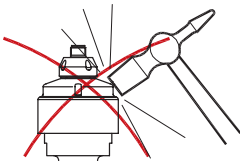

Danfoss
271H40.5.10

For your own notes

Service only

<p>①</p> <p>Spanner: 72 mm / 2.8 in</p> <p>5 X</p> <p>Unskrew the big nut with 5 rotations</p>	<p>②</p> <p>Lift the motor with a screwdriver until it is loose</p>
<p>③</p> <p>Unskrew the big nut fully</p>	<p>④</p> <p>Service kit with 3 O-rings Code no. 027H7248</p> <ul style="list-style-type: none"> 1 Green dot ● 2 Red dot ● 3 No color
<p>⑤</p> <p>Align</p> <p>The "fixing" pin must be placed in the gap</p>	<p>⑥</p> <p>Max. torque: 130 Nm / 95.9 ft-lbf</p>