

ENGINEERING
TOMORROW

Danfoss

Quick Selection Guide
Australia & New Zealand Second Edition

Products and technologies for all
your application needs,
today and **tomorrow**

REFRIGERATION & AIR CONDITIONING

Flow Controls | Electronic Controllers | Compressors | IR Products

Easy

selection of future-
proof solutions and
components.

ЮГОВ - Проект

інженерно-виробниче підприємство

Офіційний дистриб'ютор
Danfoss в Україні



ugov.ua

1300 328 008
customercare.pac@danfoss.com

Coolselector®

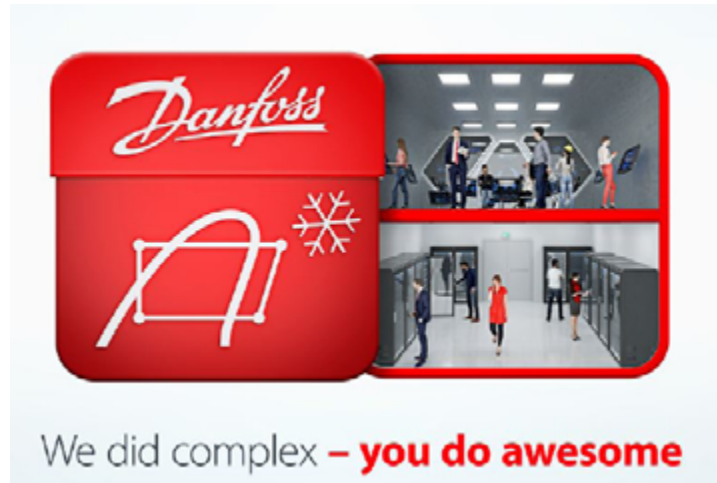

Coolselector2 - Cool romm.csprj

File Options Tools Help About Selections Report Bill of Materials

<p>VALVES AND LINE COMPONENTS</p>	<p>Control and regulating valves</p>	<p>Electronic expansion valve</p>	<p>Filters and stainers</p>
<p>COMPONENTS IN SERIES</p>	<p>Solenoid valves</p>	<p>Thermostatic expansion valve</p>	<p>Filter driers</p>
<p>COMPRESSORS AND CONDENSING UNITS</p>	<p>Check valves</p>	<p>Manual expansion valve</p>	<p>Burnout filters</p>
<p>ELECTRONIC CONTROLS</p>	<p>Stop and shut off valves</p>	<p>Float expansion valve</p>	<p>Sight glasses</p>
<p>INDUSTRIAL APPLICATIONS</p>	<p>ICF valve station</p>	<p>Transcritical high pressure valve</p>	<p>Piping</p>
<p>COMMERCIAL APPLICATIONS</p>	<p>Safety relief valves</p>	<p>Transcritical gas bypass valve</p>	<p>Internal heat exchangers</p>
<p>SENSORS AND SWITCHES</p>	<p>Water valves</p>	<p>Multi ejectors</p>	

Coolselector® – Select the right component the coolest way

As the world gets more complicated we all need support to make the right choices.

Danfoss helps you make the right selections also for the other components that you will need in your professional daily life. Coolselector® calculates for you the performance of the component at your conditions, not just according to the standards.

Select the right component the coolest way

Do you pick your solenoid valve for your cold room by connection size alone?

Maybe you could actually go for a size smaller, or maybe the cold room would have done better if you had optimized the selection of that particular valve to the flow. Most professionals know that selecting a thermostatic expansion valve can turn out to be a tricky task if the conditions are not exactly standard conditions. You will need to take superheat, sub cooling and pressure drop into consideration to find the optimal valve with the right orifice. But also other components require consideration before selecting the best valve for the purpose. Even the solenoid valve should be checked for the specific performance under the conditions you intend to expose it to.

Coolselector® helps you optimize the choice of component and even tells you how the component behaves at the conditions given.

With the new version of Coolselector® you have all the components required to control a commercial refrigeration plant. Danfoss have now included the well-known compressor and condensing unit selection program RS+3 in Coolselector® which means that you no longer have to open several programs to calculate a compressor, a solenoid valve and an expansion valve. You can now do this in just one program.

The new section with compressors and condensing units also includes compressors for heat pumps which mean that you easily can select the best suited compressor for heat pump applications. Danfoss have on purpose kept the familiar and user friendly interface from RS+3 and just extended the content in accordance with the additional compressors. Coolselector® will continue development and enhancement and offers you automatic-updates also in future.

Please do not hesitate and go to the web address: coolselector.danfoss.com to down-load the program.

Table of contents

01 - Thermostatic expansion valves	6
T2 / TE2, Thermostatic expansion valves	6
TUA / TUAE, Thermostatic expansion valves	10
TE 5 - TE 55, Thermostatic expansion valves	14
TGE, Thermostatic expansion valve	18
02 - Electric expansion valves	22
AKV 10P / AKV 10PS, Electric expansion valves	22
AKV, Electric expansion valves	26
ETS 6, Electric expansion valve	28
ETS 12C / ETS 24C / ETS 25C / ETS 50C / ETS 100C, Electric expansion valves	30
03 - Solenoid valves	34
EVR version 2, Solenoid valves	34
Fluid controls overview	38
Media list for Danfoss Industrial Valves	40
EV220B, Solenoid valves	42
04 - Pressure switches and Thermostats	44
Industrial switches overview	44
KP, Pressure switch	46
KP, Thermostat	48
MP, Differential pressure switch	50
077B, Thermostat	52
05 - Pressure and temperature regulating valves	54
KVR / NRD, Condensing pressure regulator / Differential pressure valve	54
KVP, Evaporator pressure regulator	56
KVL, Crankcase pressure regulator	58
WVFX / WVO / WVS, Pressure operated water valves	60
AVTA, Thermostatic operated water valve	62
06 - Filter driers	64
DML, Hermetic filter drier (Liquid line filter)	64
DAS, Hermetic burn-out filter drier	66
DMB, Hermetic bi-flow filter drier	68
DCR, Filter drier with replaceable solid core	70
07 - Sight glasses	72
SGP, Sight glass	72
08 - Shut-off valves	74
GBC version 2, Shut-off ball valve	74
Type GBCT, Shut-off ball valve for R744 (CO ₂) high pressure	76
BML, Shut-off diaphragm valves	78
09 - Check valves	80
NRV / NRVH, Check valves	80

10 - Electronic controllers	84
ERC 211 / ERC 213 / ERC 214, Refrigeration controllers	84
LP-ETS kit and ETS, Superheat controller	86
AK-CC 250A, Universal refrigeration controller	88
AK-CC 55 Room/ Case controller (Pulse valve)	90
AK-PC 351, Capacity controller	94
AK-PC 551, Capacity controller	96
AK-PC 651, Capacity controller	98
AK-SM 800 series, System manager	100
Optyma™ Control, Single / Three-phase	102
11 - Sensors and Transmitters	106
Pressure transmitters overview	106
Temperature sensors overview	108
MBS 3000, Compact pressure transmitter	110
MBS 3100, Compact pressure transmitter	112
MBS 5100, Pressure transmitter	114
AKS, Pressure transmitters	116
EKS / AKS, Temperature sensors	118
DGS, Gas sensor	122
HGM, Multi-zone gas monitor	124
PGM-IR, Portable gas monitor	128
12 - Compressors	132
Secop reciprocating compressors produced for Danfoss - Direct current	132
Secop reciprocating compressors produced for Danfoss - Light commercial	134
Wiring diagram of small compressors	138
MTZ / NTZ Reciprocating compressors	142
MLZ / LLZ - Scroll compressors for refrigeration	148
H-Series, Scroll compressor	154
SH / SM / SY / SZ - S-Series, Scroll compressors	160
DSH / SH Series, Scroll compressors	166
Spare parts and accessories	168
13 - Condensing units	172
Optyma™ - Condensing Units	172
14 - Industrial refrigeration	178
Industrial refrigeration product overview	178
Danfoss Infogram	182
15 - Danfoss Infogram	184
Refrigeration Solutions for Refrigeration	184
Refrigeration Solutions for Air Conditioning and Heat Pumps	185

T2 / TE2, Thermostatic expansion valves

T2 / TE2 thermostatic expansion valves are used for liquid injection into evaporators on both refrigeration and air conditioning systems using fluorinated refrigerants e.g. R407C / R22, R134a, R404A / R507, R407C, R407F and R407A.

T2 / TE2 valves are supplied as a parts programme, with separate thermostatic element/valve body and orifice assembly. Available as angleway valves with flare x flare or flare x solder connection, with internal and external equalisation.

Features T2 / TE2



Laser-welded power element in stainless steel

- long diaphragm life
- high pressure tolerance and working pressure
- high corrosion resistance

Stainless steel capillary tube and bulb:

- high corrosion resistance
- high strength and vibration resistance

Flare or solder outlet

Laser-engraved label

Flare or solder pressure equalization

Easy adjustment of superheat setting

Interchangeable orifice assembly with dirt protection strainer

Flare inlet
Solder adaptor available as an option

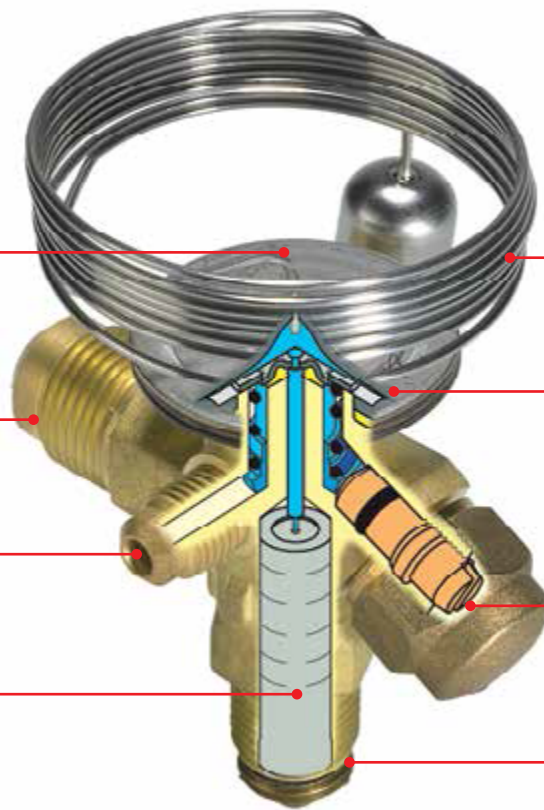

Facts

Applications:

- Traditional refrigeration
- Heat pump systems
- Air conditioning units
- Liquid coolers
- Transport refrigeration

Maximum working temperature:

- -60 to 10 °C / -76 to 50°F

Refrigerants:

- R22/R407C
- R23
- R236fa
- R404A/R507
- R407C
- R407F
- R134a/R513A
- R407A
- R448A
- R449A
- R452A

Capacity range:

- 0.18 – 6.51 TR / 0.64 – 22.9 kW

Benefit:

- Interchangeable orifice assembly
- Easy stocking
- Easy capacity matching
- Better service
- Can be supplied with MOP(Max. Operating Pressure)
- Protects the compressor motor against excessive evaporating pressure during normal operation

Technical data and ordering



Thermostatic element + Orifice

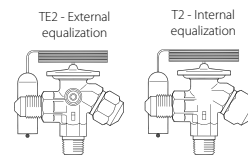

T2 / TE2

Thermostatic element with: bulb strap, without: orifice, strainer cone and nuts
Flare x flare connection

Refrigerant	Valve type	Pressure equalization Flare	Capillary Tube (m)	Connection Inlet x outlet		Code no.			
						Range N		Range NL	Range B
						-40 to +10°C		-40 to -15°C	-60 to -25°C
				in. x in.	mm x mm	Without MOP	MOP +15°C	MOP -10°C	MOP -20°C
R22	T 2	Int.	1.5	$\frac{3}{8} \times \frac{1}{2}$	10 x 12	068Z3206	068Z3208	-	-
	TE 2	Ext.				068Z3209	068Z3211	068Z3227	068Z3229
R134a	T 2	Int.				068Z3346	068Z3347	-	-
	TE 2	Ext.				068Z3348	068Z3349	-	-
R404A / R507	T 2	Int.				068Z3400	068Z3402	068Z3408	068Z3410
	TE 2	Ext.				068Z3403	068Z3405	068Z3409	-
R448A / R449A	T2	Int.				068Z3727	-	-	-
	T2	Ext.				068Z3728	-	-	-

T2 / TE2

Thermostatic element with: bulb strap, without: orifice,
Flare x solder connection

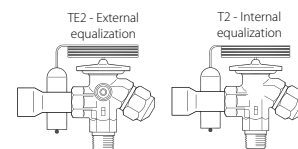

Refrigerant	Valve type	Pressure equalization Solder	Capillary Tube (m)	Connection		Code no.			
						Range N		Range NL	Range B
						-40 to +10°C		-40 to -15°C	-60 to -25°C
				Inlet Flare	Outlet ODF/solder	Without MOP	MOP +15°C	MOP -10°C	MOP -20°C
R22	T 2	-	1.5	$\frac{3}{8}$ in.	$\frac{1}{2}$ in.	068Z3281	-	-	-
	TE 2	$\frac{1}{4}$ in.				068Z3284	-	-	-
R134a	T 2	-				068Z3383	068Z3387	-	-
	TE 2	$\frac{1}{4}$ in.				068Z3385	068Z3389	-	-
R404A / R507	T 2	-				068Z3414	068Z3416	-	068Z3420
	TE 2	$\frac{1}{4}$ in.				068Z3415	068Z3417	068Z3430	-
R448A / R449A	T 2	-				068Z3729	-	-	-
	TE 2	$\frac{1}{4}$ in.				068Z3730	-	-	-

Technical data and ordering

T2 / TE2

Orifice assembly (Flare version)

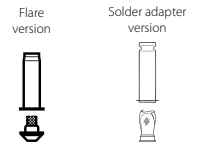

Orifice no.	Rated capacity in kW																Code no.	
	R22		R407C		R134a		R404A/R507		R513A		R452F		R448A		R449A		Flare X Flare version	Solder adaptor version
	MT	LT	MT	LT	MT	LT	MT	LT	MT	LT	MT	LT	MT	LT	MT	LT		
0X	0.95	0.88	0.93	0.83	0.69	0.58	0.64	0.56	0.57	0.46	0.68	0.6	0.91	0.83	0.89	0.81	068-2002	-
0	1.78	1.35	1.72	1.28	1.12	0.76	1.24	0.88	0.93	0.6	1.2	0.97	1.71	1.32	1.66	1.29	068-2003	068-2090
1	3.21	2.05	3.11	1.971	1.8	1.08	2.37	1.4	1.5	0.85	2.44	1.57	3.14	2.05	3.05	2.03	068-2010	068-2091
2	4.09	2.43	3.94	2.28	2.14	1.22	3.14	1.65	1.77	0.97	3.18	1.86	4.02	2.4	3.9	2.37	068-2015	068-2092
3	6.95	4.07	6.7	3.84	3.6	2.05	5.37	2.79	2.99	1.63	5.4	3.14	6.83	4.05	6.64	4.01	068-2006	068-2093
4	10.47	6.01	9.91	5.65	5.31	3.04	8.25	4.11	4.39	2.43	8.26	4.63	10.21	5.95	9.94	5.91	068-2007	068-2094
5	14.14	7.85	13.13	7.39	7	4	10.89	5.4	5.62	3.08	10.53	5.9	13.35	7.78	13.01	7.74	068-2008	068-2095
6	16.49	9.16	15.7	8.71	8.34	4.74	13.01	6.3	6.94	3.77	13.15	7.25	16.17	9.24	15.74	9.19	068-2009	-

Rated capacity at:

MT rated condition: Evaporating Temp. $t_e = -5\text{ }^\circ\text{C}$, Condensing Temp. $t_c = +43\text{ }^\circ\text{C}$, superheat=8K, Subcooling=2K

LT rated condition: Evaporating Temp. $t_e = -25\text{ }^\circ\text{C}$, Condensing Temp. $t_c = +43\text{ }^\circ\text{C}$, superheat=8K, Subcooling=2K

Out of the box, factory settings:

On systems charged with R134a; SSH = 5.0 °C (9.0 °F)

On systems charged with R513A; SSH = 6.1 °C (11 °F)

Note: For capacity of other refrigerant please refer datasheet of the valve or Coolselector.

Solder adaptor without orifice assembly



Connection - ODF solder	Code no.
1/4 in	068-2062
3/8 in	068-2060

) Including filter.

Filter as accessories



Filter type	Code no.
For flare connection	068-0003
For solder adaptor	068-0015

The solder adaptor is for use with thermostatic expansion valves T2 and TE2.

When the solder adaptor is fitted correctly it meets the sealing requirements of DIN 8964. The flare orifice in T2 and TE2 can be used with a solder adaptor when the orifice filter is replaced with a specific filter intended for solder adaptors. Only in this way the sealing requirements of DIN 8964 can be fulfilled.

Solder adaptors for filter driers (FSA) must not be used on the T2 inlet.

TUA / TUAE, Thermostatic expansion valves

TUA / TUAE stainless steel thermostatic expansion valves are used for liquid injection into evaporators on both refrigeration and air conditioning systems using fluorinated refrigerants e.g. R134a, R404A, R407C, R22, R507 and R410A. TUA / TUAE valves are compact in design, light weight and have steel / copper bi-metal connections for fast soldering.

TUA / TUAE valves are supplied as parts programme, with separate thermostatic element / valve body, and orifice assembly. TUA has internal equalization, TUAE external equalization. TUA / TUAE are straightway valves, and have adjustable superheat setting.

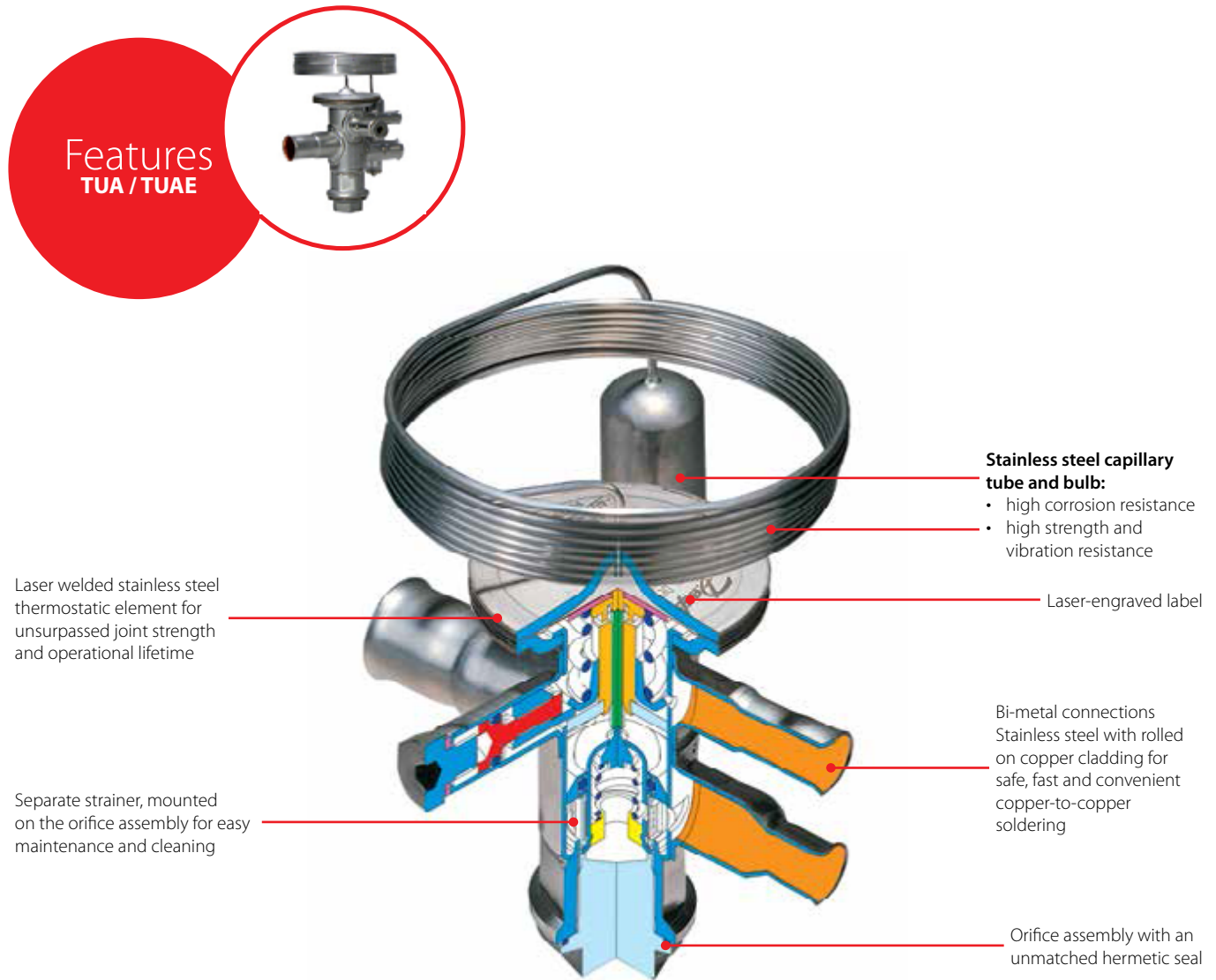

Features
TUA / TUAE

Stainless steel capillary tube and bulb:

- high corrosion resistance
- high strength and vibration resistance

Laser welded stainless steel thermostatic element for unsurpassed joint strength and operational lifetime

Laser-engraved label

Separate strainer, mounted on the orifice assembly for easy maintenance and cleaning

Bi-metal connections
Stainless steel with rolled on copper cladding for safe, fast and convenient copper-to-copper soldering

Orifice assembly with an unmatched hermetic seal

Facts

Applications:

- Traditional refrigeration
- Heat pump systems
- Air conditioning units
- Liquid coolers
- Ice cube machines
- Transport refrigeration

Maximum working temperature:

- -40 to 10 °C / -40 to 50°F

Refrigerants:

- R22/R407C
- R23
- R32
- R404A/R507
- R407C
- R407F
- R410A
- R508b
- R134a/R513A
- R407A
- R448A
- R449A

Capacity range:

- 0.11 – 6.56 TR / 0.42 – 23.1 kW

Benefit:

- The use of stainless steel makes the valves light and strong
- Bi-metal connections for safe, fast and convenient soldering
- Bi-flow function (TUAE: only orifice 1 – 8)

Technical data and ordering

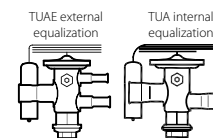

TUA / TUAE

Thermostatic element, without orifice or strainer, with bulb strap

Refrigerant	Type	Pressure equalization	Capillary Tube (m)	Connections Inlet x outlet	Code no.		
					Range N		Range
					-40 to +10°C		-40 to
					in.	Without MOP	MOP +15°C
R22	TUA	Int.	1.5	3/8 x 1/2	068U2235	-	-
	TUAE	Ext.			068U2237	-	-
R134A/R513A	TUA	Int.			068U2205	-	-
	TUAE	Ext.			068U2207	-	-
R404/R507	TUA	Int.			068U2285	-	-
	TUAE	Ext.			068U2287	068U2295	068U2303
R407C	TUA	Int.			068U2325	-	-
	TUAE	Ext.			068U2327	-	-
R410A	TUAE	Ext. 1/4 in.			068U1714	-	-

TUA / TUAE

Orifice assembly with filter and gasket

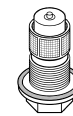

Valve type/ Orifice	R134A		R404A/R507		R407C		R22		R410A		Code no.
	MT	LT	MT	LT	MT	LT	MT	LT	MT	LT	
TU Orif. 0	0.35	0.16	0.41	0.19	0.56	0.34	0.56	0.35	0.91	0.58	068U1030
TU Orif. 1	0.52	0.2	0.61	0.24	0.8	0.49	0.83	0.52	1.21	0.78	068U1031
TU Orif. 2	0.6	0.3	0.72	0.35	0.93	0.55	0.97	0.59	1.48	0.89	068U1032
TU Orif. 3	0.8	0.46	0.94	0.53	1.23	0.75	1.28	0.8	1.9	1.2	068U1033
TU Orif. 4	1.32	0.73	1.61	0.86	2.069	1.22	2.16	1.28	3.4	1.95	068U1034
TU Orif. 5	1.77	0.99	2.16	1.15	2.77	1.6	2.89	1.72	4.54	2.61	068U1035
TU Orif. 6	2.75	1.54	3.37	1.79	4.3	2.49	4.5	2.68	7.12	4.05	068U1036
TU Orif. 7	3.63	2.03	4.45	2.36	5.68	3.29	5.95	3.53	9.39	5.34	068U1037
TU Orif. 8	5.38	3.01	6.52	3.4	8.34	4.83	8.73	5.2	13.56	7.84	068U1038
TU Orif. 9*	7.36	4.21	8.62	4.65	11.23	6.46	11.84	7	18.69	10.42	068U1039

Rated capacity at:

MT rated condition: Evaporating Temp. te = -5 °C, Condensing Temp. tc = +43 °C, superheat=8K, Subcooling=2K

LT rated condition: Evaporating Temp. te = -25 °C, Condensing Temp. tc = +43 °C, superheat=8K, Subcooling=2K

*TUAE with orifice no. 9 can't be used for Biflow operation.

Out of the box, factory settings:

On systems charged with R134a; SSH = 5.0 °C (9.0 °F)

On systems charged with R513A; SSH = 6.1 °C (11 °F)

Note: For capacity of other refrigerant please refer datasheet of the valve or Coolselector.

Technical data

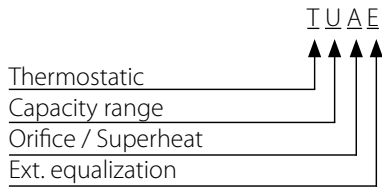

Orifice / Superheat

	Interchangeable	Adjustable
A	YES	YES
B	NO	YES
C	NO	NO

N = -40 °C – 10 °C / -40 – 50 °F
NM = -40 °C – -5 °C MOP 0 °C / -40 – 25 °F MOP 32 °F
NL = -40 °C – -15 °C with MOP - 10 °C / -40 – 5 °F MOP 14 °F
B = -60 °C – -25 °C / -75 – -15 °F

TUA
TUAE
TCAE

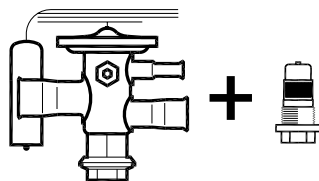

Thermostatic valve + Orifice

TUB
TUBE
TUC
TUCE
TCBE
TCCE

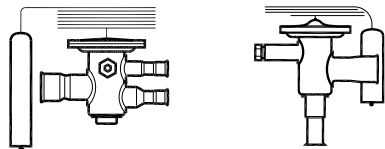

Thermostatic valve including Orifice

Valve types **TUB / TUBE / TUC / TUCE** and **TCBE / TCCE** can be replaced by **TUA / TUAE** and **TCAE** types

TE 5 - TE 55, Thermostatic expansion valves

TE 5 - TE 55 thermostatic expansion valves regulate the injection of refrigerant liquid into evaporators for medium sized plants. Injection is controlled by the refrigerant superheat. Therefore the valves are especially suitable for liquid injection in "dry" evaporators where the superheat at the evaporator outlet should always be kept constant.

TE 5 - TE 55 valves are supplied as parts programme, built up of three main components - thermostatic element, orifice assembly, and valve body with connections, and have external pressure equalization. Refrigerants: R22, R134a, R404A, R507, R407A, R407F and R407C.

Features TE 5 - TE 55



Laser-welded power element in stainless steel

- longer diaphragm life
- high pressure tolerance and working pressure
- high corrosion resistance

To ensure long operating life, the valve cone and seat are made of a special alloy with particularly good wear qualities

Stainless steel capillary tube and bulb

- high corrosion resistance
- high strength and vibration resistance

Large parts programme ensures minimal stocks

Easy adjustment of superheat setting

More connection possibilities

- solder x solder
- flare x flare
- flanges
- straightway or angleway

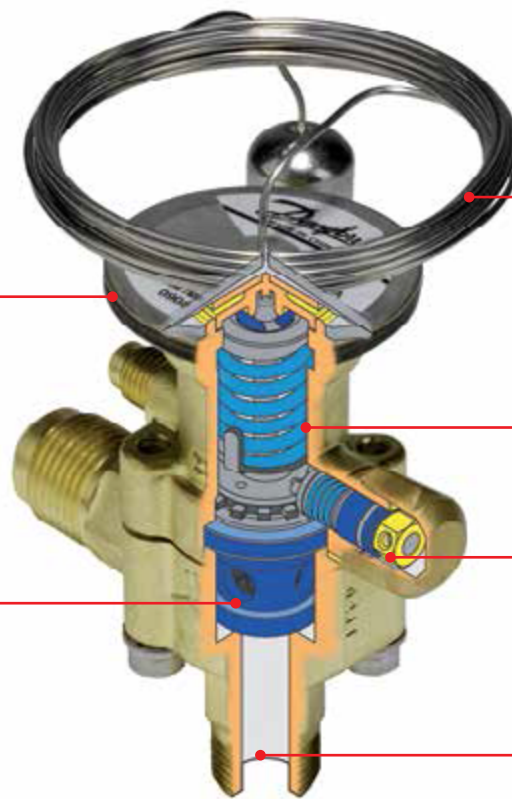

Facts

Applications:

- Traditional refrigeration
- Air conditioning units
- Water chillers

Maximum working pressure:

- 46 bar / 667 psig

Refrigerants:

- R1234yf
- R23
- R134a
- R404A/R507
- R407C
- R22
- R407A
- R407F
- R448A
- R449A
- R449B
- R454C
- R455A
- R452A
- R513A

Capacity range:

- 2.3 – 71 TR / 8.17 – 250 kW

Benefit:

- Balance port design
- Biflow with expansion in both directions
- Cylindrical bulb and patented bulb strap design

Technical data and ordering



Thermostatic element + Orifice + Valve body

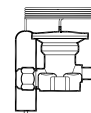

TE5 - TE 55

Thermostatic element - including bulb strap, Capillary Tube - 3M

Valve type	Refrigerant	Code no.
		Range N -40 to +10°C Without MOP
TE 5	R407C	067B3278
TE 12		067B3366
TE 55		067G3240
TE 5	R134a	067B3297
TE 12		067B3232
TE 5		067B3342
TE 12	R404A / R507	067B3347
TE 20		067B3352
TE 55		067G3302
TE 5	R22	067B3250
TE 12		067B3210
TE 20		067B3274
TE 55	R448 / R449	067G3205
TE 5		067B3252
TE 12		067B2512
TE 20	R448 / R449	067B3294
TE 55		067G3219

TE5 - TE 55

Body selection

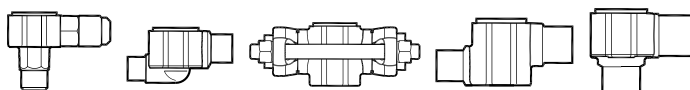

Type	Connection Inlet x Outlet		Code no.	
	in.	Flare angleway	Solder angleway	Solder straightway
TE 5	1/2 x 5/8	067B4013	067B4009 ¹⁾	067B4007 ¹⁾
	1/2 x 7/8	-	067B4010 ¹⁾	067B4008 ¹⁾
	5/8 x 7/8	-	067B4011 ¹⁾	-
	7/8 x 1 1/8	-	067B4034 ²⁾	-
TE 12	7/8 x 1 1/8	-	067B4023 ²⁾	067B4021 ²⁾
TE 20	7/8 x 1 1/8	-	067B4023 ²⁾	-
TE 55	1 1/8 x 1 3/8	-	067G4004 ³⁾	067G4003 ³⁾

1) ODF x ODF, 2) ODF x ODM, 3) ODM x ODM

ODF = Internal Diameter, ODM = External Diameter

Technical data and ordering

TE5 - TE 55

Orifice assembly

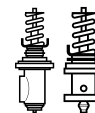

Valve type	Orifice no.	(kW)										Code no.
		R448A / R449A		R404A / R507		R22		R134a		R407C		
		MT	LT	MT	LT	MT	LT	MT	LT	MT	LT	
TE 5	0.5	9.3	6	7.4	4.8	9.8	6.6	6	3.8	9.5	6.2	067B2788
	1	17.2	11.1	13.7	8.8	18	12.3	11.1	7.1	17.6	11.5	067B2789
	2	24.1	15.7	19	12.4	25.2	17.3	15.5	10	24.7	16.2	067B2790
	3	30.2	19.6	24.1	15.5	31.9	21.6	19.8	12.7	31.1	20.2	067B2791
TE 12	4	41.4	26.2	32.95	20.9	43.5	29.1	27	17	42.4	27	067B2792
	5	46.7	29.7	43.6	26.1	51.5	34.1	33.4	21.5	46.8	28.5	067B2708
	6	61.4	37.8	54.6	31.8	68.1	43.9	43.9	27.6	61.1	36.2	067B2709
TE 20	7	75.1	46.7	66	37.8	84.5	54.9	56.6	36	75.4	44.6	067B2710
	8	107.4	66.8	76.8	46	117.8	77.2	69	43.4	101.6	63.9	067B2771
TE 55	9	117.2	69.7	85.5	49.8	132	82.4	79.22	48.5	112.5	68.2	067B2773
	10	129.3	75.1	106.5	59.6	148.1	91.1	94.3	55.7	133.6	79.9	067G2701
TE 55	11	140.3	81.6	115	64.6	161.1	99.3	103.6	61.3	145.1	87	067G2704
	12	150.7	86.5	124	68.6	174.4	106.1	112.7	65.9	156.1	92.5	067G2707
	13	181	102.7	148.3	81.3	210.9	127.1	138.5	80.4	187.7	110.2	067G2710

Rated capacity at:

MT rated condition: Evaporating Temp. $t_e = -5\text{ }^\circ\text{C}$, Condensing Temp. $t_c = +43\text{ }^\circ\text{C}$, superheat=8K, Subcooling=4K

LT rated condition: Evaporating Temp. $t_e = -25\text{ }^\circ\text{C}$, Condensing Temp. $t_c = +43\text{ }^\circ\text{C}$, superheat=8K, Subcooling=4K

Note: For capacity of other refrigerant please refer datasheet of the valve or Coolselector.

TGE, Thermostatic expansion valve

TGE is an innovatively designed series of thermostatic expansion valves for fluorinated refrigerants. TGE has copper connections upgraded for high-pressure applications with tight soldering, and is available with a wide variety of

connection types such as solder, flare, MIO, and ORFS, and a wide variety of connection sizes.

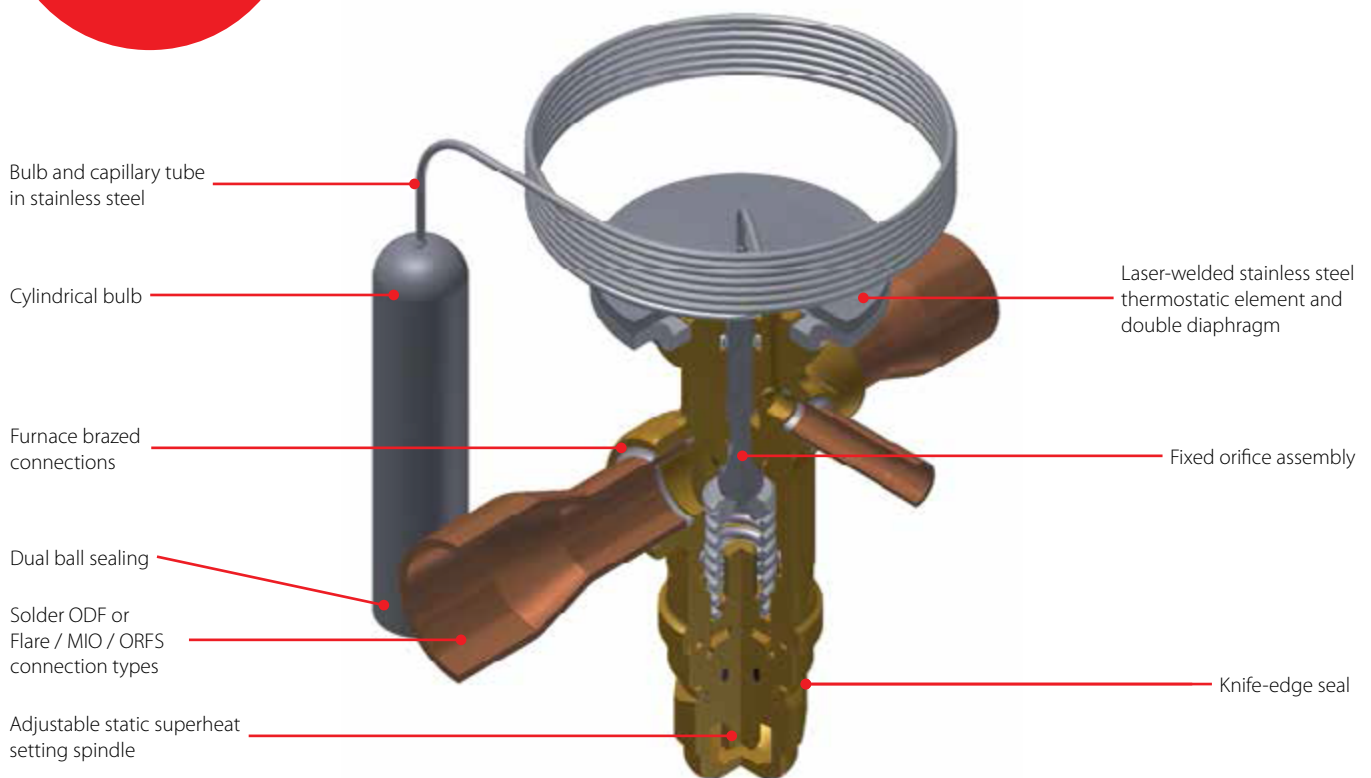

Facts

Applications:

- Water chillers
- Bus A/C
- Rooftop units
- Heat pumps
- Refrigerated containers and others A/C and other refrigeration system

Maximum working pressure:

- 46 bar / 667 psig

Refrigerants:

- R410A,
- R32,
- R452B,
- R22,
- R134a,
- R1234ze,
- R407F,
- R407A,
- R404A,
- R507,
- R407C
- R290
- R454B
- R452B

Capacity range:

- 2.2 – 52 TR / 8 – 182 kW

Benefit:

- Balance port design
- Biflow with expansion in both directions
- Cylindrical bulb and patented bulb strap design

Technical data and ordering

TGE

Thermostatic Expansion Valve with fixed Orifice

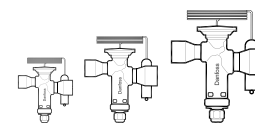

Refrigerant	Valve type	Orifice no.	Nominal capacity Q nom.		Inch version	
			MT	LT	Connection Solder ODF × ODF (in.)	Code no.
R407C	TGE 10	6	17.11	11.06	5/8 × 7/8	067N4155
	TGE 10	8	22.86	14.82	5/8 × 7/8	067N4156
	TGE 10	11	34.39	22.37	5/8 × 7/8	067N4157
	TGE 20	12.5	36.98	22.64	5/8 × 7/8	067N4159
	TGE 20	16	46.14	27.98	7/8 × 1 3/8	067N4162
	TGE 20	20	55.13	34.13	7/8 × 1 3/8	067N4163
	TGE 40	26	73.56	44.98	7/8 × 1 3/8	067N4165
R22	TGE 10	3	9.6	6.57	3/8 × 5/8	067N2150
	TGE 10	4	13.1	8.8	1/2 × 7/8	067N2152
	TGE 10	6	19.15	12.85	1/2 × 5/8	067N2153
	TGE 10	6	19.15	12.85	1/2 × 7/8	067N2154
	TGE 10	6	19.15	12.85	5/8 × 7/8	067N2155
	TGE 10	8	25.5	17.2	5/8 × 7/8	067N2156
	TGE 10	11	37.78	26.13	5/8 × 7/8	067N2157
	TGE 20	12.5	38.68	24.39	5/8 × 7/8	067N2159
	TGE 20	16	48.54	30.13	7/8 × 1 1/8	067N2162
	TGE 20	20	57.83	36.95	7/8 × 1 1/8	067N2163
	TGE 40	26	81.63	49.81	7/8 × 1 3/8	067N2165
R410A	TGE 10	4	15.44	10.46	1/2 × 7/8	067N3152
	TGE 10	6	22.51	15.2	1/2 × 7/8	067N3154
	TGE 10	6	22.51	15.2	5/8 × 7/8	067N3155
	TGE 10	8	29.92	20.32	5/8 × 7/8	067N3156
	TGE 10	11	44.52	30.92	5/8 × 7/8	067N3157
	TGE 20	20	72.55	46.89	7/8 × 1 1/8	067N3163
	TGE 40	30	110.6	68.25	7/8 × 1 3/8	067N3168
R134A	TGE 10	4	7.48	4.8	1/2 × 7/8	067N5152
	TGE 10	6	11.13	7.15	1/2 × 5/8	067N5153
	TGE 10	8	15.11	9.75	5/8 × 7/8	067N5156
	TGE 10	11	22.39	14.45	5/8 × 7/8	067N5157
R404/R507	TGE 10	6	12.75	8.186	1/2 × 7/8	067N6151
	TGE 10	8	17.03	10.99	5/8 × 7/8	067N6150
	TGE 10	11	25.17	16.56	5/8 × 7/8	067N6154
	TGE 20	12.5	27.86	16.96	5/8 × 7/8	067N6158
	TGE 20	16	34.92	21.08	5/8 × 1 1/8	067N6155

Range N = -40 → +10°C OS = 4 K

Technical data and ordering

TGE cross reference

TRE Series

TGE Valves (fixed Orifice) „New Replacement Series						TDE & TRE Valves (fixed Orifice) "Obsolete Range"							
TGE Single Pack	Description	Body	Intel-Outlet	OEM Pack (Qty)	Old Code	Description2	Refrigement	Range	Orif	KW	SH	Inlet	Outlet
067N4156	TGEZ 7	TGE 10	5/8 X 7/8	<	067L1100	TRE 10-BZ	R407C	-40 - 10 °C	8	25,00 kW	4,00 °C	5/8in	7/8in
067N4157	TGEZ 10	TGE 10	5/8 X 7/8	<	067L1101	TRE10-10Z	R407C	-40 - 10 °C	11	36,00 kW	4,00 °C	5/8in	7/8in
067N4159	TGEZ 12	TGE 20	5/8 X 7/8	<	067L1102	TRE20-12Z	R407C	-40 - 10 °C	12.5	42,00 kW	4,00 °C	5/8in	7/8in
067N5156	TGEN 4.5	TGE 10	5/8 X 7/8	<	067L1103	TRE10-5N	R134a	-40 - 10 °C	8	17,00 kW	4,00 °C	5/8in	7/8in
067N4157	TGEZ 10	TGE 10	5/8 X 7/8	<	067L1104	TRE20-10Z	R407C	-40 - 10 °C	11	36,00 kW	4,00 °C	5/8in	7/8in
067N5157	TGEN 7	TGE 10	5/8 X 7/8	<	067L1106	TRE10-7N	R134a	-40 - 10 °C	11	24,00 kW	4,00 °C	5/8in	7/8in
067N4156	TGEZ7	TGE 10	5/8 X 7/8	<	067L1112	TRE10-8Z	R407C	-40 - 10 °C	8	25,00 kW	4,00 °C	5/8in	7/8in
067N2156	TGEX 7.5	TGE 10	5/8 X 7/8	<	067L1121	TRE10-8X	R22	-40 - 10 °C	8	27,00 kW	4,00 °C	5/8in	7/8in
067N2157	TGEX 11	TGE 10	5/8 X 7/8	<	067L1124	TRE10-10X	R22	-40 - 10 °C	11	38,00 kW	4,00 °C	5/8in	7/8in
067N3155	TGEL 6.5	TGE 10	5/8 X 7/8	<	067L1129	TREL10-8	R410A	-40 - 10 °C	6	24,00 kW	4,00 °C	5/8in	7/8in
067N3156	TGEL 9	TGE 10	5/8 X 7/8	<	067L1131	TREL10-10	R410A	-40 - 10 °C	8	32,00 kW	4,00 °C	5/8in	7/8in
067N3157	TGEL 13	TGE 10	5/8 X 7/8	<	067L1135	TREL10-12.5	R410A	-40 - 10 °C	11	45,00 kW	4,00 °C	5/8in	7/8in
067N3232	TGEL 15	TGE 20	7/8 X 11/8	<	067L1139	TREL10-15	R410A	-40 - 10 °C	12.5	54,00 kW	4,00 °C	7/8in	1 1/8 in
067N5157	TGEN 7	TGE 10	5/8 X 7/8	<	067L1141	TRE20-7N	R134a	-40 - 10 °C	11	24,00 kW	4,00 °C	5/8in	7/8in
067N5162	TGEN 10	TGE 20	7/8 X 11/8	<	067L1150	TRE20-11N	R134a	-40 - 10 °C	16	37,00 kW	4,00 °C	7/8in	1 1/8in
067N5163	TGEN 12	TGE 20	7/8 X 11/8	<	067L1153	TRE20-14N	R134a	-40 - 10 °C	20	44,00 kW	4,00 °C	7/8in	1 1/8in
067N4162	TGEN 15	TGE 20	7/8 X 11/8	<	067L1167	TRE20-15Z	R407C	-40 - 10 °C	16	53,00 kW	4,00 °C	7/8in	1 1/8in
067N4163	TGEZ 18	TGE 20	7/8 X 11/8	<	067L1170	TRE20-20Z	R407C	-40 - 10 °C	20	62,00 kW	4,00 °C	7/8in	1 1/8in
067N2157	TGEX 11	TGE 10	5/8 X 7/8	<	067L1175	TRE20-10X	R22	-40 - 10 °C	11	38,00 kW	4,00 °C	5/8in	7/8in
067N2159	TGEX 12	TGE 20	5/8 X 7/8	<	067L1179	TRE20-12.5X	R22	-40 - 10 °C	12.5	43,00 kW	4,00 °C	5/8in	7/8in
067N2162	TGEX 15	TGE 20	7/8 X 11/8	<	067L1184	TRE20-15X	R22	-40 - 10 °C	16	54,00 kW	4,00 °C	7/8in	1 1/8in
067N2163	TGEX 18	TGE 20	7/8 X 11/8	<	067L1187	TRE20-20X	R22	-40 - 10 °C	20	63,00 kW	4,00 °C	7/8in	1 1/8in
067N2164	TGEX 18	TGE 20	7/8 X 13/8	<	067L1188	TRE20-20X	R22	-40 - 10 °C	20	63,00 kW	4,00 °C	7/8in	1 3/8in
067N3162	TGEL 19	TGE 20	7/8 X 11/8	<	067L1194	TREL20-20	R410A	-40 - 10 °C	16	68,00 kW	4,00 °C	7/8in	1 1/8in
067N3163	TGEL 23	TGE 20	7/8 X 11/8	<	067L1197	TREL20-25	R410A	-40 - 10 °C	20	79,00 kW	4,00 °C	7/8in	1 1/8in
067N2156	TGEX 7.5	TGE 10	5/8 X 7/8	067N2176 (12)	067L2121	TRE10-8X	R22	-40 - 10 °C	8	27,00 kW	4,00 °C	5/8in	7/8in
067N2157	TGEX 11	TGE 10	5/8 X 7/8	067N2177 (12)	067L2124	TRE10-10X	R22	-40 - 10 °C	11	38,00 kW	4,00 °C	5/8in	7/8in
067N3155	TGEL 6.5	TGE 10	5/8 X 7/8	067N3175 (12)	067L2129	TREL10-8	R410A	-40 - 10 °C	6	24,00 kW	4,00 °C	5/8in	7/8in
067N3248	TGEL 10	TGE 10	5/8 X 7/8	<	067L2130	TREL10-10	R410A	-40 - 10 °C	8	32,00 kW	4,00 °C	5/8in	5/8in
067N3156	TGEL 9	TGE 10	5/8 X 7/8	067N3176 (12)	067L2131	TREL10-10	R410A	-40 - 10 °C	8	32,00 kW	4,00 °C	5/8in	7/8in
067N3249	TGEL 10	TGE 10	5/8 X 7/8	<	067L2134	TREL10-12.5	R410A	-40 - 10 °C	11	45,00 kW	4,00 °C	5/8in	5/8in
067N3157	TGEL 13	TGE 10	5/8 X 7/8	067N3177 (12)	067L2135	TREL10-12.5	R410A	-40 - 10 °C	11	45,00 kW	4,00 °C	5/8in	7/8in
067N4159	TGEZ 12	TGE 20	5/8 X 7/8	067N4179 (8)	067L2162	TRE20-12.5Z	R407C	-40 - 10 °C	12.5	42,00 kW	4,00 °C	5/8in	7/8in
067N2157	TGEX 11	TGE 10	5/8 X 7/8	067N2177 (12)	067L2175	TRE20-10X	R22	-40 - 10 °C	11	38,00 kW	4,00 °C	5/8in	7/8in
067N2159	TGEX 12	TGE 20	5/8 X 7/8	067N2179 (8)	067L2179	TRE20-12.5X	R22	-40 - 10 °C	12.5	43,00 kW	4,00 °C	5/8in	7/8in
067N2162	TGEX 15	TGE 20	7/8 X 11/8	067N2182 (8)	067L2184	TRE20-15X	R22	-40 - 10 °C	16	54,00 kW	4,00 °C	7/8in	1 1/8in
067N2163	TGEX 18	TGE 20	7/8 X 11/8	067N2183 (8)	067L2187	TRE20-20X	R22	-40 - 10 °C	20	63,00 kW	4,00 °C	7/8in	1 1/8in
067N2165	TGEX 26	TGE 40	7/8 X 13/8	<	067L3105	TRE40-25X	R22	-40 - 10 °C	26	92,00 kW	4,00 °C	7/8in	1 3/8in
067N2168	TGEX 30	TGE 40	11/8 X 13/8	<	067L3109	TRE40-30X	R22	-40 - 10 °C	30	104,00 kW	4,00 °C	1 1/8 in	1 3/8 in
067N2169	TGEX 38	TGE 40	11/8 X 13/8	<	067L3112	TRE40-40X	R22	-40 - 10 °C	40	134,00 kW	4,00 °C	1 1/8 in	1 3/8 in
067N3166	TGEL 31	TGE 40	11/8 X 13/8	<	067L3120	TRE40-30L	R410A	-40 - 10 °C	26	110,00 kW	4,00 °C	1 1/8 in	1 3/8 in
067N3168	TGEL 35	TGE 40	11/8 X 13/8	<	067L3124	TRE40-40L	R410A	-40 - 10 °C	30	125,00 kW	4,00 °C	1 1/8 in	1 3/8 in
067N3169	TGEL 46	TGE 40	11/8 X 13/8	<	067L3128	TRE40-55L	R410A	-40 - 10 °C	40	161,00 kW	4,00 °C	1 1/8 in	1 3/8 in
067N4163	TGEZ 18	TGE 20	7/8 X 11/8	<	067L3130	TRE40-20Z	R407C	-40 - 10 °C	20	62,00 kW	4,00 °C	7/8in	1 1/8in
067N4165	TGEZ 24	TGE 40	7/8 X 13/8	<	067L3134	TRE40-25Z	R407C	-40 - 10 °C	26	84,00 kW	4,00 °C	7/8in	1 3/8in
067N4167	TGEZ 27	TGE 40	7/8 X 13/8	<	067L3138	TRE40-30Z	R407C	-40 - 10 °C	30	309,00 kW	4,00 °C	7/8in	1 3/8in
067N4169	TGEZ 34	TGE 40	11/8 X 13/8	<	067L3140	TRE40-40Z	R407C	-40 - 10 °C	40	121,00 kW	4,00 °C	1 1/8in	1 3/8in
067N5163	TGEN 12	TGE 20	7/8 X 11/8	<	067L3143	TRE40-14N	R134a	-40 - 10 °C	20	44,00 kW	4,00 °C	7/8in	1 1/8in
067N5165	TGEN 17	TGE 40	7/8 X 13/8	<	067L3147	TRE40-16N	R134a	-40 - 10 °C	26	61,00 kW	4,00 °C	7/8in	1 3/8in
067N5169	TGEN 25	TGE 40	11/8 X 13/8	<	067L3154	TRE40-25N	R134a	-40 - 10 °C	40	87,00 kW	4,00 °C	1 1/8in	1 3/8in

Technical data and ordering

TGE cross reference

TRE Series

TGE Valves (fixed Orifice) „New Replacement Series						TDE & TRE Valves (fixed Orifice) "Obsolete Range"							
TGE Single Pack	Description	Body	Intel-Outlet	OEM Pack (Qty)	Old Code	Description2	Refrigement	Range	Orif	KW	SH	Inlet	Outlet
067N2156	TGEX 7.5	TGE 10	5/8 X 7/8	067N2176(12)	068H5101	TDEX7.5	R22	-40 - 10 °C	8	27,00 kW	4,00 °C	5/8in	7/8in
067N2159	TGEX 12	TGE 20	5/8 X 7/8	067N2179(8)	068H5121	TDEX12.5	R22	-40 - 10 °C	12.5	43,00 kW	4,00 °C	5/8in	7/8in
067N2163	TGEX 18	TGE 20	7/8X11/8	067N2183(8)	068H5124	TDEX19	R22	-40 - 10 °C	20	63,00 kW	4,00 °C	7/8in	1 1/8in
067N2162	TGEX 15	TGE 20	7/8X11/8	067N2182(8)	068H5127	TDEX16	R22	-40 - 10 °C	16	54,00 kW	4,00 °C	7/8in	1 1/8in
067N2156	TGEX 7.5	TGE 10	5/8X7/8	067N2176(12)	068H5128	TDEX8	R22	-40 - 10 °C	8	27,00 kW	4,00 °C	5/8in	7/8in
067N4150	TGEZ 2.5	TGE 10	3/8X5/8	<	068H7000	TDEZ3	R407C	-40 - 10 °C	3	9,00 kW	4,00 °C	3/8in	5/8in
067N4151	TGEZ 2.5	TGE 10	1/2X5/8	<	068H7002	TDEZ3	R407C	-40 - 10 °C	3	9,00 kW	4,00 °C	1/2in	5/8in
067N4152	TGEZ 3.5	TGE 10	1/2X7/8	<	068H7004	TDEZ4	R407C	-40 - 10 °C	4	13,00 kW	4,00 °C	1/2in	7/8in
067N4153	TGEZ 5	TGE 10	1/2X5/8	<	068H7006	TDEZ6	R407C	-40 - 10 °C	6	19,00 kW	4,00 °C	1/2in	5/8in
067N4155	TGEZ 5	TGE 10	5/8X7/8	<	068H7010	TDEZ6	R407C	-40 - 10 °C	6	19,00 kW	4,00 °C	5/8in	7/8in
067N4156	TGEZ 7	TGE 10	5/8X7/8	<	068H7012	TDEZ7.5	R407C	-40 - 10 °C	8	25,00 kW	4,00 °C	5/8in	7/8in
067N4156	TGEZ 7	TGE 10	5/8X7/8	<	068H7014	TDEZ8	R407C	-40 - 10 °C	8	25,00 kW	4,00 °C	5/8in	7/8in
067N4163	TGEZ 18	TGE 20	7/8X11/8	<	068H7026	TDEZ16	R407C	-40 - 10 °C	20	62,00 kW	4,00 °C	7/8in	1 1/8in
067N4163	TGEZ 18	TGE 20	7/8X11/8	<	068H7030	TDEZ20	R407C	-40 - 10 °C	20	62,00 kW	4,00 °C	7/8in	1 1/8in
067N4165	TGEZ 24	TGE 40	7/8X13/8	<	068H7032	TDEZ26	R407C	-40 - 10 °C	26	84,00 kW	4,00 °C	7/8in	1 3/8in
067N4169	TGEZ 34	TGE 40	11/8X13/8	<	068H7036	TDEZ30	R407C	-40 - 10 °C	40	121,00 kW	4,00 °C	1 1/8in	1 3/8in
067N4169	TGEZ 34	TGE 40	11/8X13/8	<	068H7038	TDEZ40	R407C	-40 - 10 °C	40	121,00 kW	4,00 °C	1 1/8in	1 3/8in
067N2150	TGEX 3	TGE 10	3/8X5/8	<	068H7050	TDEX3	R22	-40 - 10 °C	3	10,00 kW	4,00 °C	3/8in	5/8in
067N2152	TGEX 4	TGE 10	1/2X7/8	<	068H7054	TDEX4	R22	-40 - 10 °C	4	14,00 kW	4,00 °C	1/2in	7/8in
067N2153	TGEX 6	TGE 10	1/2X5/8	<	068H7056	TDEX6	R22	-40 - 10 °C	6	20,00 kW	4,00 °C	1/2in	5/8in
067N2154	TGEX 6	TGE 10	1/2X7/8	<	068H7058	TDEX6	R22	-40 - 10 °C	6	20,00 kW	4,00 °C	1/2in	7/8in
067N2155	TGEX 6	TGE 10	5/8X7/8	<	068H7060	TDEX6	R22	-40 - 10 °C	6	20,00 kW	4,00 °C	5/8in	7/8in
067N2156	TGEX 7.5	TGE 10	5/8X7/8	<	068H7062	TDEX7.5	R22	-40 - 10 °C	8	27,00 kW	4,00 °C	5/8in	7/8in
067N2156	TGEX 7.5	TGE 10	5/8X7/8	<	068H7064	TDEX8	R22	-40 - 10 °C	8	27,00 kW	4,00 °C	5/8in	7/8in
067N2159	TGEX 12	TGE 20	5/8X7/8	<	068H7066	TDEX11	R22	-40 - 10 °C	12.5	43,00 kW	4,00 °C	5/8in	7/8in
067N2159	TGEX 12	TGE 20	5/8X7/8	<	068H7070	TDEX12.5	R22	-40 - 10 °C	12.5	43,00 kW	4,00 °C	5/8in	7/8in
067N2163	TGEX 18	TGE 20	7/8X11/8	<	068H7076	TDEX16	R22	-40 - 10 °C	20	63,00 kW	4,00 °C	7/8in1	1/8in
067N2163	TGEX 18	TGE 20	7/8X11/8	<	068H7080	TDEX20	R22	-40 - 10 °C	20	63,00 kW	4,00 °C	7/8in1	1/8in
067N2165	TGEX 26	TGE 40	7/8X13/8	<	068H7082	TDEX26	R22	-40 - 10 °C	26	92,00 kW	4,00 °C	7/8in1	3/8in
067N2169	TGEX 38	TGE 40	11/8X13/8	<	068H7086	TDEX30	R22	-40 - 10 °C	40	134,00 kW	4,00 °C	1 1/8in	1 3/8in
067N2169	TGEX 38	TGE 40	11/8X13/8	<	068H7088	TDEX40	R22	-40 - 10 °C	40	134,00 kW	4,00 °C	1 1/8in	1 3/8in
067N2155	TGEX 6	TGE 10	5/8X7/8	067N2175(12)	068H8062	TDEX7.5	R22	-40 - 10 °C	6	20,00 kW	4,00 °C	5/8in	7/8in
067N2157	TGEX 11	TGE 10	5/8X7/8	067N2177(12)	068H8068	TDEX11	R22	-40 - 10 °C	11	38,00 kW	4,00 °C	5/8in	7/8in
067N2156	TGEX 7.5	TGE 10	5/8X7/8	067N2176(12)	068H8082	TDEX8	R22	-40 - 10 °C	8	27,00 kW	4,00 °C	5/8in	7/8in
067N2159	TGEX 12	TGE 20	5/8X7/8	067N2179(8)	068H8084	TDEX11	R22	-40 - 10 °C	12.5	43,00 kW	4,00 °C	5/8in	7/8in
067N2159	TGEX 12	TGE 20	5/8X7/8	067N2179(8)	068H8088	TDEX12.5	R22	-40 - 10 °C	12.5	43,00 kW	4,00 °C	5/8in	7/8in
067N2163	TGEX 18	TGE 20	7/8X11/8	067N2183(8)	068H8094	TDEX16	R22	-40 - 10 °C	20	63,00 kW	4,00 °C	7/8in	1 1/8in
067N2163	TGEX 18	TGE 20	7/8X11/8	067N2183(8)	068H8098	TDEX20	R22	-40 - 10 °C	20	63,00 kW	4,00 °C	7/8in	1 1/8in
067N2156	TGEX 7.5	TGE 10	5/8X7/8	<	068H8106	TDEX8	R22	-40 - 10 °C	8	27,00 kW	4,00 °C	5/8in	7/8in
067N2157	TGEX 11	TGE 10	5/8X7/8	<	068H8108	TDEX11	R22	-40 - 10 °C	11	38,00 kW	4,00 °C	5/8in	7/8in
067N2159	TGEX 12	TGE 20	5/8X7/8	<	068H8112	TDEX12.5	R22	-40 - 10 °C	12.5	43,00 kW	4,00 °C	5/8in	7/8in
067N2162	TGEX 15	TGE 20	7/8X11/8	<	068H8118	TDEX16	R22	-40 - 10 °C	18	54,00 kW	4,00 °C	7/8in	1 1/8in
067N2163	TGEX 18	TGE 20	7/8X11/8	<	068H8120	TDEX19	R22	-40 - 10 °C	20	63,00 kW	4,00 °C	7/8in	1 1/8in
067N4155	TGEZ 5	TGE 10	5/8X7/8	067N4175(12)	068H8214	TDEZ6	R407C	-40 - 10 °C	6	19,00 kW	4,00 °C	5/8in	7/8in
067N4159	TGEZ 12	TGE 20	5/8X7/8	067N4179(8)	068H8224	TDEZ12.5	R407C	-40 - 10 °C	12.5	42,00 kW	4,00 °C	5/8in	7/8in
067N4159	TGEZ 12	TGE 20	5/8X7/8	067N4179(8)	068H8236	TDEZ11	R407C	-40 - 10 °C	12.5	42,00 kW	4,00 °C	5/8in	7/8in
067N4159	TGEZ 12	TGE 20	5/8X7/8	067N4179(8)	068H8240	TDEZ12.5	R407C	-40 - 10 °C	12.5	42,00 kW	4,00 °C	5/8in	7/8in
067N4156	TGEZ 7	TGE 10	5/8X7/8	<	068H8260	TDEZ8	R407C	-40 - 10 °C	8	25,00 kW	4,00 °C	5/8in	7/8in
067N4158	TGEZ 10	TGE 10	5/8X11/8	<	068H8264	TDEZ11	R407C	-40 - 10 °C	11	36,00 kW	4,00 °C	5/8in	1 1/8in
067N4162	TGEZ 15	TGE 20	7/8X11/8	<	068H8272	TDEZ16	R407C	-40 - 10 °C	16	53,00 kW	4,00 °C	7/8in	1 1/8in
067N4163	TGEZ 18	TGE 20	7/8X11/8	<	068H8274	TDEZ19	R407C	-40 - 10 °C	20	62,00 kW	4,00 °C	7/8in	1 1/8in
067N5150	TGEN 1.5	TGE 10	3/8X5/8	<	068H8408	TDEN2.3	R134a	-40 - 10 °C	3	6,00 kW	4,00 °C	3/8in	5/8in
067N5151	TGEN 1.5	TGE 10	1/2X5/8	<	068H8410	TDEN2.3	R134a	-40 - 10 °C	3	6,00 kW	4,00 °C	1/2in	5/8in
067N5152	TGEN 2.5	TGE 10	1/2X7/8	<	068H8412	TDEN3.1	R134a	-40 - 10 °C	4	8,00 kW	4,00 °C	1/2in	7/8in
067N5153	TGEN 3.5	TGE 10	1/2X5/8	<	068H8414	TDEN4.6	R134a	-40 - 10 °C	6	12,00 kW	4,00 °C	1/2in	5/8in
067N5154	TGEN 3.5	TGE 10	1/2X7/8	<	068H8416	TDEN4.6	R134a	-40 - 10 °C	6	12,00 kW	4,00 °C	1/2in	7/8in
067N5156	TGEN 4.5	TGE 10	5/5X7/8	<	068H8420	TDEN5.8	R134a	-40 - 10 °C	8	17,00 kW	4,00 °C	5/8in	7/8in
067N5156	TGEN 4.5	TGE 10	5/5X7/8	<	068H8436	TDEN6.2	R134a	-40 - 10 °C	8	17,00 kW	4,00 °C	5/8in	7/8in
067N5157	TGEN 7	TGE 10	5/8X7/8	<	068H8438	TDEN8.5	R134a	-40 - 10 °C	11	24,00 kW	4,00 °C	5/8in	7/8in
067N5160	TGEN 8	TGE 20	5/8X11/8	<	068H8444	TDEN9.6	R134a	-40 - 10 °C	12.5	29,00 kW	4,00 °C	5/8in	1 1/8in
067N5162	TGEN 10	TGE 20	7/8X11/8	<	068H8448	TDEN12.3	R134a	-40 - 10 °C	16	37,00 kW	4,00 °C	7/8in	1 1/8in
067N5163	TGEN 12	TGE 20	7/8X11/8	<	068H8450	TDEN14.6	R134a	-40 - 10 °C	20	44,00 kW	4,00 °C	7/8in	1 1/8in
067N5156	TGEN 4.5	TGE 10	5/8X7/8	<	068H8468	TDEN5.8	R134a	-40 - 10 °C	8	17,00 kW	4,00 °C	5/8in	7/8in
067N5162	TGEN 10	TGE 20	7/8X11/8	<	068H8480	TDEN12.3	R134a	-40 - 10 °C	16	37,00 kW	4,00 °C	7/8in	1 1/8in
067N5163	TGEN 12	TGE 20	7/8X11/8	<	068H8482	TDEN14.6	R134a	-40 - 10 °C	20	44,00 kW	4,00 °C	7/8in	1 1/8in
067N5163	TGEN 12	TGE 20	7/8X11/8	<	068H8500	TDEN15.4	R134a	-40 - 10 °C	20	44,00 kW	4,00 °C	7/8in	1 1/8in
067N5165	TGEN 17	TGE 40	7/8X13/8	<	068H8502	TDEBN20	R134a	-40 - 10 °C	26	61,00 kW	4,00 °C	7/8in	1 3/8in
067N5169	TGEN 25	TGE 40	11/8X13/8	<	068H8506	TDEBN23.1	R134a	-40 - 10 °C	40	87,00 kW	4,00 °C	1 1/8in	1 3/8in
067N5169	TGEN 25	TGE 40	11/8X13/8	<	068H8508	TDEBN30.8	R134a	-40 - 10 °C	40	87,00 kW	4,00 °C	1 1/8in	1 3/8in
067N6151	TGES 4	TGE 10	1/2X7/8	<	068H8750	TDES4.5	R404A	-40 - 10 °C	6	14,00 kW	4,00 °C	1/2in	7/8in
067N6150	TGES 5	TGE 10	5/8X7/8	<	068H8751	TDES6	R404A	-40 - 10 °C	8	18,00 kW	4,00 °C	5/8in	7/8in
067N6154	TGES 7.5	TGE 10	5/8X7/8	<	068H8752	TDES8.3	R404A	-40 - 10 °C	11	26,00 kW	4,00 °C	5/8in	7/8in
067N6158	TGES 9	TGE 20	5/8X7/8	<	068H8753	TDES9.4	R404A	-40 - 10 °C	12.5	31,00 kW	4,00 °C	5/8in	7/8in
067N6155	TGES 11	TGE 20	5/8X11/8	<	068H8754	TDES12.1	R404A	-40 - 10 °C	16	39,00 kW	4,00 °C	5/8in	1 1/8in
067N6162	TGES 13	TGE 20	7/8X11/8	<	068H8756	TDES15.1	R404A	-40 - 10 °C	20	45,00 kW	4,00 °C	7/8in	1 1/8in
067N6161	TGES 18	TGE 40	7/8X13/8	<	068H8757	TDES19.6	R404A	-40 - 10 °C	26	64,00 kW	4,00 °C	7/8in	1 3/8in
067N2161	TGEX 15(5/8 x 11/8")	TGE 20	5/8X7/8	067N2244(8)	068H8761	TDEX16	R22	-40 - 10 °C	16	54,00 kW	4,00 °C	5/8in	7/8in
067N2163	TGEX 18	TGE 20	7/8X11/8	067N2183(8)	068H8783	TDEBX16	R22	-40 - 10 °C	20	63,00 kW	4,00 °C	7/8in	1 1/8in

AKV 10P / AKV 10PS, Electric expansion valves

AKV 10P and AKV10PS are electric operated expansion valves designed for refrigerating plants. The AKV 10P and AKV 10PS valves are normally controlled by a controller from Danfoss range of ADAP- KOOL® controllers, that ensures a precise liquid injection into evaporators.

AKV 10P and AKV10PS valves are fully serviceable valves and are supplied as a parts programme with separate valve body and coil (with terminal box, cable or DIN plug).

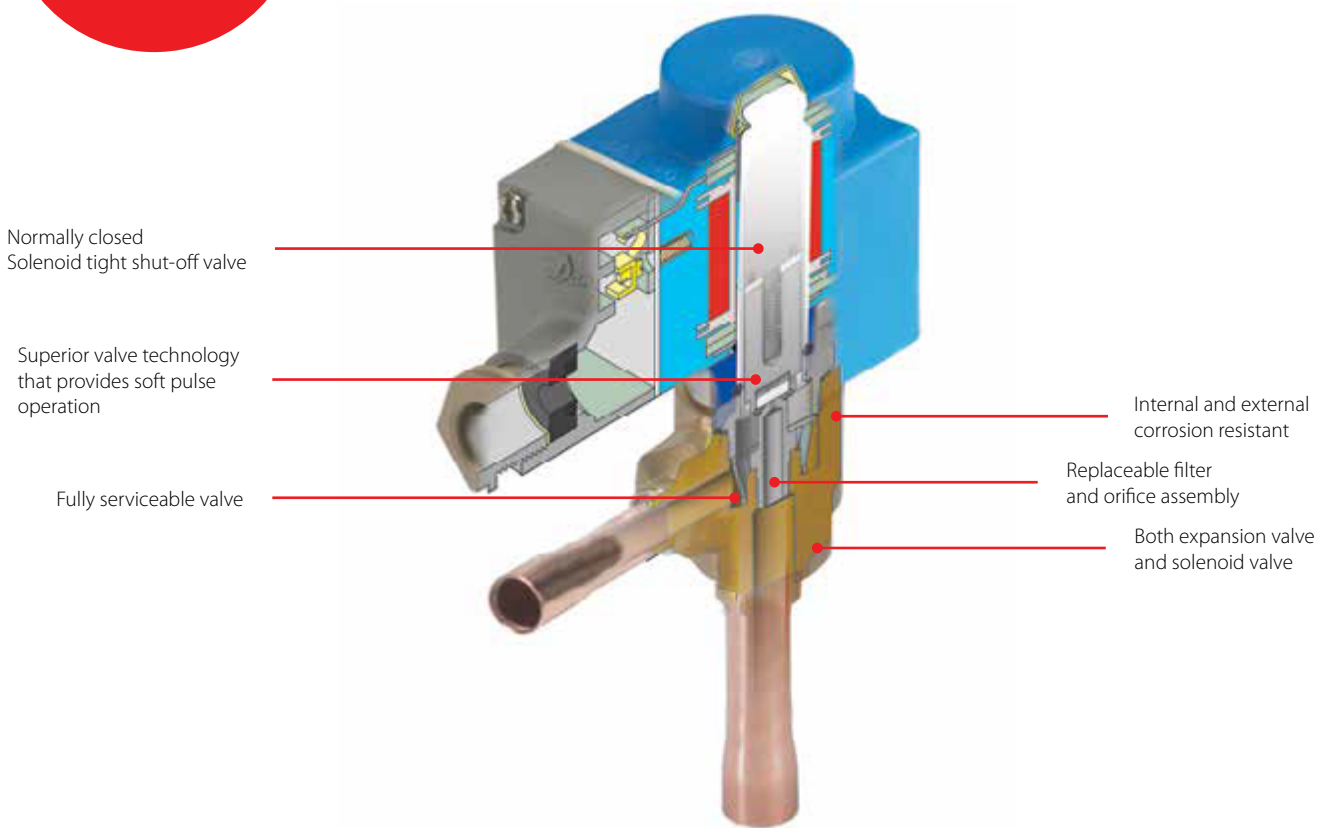

Facts

Applications:

- Traditional refrigeration
- Cold rooms
- Water chillers

Refrigerants:

- | | | | |
|-----------|---------|---------|---------|
| • R1233zd | • R407F | • R452B | • R516A |
| • R1234yf | • R407H | • R134a | • R600 |
| • R1234ze | • R410A | • R513A | • R600a |
| • R1270 | • R422B | • R454B | • R744 |
| • R134a | • R422D | • R454C | |
| • R22 | • R438A | • R455A | |
| • R23 | • R444B | • R463A | |
| • R290 | • R448A | • R507 | |
| • R32 | • R449A | • R513A | |
| • R404A | • R449B | • R513B | |
| • R407A | • R450A | • R515A | |
| • R407C | • R452A | • R515B | |

Benefit:

- Precise control of liquid injection
- The AKV 10P/10PS valves cover a capacity range from 0.2 - 12.5 kW / 0.06 - 3.55 TR (404A / R507) and are divided into 8 capacity ranges
- Supports variety of refrigerants
- Solenoid tight shut-off
- Fully serviceable valve
- Superior valve technology that provides soft pulse operation
- The AKV 10P/10PS valve are supplied as a parts programme, as follows:
 - Separate valve incl. exchangeable orifice
 - Separate coil

Technical data and ordering

AKV 10P / AKV 10PS

Direct operated Valve

	Direct operated Valve	Servo operated Valve
Valve type	AKV 10P0 to AKV 10P7	AKV 10PS4 to AKV 10PS7
Working principle	PWM (Pulse-width modulation)	PWM (Pulse-width modulation)
Recommended period of cycle time	6 Seconds	6 Seconds
Regulation range (Capacity range)	10 - 100%	10 - 100%
Connection type	Solder	Solder
Evaporating temperature	-60 - 60°C	-60 - 60°C
Ambient temperature	-50 - 50°C	-50 - 50°C
MOPD, AKV 10P0 to AKV 10P6	35 bar / 508 psig	35 bar / 508 psig
MOPD, AKV 10P7	18 bar / 261 psi	18 bar / 261 psi
Min. OPD, AKV 10P0 to AKV 10P7	0 bar / 0 psi	0.1 bar / 1.45 psi
Filter, replaceable	Internal 100 µm	Internal 53 µm
Max. working pressure	90 barg / 1305 psig	90 barg / 1305 psig
MAP (Max. Abnormal Pressure)	1305 psig	1305 psig
COT (Continuous Operation Temperature)	60°C	60°C

Note:

- 1) It is recommended to selected Servo operated AKV 10PS valves for those application where higher MOPD (with low coil power) and high dampening is required.
- 2) Recommended Danfoss Filter ELIMINATOR® Hermetic filter drier, type DML / DMSC

Technical data and ordering

AKV 10P / AKV 10PS

AKV 10P - Rated capacity

Valve type / orifice no.	R744 ²⁾		R404A / R507 ¹⁾	R448A	R449A	R452A	K _v Value	Connection size Solder ODF / ODF	Code no. Single pack
	Refrig.	Freezing							
	[kW]	[kW]					[kW]	[kW]	
AKV 10P0	0.44	0.69	0.21	0.32	0.31	0.25	0.003	3/8 × 1/2	068F5210
AKV 10P1	1.17	1.84	0.8	0.95	0.93	0.73	0.09	3/8 × 1/2	068F5211
AKV 10P2	2.06	3.25	1.3	1.68	1.64	1.29	0.016	3/8 × 1/2	068F5212
AKV 10P3	3.14	4.97	2.0	2.57	2.51	1.98	0.024	3/8 × 1/2	068F5213
AKV 10P4	6.10	9.64	3.1	4.99	4.88	3.84	0.046	3/8 × 1/2	068F5214
AKV 10P5	8.49	13.4	4.9	6.95	6.79	5.35	0.064	3/8 × 1/2	068F5215
AKV 10P6	15.1	23.9	7.8	12.38	12.1	9.54	0.114	3/8 × 1/2	068F5216
AKV 10P7	24.6	39.3	12.5	20.07	19.63	15.47	0.185	1/2 × 5/8	068F5217

Note: It is recommended to selected Servo operated AKV 10PS valves for those application where higher MOPD (with low coil power) and high dampening is required.

AKV 10PS - Rated capacity

Valve type / orifice no.	R744 ²⁾		R404A / R507 ¹⁾	R448A	R449A	R452A	K _v Value	Connection size Solder ODF / ODF	Code no. Single pack
	Refrig.	Freezing							
	[kW]	[kW]					[kW]	[kW]	
AKV 10PS4	6.10	9.64	3.1	4.997	4.88	3.84	0.046	3/8 × 1/2	068F4044
AKV 10PS5	8.49	13.4	4.9	6.95	6.79	5.35	0.064	3/8 × 1/2	068F4045
AKV 10PS6	15.1	23.9	7.8	12.38	12.1	9.54	0.114	3/8 × 1/2	068F4046
AKV 10PS7	24.6	39.3	12.5	20.07	19.63	15.47	0.185	1/2 × 5/8	068F4047

¹⁾ Rated capacities are based on:

Condensing temperature t_c = 38°C / 100°F

Liquid temperature t_l = 37°C / 98°F

Evaporating temperature t_e = 4°C / 39°F

²⁾ Rated capacities are based on:

Condensing temperature t_c = 0°C / 32°F

Evaporating temperature Refrig. t_e = -10°C / 14°F

Evaporating temperature Freezing. t_e = -30°C / -22°F

Subcooling = 1°C / 1.8°F

C_v value is calculated from K_v value in above table

Spare part ordering - Single pack



Description	Code no.
Orifice kit direct operated AKV 10P0-3	068F5151
Orifice kit direct operated AKV 10P4-7	068F5152
Orifice kit servo operated AKV 10PS4-7	068F5155
Filter kit direct operated AKV 10P	068F5154
Filter kit servo operated AKV 10PS	068F5156
Armature kit direct operated AKV 10P0-7	068F5153
Armature kit servo operated AKV 10PS4-7	068F5157

Note: Old AKV 10/AKVH 10 body can be converted to AKV 10P/AKV 10PS by using the respective armature kit.

Technical data and ordering

AKV 10P / AKV 10PS

AKV 10P - Rated capacity

Coil type	Voltage	Frequency	Power consumption	Electrical connection	SKU / Code number	Picture	Application Comments
BE230CS	230	50	17	Term. box	018F6732		All range
BE230AS	230	50	12	Term. box	018F6701		AKV10P0-3 AKV10PS4-7
BG230AS	230	50	15	Term. box	018F6801		AKV10P0-3 AKV10PS4-7

AKV10 and AKVH 10 cross reference to AKV 10P and AKV 10PS

AKV Danfoss codes	Product Description	New AKV 10P (direct) code	Description	New AKV 10PS (servo) code	Description
068F1161	AKV10-1 Valve ODF-ODF 3/8-1/2	068F5211	AKV 10P1 Valve ODF-ODF 3/8-1/2	NA	NA
068F1164	AKV10-2 Valve ODF-ODF 3/8-1/2	068F512	AKV 10P2 Valve ODF-ODF 3/8-1/2	NA	NA
068F1167	AKV10-3 Valve ODF-ODF 3/8-1/2	068F5213	AKV 10P3 Valve ODF-ODF 3/8-1/2	NA	NA
068F1170	AKV10-4 Valve ODF-ODF 3/8-1/2	068F5214	AKV 10P4 Valve ODF-ODF 3/8-1/2	068F4044	AKV 10PS4 Valve ODF-ODF 3/8-1/2
068F1173	AKV10-5 Valve ODF-ODF 3/8-1/2	068F5215	AKV 10P5 Valve ODF-ODF 3/8-1/2	068F4045	AKV 10PS5 Valve ODF-ODF 3/8-1/2
068F1176	AKV10-6 Valve ODF-ODF 3/8-1/2	068F5216	AKV 10P6 Valve ODF-ODF 3/8-1/2	068F4046	AKV 10PS6 Valve ODF-ODF 3/8-1/2
068F1179	AKV10-7 Valve ODF-ODF 1/2-5/8	068F5217	AKV 10P7 Valve ODF-ODF 1/2-5/8	068F4047	AKV 10PS7 Valve ODF-ODF 3/8-1/2
068F4078	AKVH10-0 VALVE ODF 3/8-1/2	068F5210	AKV 10P0 Valve ODF-ODF 3/8-1/2	NA	NA
068F4079	AKVH10-1 VALVE ODF 3/8-1/2	068F5211	AKV 10P1 Valve ODF-ODF 3/8-1/2	NA	NA
068F4080	AKVH10-2 VALVE ODF 3/8-1/2	068F5212	AKV 10P2 Valve ODF-ODF 3/8-1/2	NA	NA
068F4081	AKVH10-3 VALVE ODF 3/8-1/2	068F5213	AKV 10P3 Valve ODF-ODF 3/8-1/2	NA	NA
068F4082	AKVH10-4 VALVE ODF 3/8-1/2	068F5214	AKV 10P4 Valve ODF-ODF 3/8-1/2	068F4044	AKV 10PS4 Valve ODF-ODF 3/8-1/2
068F4083	AKVH10-5 VALVE ODF 3/8-1/2	068F5215	AKV 10P5 Valve ODF-ODF 3/8-1/2	068F4045	AKV 10PS5 Valve ODF-ODF 3/8-1/2
068F4084	AKVH10-5 VALVE ODF 3/8-1/2	068F5216	AKV 10P6 Valve ODF-ODF 3/8-1/2	068F4046	AKV 10PS6 Valve ODF-ODF 3/8-1/2

Benefits of AKVP



AKV, Electric expansion valves

AKV are electrically operated expansion valves designed for refrigeration plants. The AKV valves are designed for use with a controller from Danfoss' range of ADAP-KOOL® controllers.

The AKV valves are supplied as a parts programme with separate valve body and coil (with terminal box, cable or DIN plug). AKV has an exchangeable orifice. Refrigerants: R744, R22 / R407C, R404A / R507, R410A, R134a, R407A, R23.

Features AKV

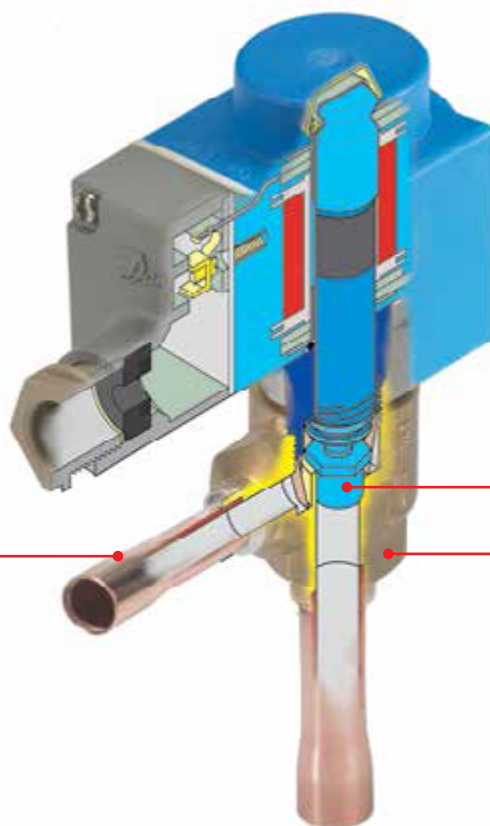
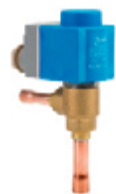

Available with ODF solder connections (AKV 15 and AKV 20 – straightway,

The orifice assembly is replaceable

Both expansion valve and solenoid valve

Facts

Applications:

- Traditional refrigeration
- Cold rooms
- water chiller

Maximum working pressure:

- AKV 10–1–6 PS / MWP = 52 bar / 754 psig
- AKV 10–7 PS / MWP = 42 bar / 610 psig
- AKV 15–1,2,3 PS / MWP = 42 bar / 610 psig
- AKV 15–4 PS / MWP = 28 bar / 400 psig
- AKV 20 PS / MWP = 28 bar / 400 psig

Refrigerants:

- R407F
- R422B
- R422D
- R448A
- R449A
- R449B
- R450A
- R452A
- R513A
- R407H
- R438A
- R463A
- R513B
- R515A
- R515B
- R134a
- R22
- R23
- R404A
- R407A
- R407C
- R410A
- R507
- R744

Capacity range:

- 0.2 – 114 TR / 0.8 – 404 kW

Benefit:

- The AKV valves are supplied as a parts programme, as follows:
- Separate valve incl. exchangeable orifice
- Separate coil
- The valve requires no adjustment

Technical data and ordering

AKV

Valve excluded coil

Valve type	Rated capacity kW				kv value	Connections	
	R22/ R407C	R134a	R404A/ R507	R407C		Solder ODF	
					m ³ /h	Inlet × outlet (in.)	Code no.
AKV 15-1	25.5	21.2	19.6	25.2	0.25	3/4 × 3/4	068F5000
AKV 15-2	40.8	33.8	31.4	40.4	0.4	3/4 × 3/4	068F5005
AKV 15-3	64.3	53.3	49.4	63.7	0.63	7/8 × 7/8	068F5010
AKV 15-4	102	84.6	78.3	101	1	1 1/8 × 1 1/8	068F5015
AKV 20-1	102	84.6	78.3	101	1	1 3/8 × 1 3/8	042H2020
AKV 20-2	163	135	125	170	1.6	1 3/8 × 1 3/8	042H2022
AKV 20-3	255	212	196	252	2.5	1 5/8 × 1 5/8	042H2024

Rated capacities are based on:

Condensing temperature $t_c = 32^\circ\text{C}$

Liquid temperature $t_l = 28^\circ\text{C}$

Evaporating temperature $t_e = 5^\circ\text{C}$

AKV

Coil



Type	Description	Code no.
Coil	240 V a.c. 12 W, 50 Hz with Terminal Box	018F6802
	230 V a.c. 10 W, 50 Hz with Terminal Box	018F6701
	230V a.c. 20W, 50Hz with Terminal Box	018F6905
	24 V a.c. 10 W, 50 Hz with Terminal Box	018F6707

ETS 6, Electric expansion valve

ETS 6 are compact and lightweight electric expansion valves. Bi-flow operation is possible for heat pump systems. The valve operation is by means of a unipolar motor, which can be controlled by a number of controllers from Danfoss or third party vendors.

With a Danfoss EKE 1A, EKE 1B, EKE 1C and EIM 336 (current drivers) and an AKS sensor, an accuracy better than ± 0.5 K can be obtained.

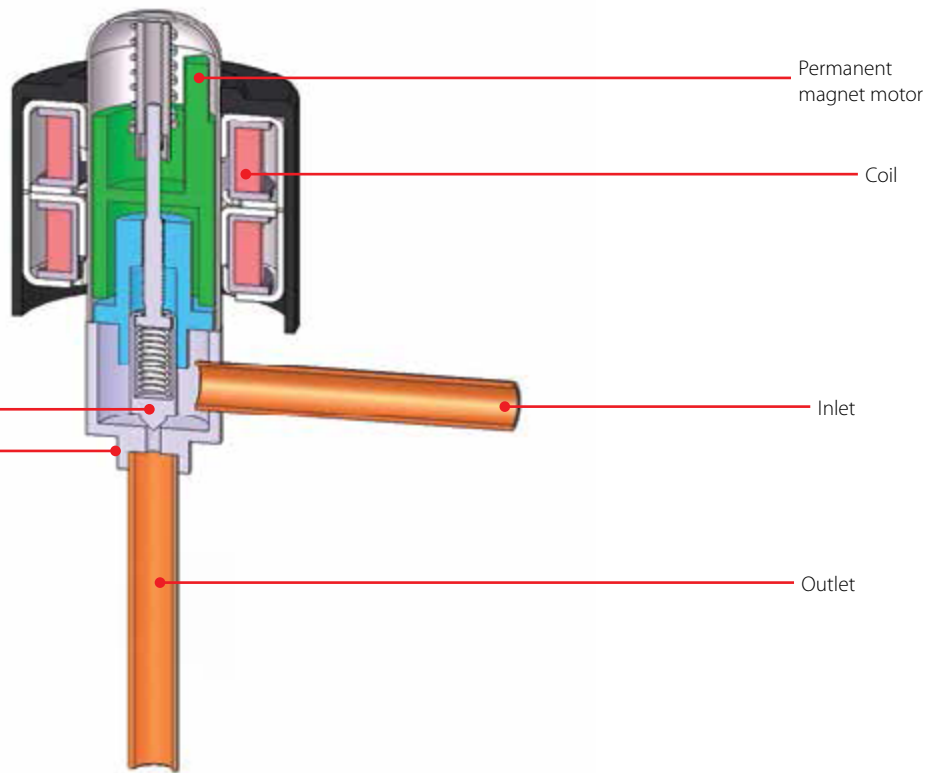

Cross section diagram of ETS 6 series
* Refers to refrigerant flow in cooling mode

Facts

Applications:

- Heat pumps
- Modular air-cooled chillers
- VRF
- Multi split
- Inverter mini split
- Bus air conditioning
- IT cooling

Maximum working pressure:

- 47 bar / 681 psig

Refrigerants:

- R134a
- R22/R407C
- R404A/R507
- R410A
- R290
- R32
- R448A
- R449A
- R452A
- R1234yf
- R407H
- R449B
- R452B
- R454A
- R454B
- R454C
- R455A
- R463A
- R513A

Capacity range:

- 0.11 – 6.56 TR / 0.42 – 23.1 kW

Benefit:

- Compact and lightweight hermetic design with removable coil
- Bi-flow operation for reversible systems
- Power saving design that enables energy efficiency with precision flow control

Technical data and ordering



ETS 6

Valve excl. coil

Type	Rated capacity (kW)					Connection (ODF X ODF)		Code no.
	R410A	R407C	R22	R134a	R404A/ R507	in.	mm	Straight away
ETS 6-10	3.1	2.7	2.6	2	1.8	-	7.94 X 7.94	034G5005
ETS 6-14	6.8	5.9	5.8	4.5	4.1	-	7.94 X 7.94	034G5015
ETS 6-18	12.1	10.6	10.3	8.1	7.3	-	6.35 X 6.35	034G5026
ETS 6-25	23	20.1	19.6	15.3	13.8	-	7.94 X 7.94	034G5035
ETS 6-32	33.9	29.6	28.8	22.5	20.3	-	7.94 X 7.94	034G5055
ETS 6-40	46	40.2	39.1	30.6	27.9	-	7.94 X 7.94	034G5065

ETS 6 rated capacity on:

Evaporating temperature t_e : 5°C (40°F), Condensing temperature t_c : 38°C (90°F), Subcooling=0°C, superheat=0°C

ETS 6

Coil



Type	Description	Code no.
Coil	12 VDC (0.26A / phase) with JST XHP-6 connector	034G5105
	12 VDC (0.26A / phase) with JST XHP-5 connector	034G5115

ETS 12C / ETS 24C / ETS 25C / ETS 50C / ETS 100C, Electric expansion valves

ETS Colibri® is an electric stepper motor valve. The valve has been designed for precise liquid injection into evaporators for air conditioning and refrigeration applications. The valves are compact, lightweight and in-line design. The valves are compact, lightweight and in-line design includes a balanced cage and slider assembly operated by the direct driven motor technology.

This ensures solenoid tight shut-off in both flow directions, thus providing smooth operation of the system. The valve incorporates a powerful bi-polar motor which precisely controls flow regulation. ETS Colibri® valves are compatible with electronic control solutions from Danfoss and other manufacturers.

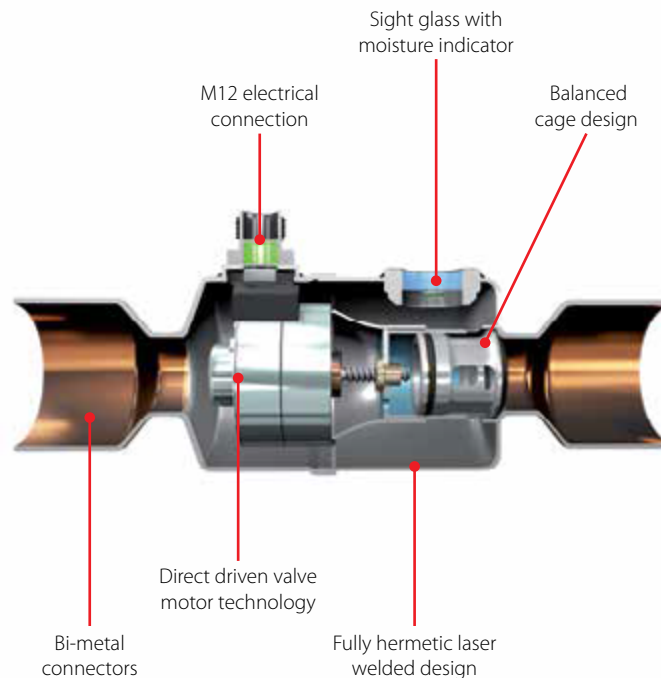
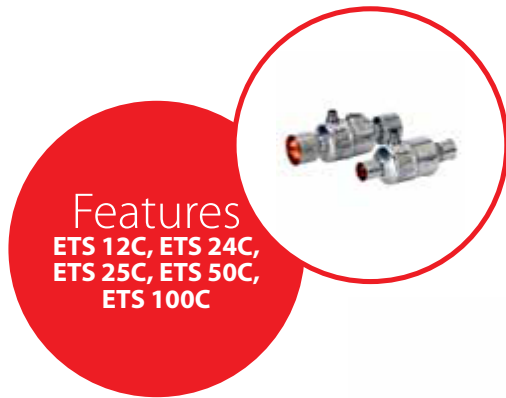

Facts

Applications:

- Air Conditioning
- Chillers, heat pumps
- Roof top and ducted split systems
- VRF and other split systems
- Close control cooling
- Refrigeration
- Cold Rooms, Food retail and Transport

Refrigerants:

- | | | | |
|-----------|---------|--------------|----------|
| • R1234yf | • R422D | • R227 | • R502 |
| • R1234ze | • R427A | • R1233zd(E) | • R512A |
| • R1270 | • R438A | • R22 | • R513B |
| • R134a | • R444B | • R407B | • R515A |
| • R23 | • R448A | • R407H | • R515B |
| • R290 | • R449A | • R413A | • R516A |
| • R32 | • R450A | • R422B | • R245fa |
| • R404A | • R452A | • R442A | • R412A |
| • R407A | • R452B | • R447A | • R500 |
| • R407C | • R454B | • R449B | |
| • R407F | • R507 | • R454A | |
| • R410A | • R513A | • R454C | |
| • R417A | • R600 | • R455A | |
| • R422A | • R600a | • R463A | |

Benefit:

- Precise control of liquid injection
- Linear Flow characteristic
- Higher MOPD and MWP
- Supports variety of refrigerants, approved for oil free applications
- Fast opening / closing time of 4 sec
- Solenoid tight shut-off
- Sight glass / moisture indicator
- Bi-metal connectors allows fast and improved brazing process
- Internal and external corrosion resistant

Technical data and ordering

ETS Colibri®

Technical data

Refrigerant oil	POE, PVE, All mineral oils, ester oils and supports oil free
Complies with PED	Yes, Fluid group 1*) and group 2.
MOPD	40 bar / 580 psi
Max. working pressure PS/MWP	50 bar(g) / 725 psi(g)
Refrigerant temperature range (measured at the inlet of the valve)	-40 – 70 °C / -40 – 158 °F
Ambient temperature	-40 – 70 °C / -40 – 158 °F
Capacity control range	10% - 100% of total opening degree
Initial opening	5% = 30 full steps
Environmental transport / storage temperature and humidity	Max. +75 °C / 167 °F, Humidity: <100% RH
Material of construction	Body: Stainless Steel / Connector: Bimetal (stainless steel and copper)
Sightglass / moisture indicator	Type N moisture indicator

*) Variants with connector size 1-1/8 in. and smaller.

Electrical data

Motor enclosure	IP67
Stepper motor type	Bi-polar - permanent magnet
Step mode	Microstepping (recommended), 2 phase full step or half step
Phase current	800 mA peak / 600 mA RMS
Holding current	No permanent holding current needed. Max. 20% permanent holding current allowed with refrigerant flow through valve. For optimal performance, driver should keep 100% current on coils 10ms after last step
Phase resistance	10 Ω ±10% at 20 °C / 68 °F
Inductance	14 mH ±25%
Duty cycle	100% possible, requiring refrigerant flow through valve. Less than 50% over 120 sec period recommended
Nominal Power consumption	7.44 W RMS at 20 °C (total, both coils)
Total number of full steps	600
Step rate	Current control driver: a. Step type: Microstep (1/4th or higher): 160 full steps/sec. recommended b. Step type: Full step or Half steps: 50 full steps/sec. recommended Emergency close : 250 full steps/sec. OEMs with 3rd party controller, please contact Danfoss.
Step translation	0.0167 mm / step
Full travel time	3.75 at 160 steps/sec
Opening stroke	10 mm / 0.4 in.
Reference position	Overdriving against the full close position
Overdriving performance	1% (6 full steps) Overdrive is recommended for optimum performance 628 steps in closing direction recommended for initialisation Overdriving in open position not recommended
Electrical connection	According to EN 61076-2-101
Compatible controllers / driver	Danfoss EKE 1A, EKE 1B, EKE 1C, MCX061V, MCX152V Certain third party controllers / drivers. Contact Danfoss for details

Installation and troubleshooting of ETS Colibri



Technical data and ordering

ETS Colibri®

Ordering - Without sight glass



Type	K _v value [m ³ /h]	C _v value [gpm]	Rated capacity ¹⁾										Connection		Code no. single pack
			R410A		R407C		R1234ze		R134a		R290		ODF × ODF (A × B)		
			[kW]	[TR]	[kW]	[TR]	[kW]	[TR]	[kW]	[TR]	[kW]	[TR]	[in]	[mm]	
ETS 12C	0.60	0.69	105	29.8	95.1	27.0	53.6	15.2	68.0	19.0	91.0	26.0	1/2 × 1/2	–	034G7500
	0.60	0.69	105	29.8	95.1	27.0	53.6	15.2	68.0	19.0	91.0	26.0	5/8 × 5/8	16 × 16	034G7501
	0.60	0.69	105	29.8	95.1	27.0	53.6	15.2	68.0	19.0	91.0	26.0	7/8 × 7/8	22 × 22	034G7502
ETS 24C	1.20	1.39	170	48.5	155	44.0	87.3	24.8	111	31.5	149	42.0	1/2 × 1/2	–	034G7900
	1.20	1.39	170	48.5	155	44.0	87.3	24.8	111	31.5	149	42.0	5/8 × 5/8	16 × 16	034G7901
	1.20	1.39	170	48.5	155	44.0	87.3	24.8	111	31.5	149	42.0	7/8 × 7/8	22 × 22	034G7902

Ordering - With sight glass



Type	K _v value [m ³ /h]	C _v value [gpm]	Rated capacity ¹⁾										Connection		Code no. single pack
			R410A		R407C		R1234ze		R134a		R290		ODF × ODF (A × B)		
			[kW]	[TR]	[kW]	[TR]	[kW]	[TR]	[kW]	[TR]	[kW]	[TR]	[in]	[mm]	
ETS 25C	1.20	1.39	170	48.5	155	44.0	87.3	24.8	111	31.5	149	42.0	7/8 × 7/8	22 × 22	034G7602
ETS 50C	2.50	2.89	323	92.0	294	83.5	166	47.1	210	59.7	282	80.0	7/8 × 7/8	22 × 22	034G7700
	2.50	2.89	323	92.0	294	83.5	166	47.1	210	59.7	282	80.0	7/8 × 1 1/8	22 × 28	034G7701
	2.50	2.89	323	92.0	294	83.5	166	47.1	210	59.7	282	80.0	1 1/8 × 1 1/8	28 × 28	034G7702
	2.50	2.89	323	92.0	294	83.5	166	47.1	210	59.7	282	80.0	1 1/8 × 1 3/8	28 × 35	034G7703
ETS 100C	5.00	5.78	635	181	577	164	325	92.5	413	117	554	157	1 1/8 × 1 1/8	28 × 28	034G7800
	5.00	5.78	635	181	577	164	325	92.5	413	117	554	157	1 1/8 × 1 3/8	28 × 35	034G7801
	5.00	5.78	635	181	577	164	325	92.5	413	117	554	157	1 3/8 × 1 3/8	35 × 35	034G7802
	5.00	5.78	635	181	577	164	325	92.5	413	117	554	157	1 5/8 × 1 5/8	–	034G7803

¹⁾ The above estimated capacities, are based on the following conditions:

Evaporating temperature t_e: 5 °C / 40 °F

Liquid temperature t_l: 28 °C / 82 °F

Condensing temperature t_c: 32 °C / 90 °F

Full stroke opening in normal flow direction.

Capacity is ± 10% in full open state in reverse flow direction.

Note: for fast and precise selection of valve, use Danfoss' CoolSelector2® software. You can download it from <http://coolselector.danfoss.com>

Ordering



Cable	Cable length (L)	Insulation	Packing format	Code no.
PVC - Black	2 m / 6.6 ft	SR-PVC	Single pack	034G7073
	8 m / 26.2 ft	SR-PVC	Single pack	034G7074

Caution: M12 angle cable is not approved for flammable applications.

Cross reference for ETS to ETS Colibri

Code	Description	Connection size (inches)	Replacement	
			Description	Code
034G4209	ETS 12.5 Electric exp. valve	1/2 × 1/2	ETS 12C	034G7500
034G4210	ETS 12.5 Electric exp. valve	5/8 × 5/8	ETS 12C	034G7501
034G4214	ETS 12.5 Electric exp. valve	5/8 × 5/8 (angle)	ETS 12C	034G7501
034G4211	ETS 12.5 Electric exp. valve	7/8 × 7/8	ETS 12C	034G7502
034G4215	ETS 12.5 Electric exp. valve	7/8 × 7/8 (angle)	ETS 12C	034G7502
034G4202	ETS 25 Electric exp. valve	5/8 × 5/8	ETS 24C	034G7902
034G4203	ETS 25 Electric exp. valve	7/8 × 7/8	ETS 25C	034G7602
034G1721	ETS 25B Electric exp. valve w. SG	7/8 × 7/8	ETS 25C	034G7602
034G1708	ETS 50 Electric exp. valve w. SG	7/8 × 7/8	ETS 50C	034G7700
034G1705	ETS 50 Electric exp. valve w. SG	7/8 × 1 1/8	ETS 50C	034G7701
034G1706	ETS 50 Electric exp. valve w. SG	1 1/8 × 1 1/8	ETS 50C	034G7702
034G1704	ETS 50 Electric exp. valve w. SG	1 1/8 × 1 3/8	ETS 50C	034G7703
034G0507	ETS 100 Electric exp. valve w. SG	1 1/8 × 1 1/8	ETS 100C	034G7801
034G0508	ETS 100 Electric exp. valve w. SG	1 3/8 × 1 3/8	ETS 100C	034G7802
034G0505	ETS 100 Electric exp. valve w. SG	1 5/8 × 1 5/8	ETS 100C	034G7803

Compatible: Danfoss EKE 1A, EKE 1B, EKE 1C, MCX061V, MCX152V

EVR version 2, Solenoid valves

EVR solenoid valves are direct or servo operated solenoid valves for liquid, suction and hot gas lines with most refrigerants, including flammable refrigerants. They are suitable for condensing units and power packs in all refrigeration, freezing and air conditioning applications and are compatible with fluorinated refrigerants R22/R407C, R134a, R404A/R507, R410A, R407A, R32, R290, R600, R600a, R1234yf, R1234ze, R404A, R407F, R152A, R448A, R449A, R452A and R450A.

EVR 2 - EVR 22 with solder connections and without manual stem are suitable for the flammable refrigerants R152A, R32, R290, R600, R600a, R1234yf and R1234ze.

The valves can be delivered as normally open or normally closed valves and with or without manual operation.

EVR valves are available with flare, solder or flange connections.

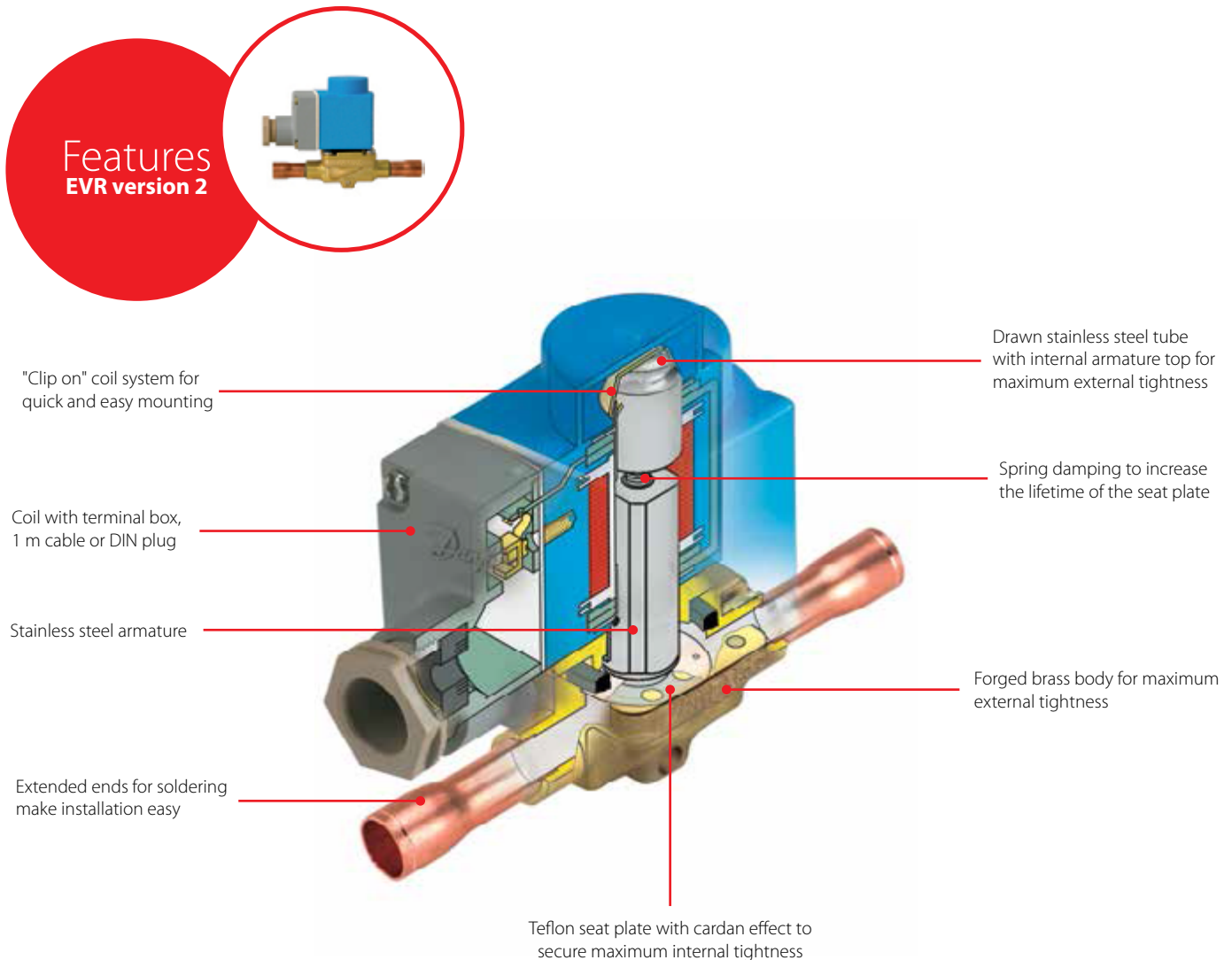

Facts

Applications:

- Traditional refrigeration
- Heat pump systems
- Air conditioning units
- Liquid coolers
- Transport refrigeration

Maximum working pressure:

- EVR solder and flare connections
45.2 bar / 655 psi

Refrigerants:

- R125
- R134a
- R404A
- R407A
- R407F
- R410A
- R417A
- R448A
- R449A
- R450A
- R452A
- R507
- R513A
- R407H
- R413A
- R422A
- R422B
- R422D
- R438A
- R447A
- R449B
- R463A
- R513B
- R515A
- R515B
- R442A
- R447B
- R512A
- R22
- R407C
- R455A

Temperature range:

- -40 – 105 °C / -40 – 221 °F

Benefit:

- High reliability and durability due to maximum internal and external tightness.
- MOPD up to 38 bar / 550 psi

Technical data and ordering

EVR version 2

Normally Closed (NC) - separate valve bodies

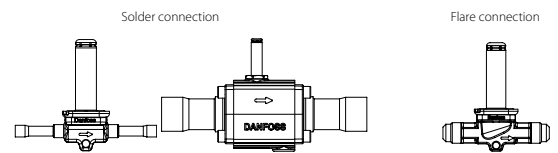

Type	Coil voltage	Connection size (in.)	Code no.		Manual operation Solder	Kv value (m ³ /h)	Code no.	
			Solder Normally Close (NC)				Flare Normally Close (NC)	
EVR 2	AC / DC	1/4	032F1201		No	0.15	032F8056	
EVR 3	AC / DC	1/4	032F1206		No	0.26	032F8107	
	AC / DC	3/8	032F1204		No	0.26	032F8116	
EVR 6	AC / DC	3/8	032L1212		No	1	032L8072	
	AC / DC	-	032L1213		No	1	-	
	AC / DC	-	032L1236		No	1	-	
	AC / DC	1/2	032L1209		No	1	032L8079	
EVR 10	AC / DC	-	032L1218		No	2.2	-	
	AC / DC	1/2	032L1217		No	2.2	032L8095	
	AC / DC	5/8	032L1214		No	2.2	032L8098	
EVR 15	AC / DC	5/8	032L1228		No	3.3	-	
	AC / DC	5/8	032L1227		Yes	3.3	032L8101	
	AC / DC	7/8	032L1225		No	3.3	-	
EVR 20	AC / DC	7/8	032L1240		No	6	-	
	AC / DC	7/8	032L1254		Yes	6	-	
	AC / DC	1 1/8	032L1244		No	6	-	
EVR 22	AC / DC	1 1/8	032L7145		No	6	-	
	AC / DC	1 3/8	032L3267		No	6	-	
EVR 25	AC / DC	1 1/8	032L2200		Yes	9.8	-	
	AC / DC	1 1/8	032L2201		No	9.8	-	
	AC / DC	1 3/8	032L2207		Yes	9.8	-	
	AC / DC	1 3/8	032L2208		No	9.8	-	
EVR 32	AC / DC	1 3/8	032L1105		Yes	16.7	-	
	AC / DC	1 3/8	032L1106		No	16.7	-	
	AC / DC	1 5/8	032L1103		Yes	16.7	-	
	AC / DC	1 5/8	032L1104		No	16.7	-	
EVR 40	AC / DC	1 5/8	032L1109		Yes	24.2	-	
	AC / DC	1 5/8	032L1110		No	24.2	-	
	AC / DC	2 1/8	032L1111		Yes	24.2	-	
	AC / DC	2 1/8	032L1112		No	24.2	-	

Technical data and ordering

Solenoid coils

BE solenoid coil with terminal box IP67

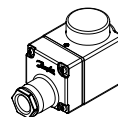

Type	Valve type	Tambient (°C)	Supply voltage (V)	Voltage variation (%)	Frequency (Hz)	Power consumption		Code no.
						W	VA	
BE012AS	EVR 2 – EVR 40 (NC) EVR 6 – EVR 22 (NO) EVRH 10 – EVRH 40 EVR EVRA EVRAT EVRS / EVRST EVM (NC)	-40T80	12	-15, +10	50	10	18	018F6706
BE024AS		-40T80	24	-15, +10	50	12	21	018F6707
BE115AS		-40T80	115	-15, +10	50	11	19	018F6711
BE230AS		-40T80	230	-15, +10	50	12	22	018F6701
BE230AS		-40T80	220	-15, +10	50	11	19	018F6701
BE240AS		-40T80	240	-15, +10	50	11	19	018F6702
BE440CS		-40T80	380 - 400	-15, +10	50	13	23	018F6703

Overview of Fluid controls

Type		EV310A 3/2-way	EV210A 2/2-way	EV220A 2/2-way	EV310B 3/2-way	EV210B 2/2-way	EV220B 6-22 2/2-way
Media	Water						
	Air and neutral gasses						
	Oil						
	Steam						
Characteristics	Dirty media				✓	✓	✓
	Long lifetime				✓	✓	✓
	Soft closing (Low waterhammer)			✓			✓
	System suitability						
	Connection	G 1/8 – G 1/4, flange 32 mm	G 1/8 – G 1/4, flange 32 mm	G 1/4 – G 2	G 1/8 – G 3/8, flange 32 mm	G 1/8 – G 1	G 1/4 – G 1
	Function	NC or NO	NC or NO	NC or NO	NC or NO	NC or NO	NC or NO
	Orifice size mm	1.2 – 2	1.2 – 3.5	6 – 50	1.5 – 3.5	1.5 – 25	6 – 22
	Pressure range, bar	0 – 20	0 – 30	0.2 – 16	0 – 20	0 – 30	0.1 – 30
	Medium temperature max.	100 °C	120 °C	100 °C	100 °C	140 °C	100 °C
	Kv value m ³ /h	0.04 – 0.08	0.04 – 0.26	1 – 32	0.08 – 0.4	0.08 – 8	0.7 – 6
Special features	Manual override option			Manual override option		Isolating diaphragm	
Approvals*	WRAS			WRAS	GL	GL, WRAS and DNV	WRAS and DNV
Material	Valve body	Brass or stainless steel	Brass or stainless steel	Brass	Brass or stainless steel	Brass or stainless steel	Brass or DZR brass
	Internal	Stainless steel	Stainless steel	Stainless steel	Stainless steel	Stainless steel	Stainless steel
	Seal material	FKM	EPDM or FKM	EPDM, NBR or FKM	FKM	EPDM or FKM	EPDM or FKM

* Only EPDM versions in Normally Closed (NC) valves are WRAS approved. GL = Germanischer Lloyd. WRAS = Water Regulations Advisory Scheme. VA = Water supply and drainage of ETA Denmark. DNV = Det Norske Veritas. SVGW = Schweizerischer Verein des Gas- und Wasserfaches.

EV220B 15-50 2/2-way	EV220B 65-100 2/2-way	EV250B 2/2-way	EV224B 2/2-way	EV225B 2/2-way	EV260B 2-way proportional	AVTA 2-way proportional	BVTS 2-way proportional	AV210
✓	✓	✓	✓	✓	✓	✓	✓	✓
✓	✓	✓	✓	✓	✓	✓	✓	✓
✓	✓	✓	✓	✓	✓			
							Back-burning and overheat protection	
G 1/2 - G 2	Flange connections: 2.5, 3 and 4"	G 3/8 - G 1	G 1/2 - G 1	G 1/4 - G 1	G 1/4 - G 3/4	G 3/8 - G 1	G 3/4	G 3/8 - G 2
NC or NO	NC	NC or NO	NC or NO	NC	NC	Thermostatic	Thermostatic	NC or NO
15 - 50	65 - 100	10 - 22	15 - 25	6 - 25	6 - 20	10 - 25	18	15 - 50
0.3 - 16	0.25 - 10	0 - 10	0.3 - 40	0.2 - 10	0.5 - 10	0 - 10	0 - 10	0 - 16
140 °C	90 °C	140 °C	60 °C	185 °C	80 °C	130 °C	110 °C	180 °C
4 - 40	50 - 130	2.5 - 7	4 - 11	0.9 - 6	0.8 - 5	1.4 - 5.5	2.6	4.5 - 74
			High pressure	IP65			Test function	Options: Manual override position indicator
GL, WRAS and DNV		WRAS	GL				TÜV	
Brass, DZR Brass or stainless steel	Cast iron	DZR Brass	Brass	DZR Brass	Brass	Brass or stainless steel	DZR brass	Gun metal or stainless steel
Stainless steel	Stainless steel	Stainless steel	Stainless steel	Stainless steel	Stainless steel	Brass or stainless steel	Stainless steel	Stainless steel
EPDM, FKM or NBR	EPDM or NBR	EPDM or FKM	NBR	PTFE and AFLAS	FKM and PTFE	EPDM or NBR	EPDM or NBR	PTFE

Media list for Danfoss Industrial Valves

Medium	Temperature/ Concentration		Brass	DZR-brass Bronze RG5
Ammonia			-	-
Brine (Potassium formate; without oxygen, closed systems)	-20 °C		✓	✓✓
Butane	20 °C		✓✓	✓✓
Chloric acid HCl			-	-
Citric acid			-	-
CO ₂			✓✓	✓✓
Compressed air			✓✓	✓✓
De-ionized water	80 °C		-	✓✓
Fresh Water	100 °C		✓✓	✓✓
Glycol	80 °C	100 %	✓	✓✓
Methane	20 °C		✓✓	✓✓
NaOH	50 °C	40 %	-	✓
Natural Gas (dry)	40 °C		✓✓	✓✓
Nitrogen (Air)			✓✓	✓✓
Oil; Animal			✓✓	✓✓
Oil; Mineral			✓✓	✓✓
Oil; Vegetable			✓✓	✓✓
Oxygen			✓	✓✓
Ozone			✓	✓✓
Propane	20 °C		✓✓	✓✓
Salt water (sea water)	20 °C	2 %	-	✓
Steam	185 °C		-	✓✓
Sulphuric acid H ₂ SO ₄			-	-
Water electrical conduction < 20 μ-siemens	60 °C		-	✓
Water electrical conduction > 500 μ-siemens	60 °C		✓✓	✓✓
Water electrical conduction between 20 and 500 μ-siemens	60 °C		✓	✓✓

✓✓	=	Suitable
✓	=	Suitable in most cases
-	=	Not recommendable

Body material			Seal material			
Stainless Steel AISI 316 / EN 1.44xx	Stainless Steel AISI 430 / EN 1.41xx armature/spring steel quality	Cast Iron	EPDM	NBR	FKM	PTFE
✓✓	✓✓	-	✓✓	✓	-	✓✓
✓✓	✓✓	✓	✓✓	✓	-	✓✓
✓✓	✓✓	✓✓	-	✓✓	✓✓	✓✓
-	-	-	-	-	✓	✓✓
✓	-	-	✓✓	✓✓	✓✓	✓✓
✓✓	✓✓	✓✓	✓✓	✓✓	✓✓	✓✓
✓✓	✓✓	✓	-	✓✓	✓✓	✓✓
✓✓	✓✓	-	✓✓	✓✓	✓	✓✓
✓✓	✓✓	✓	✓✓	✓	✓	✓✓
✓✓	✓✓	✓	✓✓	✓	-	✓✓
✓✓	✓✓	✓✓	-	✓✓	✓✓	✓✓
✓✓	✓✓	-	✓✓	-	-	✓✓
✓✓	✓✓	✓✓	-	✓	✓✓	✓✓
✓✓	✓✓	✓✓	✓✓	✓✓	✓✓	✓✓
✓✓	✓✓	✓✓	-	✓	✓✓	✓✓
✓✓	✓✓	✓✓	-	✓	✓✓	✓✓
✓✓	✓✓	✓✓	✓✓	✓	✓✓	✓✓
✓✓	✓✓	✓	✓✓	-	✓	✓✓
✓✓	✓✓	✓	✓✓	-	-	✓
✓✓	✓✓	✓✓	-	✓✓	✓✓	✓✓
✓	-	-	✓✓	✓✓	✓	✓✓
✓✓	✓✓	-	-	-	-	✓✓
-	-	-	✓	-	✓	✓✓
✓✓	✓	-	✓✓	✓✓	✓	✓✓
✓✓	✓✓	✓	✓✓	✓✓	✓✓	✓✓
✓✓	✓✓	-	✓✓	✓✓	✓	✓✓

EV220B, Solenoid valves

EV220B 15 – EV220B 50 is a universal indirect servo-operated 2/2-way solenoid valve program. Valve body in brass, dezincification resistant brass and stainless steel ensures that a broad variety of application can be covered.

Built-in pilot filter as standard, adjustable closing time and enclosures up to IP67 ensures optimal performance even under critical working conditions.

Features EV220B



Wide coil range up to IP67

High capacity across the entire pressure range

Broad temperature and material range

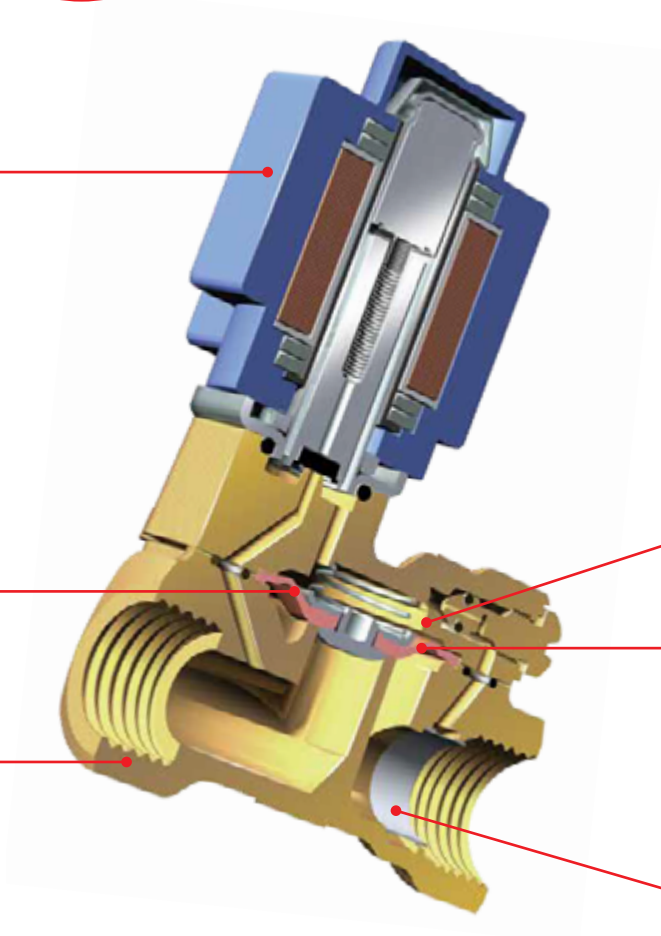

Effective against water hammer

High capacity across the entire pressure range

Insensitive to dirt

Facts

Benefit:

- 2/2-way
- Servo-operated
- DN 15 – DN 50
- Valve body available in brass, DZR brass, gun metal or stainless steel
- NC and NO versions
- ISO 228/1 or NPT thread connection (EVSI and EVSI-U)
- Built in filter for protection of pilot system
- Water hammer damped
- Adjustable closing time available
- Nominal pressure PN 16
- Wetted parts: brass, stainless steel, copper, tin, EPDM, FKM or NBR rubber

Technical data and ordering

EV220B

Servo-operated 2/2-way solenoid valves

Connection ISO228/1	Seal material	Orifice size	Kv - value (m ³ /h)	Differential pressure	Media temperature	Code no.
G ½	EPDM	10	1.5	0.1 - 20	-30 - 100	032U1251
	EPDM	12	2.5	0.3 - 10	-30 - 100	032U1256
	EPDM	15	4	0.3 - 16	-30 - 120	032U7115
	NBR	15	4	0.3 - 16	-10 - 90	032U7170
G ¾	EPDM	20	8	0.3 - 16	-30 - 120	032U7120
	NBR	20	7.5	0.3 - 16	-10 - 90	032U7171
G 1	EPDM	25	11	0.3 - 16	-30 - 120	032U7125
G 1 ¼	EPDM	32	18	0.3 - 16	-30 - 120	032U7132
G 1 ½	EPDM	40	24	0.3 - 16	-30 - 120	032U7140
G 2	EPDM	50	40	0.3 - 16	-30 - 120	032U7150

EPDM is recommended for water.

NBR is suitable for oil, water and air.

EV220B

Coils & accessories

Type	Description	Code no.
Coil	BA024A 24V 50HZ	042N7508
	BB024D 24V DC	042N7457
	BB230CS 230V 50/60HZ	018F7363
	BA024D 24V DC	042N7551
	BA240A 240V 50HZ	042N7502
Cable Plug	PG11	042N0156

EV220B

Spares

Type	Seal Material	Code no.
EV220B 15	EPDM	032U1071
EV220B 15	FKM	032U1072
EV220B 25	EPDM	032U1075

Contents for Kit:

Locking button and nut for the coil

Armature with valve plate and spring

O-ring for the armature tube

2 O-rings for the equalizing orifice

Spring and diaphragm

2 O-rings for the pilot system

Overview of Industrial switches

Pressure switches



Type

RT

BCP

KPS

CAS

KP/KPI

CS

Segments	Marine and railway equipment						
	Industrial boilers and boiler room equipment						
	Autoclaves and sterilisers						
	Water pumps and air compressors						
	Hydraulic equipment						
	Windmills						
Characteristics	Setting range	-1 – 30 bar	0.03 – 40 bar	0 – 60 bar	0 – 60 bar	-0.2 – 28 bar	2 – 20 bar
	Contact system	SPDT	SPDT	SPDT	SPDT	SPDT	TPST and SPST
	Electrical rating AC-3 Electrical rating AC-15	4 A, 400 V 3 A, 400 V	3 A, 250 V 2 A, 250 V	6 A, 400 V 4 A, 400 V	- 0.1 A, 220 V	16/ 6 A, 400 V 10/4 A, 400 V	12 A, 400 V <i>industrial engines</i>
	Electrical connection	Screw terminals	DIN plug	Screw terminals	Screw terminals	Screw terminals	Screw terminals
	Contact material	Silver or Gold	Silver or Gold	Gold	Silver	Silver or Gold	Silver
	Differential	Adjustable	Adjustable	Adjustable	Fixed	Adjustable	Adjustable
	Special approvals	Marine, TÜV	TÜV	Marine, UL	Marine	Marine	
	Degree of enclosure	IP66 or IP54	IP65	IP67	IP67	IP30, IP44 or IP55	IP43 or IP55
	Design	Box industrial	Box industrial	Box heavy duty	Box heavy duty	Box	Box
Adjustable neutral zone	Yes						

Railways and marine
Electric power and wind turbines

Industrial hydraulics, air compressors and water pumps
Boiler and boiler room equipment, sterilisers and autoclaves

Differential pressure switches				Temperature switches			
MBC	RT	CAS	MBC	RT	KPS	KP	MBC
-0.2 – 400 bar	0 – 11 bar	0.2 – 2.5 bar	0.3 – 5 bar	-60 – 300 °C	-10 – 200 °C	0 – 150 °C	-10 – 200 °C
SPDT	SPDT	SPDT	SPDT	SPDT	SPDT	SPDT	SPDT
3 A, 250 V 0.5 A, 250 V	4 A, 400 V 3 A, 400 V	- 0.1 A, 220 V	3 A, 250 V 0.5 A, 250 V	4 A, 400 V 3 A, 400 V	6 A, 400 V 4 A, 400 V	16 A, 400 V 10 A, 400 V	3 A, 250 V 0.5 A, 250 V
DIN plug	Screw terminals	Screw terminals	DIN plug	Screw terminals	Screw terminals	Screw terminals	DIN plug
Silver	Silver or Gold	Silver	Silver	Silver or Gold	Gold	Silver	Silver
Fixed	Fixed	Fixed	Fixed	Adjustable	Adjustable	Adjustable	Fixed
Marine	Marine	Marine	Marine	Marine	Marine, UL	Marine, UL	Marine
IP65	IP66	IP67	IP65	IP66 or IP54	IP67	IP30, IP44 or IP55	IP65
Compact	Box industrial	Box heavy duty	Compact	Box industrial	Box heavy duty	Box	Compact
	Yes			Yes			

KP, Pressure switch

KP pressure switches are designed to protect refrigeration systems from excessively high discharge pressures, excessively low suction pressures, to start / stop compressors or to operate fans of aircooled condensers.

The enhanced contact system for 16 A makes it possible to operate electrical motors up to 2 kW directly, without the use of contactors. KP pressure switches are available in IP30 and IP44 enclosures. Versions of KP are available for applications with HCFC and non-flammable HFC refrigerants, ammonia or hydrocarbons.

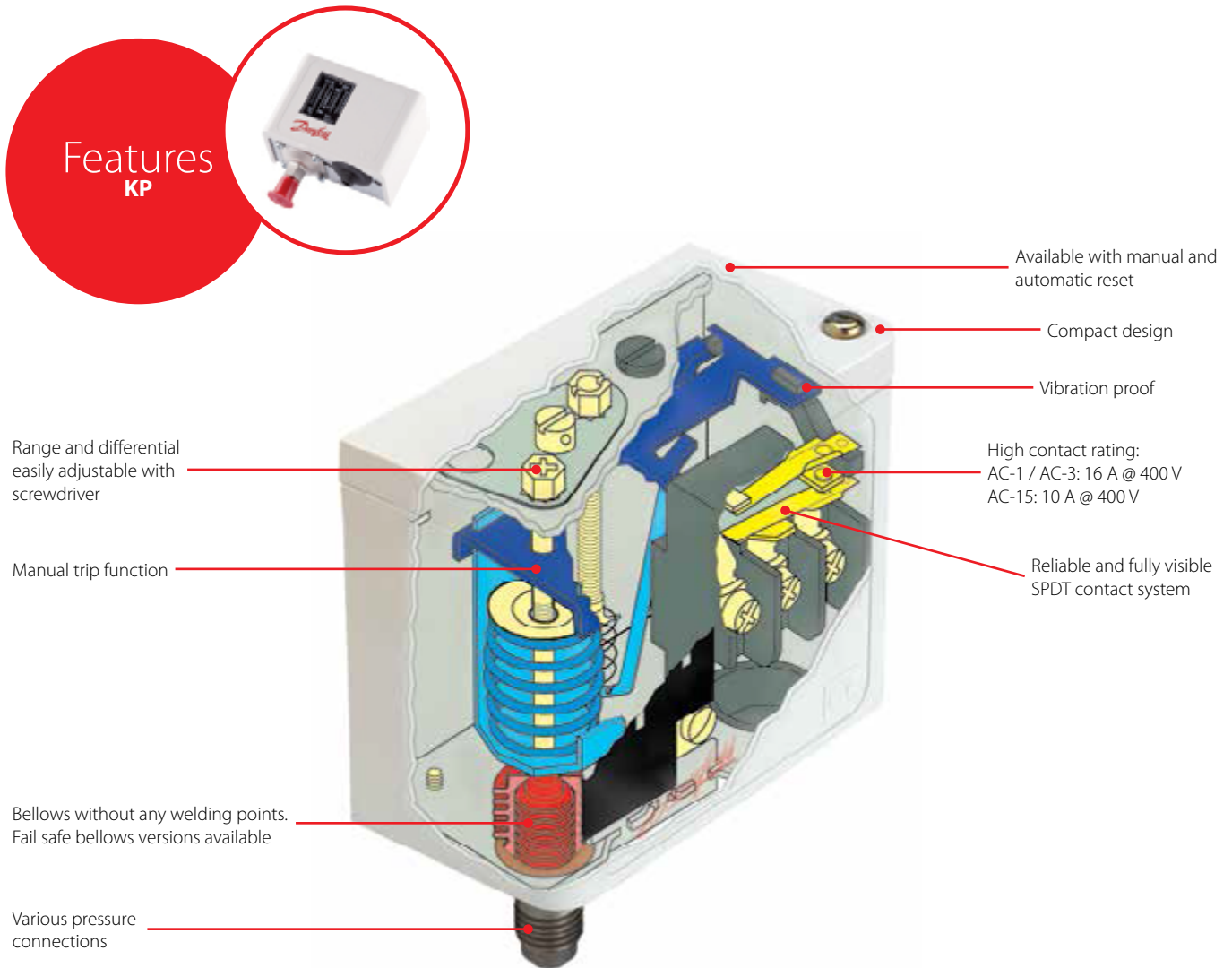

Facts

Applications:

- Food Retail
- Heavy Commercial Refrigeration
- Light Commercial Refrigeration
- Commercial Air Conditioning
- Food Processing
- Storage

Refrigerants:

- R All HCFC and non-flammable HFC refrigerants

Working range:

- -0.9 – 46.5 bar / -1.3 – 674 psi

Benefit:

- High reliability both electrically and mechanically-a KP switch can be connected directly to a single-phase AC motor of up to approximately 2 kW or installed in the control circuit of DC motors and large AC motors
- Versions with IP30 enclosure rating can be updated to IP44 or IP55 enclosure rating using top plate (IP44) or IP55 enclosure (IP55), available as accessories

Technical data and ordering

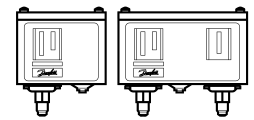

KP

Pressure Control for Fluorinated refrigerants

Pressure	Type	Low pressure (LP)		High pressure (HP)		Reset		Contact system	Code no.
		Regulating range (bar)	Differential Δp (bar)	Regulating range (bar)	Differential Δp (bar)	Low pressure (LP)	High pressure (HP)		1/4 in. 6 mm Flare
Low	KP 1	-0.2 - 7.5	0.7 - 4	-	-	Aut.	-	SPDT	060-110191
Low	KP 1	-0.9 - 7	0.7	-	-	Man.	-	SPDT	060-110391
High	KP 5	-	-	8 - 32	1.8 - 6.0	-	Aut.	SPDT	060-117191
High	KP 5	-	-	8 - 32	3	-	Man.	SPDT	060-117391
Dual	KP 15	-0.2 - 7.5	0.7 - 4	8 - 32	4	Aut.	Aut.	SPDT + LP	060-124191
Dual	KP 15	-0.2 - 7.5	0.7 - 4	8 - 32	4	Aut.	Man.	SPDT + LP	060-124391
Dual	KP 15	-0.2 - 7.5	0.7 - 4	8 - 32	4	Aut.	Man.	SPDT + LP+HP	060-126491
Dual	KP 15	-0.2 - 7.5	0.7 - 4	8 - 32	4	Conv.	Conv.	SPDT + LP+HP	060-115491

KP

Parts & accessories

Type	Description	Code no.
Mounting Brackets	Wall Bracket Flat	060-105566
	Angle Bracket	060-105666
Capillary (inc 1/4" flare nuts)	1 metre capillary with flare nuts	060-019166
IP55 Enclosure	Single for KP1, KP5, KPR5	060-033066
	Double for KP15, KP17	060-035066
OEM KP Controls (including capillary and bracket)	KP1 Auto incl. capillary and angle bracket	060-110566
	KP15 A/Auto incl. capillary and angle bracket	060-000766
KPR5 HP Control (condensor fan control)	KPR5 Auto 1/4 flare	060-117466
KP6W 8- 42 bar range (CO2 & R410A)	KP6W Auto 1/4 flare 8 – 42 bar, IP44	060-519091
	KP6B Manual 1/4 flare 8 – 42 bar, IP30	060-519191

KP, Thermostat

KP thermostats are single-pole, double-throw (SPDT) temperature-operated electric switches. KP thermostats can be connected directly to a single-phase AC motor of up to approximately 2 kW or installed in the control circuit of DC motors and large AC motors.

KP thermostats are used primarily for regulation, but also for safety monitoring systems, and are available with vapour charge or with adsorption charge. With vapour charge the differential is very small. KP thermostats with adsorption charge are widely used to give frost protection.

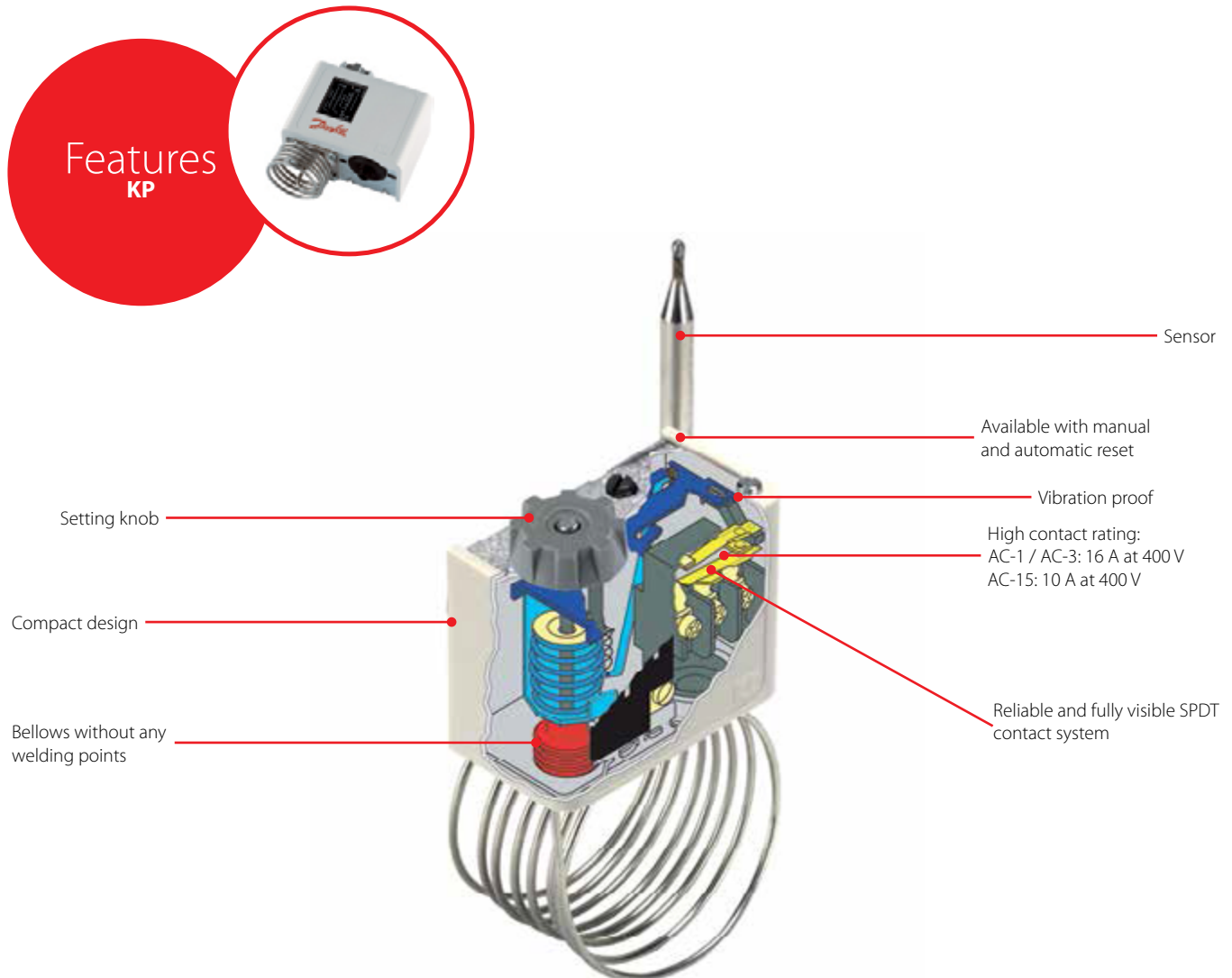

Facts

Applications:

- Frost protection
- Defrost control
- Case and Room control

Benefit:

- Available with capillary sensor, air sensor or cylindrical pocket sensor
- Different sensing elements - As experts in charging technologies Danfoss offers temperature switches that operate in a wide temperature range
- Available with vapour charge or with adsorption charge

Technical data and ordering







KP

Temperature Control - Thermostats

Charge	Type	Sensor type	Setting range (°C)	Differential Δt		Reset	Max. Sensor temp. HP (°C)	Capillary tube length (m)	Code no.
				Lowest temp. (°C)	Highest temp. (°C)				
Vapour	KP 61	A	-30 – 15	5.5 – 23	1.5 – 7	Aut.	120	2	060L110066
	KP 68	C 1	-5 – 35	4.5 – 25	1.8 – 7	Aut.	120	-	060L111166
	KP 69	B	-5 – 35	4.5 – 25	1.8 – 7	Aut.	120	2	060L111266
Absorbion	KP 71	E 2	-5 – 20	3 – 10	2.2 – 9	Aut.	80	2	060L111366
	KP 73	E 1	-25 – 15	12 – 70	8 – 25	Aut.	80	2	060L111766
	KP 73	D 1	-25 – 15	3.5 – 20	3.25 – 18	Aut.	80	2	060L114366
	KP 77	E 3	20 – 60	3.5 – 10	3.5 – 10	Aut.	130	2	060L112166

KP

Thermostat sensor types

A	B	C	D	E	F
					
Straight capillary tube	ø9.5 x 70 mm remote air coil	C1: ø40 x 30 mm air coil C2: ø25 x 67 mm air coil (integral with thermostat)	D1: ø10 x 85 mm double contact remote sensor D2: ø16 x 170 mm double contact remote sensor Note! Cannot be used in sensor pocket	E1: ø6.4 x 95 mm remote sensor E2: ø9.5 x 115 mm remote sensor E3: ø9.5 x 85 mm remote sensor	ø25x125 mm remote duct coil

MP, Differential pressure switch

MP 54 and MP 55 oil differential pressure switches are used as safety switches to protect refrigeration compressors against low lubricating oil pressure. If the oil pressure fails, the oil differential pressure switch stops the compressor after a certain time period.

MP 54 has a fixed differential pressure setting. It also incorporates a thermal time relay with a fixed release time setting. MP 55 and MP 55A have adjustable differential pressure and are available both with and without thermal time relay.

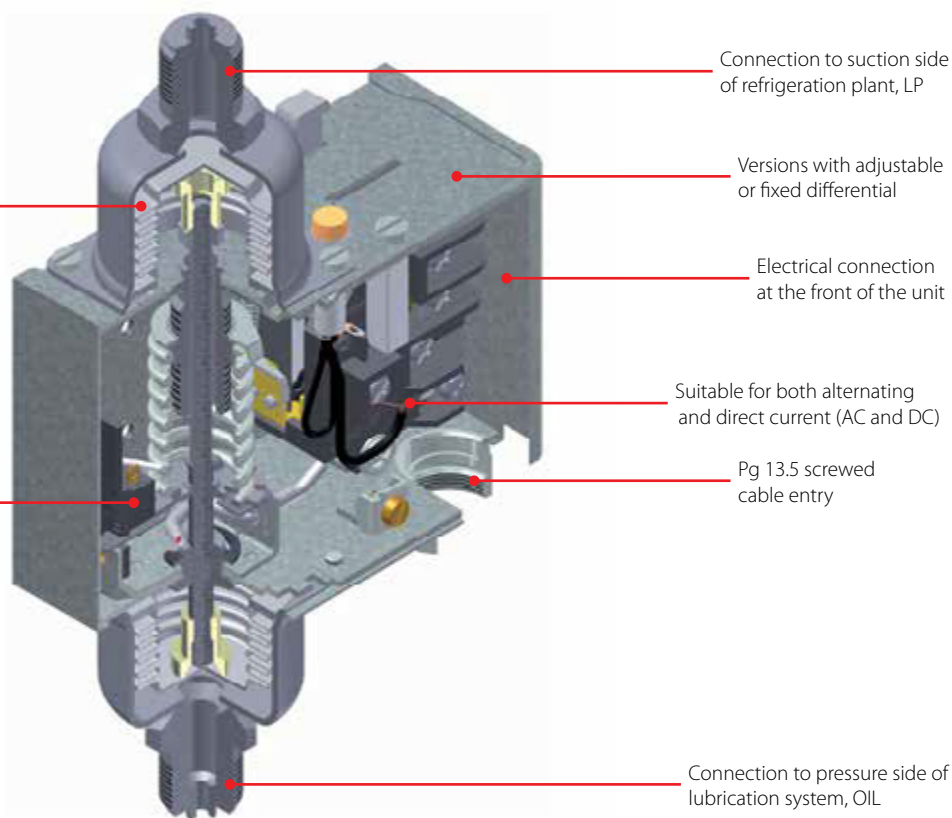
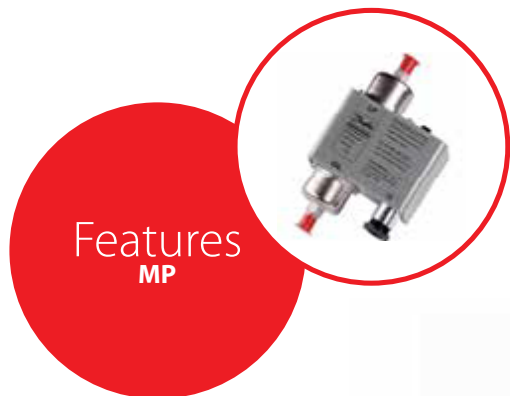

Dedicated for wide range of refrigerants

Models with different relay release time

Connection to suction side of refrigeration plant, LP

Versions with adjustable or fixed differential

Electrical connection at the front of the unit

Suitable for both alternating and direct current (AC and DC)

Pg 13.5 screwed cable entry

Connection to pressure side of lubrication system, OIL

Facts

Application:

- Food Retail
- Heavy Commercial Refrigeration
- Light Commercial Refrigeration
- Commercial Air Conditioning
- Food Processing and Storage

- Suitable for both alternating and direct current (AC and DC)
- Small contact differential
- Bellows without any welding points, which makes them stress free and completely tight
- Wide regulating range

- Screwed cable entry for cables: 6 – 14 mm diameter
- Electrical connection at the front of the unit
- Wide range of approvals - Danfoss offers a wide range of approvals suited for specific applications and geographical markets

Technical data and ordering

MP differential pressure switches for R22, R134a, R404A, R407A, R407C, R407F, R422B, R422D, R448A, R449A, R450A, R452A, R507A, R513A



Ordering

Type	Differential Δp [bar]	Operation range, LP side [bar]	Relay release time [s]	Connection type	Code no.
MP 54	0.65	-1 – 12	45	1/4 in Flare	060B016691
	0.65	-1 – 12	90	1/4 in Flare	060B016891
MP 55	0.3 – 4.5	-1 – 12	45	1/4 in Flare	060B017091
	0.3 – 4.5	-1 – 12	60	1/4 in Flare	060B017191
	0.3 – 4.5	-1 – 12	90	1/4 in Flare	060B017291
	0.3 – 4.5	-1 – 12	120	1/4 in Flare	060B017391
	0.3 – 4.5	-1 – 12	0 ²⁾	1/4 in Flare	060B029991

¹⁾ With glow lamp that remains on during normal operation.

Note: If the operational light goes out, the compressor should not run longer than the release time.

²⁾ MP without time relay.

Versions without time relay are for applications where an external time relay is required - perhaps with a different release time than the one specified.

MP differential pressure switches for R717, R22, R134a, R404A, R407A, R407C, R407F, R422B, R422D, R448A, R449A, R450A, R452A, R507A, R513A



Ordering

Type	Differential Δp [bar]	Operation range, LP side [bar]	Relay release time [s]	Connection type	Code no.
MP 55A	0.3 – 4.5	-1 – 12	45	G 3/8 A supplied with $\varnothing 6.5 / 10$ mm weld nipple	060B017491
	0.3 – 4.5	-1 – 12	60	G 3/8 A supplied with $\varnothing 6.5 / 10$ mm weld nipple	060B017591
	0.3 – 4.5	-1 – 12	90	G 3/8 A supplied with $\varnothing 6.5 / 10$ mm weld nipple	060B017691
	0.3 – 4.5	-1 – 12	0 ²⁾	G 3/8 A supplied with $\varnothing 6.5 / 10$ mm weld nipple	060B029891 ²⁾

¹⁾ With glow lamp that remains on during normal operation.

Note: If the operational light goes out, the compressor should not run longer than the release time.

²⁾ MP without time relay.

Versions without time relay are for applications where an external time relay is required - perhaps with a different release time than the one specified.

077B, Thermostat

077B thermostats have NC (Normally Closed) main contacts; i.e. they cut out the compressor current circuit on decreasing temperature. 077B thermostats are designed to operate at least 300,000 cycles at full load (6/36A and 8/40A respectively); internal quality audits

reinforced product performance by metering over 1,000,000 cycles. 077B thermostats are designed for temperature control in refrigerators and freezers and can be used as an evaporator or a room thermostat.

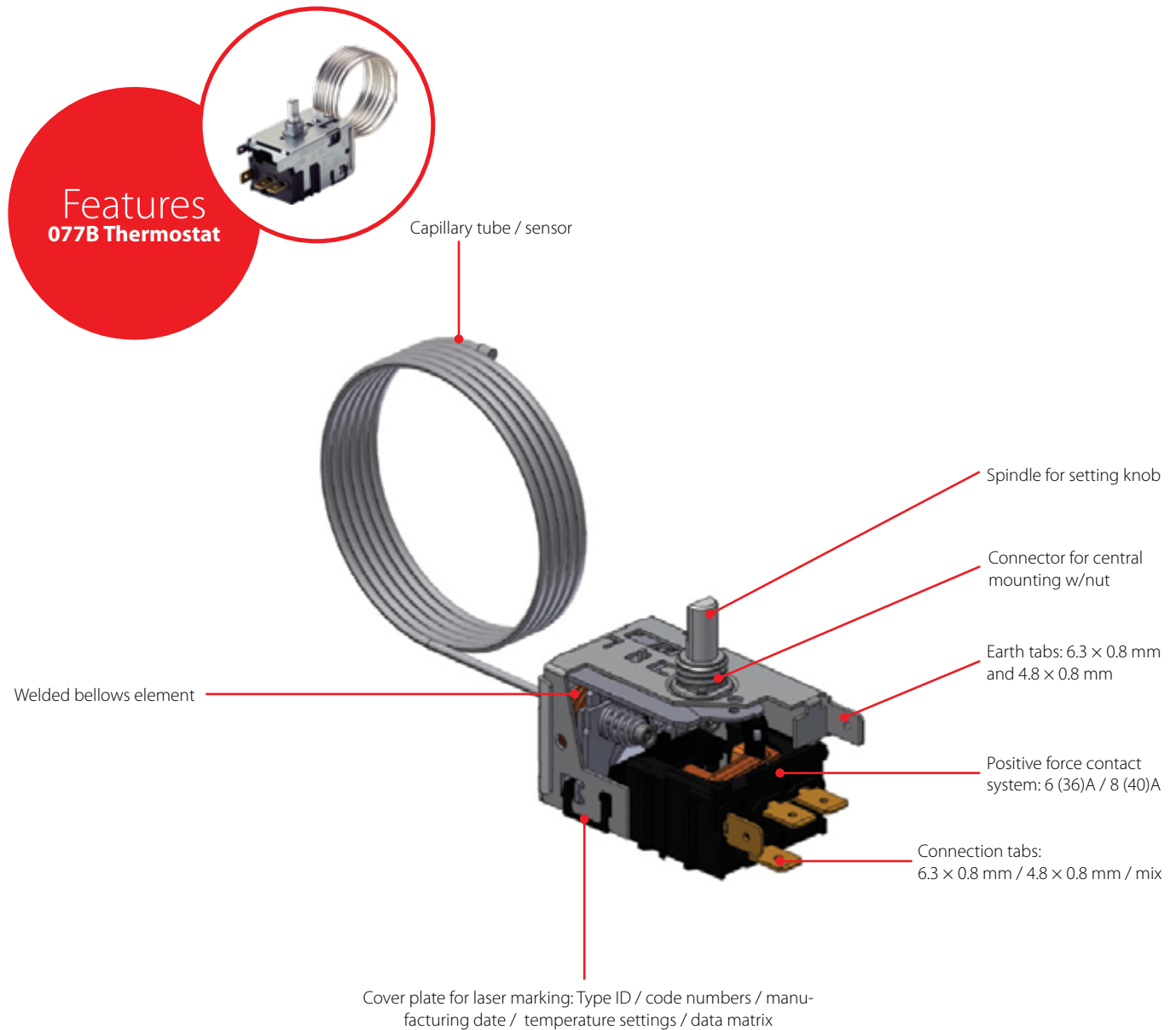

Facts

Application:

- Refrigerators
- Upright and chest freezers
- Liquid and bottle coolers
- Small commercial refrigeration

- World class quality with high CpK values that ensures a long and trouble-free lifetime
- Available with Enclosed Brake Device (EBD) for use in household appliances charged with hydrocarbon gases such as R600a or R290
- Available with a wide range of standard functions, various extra functions and accessories
- Available with 6.3 × 0.8 mm, 4.8 × 0.8 mm terminals or a combination
- Approved by recognized authorities for

specific applications and geographical markets

- Danfoss Appliance Controls are certified by Bureau Veritas in ISO14001, ISO9001 and OHSAS18001

Technical data and ordering

077B

Service thermostats

Application	No.	Temperatures (°C)				Accessories						Capillary tube length (m)	Remarks	Code no.
		Warm pos. cut-in / cut out	Cold pos. cut-in / cut out	Signal	Defrosting	Washer	Small knob	Push-button	Mounting bracket	Seal cap	Small parts			
Refrigerators	1	2 / -5.5	-13.5 / -25 *)	-	-	x	x	-	x	-	x	1.3	-	077B7001 ¹⁾
Refrigerators with pushbutton defrost	2	0 / -7.5 *)	-11 / -21	-	6	x	x	x	x	-	x	1.3	-	077B7002
Refrigerators with automatic defrost	3	3.5 / -11	3.5 / -27.5 *)	-	-	x	x	-	x	-	x	1.6	With auxillary switch	077B7003 ¹⁾
Absorption refrigerators	4	3.5 / -1 *)	-5 / -11	-	-	x	x	-	x	-	x	1.5	With auxillary switch	077B7004 ¹⁾
Ice-cream cabinets and freezers without signal	5	-7.5 / -15	-21 / -32.5 *)	-	-	-	x	-	x	x	x	2.3	-	077B7005 ¹⁾
Freezers with active signal	6	-10 / -17 *)	-24 / -34.5	-6 *)	-	-	x	-	x	x	x	2.3	With active signal	077B7006 ¹⁾
Freezers with passive signal	7	-10 / -17 *)	-24 / -34.5	-6 *)	-	-	x	-	x	x	x	2.3	With passive signal	077B7007
Bottle and liquid coolers	8	11.5 / 6 *)	-1 / -8.5	-	-	x	x	-	x	x	x	2.0	-	077B7008 ¹⁾

*) Adjustment position

¹⁾ With EBD (from January 2017)

KVR / NRD, Condensing pressure regulator / Differential pressure valve

KVR condensing pressure regulator valves can be mounted on either the gas or liquid side of the condenser in refrigeration and air conditioning systems.

They are used to maintain a constant and sufficiently high condensing pressure with systems using air-cooled condensers. KVR condensing pressure regulators can also be used with valve types NRD or KVD to assure that adequate pressure is maintained on the receiver.

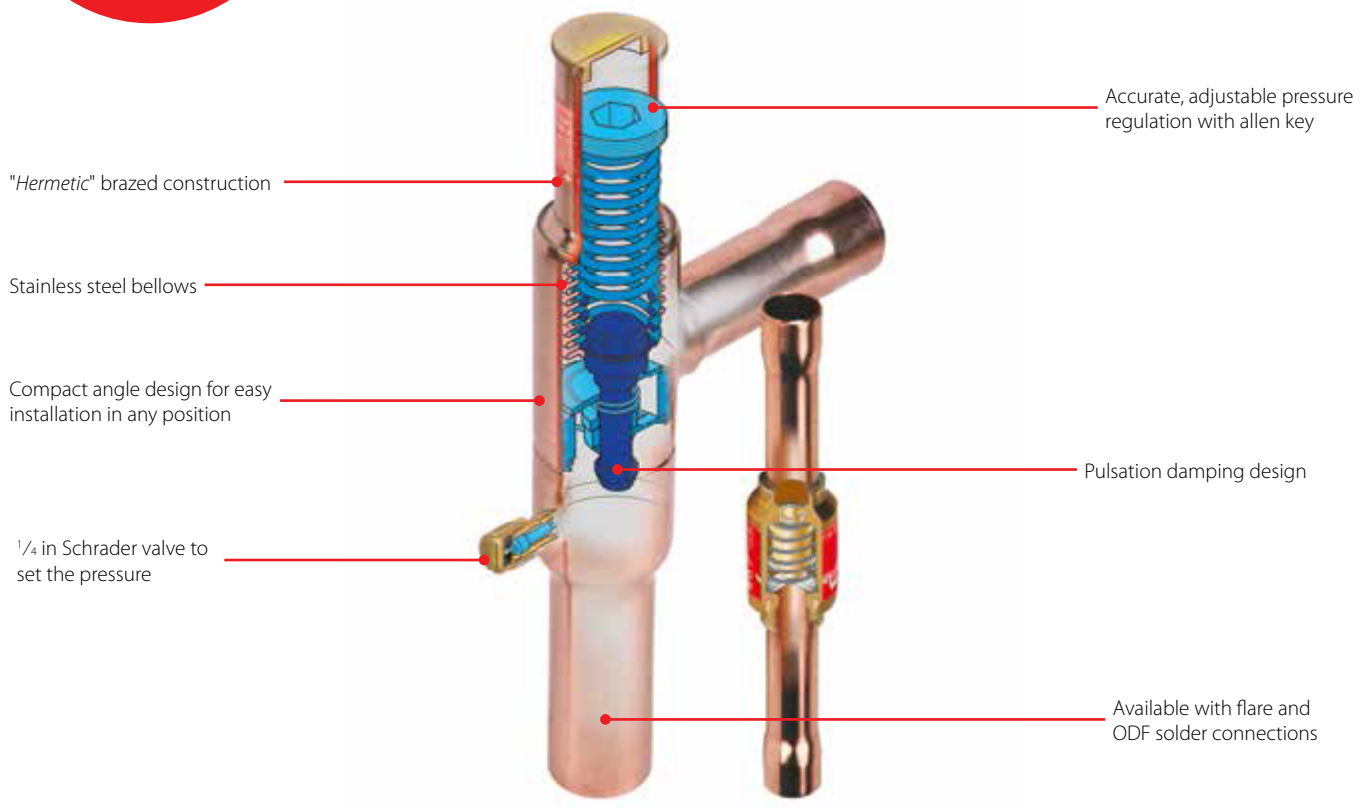

Facts

Applications:

- Traditional refrigeration
- Air conditioning units
- transport refrigeration

Maximum working pressure:

- KVR: PS / MWP = 28 bar / 406 psig
- NRD: PS / MWP = 46 bar / 667 psig

Refrigerants:

- R1270
- R134a
- R22
- R290
- R404A
- R407A
- R407C
- R407F
- R422B
- R422D
- R448A
- R449A
- R450A
- R452A
- R507A
- R513A
- R600
- R600a
- R1234ze
- R407H
- R449B
- R454C
- R455A
- R515B
- R516A
- R1234yf
- R454A

Capacity range:

- 3.4 – 40 TR / 12 - 140 kW based on liquid or hot gas

Benefit:

- The regulators are the most compact on the market
- Reliable design and very easy to adjust
- KVR can be installed either in discharge line or liquid line

Technical data and ordering

KVR / NRD

Condensing pressure regulator / Differential pressure valve

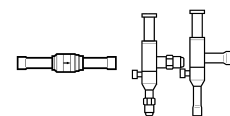

Type	Evaporator capacity								Solder, ODF connection ³⁾		Code no.
	Rated liquid capacity in kW ¹⁾				Rated hot gas capacity in kW ¹⁾				in.	mm	
	R22	R134a	R404A / R507	R407C	R22	R134a	R404A / R507	R407C			
KVR 12	50.4	47.3	36.6	54.4	13.2	11.6	12	14.3	1/2	-	034L0093
KVR 15	50.4	47.3	36.6	54.4	13.2	11.6	12	14.3	5/8	16	034L0097
KVR 22	50.4	47.3	36.6	54.4	13.2	11.6	12	14.3	7/8	22	034L0094
KVR 28	129	121	93.7	139.3	34.9	30.6	34.9	37.7	1 1/8	-	034L0095
KVR 35	129	121	93.7	139.3	34.9	30.6	34.9	37.7	1 3/8	35	034L0100
NRD	-	-	-	-	-	-	-	-	1/2	-	020B1132

1) Rated capacity is based on:

- evaporating temperature $t_e = -10\text{ }^\circ\text{C} / 14\text{ }^\circ\text{F}$

- condensing temperature $t_c = 30\text{ }^\circ\text{C} / 110\text{ }^\circ\text{F}$

- pressure drop across the valve $\Delta p = 0.2\text{ bar} / 3\text{ psi}$ for liquid capacity; $\Delta p = 0.4\text{ bar} / 6\text{ psi}$ for hot gas capacity, offset = $3\text{ bar} / 45\text{ psi}$

2) KVR are delivered without flare nuts. Separate flare nuts can be supplied: 1/2 in / 12 mm - code no. 011L1103, 3/8 in / 16 mm - code no. 011L1167. 3

3) The connection dimensions chosen must not be too small, as gas velocities in excess of 130 ft/s at the inlet of the regulator can give flow noise.

To select the product for other conditions or refrigerants, use Danfoss Coolselector®2.

Application example

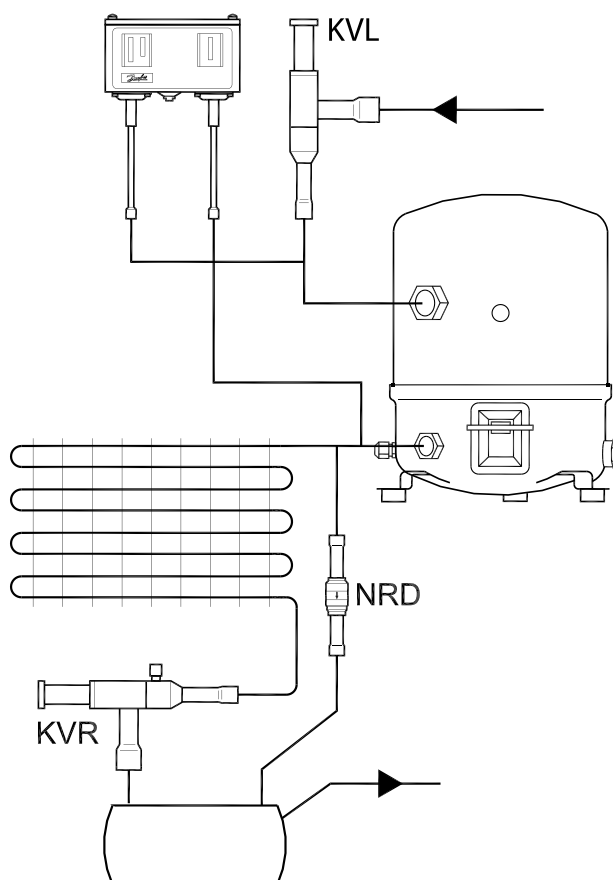

KVP, Evaporator pressure regulator

KVP evaporating pressure regulators are mounted in the suction line of refrigeration and air conditioning systems. They are used to maintain a constant pressure corresponding to a constant temperature on the evaporator.

They also protect against too low an evaporating pressure by throttling down when the pressure falls below the set value.

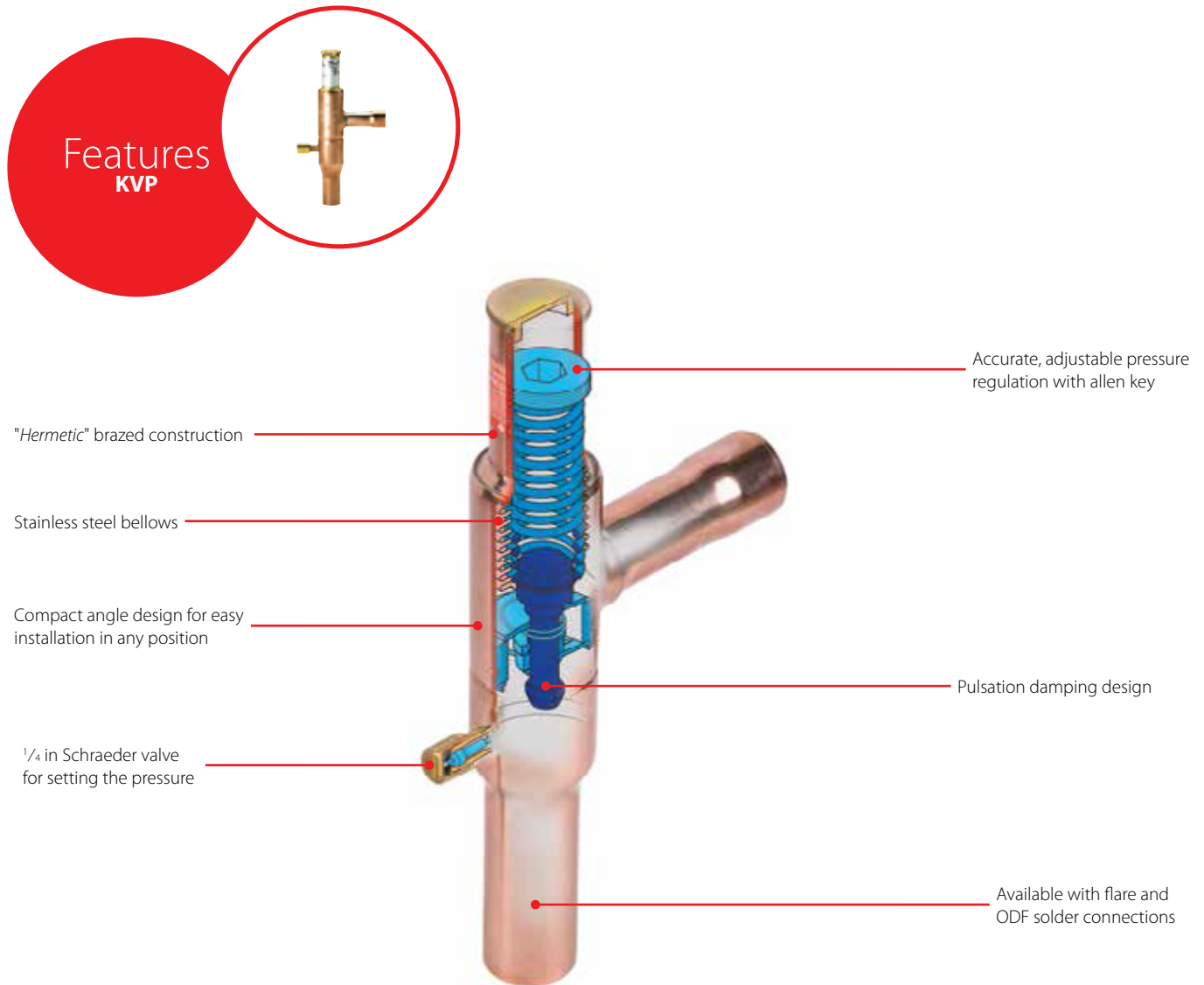

Facts

Applications:

- Traditional refrigeration
- Air conditioning units
- Cold rooms
- Display cabinets

Maximum working pressure:

- 18 bar / 260 psig

Refrigerants:

- R1270
- R134a
- R22
- R290
- R404A
- R407A
- R407C
- R407F
- R422B
- R422D
- R448A
- R449A
- R450A
- R452A
- R507A
- R513A
- R600
- R600a
- R1234ze
- R407H
- R449B
- R454C
- R455A
- R515B
- R516A
- R1234yf
- R454A

Capacity range:

- 0.9 – 2.6 TR / 2.8 – 7.9 kW

Benefit:

- Wide capacity and operating range.
- Protection against a too low evaporating pressure: the regulator closes when the pressure in the evaporator falls below the set value
- The KVP can be used to differentiate the evaporating pressures in two or more evaporators in systems with one compressor

Technical data and ordering

KVP

Evaporator pressure regulator

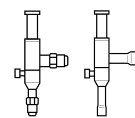

Type	Rated capacity in kW ¹⁾				Rated hot gas capacity in kW ¹⁾		Code no.	Solder, ODF connection		Code no.
	R22	R134a	R404A/R507	R407C	in.	mm		in.	mm	
KVP 12	4	2.8	3.6	3.7	1/2	12	034L0021	1/2	-	034L0023
KVP 15	4	2.8	3.6	3.7	5/8	16	034L0022	5/8	16	034L0029
KVP 22	4	2.8	3.6	3.7	-	-	-	7/8	22	034L0025
KVP 28	8.6	6.1	7.7	7.9	-	-	-	1 1/8	-	034L0026
KVP 35	8.6	6.1	7.7	7.9	-	-	-	1 3/8	35	034L0032

1) Rated capacity is the capacity of the regulator at

- Evaporating temperature $t_e = -10\text{ }^\circ\text{C}$,

- Condensing temperature $t_c = +25\text{ }^\circ\text{C}$

- Pressure drop in regulator $\Delta p = 0.2\text{ bar}$, offset = 0.6 bar

2) Supplied without flare nuts. Separate flare nuts can be supplied:

1/2 in./12 mm, code no. 011L1103, 5/8 in./16 mm, code no. 011L1167.

Application example

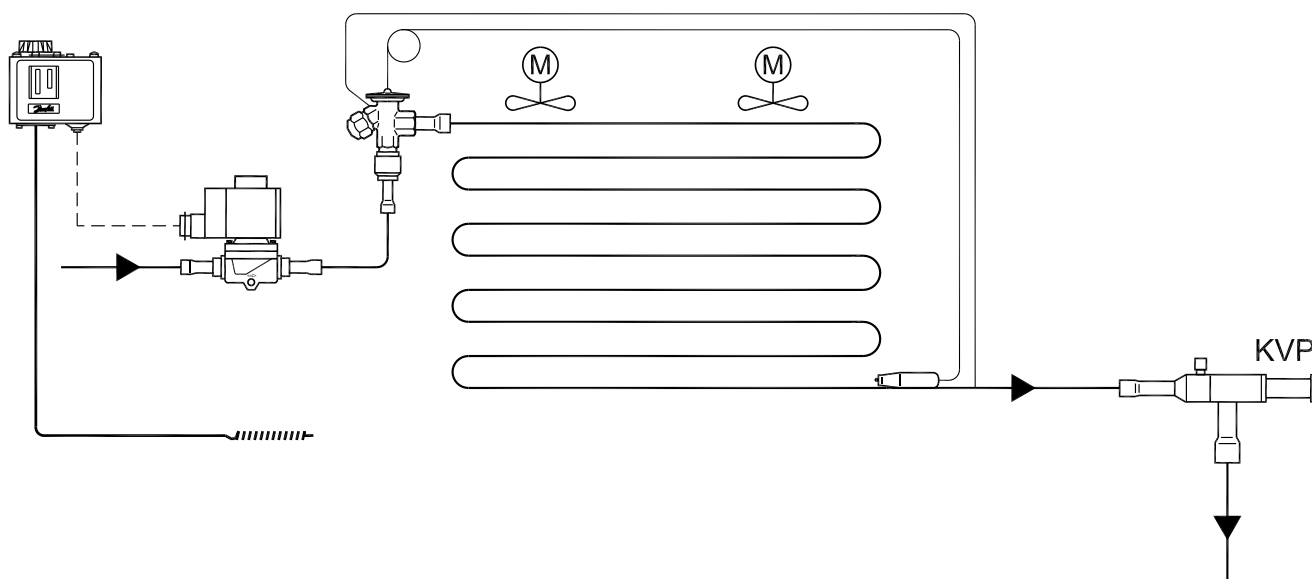

KVL, Crankcase pressure regulator

KVL crankcase pressure regulator valves are installed in the suction line ahead of the compressor.

KVL protects the compressor motor against overload during start-up after long standstill periods or after defrost periods (high pressure in evaporator).

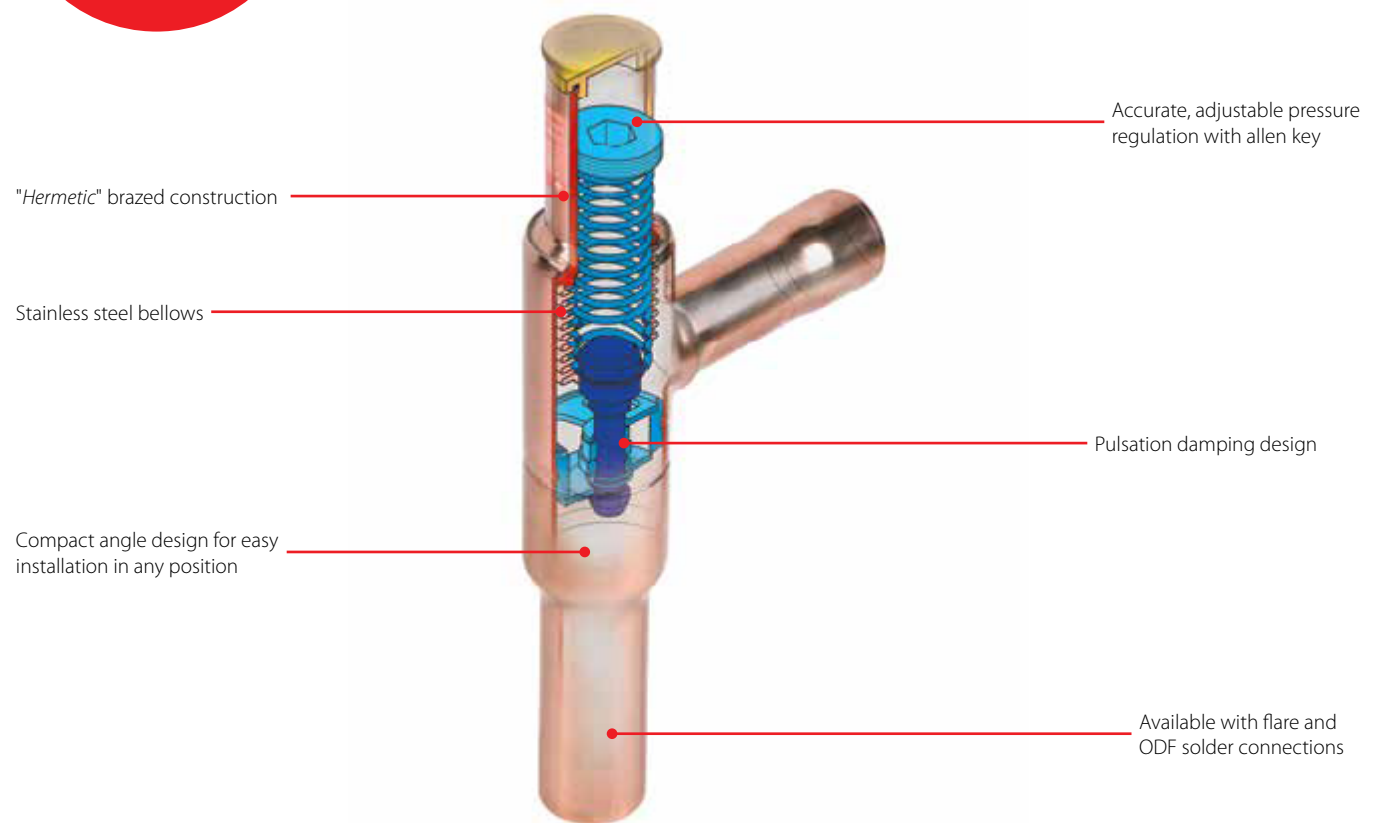

Facts

Applications:

- Traditional refrigeration
- Air conditioning units
- Transport refrigeration

Maximum working pressure:

- 18 bar / 260 psig

Refrigerants:

- R1270
- R134a
- R22
- R290
- R404A
- R407A
- R407C
- R407F
- R422B
- R422D
- R448A
- R449A
- R450A
- R452A
- R507A
- R513A
- R600
- R600a
- R1234ze
- R407H
- R449B
- R454C
- R455A
- R515B
- R516A
- R1234yf
- R454A

Capacity range:

- 5.3 – 16.4 kW

Benefit:

- Wide capacity and operating range
- Protects the compressor against electrical motor overloading

Technical data and ordering

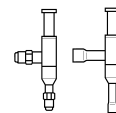

KVL

Crankcase pressure regulator

Type	Rated capacity in kW ¹⁾				Flare connection ²⁾	Code no.	Solder, ODF connection	Code no.
	R22	R134a	R404A/R507	R407C			in.	
KVL 12	7.1	5.3	6.3	6.4	1/2	034L0041	1/2	034L0043
KVL 15	7.1	5.3	6.3	6.5	5/8	034L0042	5/8	034L0049
KVL 22	7.1	5.3	6.3	6.5	-	-	7/8	034L0045
KVL 28	17.8	13.2	15.9	16.4	-	-	1 1/8	034L0046
KVL 35	17.8	13.2	15.9	16.4	-	-	1 3/8	034L0052

1) Rated capacity is the capacity of the regulator at

- Evaporating temperature $t_e = -10\text{ }^\circ\text{C}$,

- Condensing temperature $t_c = +25\text{ }^\circ\text{C}$

- Pressure drop in regulator $\Delta p = 0.2\text{ bar}$, offset = 0.6 bar

2) Supplied without flare nuts. Separate flare nuts can be supplied:

1/2 in. / 12 mm, code no. 011L1103, 5/8 in. / 16 mm, code no. 011L1167.

Application example

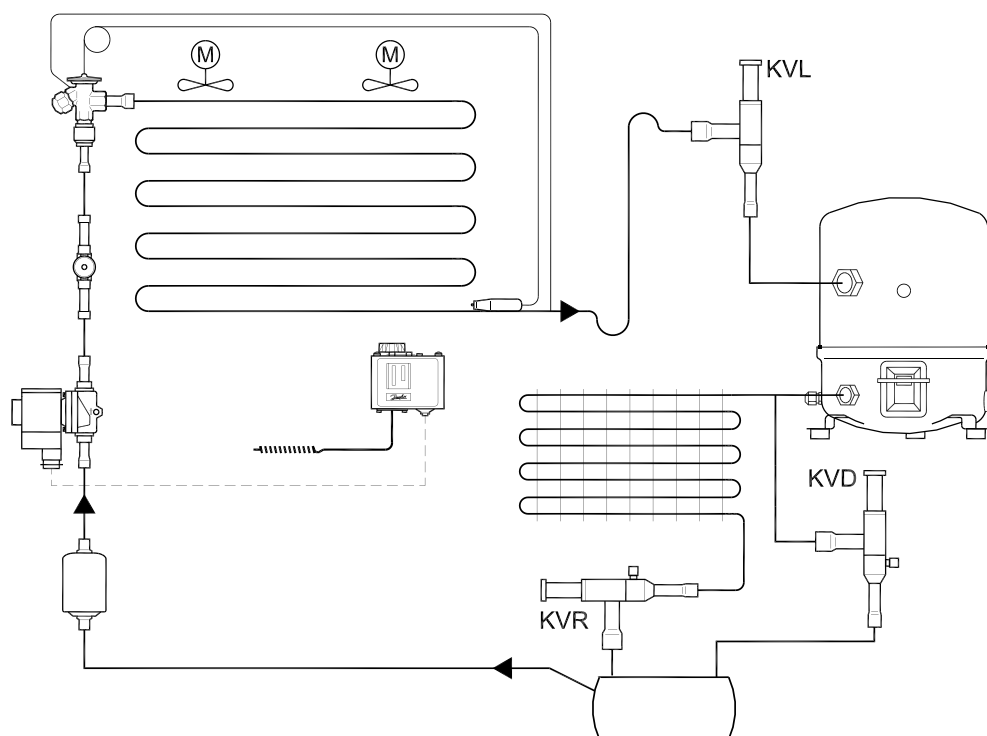

WVFX / WVO / WVS, Pressure operated water valves

WVFX, WVO and WVS pressure operated water valves are used to regulate the flow of water in refrigeration plant with water-cooled condensers in order to ensure constant proportional regulation of condensing pressure. The water valve modulates the water flow to maintain the condensing pressure at a constant level during operation.

When the refrigeration plant is stopped, the cooling water flow is shut off automatically. Media: fresh water and neutral brine. For use with aggressive media such as sea water, WVFX 15, WVFX 20 and WVFX 25 are available in stainless steel versions.

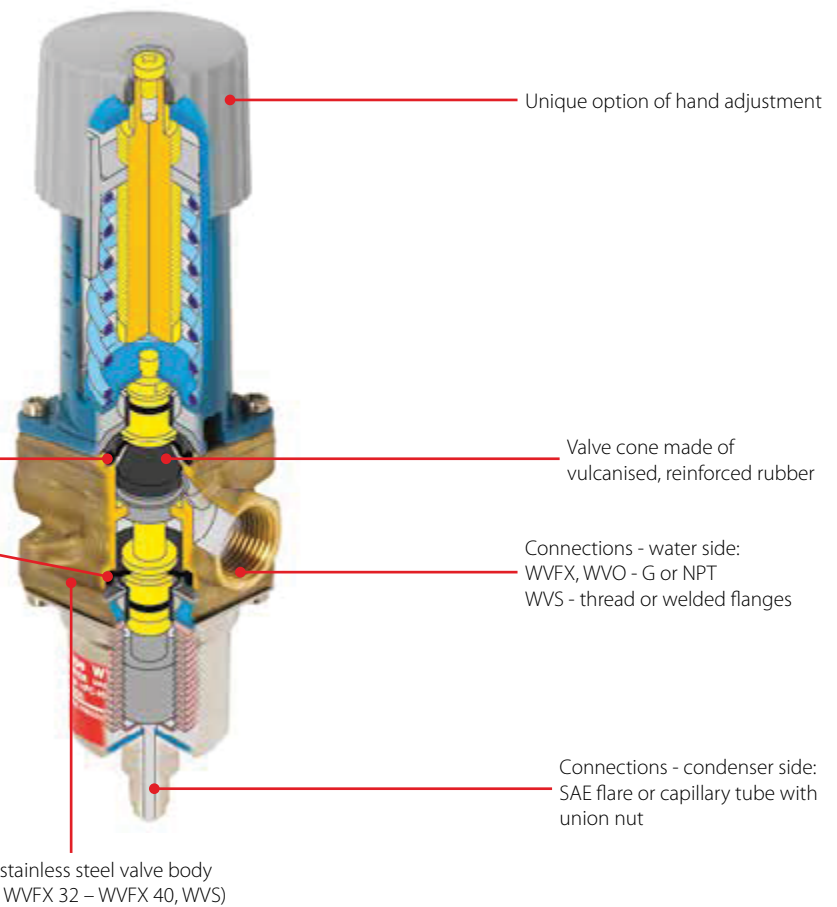

Facts

Applications:

- Traditional refrigeration
- Air conditioning units
- Other applications with water-cooled condenser
- Ice making machines
- Ice cream machines
- IT cooling
- Water chillers
- WVFX 10 – WVFX 25 can be supplied in stainless steel housing for sea water applications

- Exact pressure control - high accuracy of WVO valves up to 0.2 bar
- Reliable design - factory setting is maintained during whole life cycle
- Insensitive to dirt - fit and forget solution
- High permissible water pressure (PS) = 16 bar - can be used with water towers
- Low flow version - 0.63 m³/h (available on request)
- WVFX 10 – WVFX 40 are direct actuated valves
- WVS 32 – WVS 100 are servo-operated valves

- Very wide media temperature range: -25 – 130 °C
- Versions with capillary tube available on request
- Applicable to R22, R1270, R134a, R290, R404A, R407A, R407C, R407F, R410A ¹⁾, R448A, R449A, R450A, R452A, R507A, R513A, R600, R600a, R717 ²⁾
- ¹⁾ High pressure refrigerants version (45.2 MWP) only
- ²⁾ WVS, WVFX 10 – 25 and WVO with flare connection only; versions with capillary tube or with solder connections are not compatible with R717. WVFX 32 and WVFX 40 are not compatible with R717
- May be used in the following EX range: Category 3 (Zone 2)

Technical data and ordering

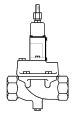

WVS - Pressure operated water valve parts programme

Type	Code no.			
	Valve body	Pilot unit ²⁾	Pilot unit for R410A and R744 (CO ₂) ²⁾	Servo spring for differential pressure range: 1 - 10 bar
WVS 32	016D5032	016D1017	016D1018	016D1327
WVS 40	016D5040	016D1017	016D1018	016D0575
WVS 50	016D5050	016D1017	016D1018	016D0576
WVS 65	016D5065	016D1017	016D1018	016D0577

¹⁾ Code numbers cover valve body, flange gaskets, flange bolts and screws for pilot valve.

²⁾ Code numbers cover control element and spring housing.

³⁾ Code numbers cover an inlet and an outlet flange.

WVFX - Pressure operated water valves, commercial applications

Ordering



Type	Connection			Range (refrigerant) [bar]	Code no.
	Water side ISO 228-1	Condenser side			
		[in]	[mm]		
WVFX 10	G 3/8	1/4	6 flare	3.5 - 16	003N1100
	G 3/8	1/4	6 flare	4.0 - 23	003N1105
WVFX 15	G 1/2	1/4	6 flare	3.5 - 16	003N2100
	G 1/2	1/4	6 flare	4.0 - 23	003N2105
WVFX 20	G 3/4	1/4	6 flare	3.5 - 16	003N3100
	G 3/4	1/4	6 flare	4.0 - 23	003N3105
	G 3/4	1/4	6 flare	15.0 - 29.0	003N3410
WVFX 25	G 1	1/4	6 flare	3.5 - 16	003N4100
	G 1	1/4	6 flare	4.0 - 23	003N4105
	G 1	1/4	6 flare	15.0 - 29.0	003N4410
WVFX 32	G 1 1/4	1/4	6 flare	4.0 - 17	003F1232
WVFX 40	G 1 1/2	1/4	6 flare	4.0 - 17	003F1240

WVFX - Pressure operated water valves, with stainless steel housing

WVFX 15	G 1/2	1/4	6 flare	4.0 - 23	003N2104
WVFX 25	G 1	1/4	6 flare	3.5 - 16	003N4101

AVTA, Thermostatic operated water valve

AVTA thermostatic operated water valves are used for proportional regulation of water flow quantity in refrigeration plant with water-cooled condensers for condensing pressure regulation purposes. AVTA valves give modulating regulation of the condensing temperature and so maintain it constant during operation.

When the refrigeration plant is stopped, the cooling water flow is shut off automatically. Media: Fresh water or neutral brine. For use with aggressive media such as sea water, special versions in stainless steel are available. AVTA opens on rising bulb temperatures.

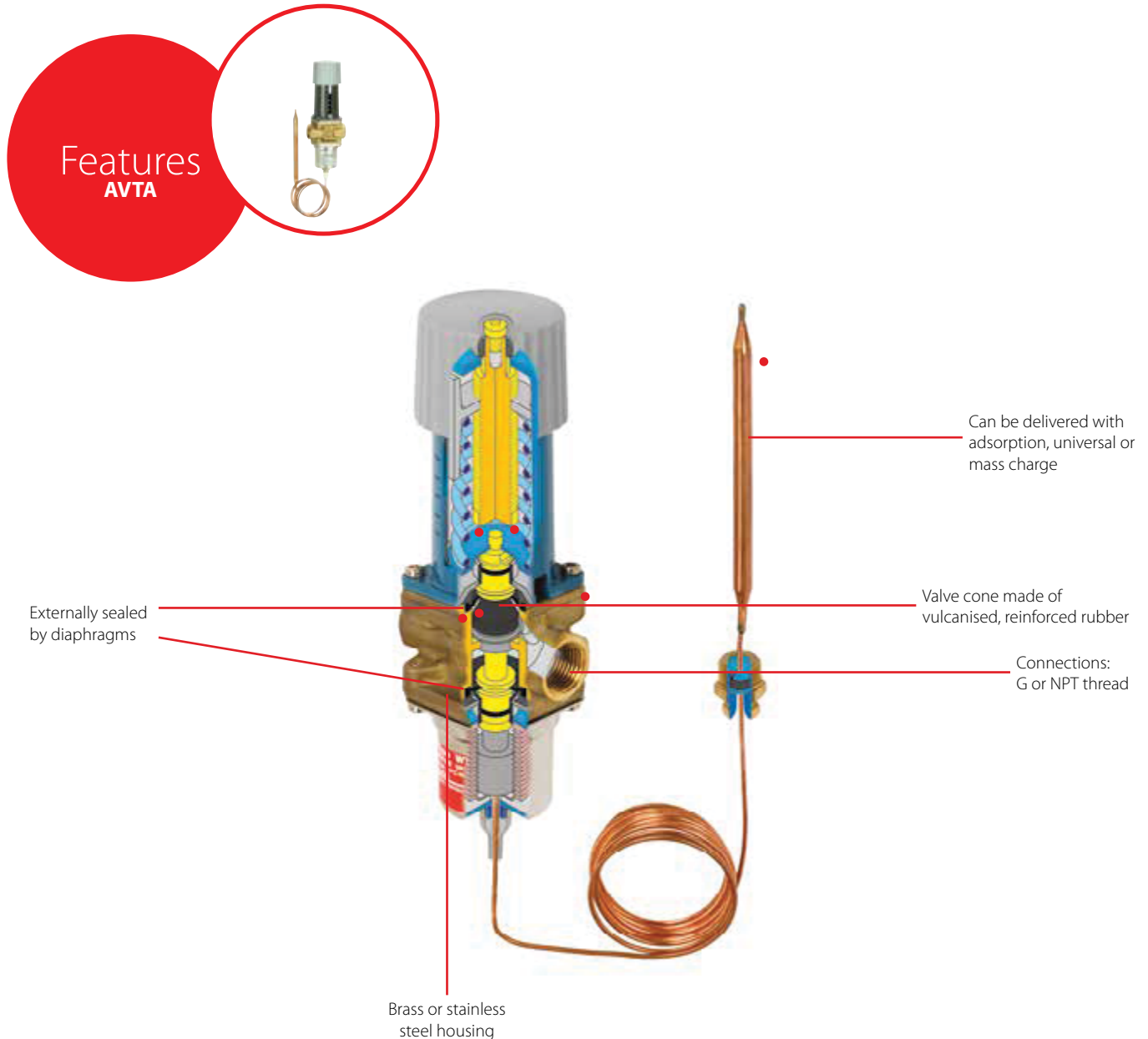

Facts

Applications:

- Traditional refrigeration with water cooled condenser
- Cooling of industrial processes

- Insensitive to dirt – fit and forget solution
- Insensitive to pressure variations
- Needs no power supply - self acting
- The valve can be placed in any position
- Operates from zero differential pressure
- Unique option of hand regulation
- Differential pressure: 0 – 10 bar
- Max. working pressure PS = 16 bar
- Max. pressure on sensor: 25 bar
- Opens on rising sensor temperature
- The regulation range is defined for the point at which the valve begins to open
- AVTA are direct actuated valves

Technical data and ordering

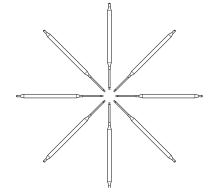

AVTA with adsorption charge (sensor $\varnothing 9.5 \times 150$ mm)

Ordering

Type	Connection ISO 228-1	Regulating range [°C]	Max. temperature sensor [°C]	K _v value at $\Delta p = 1$ bar [m ³ /h]	Capillary tube length [m]	Code no. ¹⁾
AVTA 10	G 3/8	10 – 80	130	1.4	2.3	003N1144
AVTA 15	G 1/2	10 – 80	130	1.9	2.3	003N0107
AVTA 20	G 3/4	10 – 80	130	3.4	2.3	003N0108
AVTA 25	G 1	10 – 80	130	5.5	2.3	003N0109

¹⁾ Code no. covers complete valve including capillary tube gland.

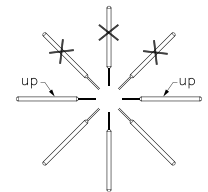

AVTA with universal charge (sensor $\varnothing 18 \times 210$ mm)

Ordering

Type	Connection ISO 228-1	Regulating range [°C]	Max. temperature sensor [°C]	K _v value at $\Delta p = 1$ bar [m ³ /h]	Capillary tube length [m]	Code no. ¹⁾
AVTA 10	G 3/8	0 – 30	57	1.4	2.0	003N1132
AVTA 15	G 1/2	0 – 30	57	1.9	2.0	003N2132
AVTA 20	G 3/4	0 – 30	57	3.4	2.0	003N3132
AVTA 25	G 1	0 – 30	57	5.5	2.0	003N4132
AVTA 10	G 3/8	25 – 65	90	1.4	2.0	003N1162
AVTA 15	G 1/2	25 – 65	90	1.9	2.0	003N2162
AVTA 20	G 3/4	25 – 65	90	3.4	2.0	003N3162
AVTA 25	G 1	25 – 65	90	5.5	2.0	003N4162
	G 1	25 – 65	90	5.5	5.0	003N4165
AVTA 15	G 1/2	50 – 90	125	1.9	2.0	003N2182
AVTA 20	G 3/4	50 – 90	125	3.4	2.0	003N3182
AVTA 25	G 1	50 – 90	125	5.5	2.0	003N4182

¹⁾ Code no. covers complete valve including capillary tube gland.

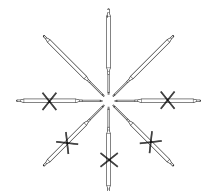

AVTA with mass charge (sensor $\varnothing 9.5 \times 180$ mm)

Ordering

Type	Connection ISO 228-1	Regulating range [°C]	Max. temperature sensor [°C]	K _v value at $\Delta p = 1$ bar [m ³ /h]	Capillary tube length [m]	Code no. ¹⁾
AVTA 15	G 1/2	25 – 65	90	1.9	2.0	003N0045
	G 1/2	25 – 65	90	1.9	2.0 (armoured)	003N0299

¹⁾ Code no. covers complete valve including capillary tube gland.

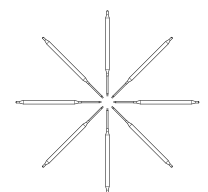

AVTA in stainless steel with adsorption charge (sensor $\varnothing 9.5 \times 150$ mm)

Ordering

Type	Connection ISO 228-1	Regulating range [°C]	Max. temperature sensor [°C]	K _v value at $\Delta p = 1$ bar [m ³ /h]	Capillary tube length [m]	Code no. ¹⁾
AVTA 15	G 1/2	10 – 80	130	1.9	2.3	003N2150
AVTA 20	G 3/4	10 – 80	130	3.4	2.3	003N3150
AVTA 25	G 1	10 – 80	130	5.5	2.3	003N4150

¹⁾ Code no. covers complete valve including capillary tube gland.

01
02
03
04
05
06
07
08
09
10
11
12
13
14
15

DML, Hermetic filter drier (Liquid line filter)

DML hermetic filter driers are optimised for refrigerants with mineral or benzene oils. The filter driers are hermetic and approved for up to 46 bar, depending on type.

The filter driers are delivered with flare or copper / copper plated steel connections.

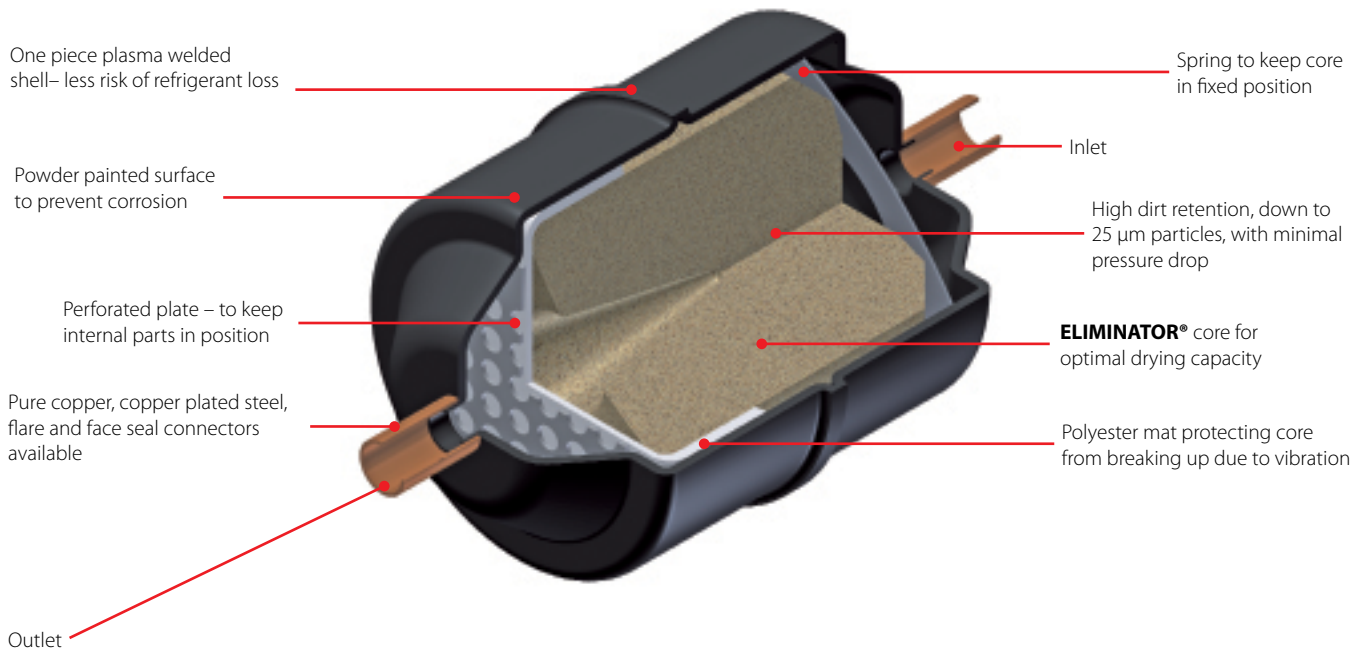

Facts

Applications:

- Traditional refrigeration
- Air conditioning units

Maximum working pressure:

- Up to 46 bar / 667 psig

Size:

- Wide range from 1.5 - 75 cubic inches

Refrigerants:

- R1234yf
- R1234ze
- R125
- R134a
- R22/R407C
- R23
- R290
- R32
- R404A
- R407A
- R407F
- R410A
- R422B
- R422D
- R438A
- R444B
- R448A
- R449A
- R449B
- R450A
- R452A
- R452B
- R454B
- R455A
- R507A
- R513A
- R600

Connections:

- Available in flare, solder

Benefit:

- Corrosion resistant powder-painted finish

Technical data and ordering

DML

Hermetic filter drier

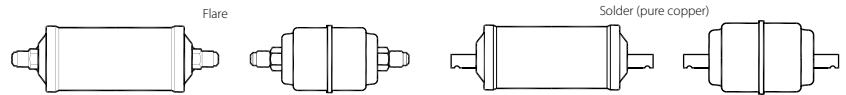

Type	Size (in.)	Size (mm)	Liquid capacity (kW)							Code no.	
			R134a	R404A	R507	R22	R407C	R410A	R32	Flare	Solder
DML 032/032s	1/4	6	6.7	5.01	4.86	7.45	7.09	7.43	10.86	023Z503591	023Z504891
DML 033/033s	3/8	10	12.85	9.86	9.57	14.46	13.84	14.67	21.4	023Z503691	023Z505091
DML 052/052s	1/4	6	7.67	5.62	5.45	8.45	8.02	8.32	12.18	023Z503791	023Z505391
DML 053/053s	3/8	10	12.87	9.81	9.52	14.44	13.8	14.58	21.28	023Z503891	023Z505491
DML 082/082s	1/4	6	7.68	5.44	5.27	8.32	7.85	8.02	11.77	023Z503991	023Z505791
DML 083/083s	3/8	10	14.19	10.98	10.66	16.03	15.37	16.35	23.85	023Z504091	023Z505891
DML 084/084s	1/2	12	28.61	21.33	20.68	31.76	30.24	31.63	46.24	023Z504191	023Z506191
DML 085/085s	5/8	16	43.81	35.32	34.33	50.47	48.71	52.83	76.81	023Z507391	023Z507291
DML 162/162s	1/4	6	7.68	5.43	5.26	8.31	7.85	8.01	11.75	023Z504291	023Z506391
DML 163/163s	3/8	10	16.33	11.18	10.82	17.41	16.33	16.43	24.16	023Z504391	023Z506491
DML 164/164s	1/2	12	32.19	23.54	22.81	35.4	33.6	34.83	50.99	023Z504491	023Z506791
DML 165/165s	5/8	16	44.64	36.59	35.59	51.82	50.16	54.83	79.63	023Z504591	023Z506891
DML 166/166s	3/4	19	45.53	37.37	36.35	52.89	51.2	56.01	81.33	023Z504691	023Z507191
DML 303/303s	3/8	10	15.7	10.56	10.2	16.59	15.52	15.48	22.79	023Z0049	023Z0067
DML 304/304s	1/2	12	32.51	25	24.26	36.63	35.06	37.19	54.26	023Z0050	023Z0068
DML 305/305s	5/8	16	45.71	36.96	35.93	52.72	50.91	55.29	80.38	023Z0051	023Z0069
DML 306/306s	3/4	19	43.73	39.89	38.95	53.22	52.49	60.57	87.22	023Z0193	023Z0070
DML 414/414s	1/2	12	33.39	26.45	25.7	38.15	36.7	39.48	57.48	023Z0109	023Z0111
DML 415/415s	5/8	16	55.48	41.84	40.58	61.92	59.08	62.11	90.74	023Z0110	023Z0112

DAS, Hermetic burn-out filter drier

DAS **ELIMINATOR**® hermetic burn-out filter driers are used in the suction line to clean up refrigeration and air conditioning systems with fluorinated refrigerants after a compressor motor burn-out.

The solid core, which is composed of 70% activated alumina and 30% Molecular Sieve, adsorbs harmful acids as well as moisture, in order to protect the new compressor against failure.

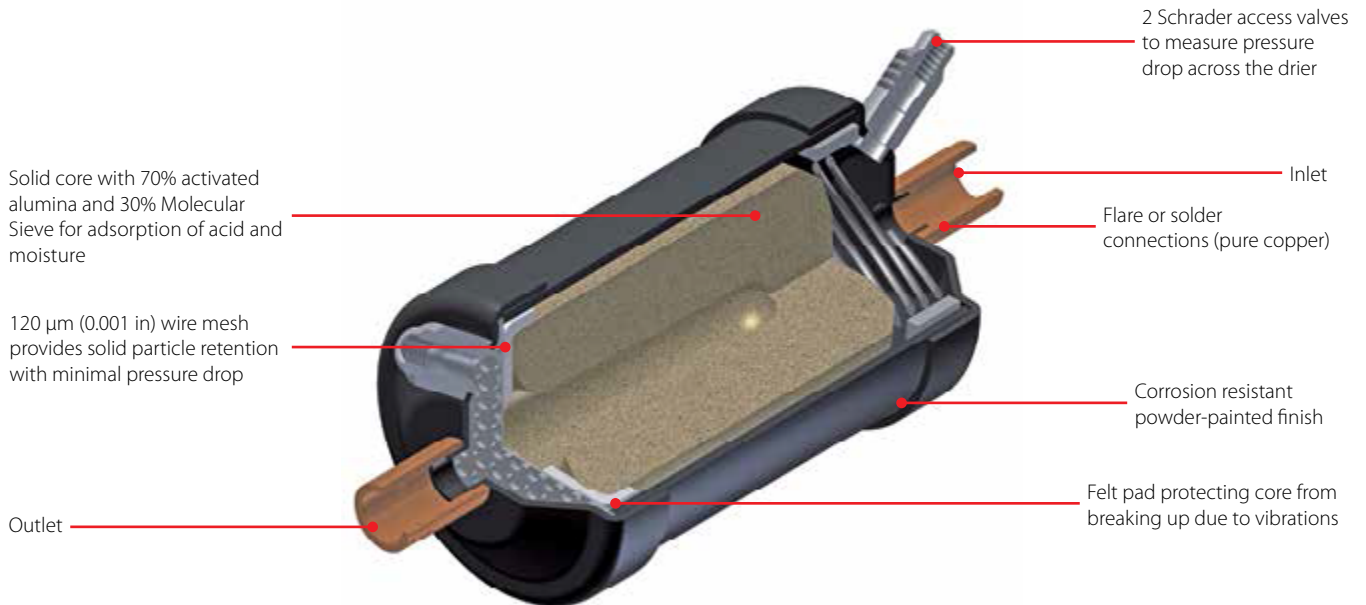

Facts

Applications:

- Traditional refrigeration
- Air conditioning units

Maximum working pressure:

- Up to 35 bar / 500 psig

Size:

- Wide range from 8 - 60 cubic inches

Refrigerants:

- R1234yf
- R1234ze
- R125
- R134a
- R22/R407C
- R23
- R290
- R32
- R404A
- R407A
- R407F
- R410A
- R422B
- R422D
- R438A
- R444B
- R448A
- R449A
- R449B
- R450A
- R452A
- R452B
- R454B
- R455A
- R507A
- R513A
- R600

Connections:

- Available in flare, solder

Benefit:

- Corrosion resistant powder-painted finish

Technical data and ordering

DAS

Hermetic burn-out filter drier

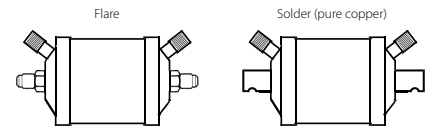

Type	Size (in.)	Rated capacity			Acid capacity (g)	Max Working Pressure PS (bar)	Code no.	
		R22/R407C/R410A	R134a	R404A / R507			Flare	Solder
DAS 083	3/8	6	3.5	4.5	3.8	35	023Z1001	023Z1003
DAS 084	1/2	10	5.5	8	3.8	35	023Z1002	023Z1004
DAS 085	5/8	14.5	9	12.5	3.8	35	-	023Z1005
DAS 086	3/4	19	11.5	16.5	3.8	35	-	023Z1006
DAS 164	1/2	10.5	6	8.5	8.6	35	023Z1007	023Z1009
DAS 165	5/8	15	9.5	13	8.6	35	023Z1008	023Z1010
DAS 166	3/4	20	12	17	8.6	35	-	023Z1011
DAS 167	7/8	22	13.5	19	8.6	35	-	023Z1012
DAS 305	5/8	18	11	15	18.2	35	-	023Z1013
DAS 306	3/4	22	14	19	18.2	35	-	023Z1014
DAS 307	7/8	26	16	22	18.2	35	-	023Z1015
DAS 309	1 1/8	31	20	27	18.2	35	-	023Z1016
DAS 417	7/8	30	18	25	24.3	35	-	023Z1017
DAS 419	1 1/8	35	22	30	24.3	35	-	023Z1018
DAS 607	7/8	20	12	17	36.5	35	-	023Z1019
DAS 609	1 1/8	-	-	-	-	35	-	023Z1020

DMB, Hermetic bi-flow filter drier

DMB **ELIMINATOR**[®] hermetic bi-flow filter drier series are for use in liquid lines on heat pumps, and have built-in check valves to ensure that refrigerant liquid flows through the filter drier from the outer side of the filter core towards the center. They ensure fast and effective adsorption of moisture as well as organic and inorganic acids, and all dirt particles are retained irrespective of flow direction.

DMB hermetic bi-flow filter driers contain a solid core consisting of 100% 3 Å Molecular Sieve, and are especially suitable for heat pumps with HFC refrigerants and polyolester oil with additives.

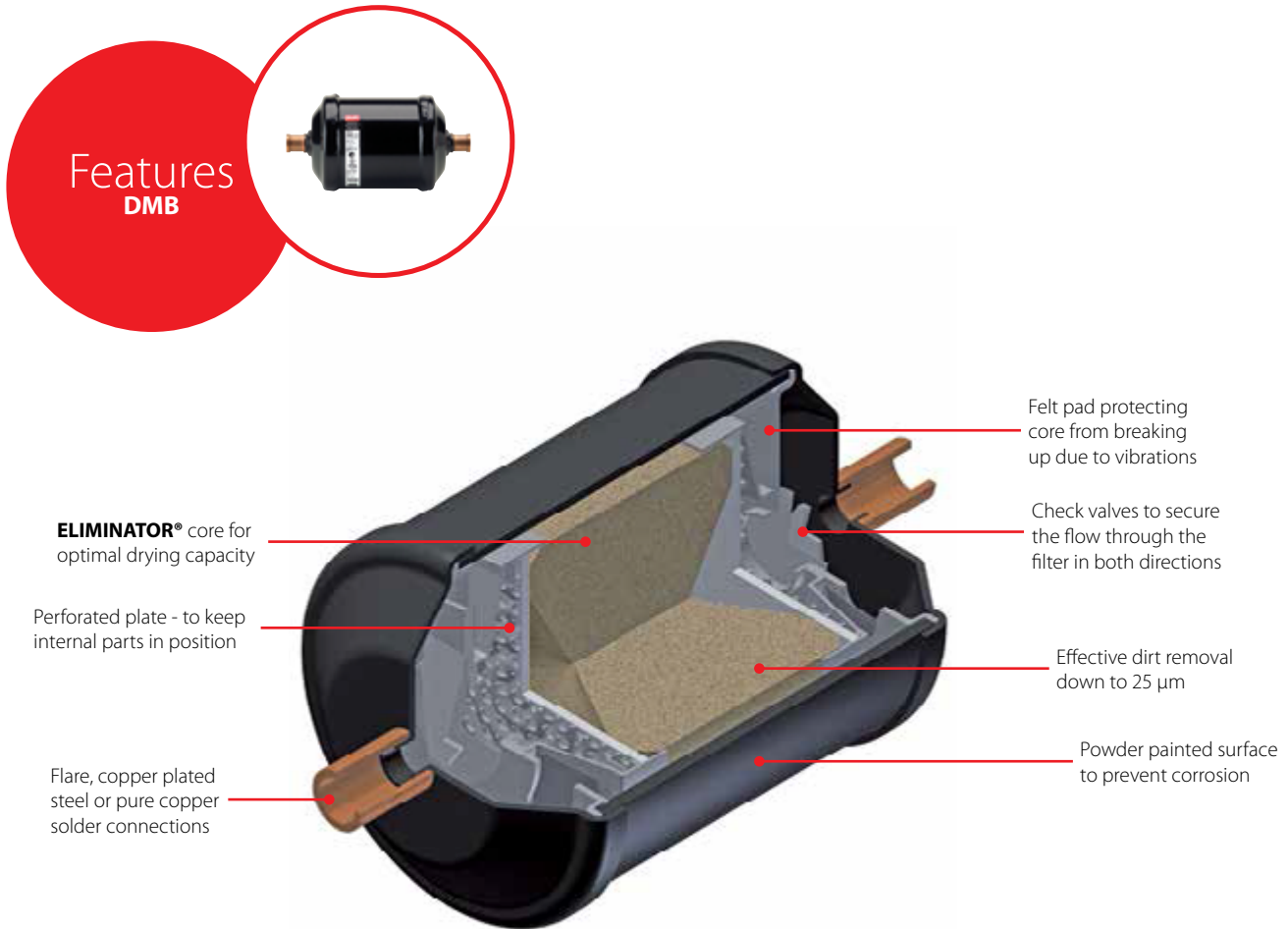

Facts

Applications:

- Traditional refrigeration
- Heat pumps
- Air conditioning units

Maximum working pressure:

- 46bar

Capacity range:

- 0.7 – 13.3 TR / 2.8 – 47 kW

Refrigerants:

- R1234yf
- R1234ze
- R125
- R134a
- R22/R407C
- R23
- R32
- R404A
- R407A
- R407F
- R410A
- R422B
- R438A
- R444B
- R448A
- R449A
- R449B
- R450A
- R452A
- R452B
- R454B
- R455A
- R507A
- R513A

Benefit:

- No dirt released by reversing the flow direction
- The check valves are not sensitive to dirt and give minimum restriction, irrespective of flow direction
- Use of hermetic bi-flow filter driers can save up to ten solder connections in heat pump systems. This reduces production costs and the number of potential leakage points

Technical data and ordering

DMB

Hermetic bi-flow filter drier

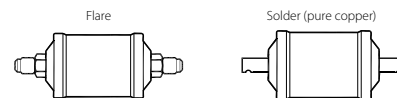

Type	Size		Liquid capacity (kW)						Code no.	
	in.	mm	R134a	R404A	R507	R22	R407C	R410A	Flare	Solder
DMB 082 / 82s	1/4	6	3.9	2.8	2.8	4.3	4.3	4.3	023Z1412	023Z1443
DMB 083 / 83s	3/8	10	7.4	5.3	5.3	8.2	8.2	8.2	023Z1411	023Z1442
DMB 084 / 84s	1/2	12	8.3	6	6	9.2	9.2	9.2	023Z1410	023Z1441
DMB 163 / 163s	3/8	10	18	13	13	20	20	20	023Z1415	023Z1446
DMB 164 / 164s	1/2	12	28	20	20	32	32	32	023Z1414	023Z1445
DMB 165 / 165s	5/8	16	37	29	29	40	40	40	023Z1413	023Z1444
DMB 304 / 304s	1/2	12	28	20	20	31	31	31	-	023Z1449
DMB 305 / 305s	5/8	16	38	28	28	42	42	42	023Z1417	023Z1448
DMB 307s	7/8	-	43	32	32	47	47	47	-	023Z1447

DCR, Filter drier with replaceable solid core

DCR **ELIMINATOR**® filter driers with replaceable solid core protect refrigeration, freezing and air conditioning systems from moisture, acids and solid particles.

Besides being able to meet the demanding requirements of high working pressure levels when operating with R410A thanks to replaceable solid cores the DCR programme offers flexibility with respect to different applications.

Core types:

- 48-DC for HFC, HCFC systems and mineral or AB oils
- 48-DM for HFC, HCFC systems and POE or PAG oils
- 48 DA for acid adsorption after burnout
- 48-F strainer for retaining dirt

Cores / inserts are ordered separately.

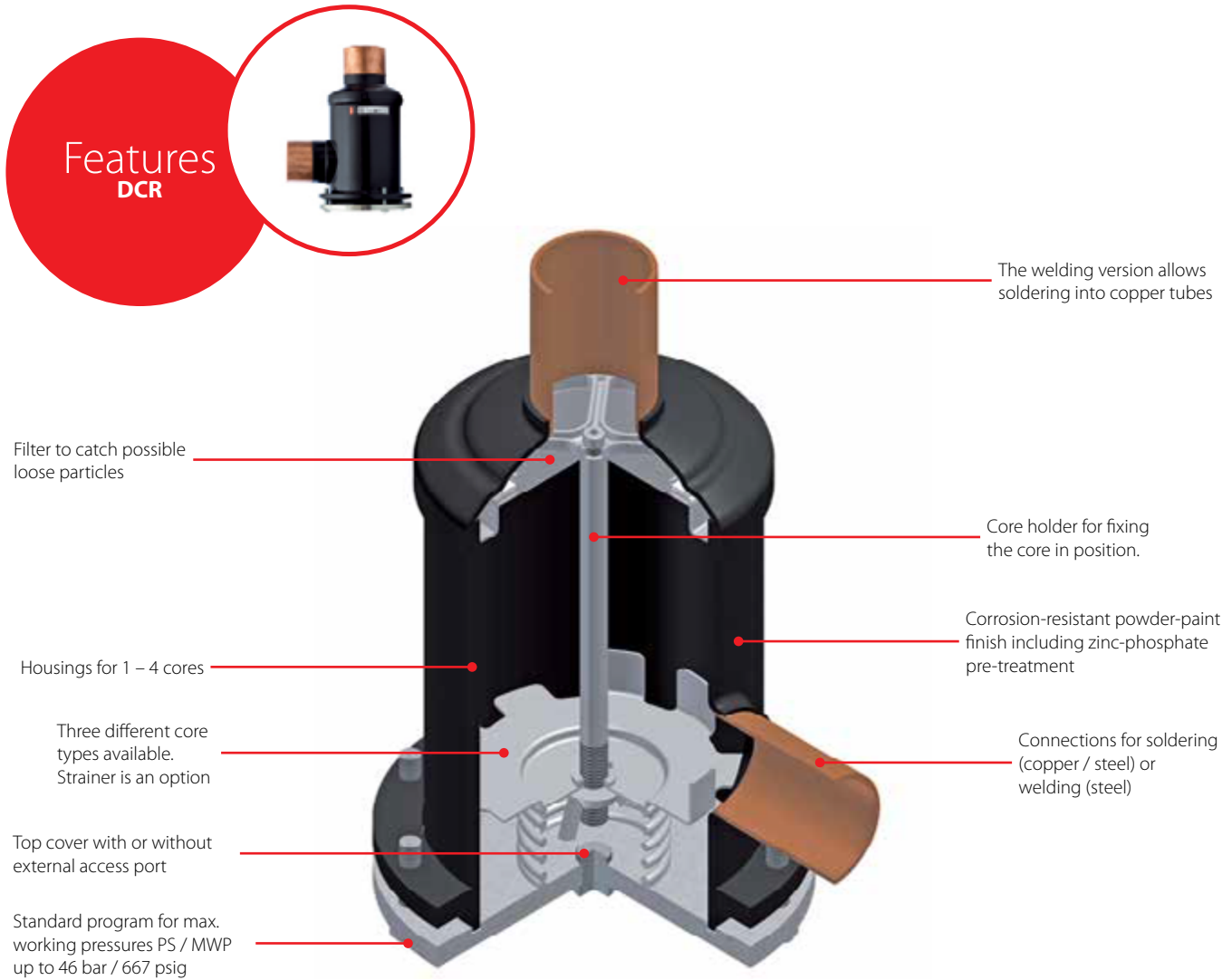

Facts

Applications:

- Traditional refrigeration
- Air conditioning units

Maximum working pressure:

- 35 / 46 bar (receiver / drier application)

Refrigerants:

- R1234ze
- R125
- R134a
- R22/R407C
- R23
- R404A
- R407A
- R407F
- R410A
- R438A
- R448A
- R449A
- R449B
- R450A
- R452A
- R507A
- R513A

Connections:

- Solder

Benefit:

- Highly efficient dirt retaining capabilities on both the suction and the liquid line

Technical data and ordering

DCR

Filter drier with replaceable solid core

Type	Number of core	Size		Max. working pressure PS (bar)	Code no.
		in.	mm		Solder
DCR 0487	1	7/8	22	46	023U7251
DCR 0489	1	7/8	22	46	023U7253
DCR 04811	1	–	28	46	023U7254
DCR 04813	1	1 1/8	–	46	023U7255
DCR 04821	1	1 3/8	35	46	023U7276
DCR 0969	2	–	42	46	023U7459
DCR 09611	2	–	42	46	023U7461
DCR 09617	2	2 5/8	–	46	023U7464
DCR 1449	3	7/8	22	35 / 46	023U7066

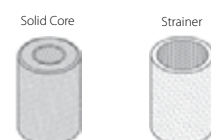

DCR

Inserts with gasket

Type	Material / Description	Code no.
48-DM solid core	100% molecular sieve	023U1392
48-DC solid core	80% molecular sieve & 20% Al3 O2	023U4381
48-DA solid core	30% molecular sieve & 70% Al3 O2	023U5381
48-F strainer	Felt-gasket, 15 µm	023U1921

SGP, Sight glass (high pressure)

SGP are sight glasses for high pressure applications (Max Working Pressure PS / MWP: 52 bar / 754 psi). SGP is available with flare, solder and socket connections, and with and without moisture indicators.

SGP N equipped with sensitive indicators that reflects a changes colour, depending on the moisture content in the refrigerant.



Reliable due to minimal dependancy on temperature

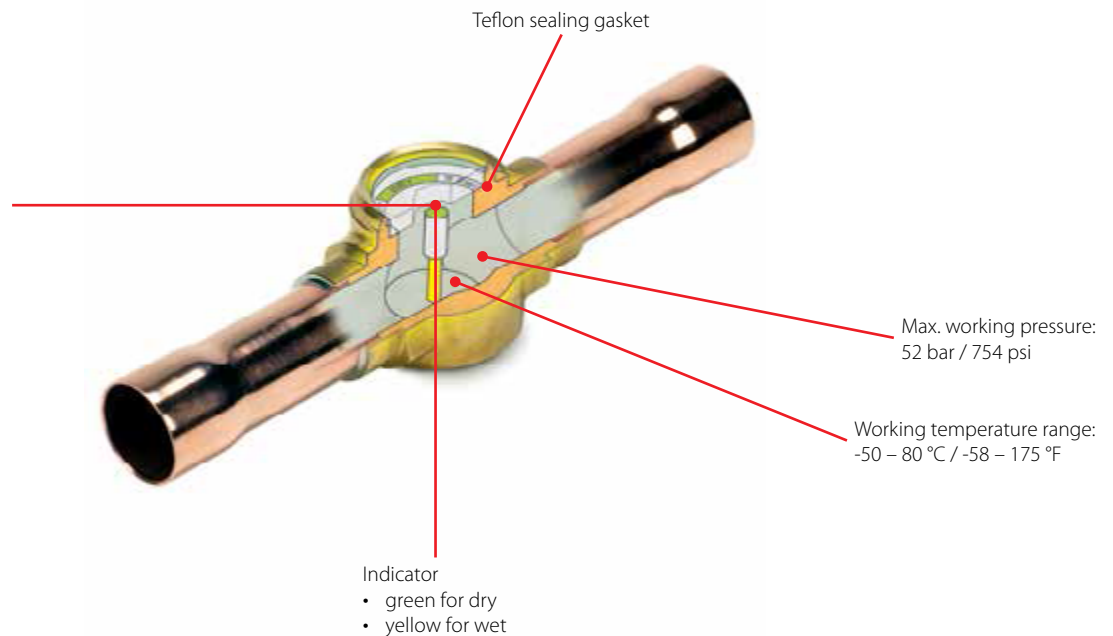

Facts

Applications:

- Traditional refrigeration
- Heat pump systems
- Air conditioning units
- Liquid coolers
- Transport refrigeration

Refrigerants:

- R1270
- R134a
- R22
- R32
- R404A
- R407A
- R407C
- R407F
- R410A
- R448A
- R449A
- R450A
- R452A
- R452B
- R454B
- R513A
- R744
- R1233zd(E)
- R1234ze(E)
- R407H
- R454C
- R455A
- R515B
- R463A
- R1234yf
- R507A

Benefits:

- Indicates too high moisture content in the refrigeration system
- Indicates lack of subcooling
- Indicates refrigerant deficiency

Connection:

- Solder ODF x ODF
- Solder ODF x ODM
- Flare ext. x ext.
- Flare int. x ext.

Connection size:

- From 6 to 22 mm or ¼ to ¾ in.

Technical data and ordering

SGP N

Sight glass (high pressure)



Type	Connection type	Connection (in.)	Connection (mm)	Code no.
SGP 6 N	Flare ext. x ext.	1/4 x 1/4	6 x 6	014L0161
SGP 10 N	Flare ext. x ext.	3/8 x 3/8	10 x 10	014L0162
SGP 12 N	Flare ext. x ext.	1/2 x 1/2	12 x 12	014L0163
SGP 16 N	Flare ext. x ext.	5/8 x 5/8	16 x 16	014L0165
SGP 19 N	Flare ext. x ext.	3/4 x 3/4	19 x 19	014L0166
SGP 6 N	Flare int. x ext.	1/4 x 1/4	6 x 6	014L0171
SGP 10 N	Flare int. x ext.	3/8 x 3/8	10 x 10	014L0172
SGP 12 N	Flare int. x ext.	1/2 x 1/2	12 x 12	014L0173
SGP 16 N	Flare int. x ext.	5/8 x 5/8	16 x 16	014L0174
SGP 19 N	Flare int. x ext.	3/4 x 3/4	19 x 19	014L0175
SGP 6s N	ODF x ODF solder	1/4 x 1/4	–	014L0181
SGP 10s N	ODF x ODF solder	3/8 x 3/8	–	014L0182
SGP 12s N	ODF x ODF solder	1/2 x 1/2	–	014L0183
SGP 16s N	ODF x ODF solder	5/8 x 5/8	16 x 16	014L0184
SGP 19s N	ODF x ODF solder	3/4 x 3/4	19 x 19	014L0185
SGP 22s N	ODF x ODF solder	7/8 x 7/8	22 x 22	014L0186
SGP 22s N	ODF x ODF solder	1 1/8 x 1 1/8	–	014L0187
SGP 6s N	ODF x ODM solder	1/4 x 1/4	–	014L0201
SGP 10s N	ODF x ODM solder	3/8 x 3/8	–	014L0202
SGP 16s N	ODF x ODM solder	5/8 x 5/8	16 x 16	014L0204
SGP 22s N	ODF x ODM solder	7/8 x 7/8	22 x 22	014L0206



Note

Only solder versions are allowed for flammable refrigerants.

GBC version 2, Shut-off ball valve

GBC v2 shut-off ball valves are manually operated valves suitable for bi-directed flow.

Shut-off ball valves are used in liquid, suction and hot gas lines in refrigeration, freezing and air conditioning systems.

The GBC v2 bi-directed shut-off ball valves can be delivered with or without external access port.

The valves have one-piece wire seal cap to prevent unintentional cap removal or tampering between services.

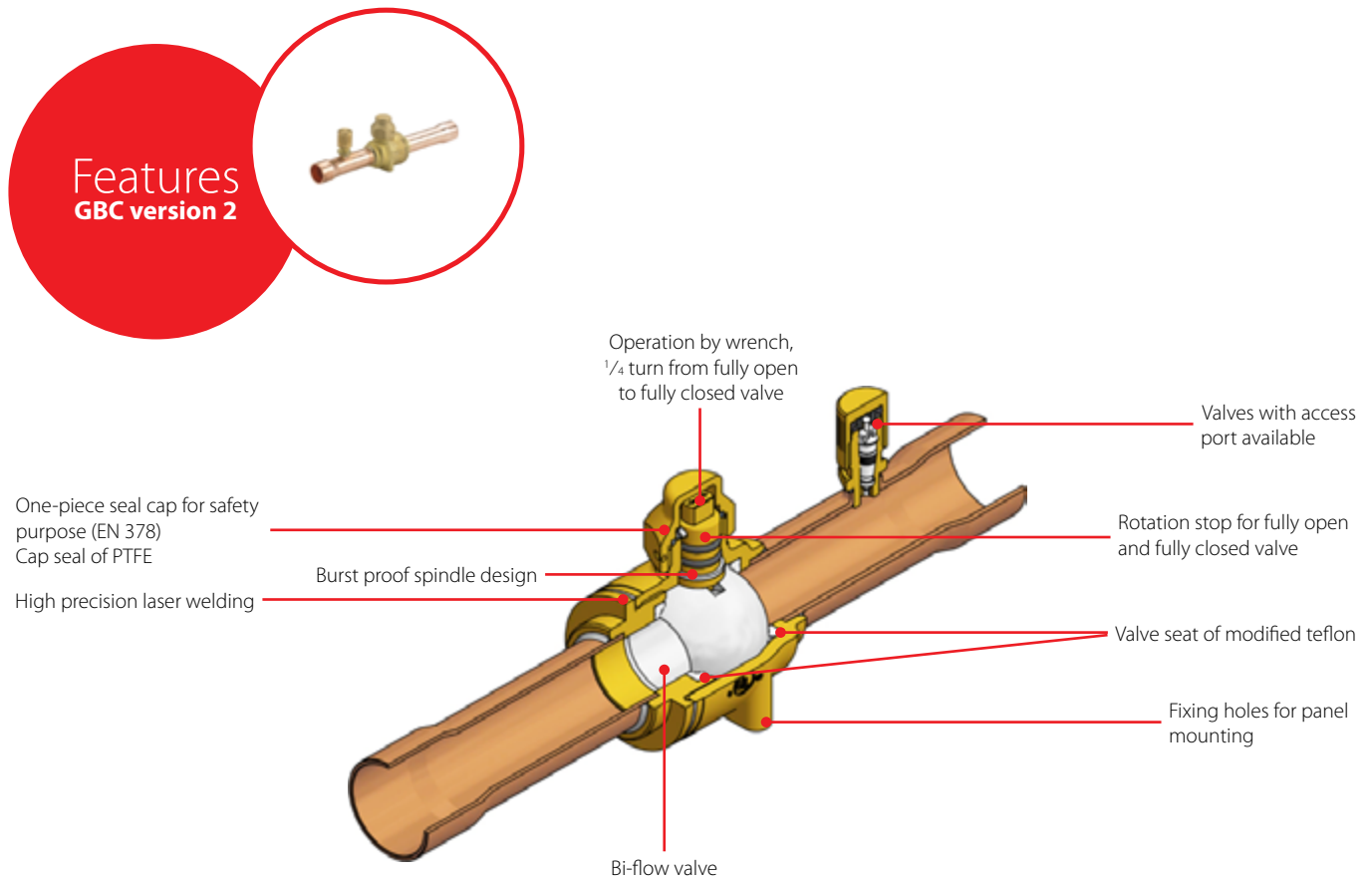

Facts

Applications:

- Liquid, suction and hot gas lines in all refrigeration and air-conditioning systems with fluorinated refrigerants

Refrigerants:

- R134a
- R22/R407C
- R404A/R507
- R407A
- R407F
- R410A
- R448A
- R449A
- R450A
- R452A
- R513A
- R1234yf
- R407H
- R449B
- R454C
- R455A
- R515B
- R516A
- R1234ze(E)
- R290
- R452B
- R454B
- R454A

Benefits:

- Full flow with minimum pressure drop
- Bi-directional flow
- 1/4 turn from fully open to fully closed
- Burst proof spindle design
- Selected Teflon and O-ring material to secure the best tightness and long lifetime
- Versions with access port helps in reducing cost if service of the system is necessary
- One-piece seal cap for safety purpose Complies with European Safety Directive EN 378
- Ball status indicator on spindle top indicating open or closed position
- Laser welded construction
- Drilled and tapped for panel mounting
- Double O-ring stem seal design
- Customized brass material ensures consistent performance under aggressive environment

Technical data and ordering

GBC version 2

Shut-off ball valve

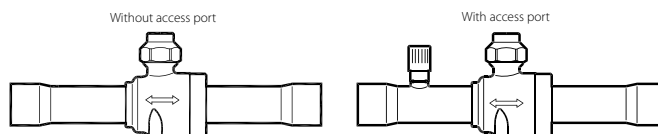

Type	Size		Kv Value (m ³ /h)	Code no.	
	in.	mm		Without Access Port	With Access Port
GBC 6s	1/4	6	1.96	009L7020	009L7050
GBC 10s	3/8	10	5.68	009L7021	009L7051
GBC 12s	1/2	12	10.58	009L7022	009L7052
GBC 16s	5/8	16	14.11	009L7023	009L7053
GBC 18s	3/4	18	20.42	009L7024	009L7054
GBC 22s	7/8	22	28.17	009L7025	009L7055
GBC 28s	1 1/8	28	51.95	009L7026	009L7056
GBC 35s	1 3/8	35	80.89	009L7027	009L7057
GBC 42s	1 5/8	42	121.07	009L7028	009L7058
GBC 54s	2 1/8	54	224.96	009L7029	009L7059
GBC 67s RP	2 5/8	67	310	009L7036	009L7066

01

02

03

04

05

06

07

08

09

10

11

12

13

14

15

Type GBCT, Shut-off ball valve for R744 (CO₂) high pressure

Danfoss shut-off ball valves, type GBCT for R744 (CO₂) high pressure are manually operated shut-off valves for transcritical CO₂ refrigeration systems, in order to open and to shut off inner flow path by operating the valve spindle.

The valve structure and materials are designed and tested specifically for use with CO₂ refrigerant. The valves are approved for use in transcritical CO₂ refrigeration systems.

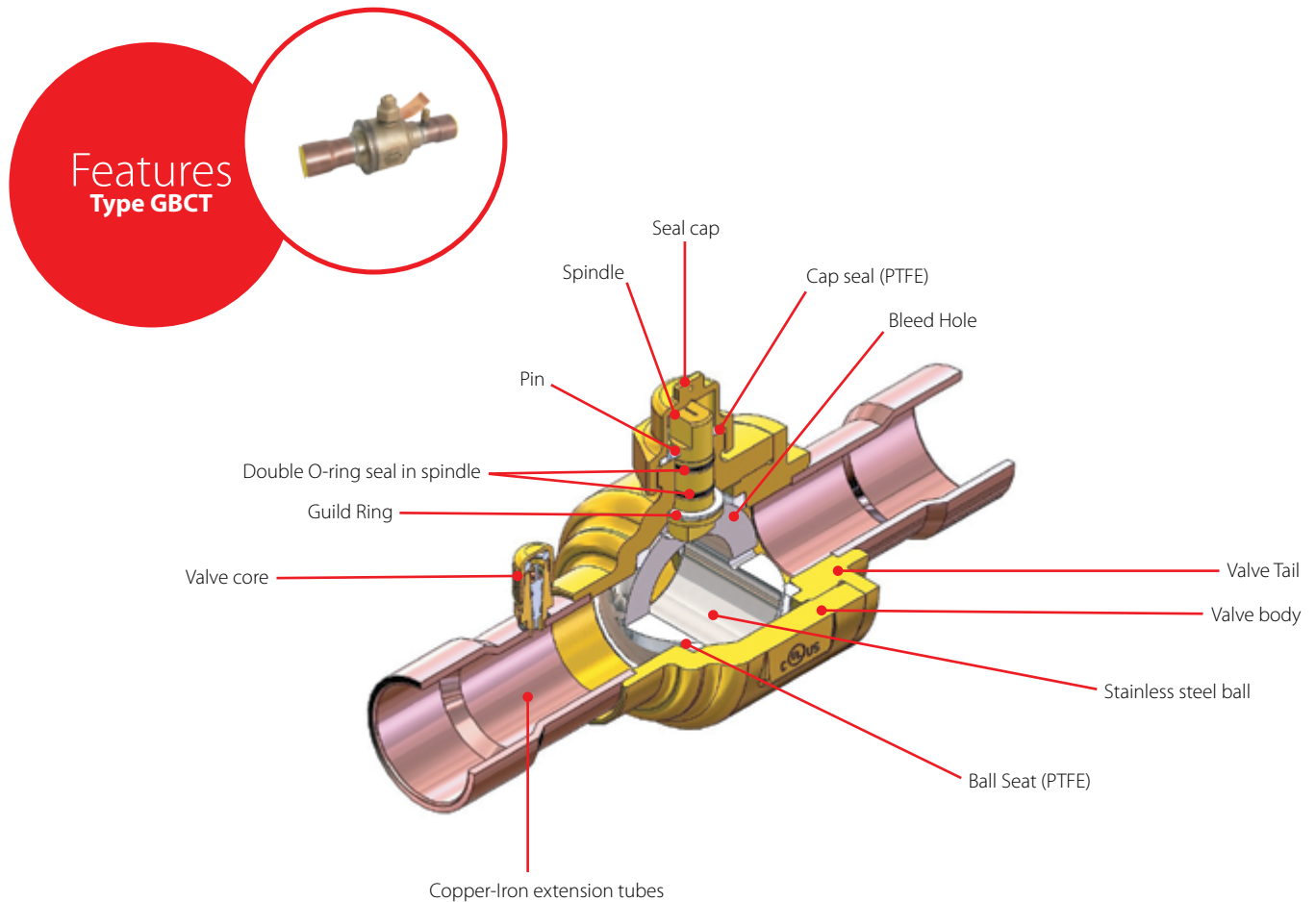

Facts

Features:

- Designed for transcritical CO₂ systems
- Maximum working pressure (PS):
140 bar / 2031 psig
- Temperature range (TS):
-40 °C - 149 °C / -40 °F - 300 °F
- UL/cUL Listed, complies with Pressure Equipment Directive 2014/68/ EU
- Full port construction to match line size
- Rupture proof, internally-loaded spindle design ensures safe operation under extreme pressures
- Specially-selected sealing material for CO₂ refrigerant
- Reinforced copper-iron tube extensions permit trouble-free valve installation with traditional torch-brazing methods
- Bleed hole design avoids liquid entrapment when valve is closed

Technical data and ordering

Type GBCT

Shut-off ball valve for R744 (CO₂) high pressure

Refrigerants	R 744 (CO ₂)
Oils:	POE, PAG
Continuous operating temperature (COT)	-40 °C - 149 °C / -40 °F - 300 °F
Design Pressure (DP) / Maximum abnormal pressure (MAP)	140 bar / 2031 psig
Flow direction	bi-flow

HIGH PRESSURE SIDE "HP" LOW PRESSURE SIDE "LP"



Ordering

GBCT without access port

Type	Size	Kv Value	Multi Pack	Code no.
	(inch)	(m ³ /h)	(Pcs. Per pack)	
GBCT 6s	1/4	0.9	30	009L6415
GBCT 10s	3/8	3.7	30	009L6416
GBCT 12s	1/2	5.4	30	009L6417
GBCT 16s	5/8	10.4	30	009L6418
GBCT 18s	3/4	16.4	16	009L6419
GBCT 22s	7/8	23.7	16	009L6420
GBCT 28s	1 1/8	42.3	4	009L6406
GBCT 35s	1 3/8	67.1	4	009L6410
GBCT 42s	1 5/8	83.1	4	009L6411
GBCT 54s	2 1/8	171.3	2	009L6412

Ordering

GBCT with access port

Type	Size	Kv Value	Multi Pack	Code no.
	(inch)	(m ³ /h)	(Pcs. Per pack)	
GBCT 6s	1/4	0.9	30	009L6581
GBCT 10s	3/8	3.7	30	009L6582
GBCT 12s	1/2	5.4	30	009L6585
GBCT 16s	5/8	10.4	30	009L6586
GBCT 18s	3/4	16.4	16	009L6588
GBCT 22s	7/8	23.7	16	009L6589
GBCT 28s	1 1/8	42.3	4	009L6451
GBCT 35s	1 3/8	67.1	4	009L6453
GBCT 42s	1 5/8	83.1	4	009L6454
GBCT 54s	2 1/8	171.3	2	009L6456

BML, Shut-off diaphragm valves

BML are manual shut-off diaphragm valves designed for installation in the liquid, suction and hot gas lines of refrigeration plants. BML valves can be delivered with flare, ODF solder or ODF solder with extended ends.

In the same product category, BMT 6 is a three-way manual shut-off valve with similar characteristics. BML valve can be used for HCFC, HFC and HC refrigerants.

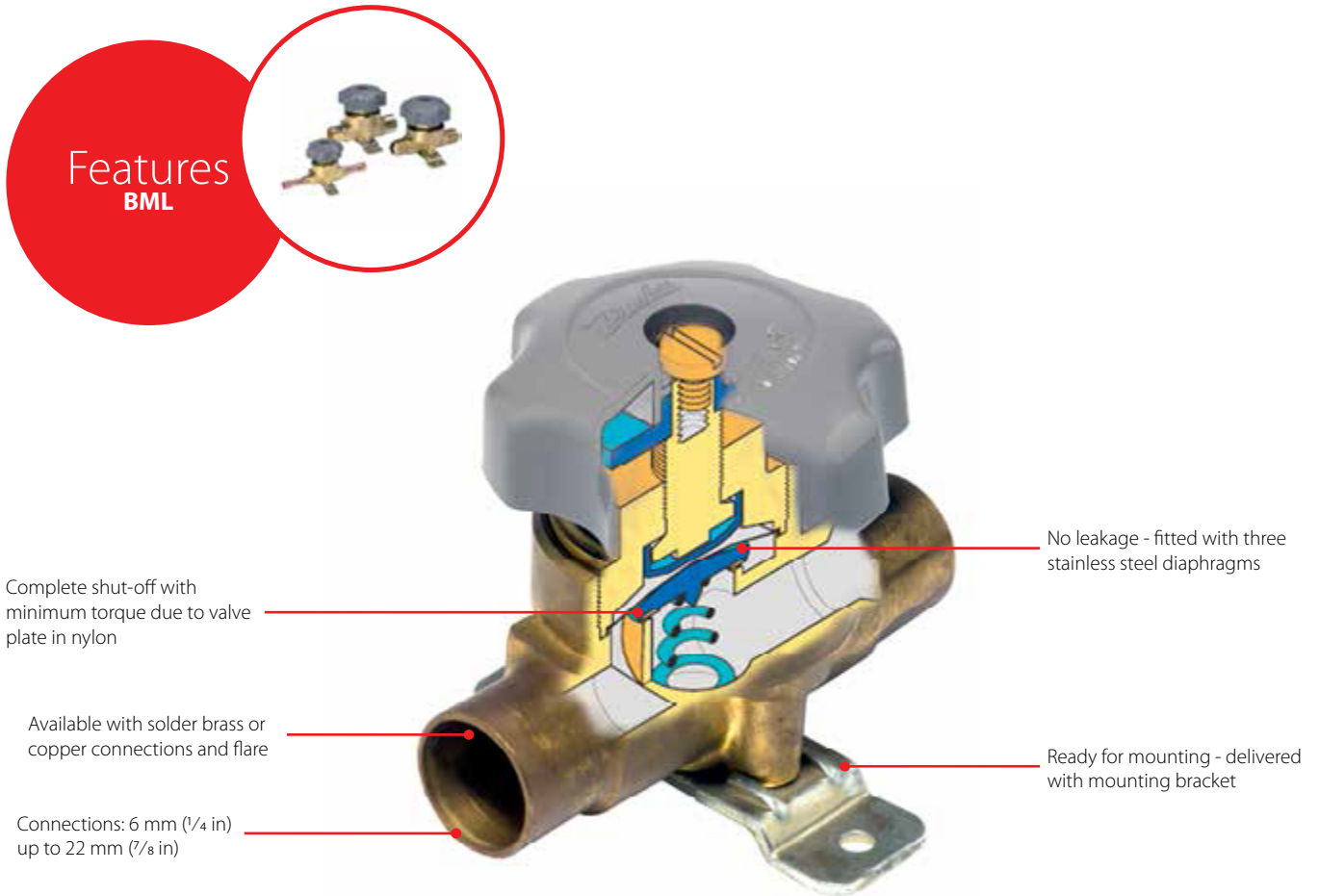

Facts

Applications:

- Traditional refrigeration

Temperature range:

- -55 – 100 °C / -67 – 212 °F

Maximum working pressure:

- 28 bar / 406 psig

Working range:

- -1 – 21 bar / -14 – 304 psig

Refrigerants:

- R1234yf
- R1234ze
- R1270
- R134a
- R22/R407C
- R290
- R404A/R507
- R450A
- R513A
- R600
- R600a
- R407H
- R449B
- R515B
- R516A

Benefits:

- Fitted with three stainless steel diaphragms which ensure long operating life
- Valve plate of polyamide nylon to give complete shut-off with minimum torque
- Valve cover with counter-seat to prevent the ingress of moisture in fully open position

Technical data and ordering

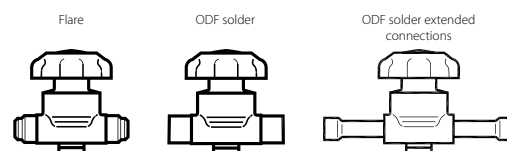

BML

Shut-off diaphragm valves, with hand wheel

Type	Connection (in.)	kv-value (m ³ /h)	Code no.		
			Flare	ODF solder	ODF extended ends
BML 6	1/4	0.3	009G0101	-	009G0202
BML 10	3/8	0.84	009G0127	009G0122	009G0222
BML 12	1/2	1.5	009G0141	-	009G0242
BML 15	5/8	2.2	009G0168	-	-

01

02

03

04

05

06

07

08

09

10

11

12

13

14

15

NRV / NRVH, Check valves

NRV and NRVH check valves can be used in liquid, suction and hot gas lines in refrigeration and air conditioning plants with HCFC, HFC and HC flammable refrigerants. Special versions, with a max. working pressure of 90 bar / 1305 psig are available for CO2 applications.

The valves ensure the correct flow direction and prevent back-condensation from a warm part of the system to the cold evaporator. A built-in damping piston makes the valves suitable for installation in lines where pulsation can occur, e. g. in the discharge line from the compressor.



Min. pressure drop
NRV 0.04 – 0.07 bar / 0.58 – 1.01 psig
NRVH 0.3 bar / 4.35 psig

Max. working pressure
PS / MWP 46 bar / 667 psig

Flare and solder version
NRV 6 – 19
NRV 6s – 35s
NRVH 6s – 35s

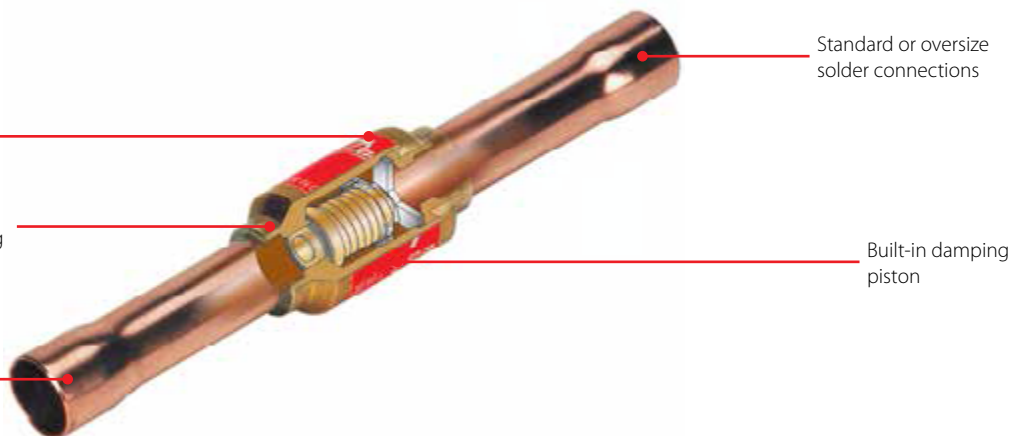

Facts

Applications:

- Traditional refrigeration
- Heat pump systems
- Air conditioning units
- Liquid coolers
- Transport refrigeration

Refrigerants:

- R1233zd(E)
- R1234yf
- R1234ze(E)
- R1270
- R134a
- R22/R407C
- R290
- R32
- R404A/R507
- R407A
- R407F
- R407H
- R410A
- R448A
- R449A
- R449B
- R450A
- R452A
- R452B
- R454B
- R454C
- R455A
- R513A
- R515B
- R516A
- R600
- R600a
- R454A

Benefits:

- Hermetic tight design for solder versions
- Built-in damping piston that makes the valves suitable for installation in lines where pulsation can occur, e.g. in the discharge line from the compressor
- Available in both straightway and angleway versions
- Solder versions are compliant with ATEX hazard zone 2
- NRVH type check valve is with stronger spring and it's recommended to use for compressors in parallel (i.e. power packs) where higher level of pulsation and vibration are expected

Technical data and ordering

NRV / NR VH - Check valves

Technical data

Type	Description
Temperature range	-50 - 140 °C / -58 - 285 °F
Max. working pressure (PS/ MWP)	46 bar / 667 psig
Approvals	C UL US LISTED, EAC

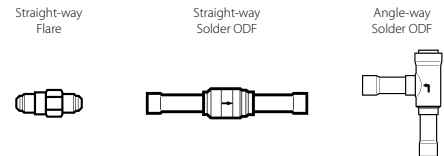

NRV / NR VH

Check valves

Type	Version		Connection		Pressure drop across valve Δp bar ¹⁾	kv-value ²⁾ m ³ /h
			Size			
			in.	Code no.		
NRV6	Straight - way	Flare	1/4	020-1040	0.07	0.56
NRV 10	Straight - way	Flare	3/8	020-1041	0.07	1.43
NRV 12	Straight - way	Flare	1/2	020-1042	0.05	2.05
NRV 16	Straight - way	Flare	5/8	020-1043	0.05	3.6
NRV 6s	Straight - way	Solder ODF	1/4	020B1010	0.07	0.56
NRV 6s ³⁾	Straight - way	Solder ODF	3/8	020B1057	0.07	0.56
NRVH 6s ³⁾	Straight - way	Solder ODF	3/8	020B1069	0.3	0.56
NRV 10s	Straight - way	Solder ODF	3/8	020B1011	0.07	1.43
NRV 12s	Straight - way	Solder ODF	1/2	020B1012	0.05	2.05
NRV 12s ³⁾	Straight - way	Solder ODF	5/8	020B1052	0.05	2.05
NRV 16s	Straight - way	Solder ODF	5/8	020B1018	0.05	3.6
NRVH 16s	Straight - way	Solder ODF	5/8	020B1038	0.3	3.6
NRVH 16s ³⁾	Straight - way	Solder ODF	3/4	020B1071	0.3	3.6
NRV 19s	Straight - way	Solder ODF	3/4	020B1019	0.05	5.5
NRVH 19s	Straight - way	Solder ODF	3/4	020B1023	0.3	5.5
NRVH 19s ³⁾	Straight - way	Solder ODF	7/8	020B1066	0.3	5.5
NRV 19s ³⁾	Straight - way	Solder ODF	7/8	020B1054	0.05	5.5
NRV 22s	Angle - way	Solder ODF	7/8	020-1020	0.04	8.5
NRVH 22s	Angle - way	Solder ODF	7/8	020-1032	0.03	8.5
NRV 22s ³⁾	Angle - way	Solder ODF	1 1/8	020-1060	0.04	8.5
NRVH 22s ³⁾	Angle - way	Solder ODF	1 1/8	020-1072	0.3	8.5
NRV 28s	Angle - way	Solder ODF	1 1/8	020-1021	0.04	19
NRV 28s ³⁾	Angle - way	Solder ODF	1 3/8	020-1056	0.04	19
NRV 35s	Angle - way	Solder ODF	1 3/8	020-1026	0.04	29
NRVH 35s	Angle - way	Solder ODF	1 3/8	020-1034	0.3	29
NRV 35s ³⁾	Angle - way	Solder ODF	1 5/8	020-1061	0.04	29

1) Δp = the minimum pressure at which the valve is completely open.

The NR VH with a stronger spring is used in the discharge line from compressors connected in parallel.

2) The Kv value is the flow of water in m³/h at a pressure drop across valve of 1 bar, $\rho = 1000 \text{ kg/m}^3$.

3) Oversize connections.

Max operating pressure is 90 bar.

Technical data and ordering

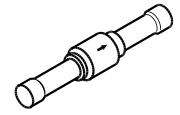

NRV 10s H - Check valve for R744 (CO₂)

Technical data

Type	Description
Refrigerants	R744 (CO ₂)
Oil	POE, PAG
Temperature range	-50 - 140 °C / -58 - 285 °F
Max. working pressure (PS / MWP)	90 bar / 1305 psig
Approvals	C UL US LISTED, EAC

NRV 10s H - Check valve, straight-way - solder ODF

Ordering

Type	Connection type	Connection size		Differential pressure to start opening the valve		Pressure drop across valve Δp		Kv - value ²⁾	Cv - value ²⁾	Code no.
		[in]	[mm]	[bar] ¹⁾	[psi] ¹⁾	[bar] ¹⁾	[psi] ¹⁾	[m ³ /h]	[gal/min]	
NRV 10s H	Straightway Solder ODF	3/8	-	0.4	5.8	1.0	14.5	0.9	1.04	020-4000

1) Δp_1 = the minimum pressure at which the valve start opening.

Δp_2 = the minimum pressure at which the valve is completely open.

2) The Kv / Cv value is the flow of water in [m³/h] / [gal/min] at a pressure drop across valve of 1 bar / 14.5 psig, $\rho = 1000 \text{ kg/m}^3 / 2205 \text{ lbs/G}$.

ERC 211 / ERC 213 / ERC 214, Refrigeration controllers

ERC 21X is a smart multipurpose refrigeration controller with temperature and defrost management.

The controller has been designed to fulfill today's requirements of advanced commercial Refrigeration applications.

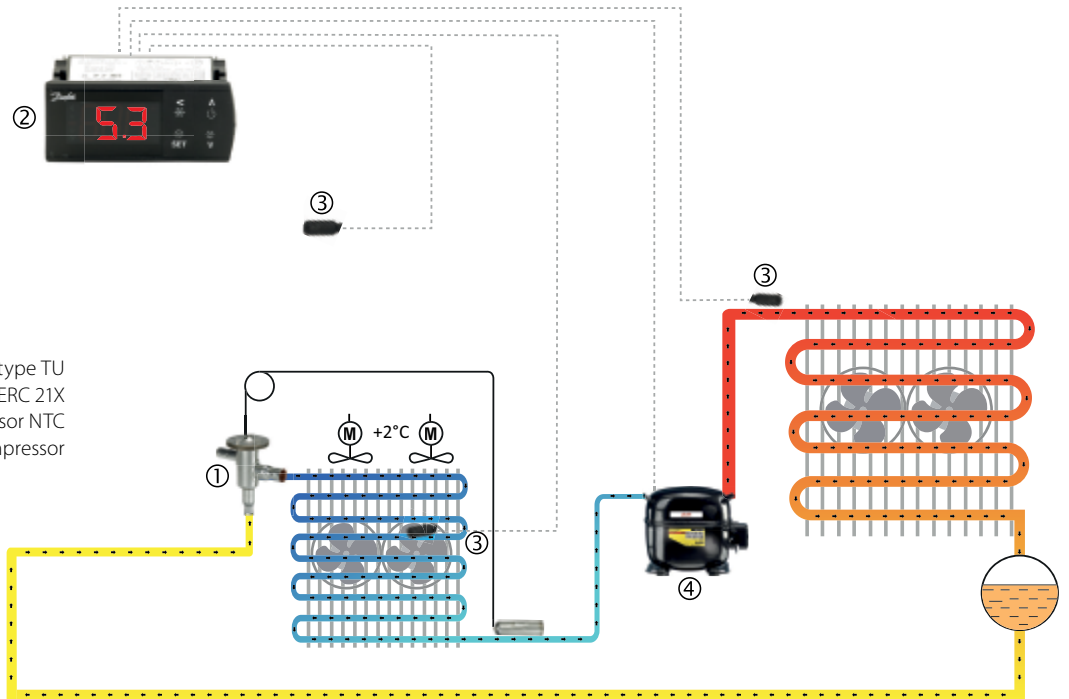

- 1. Thermostatic expansion valve type TU
- 2. Temperature controller ERC 21X
- 3. Temperature sensor NTC
- 4. Compressor

Facts

Thermostat:

- ON / OFF thermostat
- Day / Night, continuous cycle, emergency mode
- Pre-installed applications
- Compatible with wide range of sensors (NTC 5 K and 10 K, Pt1000, PTC)

Defrost:

- Natural, electrical and hot gas defrost
- Defrost on demand
- Start via push button, DI input or time interval
- Stop on time, temperature or push button

Compressor:

- Voltage protection
- Anti-cycle timers for optimum compressor protection
- High-effect 16 A relays for connection of compressors

Evaporator Fan:

- Fan delay function
- Smart evaporator fan management for energy saving
- Fan stop at high evaporator temperature

Alarms:

- High and low temperature alarm
- Sensor failure alarm
- High and low voltage alarm
- Condenser cleaning alarm
- Door open alarm
- External alarm input

Multi-purpose DI input:

- Two multipurpose DI input for defrost start, Day / night control, main switch, reference displacement and continuous cycle control

Display & programming:

- Bigger and High efficient LED Display
- Display temperatures in °C / °F
- Parameter settings/readouts and alarm conditions can be read on the display

Other functions:

- Zero cross switching in all relays
- Three levels password protection
- Door function with alarm monitoring
- Delay of outputs at power up
- Keypad lock and unlock feature
- Galvanic Isolation

Technical data and ordering

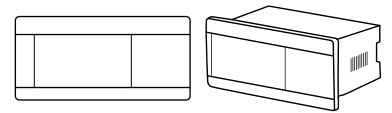

ERC 211 / ERC 213 / ERC 214

Refrigeration controllers

Type	Description	Code no.
ERC211	KIT - ERC 211,RED LED,230V. Supplied with 1 NTC10K Temp. Probe 1.5m	080G3263
ERC213	KIT - ERC 213,RED LED,230V. Supplied with 2 NTC10K Temp. Probe 1.5m	080G3265
ERC214	ERC 214,Controller, RED LED, 230V. Temp Probe ordered separately	080G3295

Spares:

Elastomer Cap - 080G4025

NTC 10K probe 3m - 084N3210

01

02

03

04

05

06

07

08

09

10

11

12

13

14

15

LP-ETS kit and ETS, Superheat controller

Superheat control in Cold stores, processing plants or A/C plants with Stepper Valve

Features LP-ETS kit & ETS

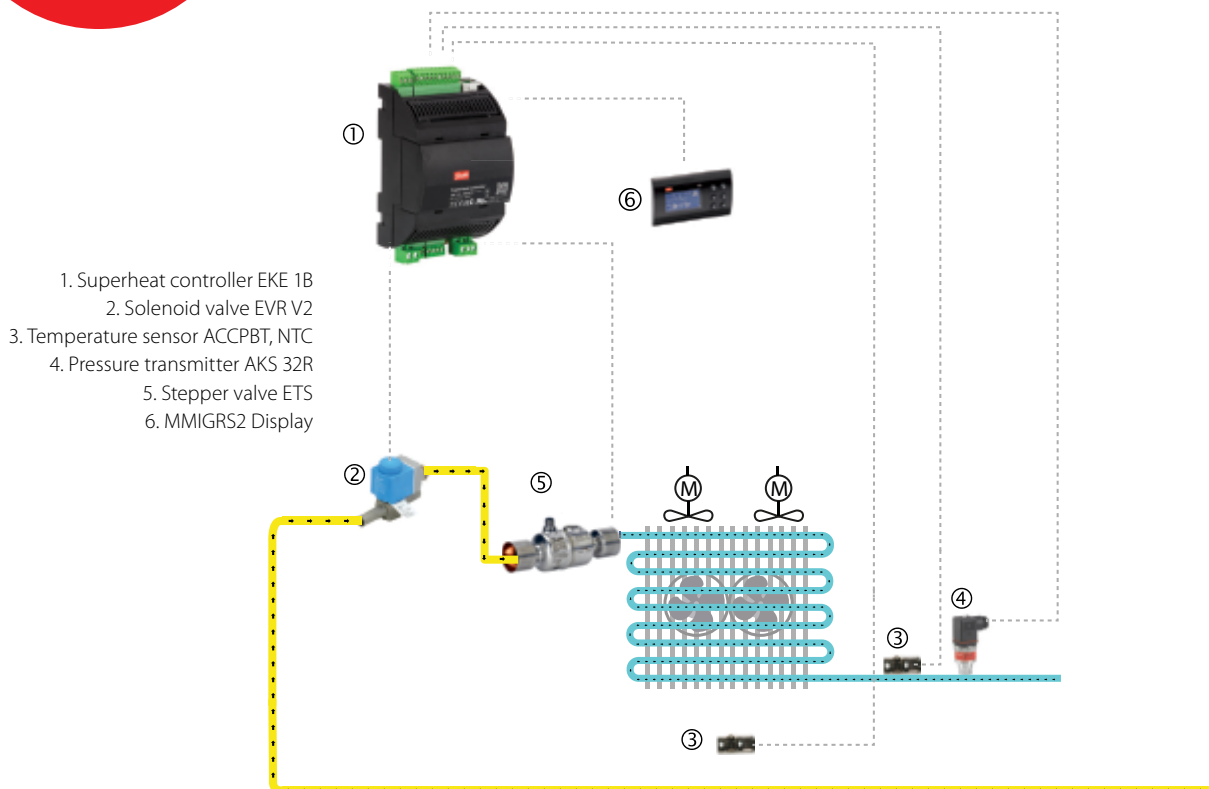

Facts

Benefits:

- The evaporator is charged optimally even when there are great variations of load and suction pressure
- Energy savings
- The superheating is regulated to the lowest possible value at the same time as the media temperature is controlled by the thermostat function

Functions:

- Regulation of superheat
- Temperature control
- MOP function
- ON/OFF input for start/stop of regulation
- Input signal that can displace the superheat reference or the temperature reference
- Alarm if the set alarm limits are exceeded
- Relay output for solenoid valve
- PID regulation

Energy Saving:

- The adaptive regulation of the refrigerant injection ensures optimum utilization of the evaporator and hence a high suction pressure

Technical data and ordering

Ordering Code: LP-ETS-KIT

Kit Includes the following codes

Description	Code no.	PSC
Superheat Controller, EKE 1B	080G5350	1
Pressure transmitter, AKS 32R (1/4" flare -1- 34 bar)	060G0090	1
ACCPBT, NTC Temperature probe, IP68 6X20, 3m Cable	080G0202	2
Din Plug	060G0008	1
120 Ohm Resistors	LP-RR0550	2
Control Panel (MMGIRS2)	080G0294	1
ACCCBI Cable, Telephone U.I. 1.5m	080G0075	1

Note:

-Please note, that the 240/24V transformer and stepper valve are not included in the kit.

Accessory, Power Supply- AK-PS 075- 080Z0053

Backup power module, EKE 2U- 080G5555

AK-CC 250A, Universal refrigeration controller

The controller is used for evaporator control refrigeration appliances in supermarkets. With many predefined applications one unit will

offer you many options. Flexibility has been planned both for new installations and for service in the refrigeration trade.

Features AK-CC 250A

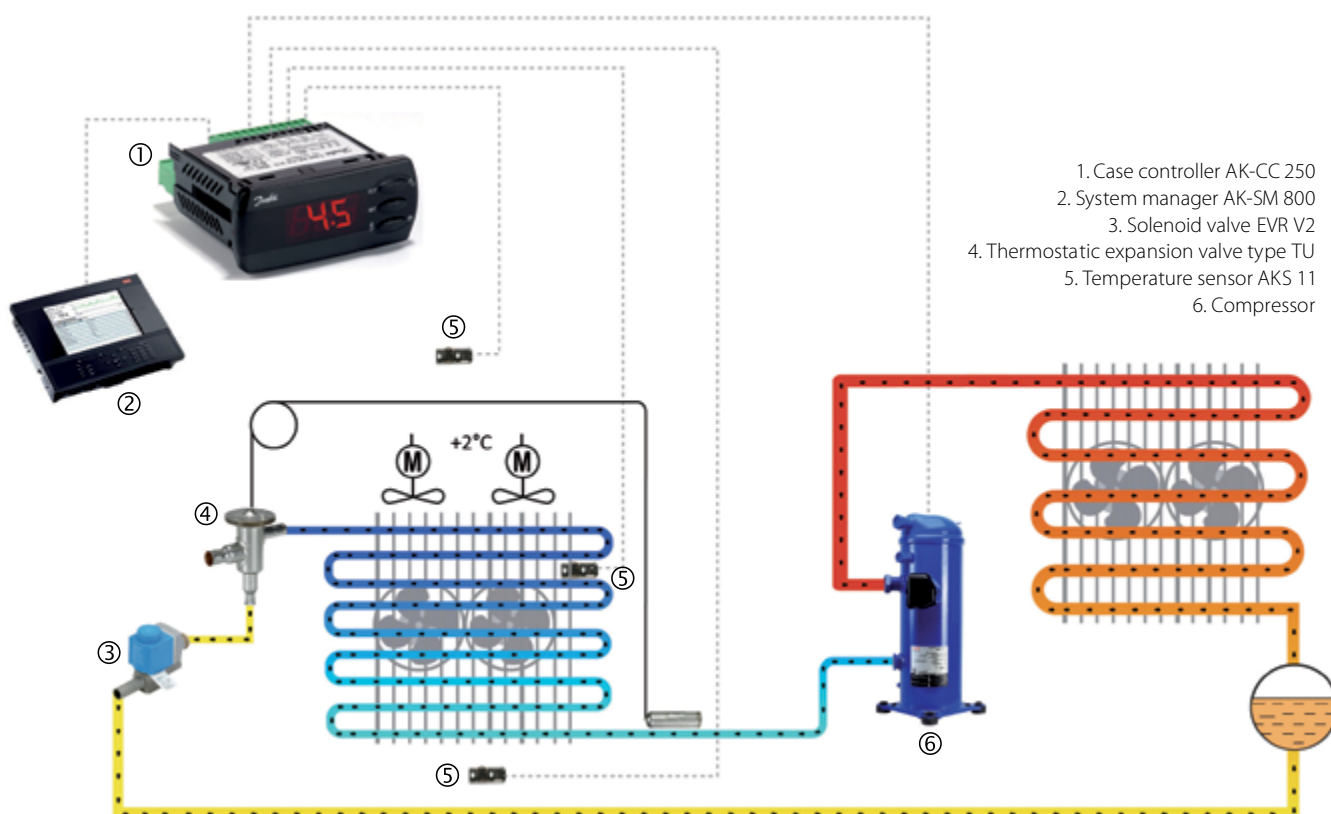

1. Case controller AK-CC 250
2. System manager AK-SM 800
3. Solenoid valve EVR V2
4. Thermostatic expansion valve type TU
5. Temperature sensor AKS 11
6. Compressor

Facts

Benefits:

- Many applications in the same unit
- The controller has integrated refrigeration-technical functions, so that it can replace a whole collection of thermostats and timers
- Buttons and seal imbedded in the front
- Can control two compressors
- Fixed MODBUS data communication
- Easy to remount data communication
- Quick setup
- Two temperature references
- HACCP (Hazard Analysis and Critical Control Points):
 - temperature monitoring and registration of period with too high temperature
 - factory calibration that will guarantee a better measuring accuracy than stated in the standard EN 441-13 without subsequent calibration (Pt 1000 ohm sensor)
- Digital inputs for various functions
- Clock function with backup

Technical data and ordering

AK-CC 250A

Universal refrigeration controller

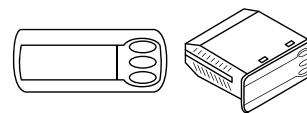

Features	Description		
Supply voltage	230 V AC 10 – 15% 2.5 V A		
Sensors for AK-CC 250A, 3 pcs off either	Pt 1000 ohm (0 °C) PTC (1000 ohm / 25 °C) NTC-M2020 (5000 ohm / 25 °C) Measuring range: -60 – 99 °C		
Accuracy	Controller: ± 1 K below -35 °C, ± 0.5 K between -35 – 25 °C, ± 1 K above +25 °C Pt 1000 sensor: ± 0.3 K at 0 °C, ± 0.005 K per grad		
External display	EKA 163 A (only in stand alone)		
Digital inputs	Signal from contact functions Requirements to contacts: Gold plating Cable length must be max. 15 m Use auxiliary relays when the cable is longer		
Electrical connection cable	Max. 1.5 mm ² multi-core cable		
Relays *)	CE (250 V AC)		UL *** (240 V AC)
	DO1. Refrigeration	8 (6) A	10 A Resistive 5 FLA, 30 LRA
	DO2. Defrost	8 (6) A	10 A Resistive 5 FLA, 30 LRA
	DO3. Fan	6 (3) A	6 A Resistive 3 FLA, 18 LRA - 131 VA Pilot duty
	DO4. Alarm	4 (1) A Min. 100 mA **)	4 A Resistive 131 VA Pilot duty
Environments	0 – 55 °C, During operations		
	-40 – 70 °C, During transport		
	20 – 80% Rh, not condensed		
Enclosure	No shock influence / vibrations		
Escapement reserve for the clock	IP65 from front Buttons and packing are embedded in the front		
Escapement reserve for the clock	4 hours		
Approvals	EU Low Voltage Directive and EMC demands re CE-marking complied with LVD tested acc. EN 60730-1 og EN 60730-2-9, A1, A2 EMC tested acc. EN50082-1 og EN 60730-2-9, A2		

*) DO1 and DO2 are 16 A relays. DO3 and DO4 are 8 A relays. Max. load must be kept
 **) Gold plating ensures make function with small contact loads
 ***) UL-approval based on 30000 couplings

Ordering

Description	Code no.	PSC
Case Controller, AK-CC 250	084B8528	1
Sensor AKS 12 1.5m PT1000	084N0036	2
Thermostatic Expansion Valve, TU	Refer to data sheet for selection	1
Solenoid Valve, EVR	Refer to data sheet for selection	1
Scroll Compressor	Refer to data sheet for selection	1
EKA 183A Programming Key	084B8582	1

AK-CC 55 Room/ Case controller (Pulse valve)

AK-CC 55 is a complete refrigeration appliance control with great flexibility to adapt to all types of refrigeration appliances and cold storage rooms.

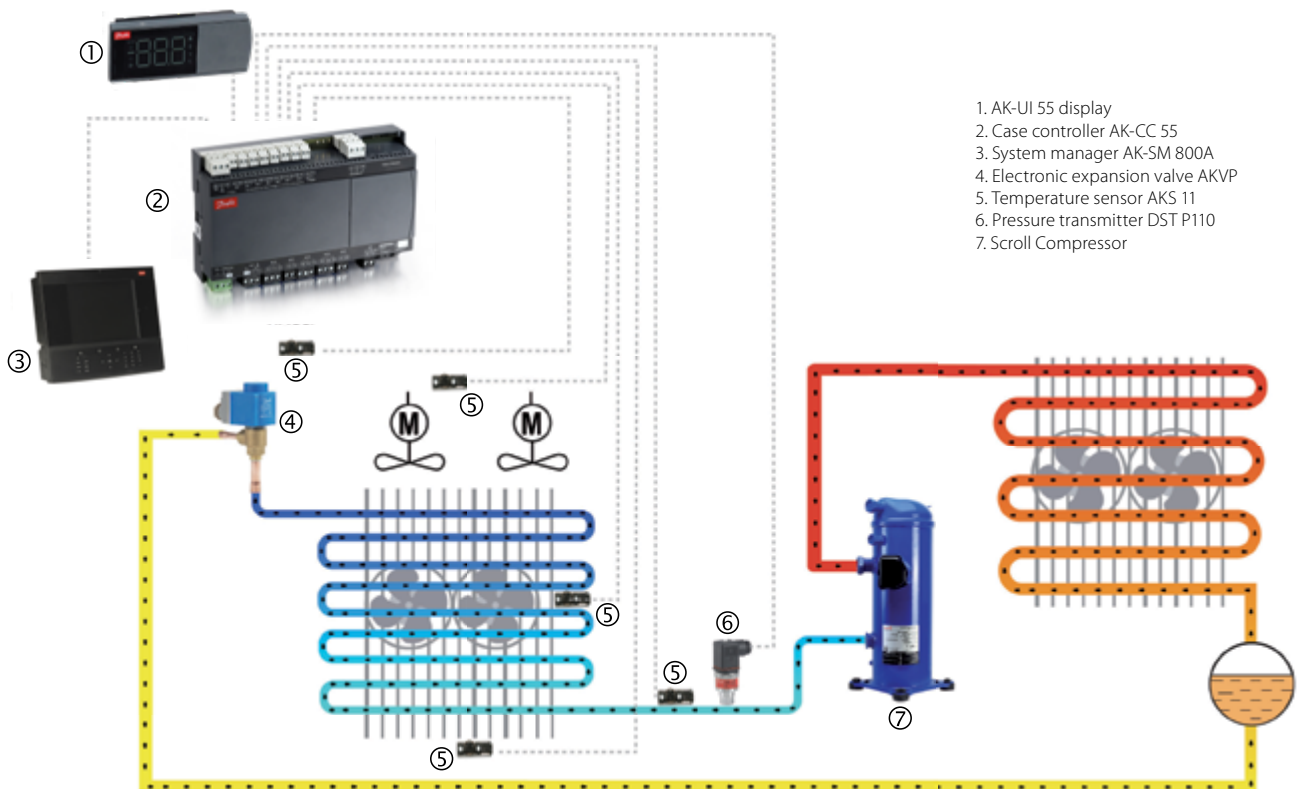

1. AK-UI 55 display
2. Case controller AK-CC 55
3. System manager AK-SM 800A
4. Electronic expansion valve AKVP
5. Temperature sensor AKS 11
6. Pressure transmitter DST P110
7. Scroll Compressor

* Pulsing valve may cause damage to weak joints in 1-1 system.

Facts

Benefits:

- Allows the suction pressure to be raised several degrees
- Energy optimization of the whole refrigeration appliance
- Adaptive Minimum Stable Superheat (MSS) control is performed with lowest possible superheat
- Adaptive Liquid Control (ALC) can be performed with superheat down to 0 degrees on transcritical CO₂ systems with liquid ejectors (ALC is available in selective AK-CC 55 models)
- One controller for several different refrigeration appliances
- Quick set-up with predefined settings
- Easy configuration and service using a mobile app with Bluetooth

Technical data and ordering

AK-CC 55

Controller for appliance control

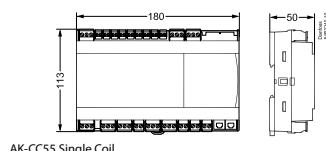

Features	Description	
Supply voltage	115 / 230 V AC (85-265V). 5 V A, 50 / 60 Hz Power: Green LED	
Sensor S2, S6	Pt 1000	
Sensor S3, S4, S5	Pt 1000 or PTC 1000 or Ntc 5K or Ntc 10K (All 3 must be of the same type)	
Measuring of temperature	PT 1000: -60 – 120 °C, ± 0.5 K PT 1000: -60 – 80 °C, ± 0.5 K NTC 5K: -40 – 80 °C, ± 1.0 K NTC 10K: -40 – 120 °C, ± 1.0 K	
	Pt 1000 sensor	± 0.3K at 0 °C ± 0.005 K per degree
Measuring of Pe	Ratiometric pressure transmitter	10-90%
Measuring of RH	0-10 V	Ri > 10K ohm Accuracy +/- 0.3% FS
Display	LED, 3-digits	
External display	1 pc RJ12 output on compact versions and versions with integrated displays 2 pcs, RJ12 outputs on versions without displays Max. 100m cable total	
Digital inputs DI1, D2	Signal from contact functions Requirements to contacts: Gold plating Cable length must be max. 15 m Use auxiliary relays when the cable is longer Open loop: 12 V Contact 3.5 mA	
Digital inputs DI3	115 V / 230 V AC	
Electrical cable dimensions	Max. 1.5 mm ² multi-core cable	
Solid state output	DO1 (for AKV coil) (DO3 and DO7 in Multi Coil)	115 V / 230 V AC Max. 0.5 A Max. 1 x 20 W AKV for 115 V AC 2 x 20 W AKV for 230 V AC
Relays *	DO2, DO3, DO4 DO5, DO6	115 V / 230 V AC Load max.: CE. 8 (6)A UL 8A res. 3FLA 18LRA Load min.: 1VA Inrush: DO2 DO3 for Compact DO5 DO6 for Single/Multi Coil TV-5 80A
Analogue output/ PWM	AO1	0 / 10 V Pulse Width Modulated (PWM) max. 15mA. 0-10 V variable, max. 2mA
Environments	0 – 55 °C, During operations -40 – 70 °C, During transport 20 – 80% Rh, not condensed No shock influence / vibrations	
Density	IP20	
Mounting	DIN-rail	
Weight	0.4 Kg	
Data communication	Fixed	MODBUS
Tx: Yellow LED Rx: Green LED	Extension options: (Not for Compact version)	LON RS485
Power reserve for the clock	4 days	
Approvals	EU Low Voltage Directive and EMC demands re CE-marking complied with LVD (2014/35/EU) CB scheme acc. to IEC 60730-1 and 2-9 EMC (2014/35/EU) EN 61000-6-2 and 6-3 Relays tested acc. to IEC 60079-15	

* DO2 to DO6 are 16 A relays. Max. load must be observed. DO3 DO4 for Compact and DO5 DO6 for Single/ Multi Coil is recommended for EC Fan and LED light.
All relays are sealed for use with flammable refrigerant like Propane R290.
Compliance with EN 60 335-2-89: 2010 Annex BB.

Technical data and ordering

Ordering

Description	Code no.	PSC
Controller with Modbus communication (single coil, 230V)	084B4082	1
AK-UI display	084B4076	1
Display cable (RJ12 connector, 3m)	084B4078	1
Temperature probe AKS 11 (3.5 m cable, -50 to 100°C)	084N0003	3
Pressure transmitter, AKS 32R (1/4" flare -1 to 12 bar)	060G1036	1
Pressure transmitter plug (5m cable)	060G1034	1

Note: Other options of controller are available.

AK-PC 351, Capacity controller

AK-PC 351 is used for capacity regulation of compressors and condensers in small refrigeration applications.
A maximum of 4 compressors and one condenser can be regulated:

- One suction group + one condenser group, max. 6 steps
- One compressor group, max. 4 steps
- One condenser group, max. 4 steps

Features AK-PC 351

1. AK-PC 351 Pack controller
2. System manager AK-SM 800
3. VLT® Frequency converter FC 103
4. Pressure transmitter AKS 32R
5. Scroll compressor
6. Temperature Sensor

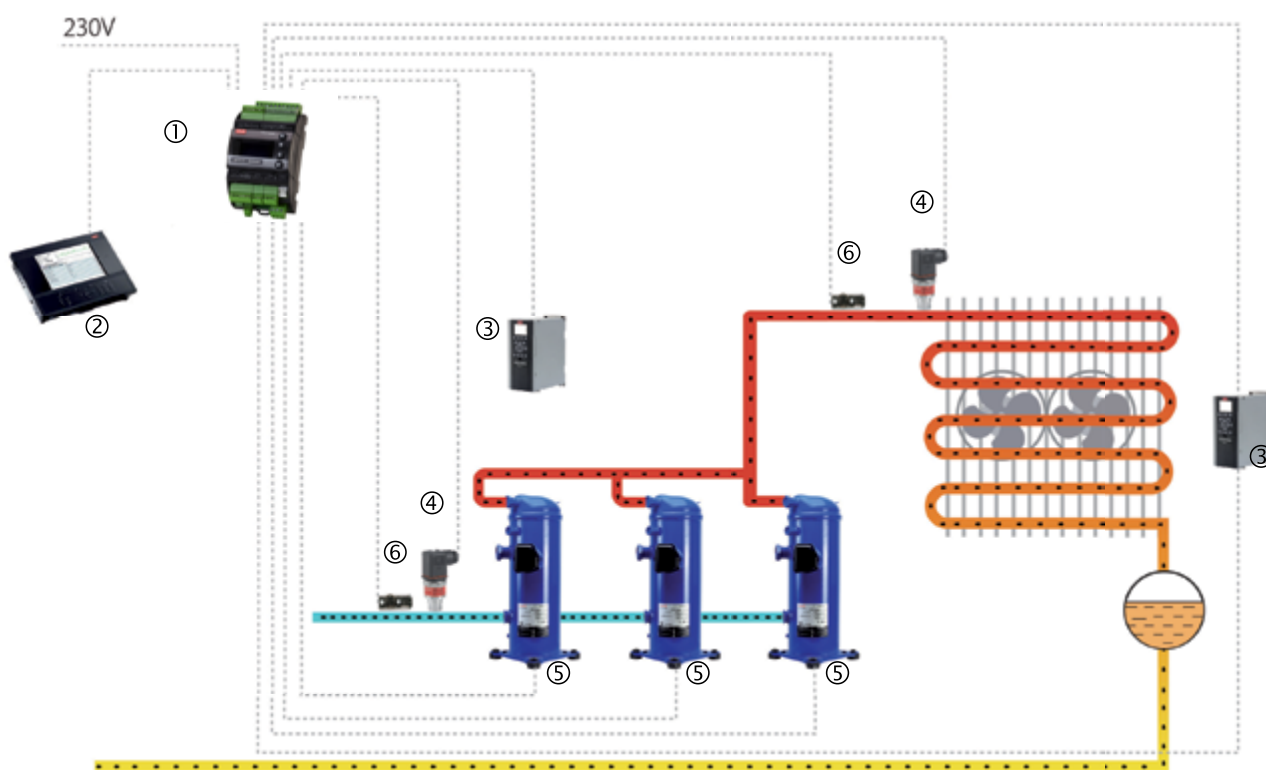

Facts

Benefits:

- Energy savings via:
 - optimisation of suction pressure
 - night time increase
 - floating condensing pressure

Technical data and ordering

AK-PC 351

Capacity controller

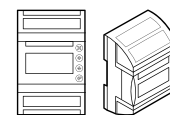

Features	Description
Supply voltage	24 V AC \pm 15%, 50 / 60 Hz, 17 V A 24 V DC (20 – 60 V), 17 V A
4 analog Input	Pressure measuring: Ratiometric pressure transmitter type AKS 32R 1 – 5 volt pressure transmitter type AKS 32 0 – 20 (4 – 20) mA pressure transmitter type AKS 33 Temperature measurement Pt 1000 ohm / 0 °C NTC - 86 K from digital scroll / stream
8 digital input	From contact function E.g. to: Start / stop of regulation Monitoring of safety circuits General alarm function
Relay output to capacity control	5 pcs. SPST (5 A): AC-1: 5 A (ohmic) 5 pcs. SPST (5 A): AC-15: 2 (inductive) 1 pc. Solid State PWM for scroll -unload I _{max.} = 0.5 A I _{min.} = 50 mA Leak < 1.5 mA
2 Voltage output	0-10 V DC Ri = 1 kohm
Data communication	Modbus for AK-SM 850
Environments	-20 – 60 °C, During operations -40 – 70 °C, During transport 20 – 80% Rh, not condensed No shock influence / vibrations
Enclosure	IP40
Weight	0.2 kg
Mounting	DIN-rail
Connection terminals	max. 2.5 mm ² multi core
Approvals	EU Low Voltage Directive and EMC demands re CE-marking complied with LVD tested acc. EN 60730-1 and EN 60730-2-9 EMC-tested acc. EN61000-6-2 and 3

Ordering

Description	Code no.	PSC
Pack Controller AK-PC 351 (24 V)	080G0289	1
Pressure transmitter AKS 32R for suction (1/4" flare -1 to 12 bar)	060G1036	1
Pressure transmitter AKS 32R for discharge (1/4" flare -1 to 34 bar)	060G0090	1
Plug with 5 m cable	060G1034	2
Temperature sensor AKS 11 for suction (3.5 m cable, -50 to 100°C)	084N0003	1
Temperature sensor AKS 21A for discharge (5 m cable, -70 to 180°C)	084N0008	1
Speed drive FC-103 for lead compressor and condenser	consult FC-103 configuration tool(drives.danfoss.com)	
Scroll Compressors, third party compressors		

AK-PC 551, Capacity controller

AK-PC 551 is used for capacity regulation of compressors and condensers in small refrigeration applications. A maximum of 8 compressors and one condenser can be regulated:

- One suction group + one condenser group
- Two suction groups + one shared condenser, max. 4 + 4 steps
- One compressor group, max. 8 steps
- One condenser group, max. 8 steps

Features AK-PC 551

1. Pack controller AK-PC 551
2. Remote graphical display MMIGRS2
3. System Manager AK-SM 800
4. VLT® Frequency converter FC 103
5. Pressure transmitter AKS 32R
6. Temperature sensor AKS 11
7. Scroll compressor

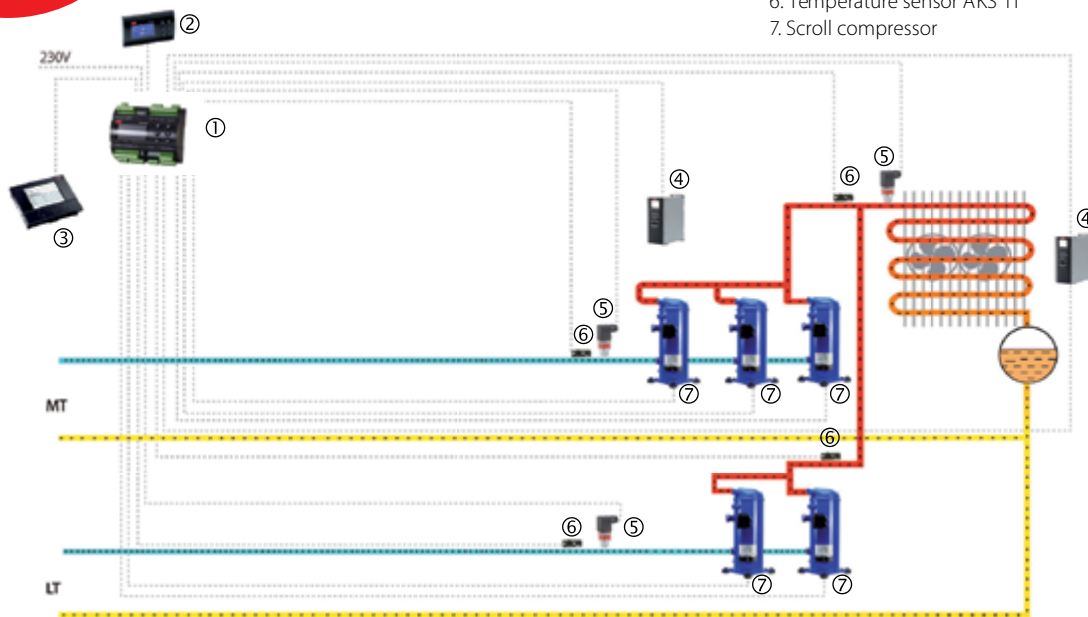

One Suction

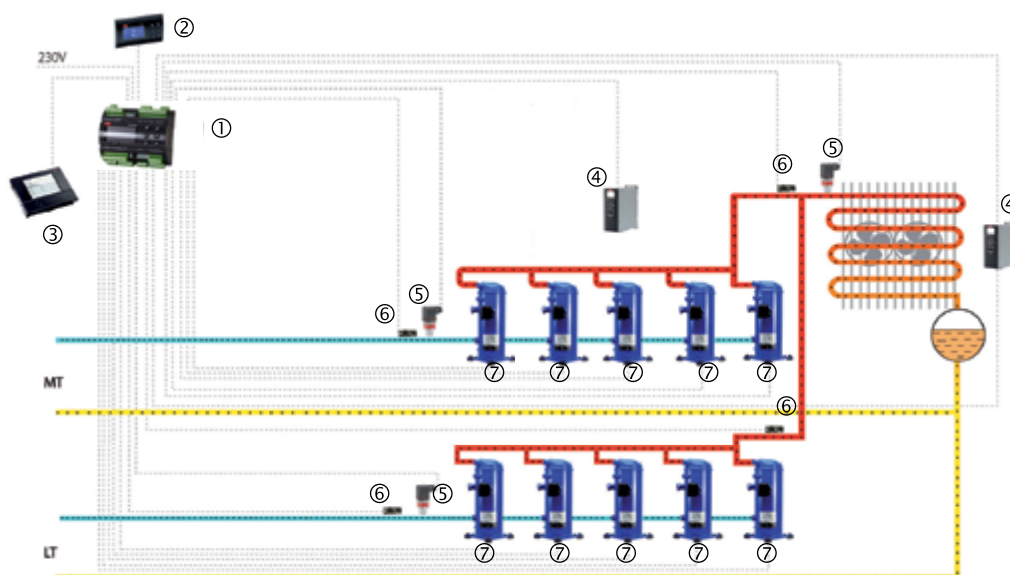

Two Suction

Facts

Benefits:

- Energy savings via:
 - optimisation of suction pressure
 - night time increase
 - floating condensing pressure
 - load limitation

Technical data and ordering

AK-PC 551

Capacity controller

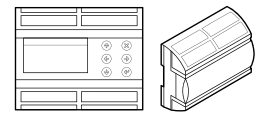

Features	Description			
Supply voltage	24 V AC \pm 15%, 50 / 60 Hz, 17 V A			
	24 V DC (20 – 60 V), 17 V A			
	230 V AC (85 – 265 V) 50 / 60 Hz, 20 V A			
8 analog Input	Pressure measuring: Ratiometric pressure transmitter type AKS 32R 1 – 5 volt pressure transmitter type AKS 32 0 – 20 (4 – 20) mA pressure transmitter type AKS 33			
	Temperature measurement Pt 1000 ohm / 0 °C NTC - 86 K from digital scroll / stream			
	From contact function E.g. to: Start / stop of regulation Monitoring of safety circuits General alarm function			
8 digital input				
Relay output to capacity control	4 pcs. SPDT (8 A): AC-1: 6 A (ohmic)			
	4 pcs. SPDT (8 A): AC-15: 4 A (inductive)			
	2 pcs. SPST (16 A): AC-1: 10 A (ohmic)			
	2 pcs. SPST (16 A): AC-15: 3.5 A (inductive)			
	2 pcs. Solid State. PWM for scroll -unload	<table border="1"> <tr> <td>I_{max.} = 0.5 A</td> </tr> <tr> <td>I_{min.} = 50 mA</td> </tr> <tr> <td>Leak < 1.5 mA</td> </tr> </table>	I _{max.} = 0.5 A	I _{min.} = 50 mA
I _{max.} = 0.5 A				
I _{min.} = 50 mA				
Leak < 1.5 mA				
2 Voltage output	0-10 V DC R _i = 1 kohm, Separate 24 V supply required			
Display output	For type MMIGRS2			
Data communication	Modbus for AK-SM 850			
Environments	-20 – 60 °C, During operations			
	-40 – 70 °C, During transport			
	20 – 80% Rh, not condensed			
Enclosure	No shock influence / vibrations			
Weight	IP20			
Mounting	0.4 kg			
Connection terminals	DIN-rail			
Approvals	max. 2.5 mm ² multi core EU Low Voltage Directive and EMC demands re CE-marking complied with LVD tested acc. EN 60730-1 and EN 60730-2-9 EMC-tested acc. EN61000-6-2 and 3			

Ordering

Description	Code no.	PSC
Pack Controller AK-PC 551 with built-in display	080G0281 (230 V) or 080G0283 (24 V)	1
Remote Display MMIGRS2	080G0294	1
Wire for Display	080G0076 (3 m)	1
Pressure transmitter AKS 32R for suction (1/4" flare -1 to 12 bar)	060G1036	1
Pressure transmitter AKS 32R for discharge (1/4" flare -1 to 34 bar)	060G0090	1
Plug with 5 m cable	060G1034	2
Temperature sensor AKS 11 for suction (3.5 m cable, -50 to 100°C)	084N0003	1
Temperature sensor AKS 21A for discharge (5 m cable, -70 to 180°C)	084N0008	1
Variable Speed drive FC-103 for lead compressor and condenser	Consult FC-103 configuration tool (drives.danfoss.com)	
Scroll Compressor		

AK-PC 651, Capacity controller

AK-PC 651 is used for capacity regulation of compressors and condensers in small refrigeration applications. A maximum of 10 compressors and one condenser can be regulated:

- One suction group + one condenser group
- One compressor group, max. 10 steps
- One condenser group, max. 8 steps

Features AK-PC 651

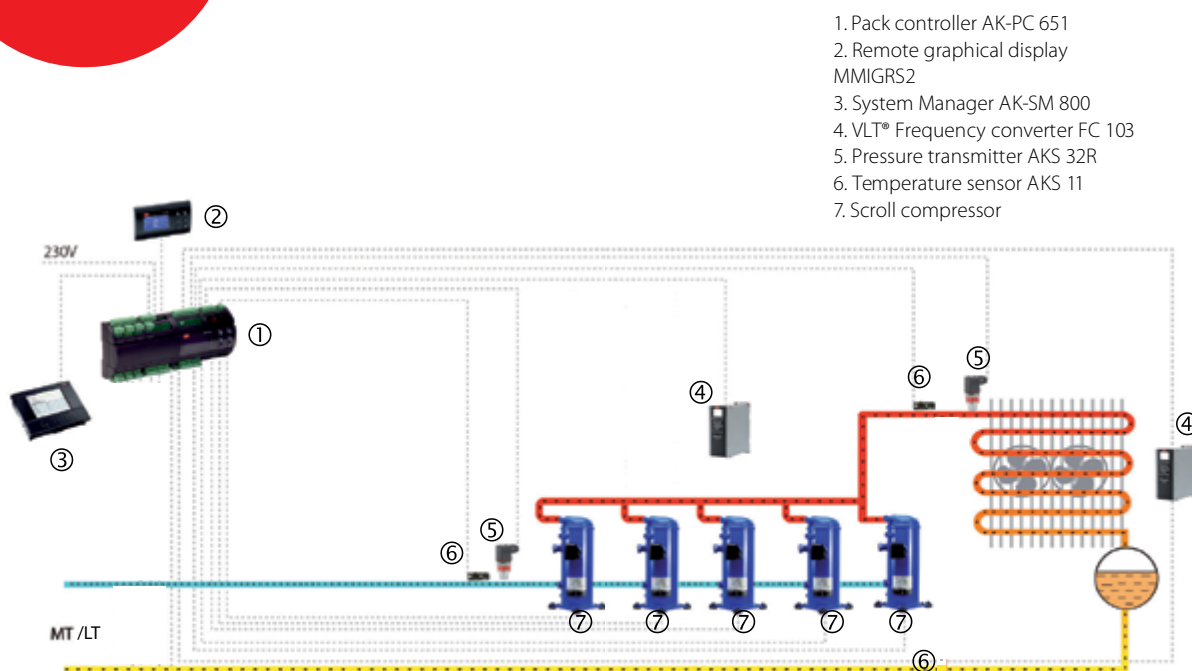

Facts

Benefits:

- Energy savings via:
 - optimisation of suction pressure
 - night time increase
 - floating condensing pressure
 - load limitation

Technical data and ordering

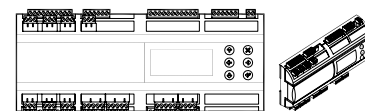

AK-PC 651

Capacity controller

Features	Description
Supply voltage	230 V AC (85 – 265 V) 50 / 60 Hz, 26 V A
10 analog Input	Pressure measuring: Ratiometric pressure transmitter type AKS 32R 1 – 5 volt pressure transmitter type AKS 32 0 – 20 (4 – 20) mA pressure transmitter type AKS 33 Temperature measurement Pt 1000 ohm / 0 °C NTC - 86 K from digital scroll / stream
18 digital input (14 for low voltage + 4 for high voltage or low voltage)	From contact function E.g. to: Start / stop of regulation Monitoring of safety circuits General alarm function
Relay output to capacity control	7 pcs. SPST (8 A): AC-1: 6 A (ohmic), AC-15: 4 A (inductive)
	4 pcs. SPDT (8 A): AC-1: 6 A (ohmic), AC-15: 4 A (inductive)
	2 pcs. SPDT (16 A): AC-1: 7 A (ohmic), AC-15: 3.5 A (inductive)
	2 pcs. Solid State. PWM for scroll -unload
4 Voltage output	0-10 V DC Ri = 1 kohm, Separate 24 V supply required
Display output	For type MMIGRS2
Data communication	Modbus for AK-SM 850
Environments	-20 – 60 °C, During operations
	-40 – 70 °C, During transport
	20 – 80% Rh, not condensed
Enclosure	No shock influence/vibrations
Weight	IP20
Mounting	0.8 kg
Connection terminals	DIN-rail
Approvals	max. 2.5 mm ² multi core EU Low Voltage Directive and EMC demands re CE-marking complied with LVD tested acc. EN 60730-1 and EN 60730-2-9 EMC-tested acc. EN61000-6-2 and 3

Ordering

Description	Code no.	PSC
Pack Controller AK-PC 651 with built-in display	080G0312	1
Remote Display MMIGRS2	080G0294	1
Wire for Display	080G0076 (3 m)	1
Pressure transmitter AKS 32R for suction (1/4" flare -1 to 12 bar)	060G1036	2
Pressure transmitter AKS 32R for discharge (1/4" flare -1 to 34 bar)	060G0090	1
Plug with 5 m cable	060G1034	3
Temperature sensor AKS 11 for suction (3.5 m cable, -50 to 100°C)	084N0003	1
Temperature sensor AKS 21A for discharge (5 m cable, -70 to 180°C)	084N0008	1
Variable Speed drive FC-103 for lead compressor and condenser	Consult FC-103 configuration tool (drives.danfoss.com)	
Scroll Compressor		

AK-SM 800 series, System manager

The System Manager controller from Danfoss is the global control and supervisory solution for the food retail industry. The System Manager uses the latest technology to provide the maximum benefit to the end user, both in terms of energy saving optimization, control options and full web user access.

Designed specifically for the food retail and food processing / handling market, the System Manager provides comprehensive functionality and support tools to cover small to large stores.



Facts

Benefits:

- Direct support to EM-800 (AKM not supported / needed)
- Supports centralized and decentralized control strategy; compatible with Danfoss case and pack controllers and Danfoss I/O
- Open XML data transfer allowing remote access to key system parameters

Design features:

- Active TFT SVGA color screen 800x600
- Front alarm status LED
- Removable keyboard panel (revealing connections)
- Easy access to USB flash drive
- Wall and panel mounting options
- Built in alarm relay output

Hardware capability features:

- Built in web server
- No back up battery required
- RS485 LonWorks®
- Ethernet
- EKC Modbus
- USB

Technical data and ordering

AK-SM 800 series

System manager

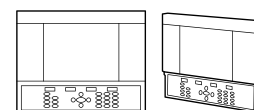

SM800 version comparison	AK-SM 810, SM820 - C-Store Version	SM850 - Refrig version	SM880 - Full version
Refrigeration Control			
All SM800 variants come with Centralized I/O and Pack / Case control options. EKC AK2 SLV FC103	Max 32 generic device support	Max 120 generic support	Max 120 generic support
Lighting Control			
All SM800 variants come with built in lighting control via I/O modules. The number of zones differ	10	30	30
HVAC			
Only the SM820 and SM880 support built in HVAC control via I/O	10	n/a	45
Alarms			
Capacity	250	250	250
Miscellaneous points (via IO modules)			
Relay (R), Sensor (S), ON / OFF (O / F), Variable (V)	R=20, S=20, O / F=20, V=20	R=70, S=80, O / F=70, V=70	R=70, S=80, O / F=70, V=70
Master control			
Po Optimization, Master Schedules, AKC ON <i>Note: Adaptive Defrost not currently supported</i>	X	X	X
Misc Calculations			
Boolean Logic statements	96	96	96
History			
The SM800 has the ability to record datapoints for history and view	600 points	600 points	600 points
Leak Detectors			
Refrigerant gas detectors (connected via AK I/O)	10	50	50
Energy Meters			
Pulse Input (via I/O module), Carlo Garvazi, Wattnode, Wattnode Plus Modbus, Veris Modbus	32	80	80
Service Tool Support			
Tunneling via front end (IP connection only)	X	X	X

Note:

AK-SM 810 doesnt have screen

Ordering

Type	Description	Options	Code no.
AK-SM 810	C-Store Refrigeration/HVAC/Lightning, No display, No buttons	Convenience Store with 32 device capacity	080Z4006
AK-SM 820	C-Store (Refrigeration / HVAC / Lighting)	Convenience Store version with 32 device capacity	080Z4004
AK-SM 850	Refrigeration (including lighting)	Refrigeration version with 120 device capacity	080Z4001
AK-SM 880	Full (Refrigeration / HVAC / Lighting)	Full store version with 120 device capacity	080Z4008
AK-SM 800AL	Alarm logger	AK-SM 8xx accessory	080Z4014

Smart store solution

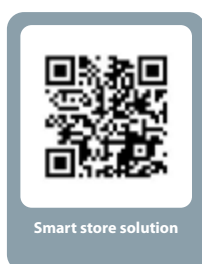

Optyma™ Control, Single / Three-phase

The Optyma™ Control is particularly suitable for the Optyma™ and Optyma™ Plus condensing units from Danfoss but is also compatible with other condensing units on the market. The control features an attractive new design and simple flexible programming.

It offers both control and protection in a single unit, thanks to the unique built-in differential magnetothermic circuit breaker, which guarantees safety by cutting the general power supply.

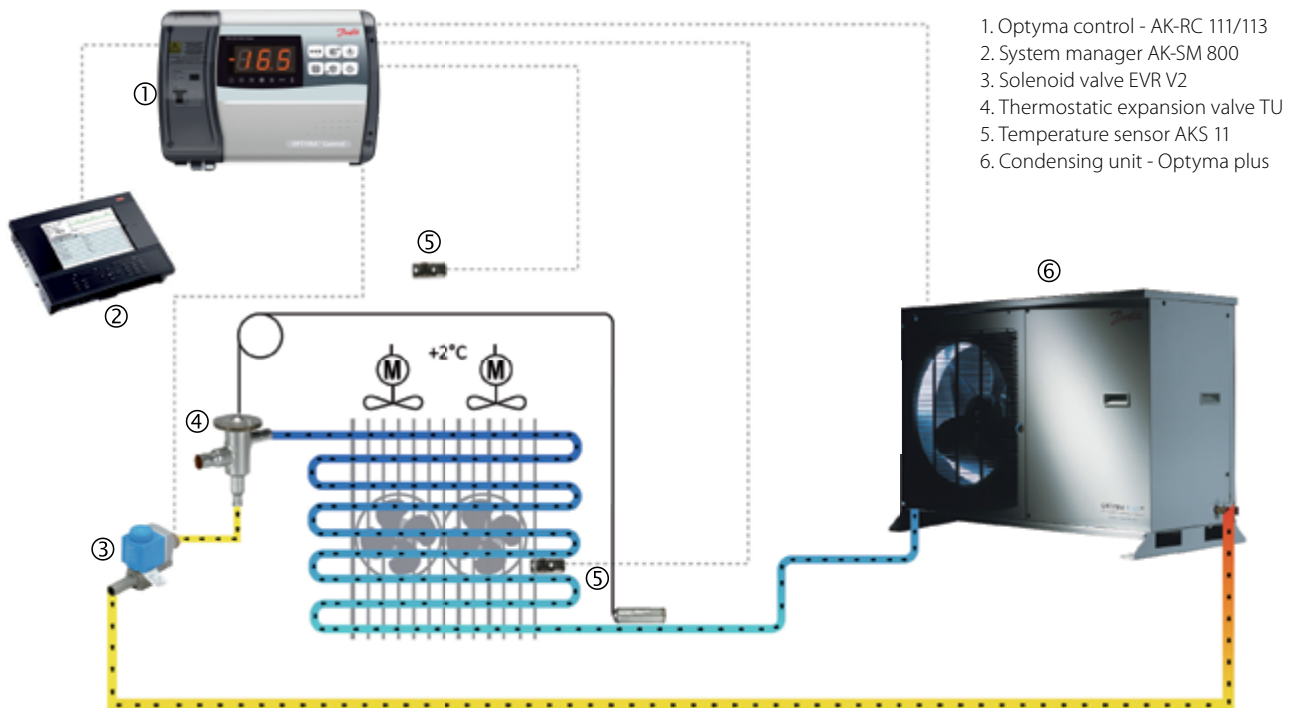

1. Optyma control - AK-RC 111/113
2. System manager AK-SM 800
3. Solenoid valve EVR V2
4. Thermostatic expansion valve TU
5. Temperature sensor AKS 11
6. Condensing unit - Optyma plus

Facts

Benefits:

- Direct control of defrosting elements, evaporator fans, room light with outputs directly connectable to the various units
- Standard and ADAP-KOOL® compatible Modbus data communication

Display & programming:

- LED indicators and large display show system status
- User-friendly keypad
- Display resolution to 0.1 °C

Protection:

- Automatic fuse protect the refrigeration unit
- Stylish ABS housing with transparent cover for access to the automatic fuse, all with an IP65 protection rating so that panel can be used outside the room

Technical data and ordering

Optyma™ Control, Single phase

Electronic controller

Power supply			
Voltage	230 V~ ± 10% 50/60 Hz		
Max power (only electronics)	~ 7 VA		
Rated current	16 A		
Climate conditions			
Working temperature	-5 – 50 °C		
Storage temperature	-10 – 70 °C		
Relative ambient humidity	Lower than 90% Hr		
General characteristics			
Type of sensors that can be connected	NTC 10K 1%		
Resolution	0.1 °C		
Sensor read precision	± 0.5 °C		
Read range	-45 – 99 °C		
Output characteristics			
Description	Installed relay	Card output characteristics	Note
Compressor	(Relay 30A AC1)	10 A 250 V~ (AC3) (2HP) (100000 cicli)	The sum of contemporary absorptions of these outputs has not to exceed 16 A
Defrost	(Relay 30A AC1)	16A 250 V~ (AC1)	
Fans	(Relay 16A AC1)	2.7 A 250 V~ (AC3)	
Room light	(Relay 16A AC1)	16 A 250 V~ (AC1)	
Aux 1 (free voltage contact)	(Relay 5A AC1)	5(3) A 250 V~	
Aux 2 (free voltage contact)	(Relay 5A AC1)	5(3) A 250 V~	
General electrical protection	Differential magnetothermic circuit breaker 16A		
	Id=300 mA		
	(Id=30 mA on request)		
	Disconnecting power 4.5 kA		
Dimension characteristics			
Dimensions	18.0 cm x 9.6 cm x 26.3 cm (HxPxL)		
Insulation and mechanical characteristics			
Box protection rating	IP65		
Box material	ABS self-extinguishing		
Type of insulation	Class II		

Technical data and ordering

Optyma™ Control, three phase

Technical Characteristics

Technical characteristics	OPTYMATM Control (4 HP)	OPTYMATM Control (7.5 HP)	
Box dimensions	400 x 300 x 135 mm	400 x 300 x 135 mm	
Weight	9 kg	10 kg	
Protection rating	IP 65	IP 65	
Power supply (3F+N+T)	400 V AC ±10% 50/60Hz	400 V AC ±10% 50/60Hz	
Load type	3-phase	3-phase	
Operating temperature	-5 – 40 °C	-5 – 40 °C	
Storage temperature	-25 – 55 °C	-25 – 55 °C	
Relative ambient humidity	from 30% to 95% RH w/out condensate	from 30% to 95% RH w/out condensate	
Altitude	< 1000 m	< 1000 m	
Main switch / general protection	4 poles magnetothermic 16A "D"	4 poles magnetothermic 25A "D"	
Interruption power	Icn=6kA / Ics=8kA / Icu=15kA	Icn=6kA / Ics=8kA / Icu=15kA	
Compressor protection	Adjustable motor circuit breaker	Adjustable motor circuit breaker	
Defrosting	Electrical	Electrical	
Status indicators	LED + display	LED + display	
Alarm signals	LED + buzzer	LED + buzzer	
Inputs			
Ambient probe	NTC 10K 1%	NTC 10K 1%	
Evaporator probe	NTC 10K 1%	NTC 10K 1%	
Door switch	Present	Present	
High/low pressure switch	Present	Present	
Kriwan® connection	Present	Present	
Compressor functioning mode selection	Pump-down / thermostat	Pump-down / thermostat	
Outputs			
Compressor	See motor circuit breaker thermal range relative to panel ID code	See motor circuit breaker thermal range relative to panel ID code	
Condenser fans output 1	800 W total	800 W total	(1 phase)
Condenser fans output 2 (separated)			
Evaporator fans	500 W (1 phase)	2000 W (1phase / 3 phases)	
Defrosting heaters	6000 W (AC1) eq. resistive load	9000 W (AC1) eq. resistive load	
Room light	800 W (AC1) resistive load	800 W (AC1) resistive load	
Solenoid valve	Present	Present	
Compressor oil heater	Present	Present	
Aux1	100 W	100 W	
Aux2	100 W	100 W	
Supervision system	Modbus	Modbus	

Ordering

Type	Description	Psc	Code no.
AK-RC 111	Optyma Control single-phase (2 HP) including two sensors	1	080Z3220
AK-RC 113	Optyma Control, three phase (4HP), including 2 sensors, 4.5 – 6.3 A	1	080Z3221
AK-RC 113	Optyma Control, three phase (4HP), including 2 sensors, 7 – 10 A	1	080Z3222
AK-RC 113	Optyma Control, three phase, (7.5HP), including 2 sensors, 11 – 16 A	1	080Z3226
AK-RC 113	Optyma Control, three phase, (7.5HP), including 2 sensors, 14 – 20 A	1	080Z3227

Note:

Sensor EKS 221 (spare part)- 084N3210

Pressure transmitters overview



Type	Standard	MBS 3000	MBS 3200	MBS 3100	MBS 1900
	Pulse-snubber	MBS 3050	MBS 3250	MBS 3150	
Industries	Transportation				
	Heating and sanitation				
	Machine and equipment				
	Energy				
Characteristics	Sensor technology	Piezo resistive	Piezo resistive	Piezo resistive	Piezo resistive
	Accuracy FS (typ)	± 0.5%	± 0.5%	± 0.5%	± 1%
	Max. measuring range	600 bar 9,000 psi	600 bar 9,000 psi	600 bar 9,000 psi	25 bar 362 psi
	Output signal	4 – 20 mA and absolute voltage	4 – 20 mA and absolute voltage	4 – 20 mA	4 – 20 mA Ratiometric
	Medium temperature	-40 – 85 °C -40 – 185 °F 	-40 – 125 °C -40 – 257 °F 	-40 – 85 °C -40 – 185 °F 	0 – 80 °C 32 – 176 °F
	Enclosure IP	IP65 IP67	IP65 IP67	IP65 IP67	IP65
	Wetted parts material	AISI 316L	AISI 316L	AISI 316L	AISI 304/AISI 316
	Housing material	AISI 316L, PA 6.6	AISI 316L, PA 6.6	AISI 316L, PA 6.6	AISI 316L
	Zero point and span adjustment				
	Marine approvals			•	
	ATEX approvals	Zone 2	Zone 2	Zone 2	UL
	UL HazLoc	Class 1, Div. 2	Class 1, Div. 2	Class 1, Div. 2	



Railways and marine



Industrial hydraulics, air compressors, water pumps and industrial engines



Electric power and wind turbines



Boiler and boiler room equipment, sterilisers and autoclaves, mobile hydraulic



MBS1200

MBS1300

MBS 5100

MBS 4510

MBS 9200

MBS 9300

EMP 2

MBS1250

MBS1350

MBS 5150



Thin film	Thin film	Piezo resistive	Piezo resistive	Piezo resistive	Piezo resistive	Piezo resistive
± 0.5%	± 0.5%	± 0.3%	± 0.5%	± 0.5% – ± 2% (depending on pressure range)	± 0.5% – ± 2% (depending on pressure range)	± 0.3%
2200 bar 32000 psi	2200 bar 32000 psi	600 bar 9,000 psi	25 bar 360 psi	250 mbar 3.62 psi	250 mbar 3.62 psi	400 bar 6,000 psi
4 – 20 mA Voltage Ratiometric		4 – 20 mA	4 – 20 mA	4 – 20 mA or Ratiometric	4 – 20 mA	4 – 20 mA
-40 – 125 °C -40 – 257 °F	-40 – 125 °C -40 – 257 °F	-40 – 85 °C -40 – 185 °F	-10 – 85 °C 14 – 185 °F	-40 – 85 °C -40 – 185 °F	-40 – 85 °C -40 – 185 °F	-40 – 100 °C -40 – 212 °F
IP67	IP67	IP65 IP67	IP65 IP67	IP65	IP65	IP67
17-4PH	17-4PH	AISI 316L	AISI 316L	AISI 316L	AISI 316L	AISI316L
AISI 304 or plastic	AISI 304 or plastic	AISI 316L, PA 6.6	AISI 316L, PA 6.6	AISI 316L, PA 6.6	AISI 316L, PA 6.6	Al
		•	•			•
		•			•	•
		Zone 2	Zone 2	Zone 2	Zone 2	Zone 2
		Class 1, Div. 2	Class 1, Div. 2			

Overview of temperature sensors



	MBT3250	MBT 3270	MBT 3560	MBT 153	MBT 5250	MBT 5252	MBT 5113	MBT 5116	
Segments	Transportation								
	Heating and sanitation								
	Machine and equipment								
	Energy								
Characteristics	Pt 100/Pt 1000	✓	✓		✓	✓	✓	✓	
	NTC/PTC	✓	✓		✓	✓	✓		
	Transmitter	mA/V d.c.							
	Transmitter as option						mA	mA	
	Measuring insert	Changeable	Fixed	Fixed	Fixed	Changeable	Changeable	Changeable	Changeable
	Medium temperature	-50 – 200 °C (-58 – 392 °F)	-50 – 300 °C (-58 – 572 °F)	-50 – 200 °C (-58 – 392 °F)	-50 – 200 °C (-58 – 392 °F)	-50 – 200 °C (-58 – 392 °F)	-50 – 400 °C (-58 – 752 °F)	-50 – 800 °C (-58 – 1472 °F)	-50 – 600 °C (-58 – 1112 °F)
	Enclosure	IP65 (NEMA 4)	IP65 (NEMA 4)	IP65/IP67 (NEMA 4/ NEMA 6)	IP67 (NEMA 6)	IP65 (NEMA 4)	IP65 (NEMA 4)	IP65 (NEMA 4)	IP65 (NEMA 4)
	Material protection tube	W.no. 1.4571 (AISI 316 Ti)	W.no. 1.4571 (AISI 316 Ti)	W.no. 1.4571 (AISI 316 Ti)	W.no. 1.4571 (AISI 316 Ti)	W.no. 1.4571 (AISI 316 Ti)	W.no. 1.4571 (AISI 316 Ti)	W.no. 1.4571 (AISI 316 Ti)	W.no. 1.4571 (AISI 316 Ti)
	Reaction time t0.5 in water (sec)	9 s	1.5 s	10 s	1 s	9 s	12 s	30 s	30 s
	Marine approvals					✓	✓	✓	✓



Marine and mobile hydraulics



Boiler and boiler room equipment, sterilisers and autoclaves



Electric power and wind turbines



Industrial hydraulics, air compressors, water pumps and industrial engines

MBS 3000, Compact pressure transmitter

The compact pressure transmitter MBS 3000 is designed for use in almost all industrial applications, and offers a reliable pressure measurement, even under harsh environmental conditions. The flexible pressure transmitter programme covers a 4 – 20 mA output signal, absolute and gauge (relative) versions, measuring

ranges from 0 – 1 to 0 – 600 bar and a wide range of pressure and electrical connections. Excellent vibration stability, robust construction, and a high degree of EMC/EMI protection equip the pressure transmitter to meet the most stringent industrial requirements.

Features MBS 3000



Facts

Benefits:

- 4 – 20 mA output signal
- Operating temperature: -40 – 85 °C
- Measuring range: 0 – 600 bar
- Standard pressure connection G ¼ A
- For use in severe industrial environments such as pumps, compressors, pneumatics and water treatment
- Wetted parts: stainless steel (AISI 316)

Technical data and ordering

MBS 3000

Compact pressure transmitter

Measuring range P_e (bar) ¹⁾	Pressure connection		Output signal		Code no.
	G 1/4 EN 837	M20 x 1.5	4 – 20mA	0 – 10V	
0 – 1	•		•		060G1113
0 – 2.5	•		•		060G1122
0 – 4	•		•		060G1123
0 – 6	•		•		060G1124
0 – 10	•		•		060G1125
0 – 10	•			•	060G1650
0 – 16	•		•		060G1133
0 – 25	•		•		060G1430
0 – 40	•		•		060G1105
0 – 100	•		•		060G1107
0 – 160	•		•		060G1112
0 – 250	•		•		060G1111
0 – 400	•		•		060G1109

1) Gauge/relative

MBS 3000

Spare parts & accessories



Type	Description	Code no.
Plug	EN 175301-803-A, Pg 9 plug	060G0008
	EN 175301-803-A, plug with 5 m cable	060G1034

Dimensions & weight

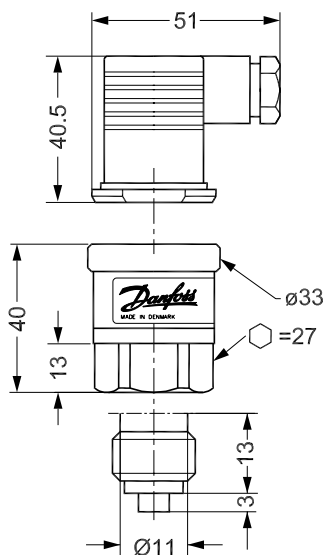

Weight: 0.17 kg

All dimensions in millimetres

MBS 3100, Compact pressure transmitter

The compact ship approved pressure transmitter MBS 3100 is designed for use in almost all marine applications, and offers a reliable pressure measurement, even under harsh environmental conditions.

The flexible pressure transmitter programme covers a 4 – 20 mA output signal, absolute and gauge (relative) versions, measuring ranges from 0 – 1 to 0 – 600 bar, plug and cable connections and a wide range of pressure connections.

Excellent vibration stability, robust construction, and a high degree of EMC/EMI protection equip the pressure transmitter to meet the most stringent marine requirements. The compact ship approved pressure

transmitter MBS 3100 is designed for use in almost all marine applications, and offers a reliable pressure measurement, even under harsh environmental conditions.

The flexible pressure transmitter programme covers a 4 – 20 mA output signal, absolute and gauge (relative) versions, measuring ranges from 0 – 1 to 0 – 600 bar, plug and cable connections and a wide range of pressure connections.

Excellent vibration stability, robust construction, and a high degree of EMC/EMI protection equip the pressure transmitter to meet the most stringent marine requirements.

Features MBS 3100



Facts

Benefits:

- 4 – 20 mA output signal
- Operating temperature: -40 – 85 °C
- Measuring range: 0 – 600 bar
- Standard pressure connection G ¼ A EN 837, G ¼ A, O-ring DIN 3852 G ½ A EN 837
- Available with all relevant marine approvals
- Suited for marine applications
- Wetted parts: stainless steel (AISI 316)

Technical data and ordering

MBS 3100

Compact pressure transmitter

Measuring range P_e (bar) ¹⁾	Pressure connection			Code no.
	G ¼ EN 837	G ¼ A, O-ring DIN 3852	G ½ A EN 837	
0 - 4	•			060G1367
0 - 6	•			060G1368
0 - 10	•			060G1369
0 - 40	•			060G1372
0 - 4		•		060G1463
0 - 6		•		060G1464
0 - 10		•		060G1465
0 - 40		•		060G1468
0 - 10			•	060G1471
0 - 16			•	060G1472

1) Gauge / relative

2) Sealed gauge

MBS 3100

Spare parts & accessories



Type	Description	Code no.
Plug	EN 175301-803-A, Pg 9 plug	060G0008
	EN 175301-803-A, plug with 5 m cable	060G1034
Adapters	G ½ female - ¼ flare male	060G1024

Dimensions & weight

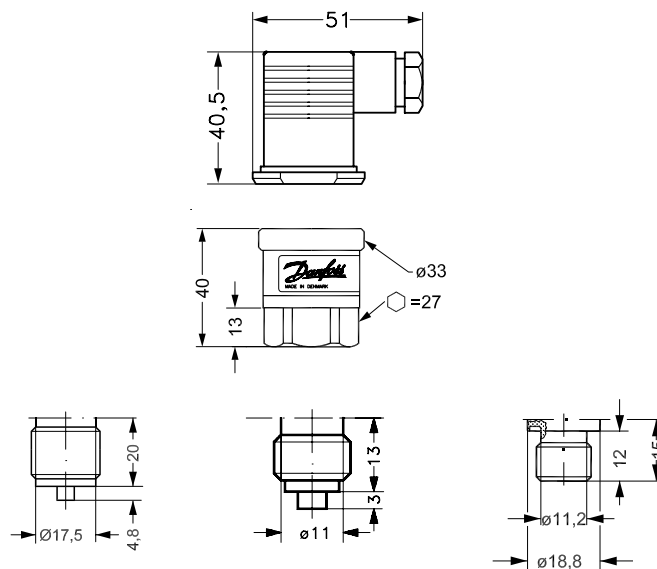

Weight: 0.2 kg

All dimensions in millimetres

MBS 5100, Pressure transmitter

The ship approved high accuracy pressure transmitter MBS 5100 is designed for use in almost all marine applications, and offers a reliable pressure measurement, even under harsh environmental conditions.

The pressure transmitter programme in block design covers a 4 – 20 mA output signal, absolute and gauge (relative) versions,

measuring ranges from 0 – 1 to 0 – 600 bar, zero point and span adjustment, plug connection and female/flange pressure connections.

Excellent vibration stability, robust construction, and a high degree of EMC/EMI protection equip the pressure transmitter to meet the most stringent industrial requirements.

Features MBS 5100



Facts

Benefits:

- 4 – 20 mA output signal
- Operating temperature: -40 – 85 °C
- Measuring range: 0 – 600 bar
- Pressure connection G 1/4 female
- Available with all relevant marine approvals
- Designed to meet the strict demands in marine equipment
- Wetted parts: stainless steel (AISI 316)

Technical data and ordering

MBS 5100

Pressure transmitter

Measuring range P_e (bar) ¹⁾	Pressure connection	Code no.
	G 1/4 with flange	
0 - 2.5	•	060N1033
0 - 4	•	060N1034
0 - 6	•	060N1035
0 - 10	•	060N1036
0 - 16	•	060N1037
0 - 25	•	060N1038
0 - 40	•	060N1039

1) Gauge / relative

MBS 5100

Spare parts & accessories



Type	Description	Code no.
Plug	EN 175301-803-A, Pg 9 plug	060G0008
	EN 175301-803-A, plug with 5 m cable	060G1034

Dimensions & weight

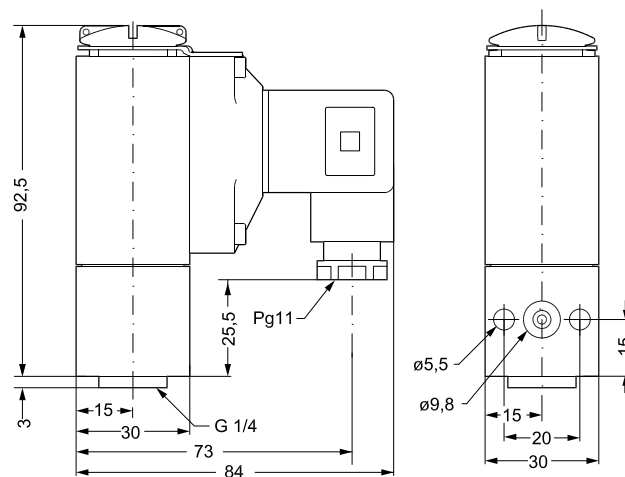

Weight: 0.4 kg

All dimensions in millimetres

AKS, Pressure transmitters

AKS pressure transmitters are used for commercial air-conditioning and for commercial and industrial refrigeration applications. They are made in stainless steel to be compatible with fluorinated and natural refrigerants and laser welding with no soft seals ensure hermetic tightness for decades.

AKS pressure transmitters utilize temperature calibrations methods and sensing technologies optimized for the refrigeration and air-conditioning segments.

Features AKS

Dedicated temperature calibration to increase accuracy when used for suction or discharge pressure regulation

Compact AKS 32R; AKS 3000 with solder or female flare pressure ports



Parts in touch with refrigerants are all laserwelded, free of soft gaskets

Facts

Benefits:

- Designed for precise and energy optimized control
- Robust design optimized for
 - air-conditioning
 - refrigeration plant
 - supermarket installation
 - natural refrigerants like CO₂ and R717
- Pressure ranges up to 159 bar
- High test pressure, ≥ 33 bar
- Available with 4 – 20 mA, 1 – 5 V DC or 10 – 90% Vs ratiometric signals
- Available with a variety of pressure connection, incl. 1/4 inch female flare with valve depressor and 3/8 inch solder connection, ensuring a 100% hermetic installation

Technical data and ordering

AKS 32R and AKS 2050 - With 10 – 90% ratiometric output signal

Pressure transmitters

Type	Pressure range (bar)	Max. overload pressure (bar)	Electrical connection	Pressure connection	Code no.
AKS 32R	-1 – 12	33	EN 175301-803-A without plug	7/16 – 20 UNF flare 1/4 in	060G1036
	-1 – 34	55	EN 175301-803-A without plug	7/16 – 20 UNF flare 1/4 in	060G0090
AKS 2050	-1 – 59	100	EN 175301-803-A without plug	Thread ISO 228/1 – G 3/8 A (BSP)	060G5750 ¹⁾
	-1 – 99	150	EN 175301-803-A without plug	Thread ISO 228/1 – G 3/8 A (BSP)	060G5751 ¹⁾
	-1 – 159	250	EN 175301-803-A without plug	Thread ISO 228/1 – G 3/8 A (BSP)	060G5752 ¹⁾
	-1 – 59	100	EN 175301-803-A without plug	1/4 – 18 NPT	060G6342
	-1 – 159	250	EN 175301-803-A without plug	1/4 – 18 NPT	060G6344

1) With pulse-snobber

AKS 32 and AKS 2050

Accessory

Type	Electrical connection	Comments	Code no.
Cable with plug	Plug 3 + E (female)	5 m cable	060G1034
Plug	EN 175301-803-A	Pg 9	060G0008

AKS 32 with 1 – 5 V output signal

Pressure transmitters

9 – 30 V DC supply voltage, accuracy 0.3% FS (typical), pressure reference gauge (relative)

Type	Pressure range (bar)	Max. overload pressure (bar)	Electrical connection	Pressure connection	Code no.
AKS 32	-1 – 12	33	EN175301-803-A Pg9 plug	7/16 – 20 UNF flare 1/4 in	060G2069
	-1 – 34	40	EN175301-803-A Pg9 plug	7/16 – 20 UNF flare 1/4 in	060G2071

AKS 33 with 4 – 20 mA output signal

Pressure transmitters

10 – 30 V DC supply voltage, accuracy 0.3% FS (typical), pressure reference gauge (relative)

Type	Pressure range (bar)	Max. overload pressure (bar)	Electrical connection	Pressure connection	Code no.
AKS 33	-1 – 12	33	EN175301-803-A Pg9 plug	7/16 – 20 UNF flare 1/4 in	060G2049
	-1 – 12	33	EN175301-803-A Pg 9 plug	G 3/8 EN 837	060G2105
	-1 – 12	33	EN175301-803-A Pg9 plug	1/4 – 18 NPT	060G2101
	-1 – 20	40	EN175301-803-A Pg9 plug	1/4 – 18 NPT	060G2102
	0 – 25	40	EN175301-803-A Pg9 plug	1/4 – 18 NPT	060G2115

AKS 3000 with 4 – 20 mA output signal

Pressure transmitters

10 – 30 V DC supply voltage, accuracy 1% FS (typical), pressure reference gauge (relative)

Type	Pressure range (bar)	Max. overload pressure (bar)	Electrical connection	Pressure connection	Code no.
AKS 3000	-1 – 12	33	EN175301-803-A Pg9 plug	7/16 – 20 UNF flare 1/4 in	060G1323
	0 – 30	55	EN175301-803-A Pg9 plug	7/16 – 20 UNF flare 1/4 in	060G1327
	0 – 40	100	EN175301-803-A Pg9 plug	7/16 – 20 UNF flare 1/4 in	060G1328
	0 – 60	200	EN175301-803-A Pg9 plug	1/4 – 20 NPT flare 1/4 in	060G1083

EKS / AKS, Temperature sensors

AKS temperature sensors are used for exacting applications within air-conditioning as well as commercial and industrial refrigeration applications. The Pt 1000 sensor element meets the DIN/EN 60751 class B requirements and ensures an accurate and reliable temperature signal applicable for regulation, safety and data logging.

EKS temperature sensors are a family of cost efficient temperature sensors based on thermistors with NTC or PTC characteristics which are used with Danfoss EKC controllers.



EN441 certified
AK-HS 1000
HACCP sensors

AKS 11 temperature sensor for reliable super heat control to optimize accuracy and process efficiency

AKS21 sensor system for controlling extreme high and low temperatures

Facts

Benefits:

- AKS 11 is designed for easy installation and optimized for demanding control functions like liquid injection control in evaporators where a reliable sensor is a must
- AKS 12 is the all-round cable temperature sensor to be used for plain temperature monitoring and control purposes
- AKS 21 is the ultimate sensor for -70 – 180 °C anywhere in the refrigeration plant and is available in various designs (cable and B-head) and with various accessories like sensor pockets
- AK-HS 1000 is the first choice for a temperature sensor for monitoring and HACCP data logging. The sensor design makes it simulate a refrigerated product what enable a realistic temperature signal is transmitted to a HACCP data logger
- EKS comes with PTC 1000 Ω (EKS 111), NTC 5000 Ω (EKS 211), or NTC 1000 Ω (EKS 221) with various cable lengths

Technical data and ordering

AK-HS - For monitoring and data logging in HACCP systems

Temperature sensors

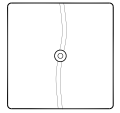

Type	Signal	Temperature range (°C)	Measuring accuracy	Enclosure	Cable length (m)	Code no.
AK-HS 1000	Pt 1000	-30 – 50	EN 60751 Class B	IP 54	5.5	084N1007

EKS - For measuring air temperatures

Temperature sensors

PTC characteristics matches controllers types EKC 101, EKC 201, EKC 301, CC and AK.

NTC characteristics matches controllers, types EKC and CC.



Type	Signal	Temperature range (°C)	Sensor tube	Electrical connection	Cable length (m)	Code no.
EKS 111	PTC 1000	-55 – 100	Round	Cable with pins	1.5	084N1178
	PTC 1000	-55 – 100	Round	Cable with pins	3.5	084N1179
	PTC 1000	-55 – 150	Round	Cable with pins	8.5	084N1168
EKS 211	NTC 5000	-40 – 80	Round	Cable	3.5	084N1221

EKS - For measuring temperatures

Temperature sensors

The sensor characteristics matches to OPTYMA room controllers and MCX unit controllers.

Type	Signal	Temperature range (°C)	Sensor tube	Electrical connection	Cable length (m)	Code no.
EKS 221	NTC 10000	-50 – 120	Round	Cable	3.5	084N3210

AKS - For measuring temperature

Temperature sensors

Recommended for accurate temperature measurement in superheating, food safety logs and other important applications



Type	Signal	Measure range [°C]	Sensor tube	Electrical connection	Cable length [m]	Code no.
AKS 12	Pt 1000	-40 – 80	Round	AMP plug	3.5	084N0039
	Pt 1000	-50 – 100	Concave	Cable	1.5	084N0036
AKS 11	Pt 1000	-50 – 100	Concave	Cable	8.5	084N0008
AKS 21A	Pt 1000	-70 – 180	Round	Cable	3.5	084N2007
AKS 21W	Pt 1000	-70 – 180	Sensor pipe	Cable	2.5	084N2017

Technical data and ordering

PT 1000 resistance

AKS 11, AKS 12, AKS 21

°C	ohm	°C	ohm
0	1000.0		1000.0
1	1003.9	-1	996.1
2	1007.8	-2	992.2
3	1011.7	-3	988.3
4	1015.6	-4	984.4
5	1019.5	-5	980.4
6	1023.4	-6	976.5
7	1027.3	-7	972.6
8	1031.2	-8	968.7
9	1035.1	-9	964.8
10	1039.0	-10	960.9
11	1042.9	-11	956.9
12	1046.8	-12	953.0
13	1050.7	-13	949.1
14	1054.6	-14	945.2
15	1058.5	-15	941.2
16	1062.4	-16	937.3
17	1066.3	-17	933.4
18	1070.2	-18	929.5
19	1074.0	-19	925.5
20	1077.9	-20	921.6
21	1081.8	-21	917.7
22	1085.7	-22	913.7
23	1089.6	-23	909.8
24	1093.5	-24	905.9
25	1097.3	-25	901.9
26	1101.2	-26	898.0
27	1105.1	-27	894.0
28	1109.0	-28	890.1
29	1112.8	-29	886.2
30	1116.7	-30	882.2
31	1120.6	-31	878.3
32	1124.5	-32	874.3
33	1128.3	-33	870.4
34	1132.2	-34	866.4
35	1136.1	-35	862.5
36	1139.9	-36	858.5
37	1143.8	-37	854.6
38	1147.7	-38	850.6
39	1151.5	-39	846.7
40	1155.4	-40	842.7
41	1159.3	-41	838.8
42	1163.1	-42	835.0
43	1167.0	-43	830.8
44	1170.8	-44	826.9
45	1174.7	-45	822.9
46	1178.5	-46	818.9
47	1182.4	-47	815.0
48	1186.3	-48	811.0
49	1190.1	-49	807.0
50	1194.0	-50	803.1

approx. 3.9 ohm/K

The tolerance of a Pt 1000 sensor is less than $\pm(0.3 + 0.005 T)$.

This translates into a temperature error of less than 0.5 degree for refrigeration control.

DGS, Gas sensor

DGS helps to comply to environmental F-Gas Regulations and / or Health and Safety requirements, on new or existing systems in:

- Supermarkets
- Process refrigeration plants
- Refrigerated storage and warehousing
- Special applications areas / zones



Utilizing
either Semi Conductor (SC) or Infrared (IR) technologies

Can be used
in stand-alone or integrated systems, where continuous real-time, automatic monitoring with Danfoss ADAP-KOOL® Refrigeration Control and Monitoring System and / or Building Management Systems is applied



RS485 Modbus
for data communication and integration into a complete ADAP-KOOL® system

Gives
quick and immediate response in detecting a wide range of different gases typically applied in Refrigeration and Air Conditioning systems

Facts

Typical Refrigerant gas applications include:

- Halocarbons: HFC's, HCFC's, CFCs.
- Carbon Dioxide (CO₂/R744)
- Hydrocarbons (e.g. R290)
- Other special application gases to customer request

- Sensing technology varies to make the best detection for a given gas, in terms of performance and cost. DGS IR is based on Infra-Red sensor technology, DGS SC is based on Semi-Conductor and DGS-PE is based on Pellistor

Technical data and ordering

DGS

Gas sensors

Features	Description		
Supply voltage	24 V DC \pm 20 % ; reverse polarity protected 24 V AC - 10 % / + 15 %		
Power Consumption (24V DC)	Max. 250 mA (5 VA)		
Digital input - Alarm acknowledge and test alarm - Alarm relay /fault relay	Potential-free contact 40 V AC/DC, 0.5 A, change-over contact (SPDT) Critical relay: Normally Closed (SIL II compliant), Warning relay: Normally Open		
Analog output signal	Proportional, overload and short-circuit proof, load \leq 500 Ohm Measuring range: 0-10 V / 2-10V / 0-20mA / 4-20mA		
Modbus Physical	5 V DC, 250 mA max. overload, short-circuit and reverse-polarity protected		
Enclosure rate	IP 65		
Humidity range	15 - 90 % RH not-condensing		
Burning behaviour	UL 94 V2		
Housing colour	Black		
Dimensions (W x H x D in mm)	94 x 130 x 57		
Installation	Wall mounting		
Cable entry	2 x M12 / 3 x M20		
Wire connection: Power supply, Modbus Analog output, Digital input Sensor head	Screw-type terminals 0.25 to 2.5 mm ² Screw-type terminals 0.25 to 1.3 mm ² 3-pin plug connector		
Sensor information	DGS-IR (CO₂)	DGS-SC (HFC)	DGS-PE (Propane)
Temperature range	-35 to +40°C	-30 to +50°C	-30 to +50°C
Response time T90	<120s	<40s	<10s
Recovery time, T0	90s	180s	120s
Maximum calibration interval	60 months	12 months	6 months
Measuring range	0 – 20,000ppm	20 – 2,000ppm	0 – 5,000ppm
Default alarm threshold	5,000ppm	500ppm	800ppm
Compliance	 IEC61010-1 ANSI/UL CAN/CSA-C22.2 No61010-1 RoHS		
Light (LED)	20 – 80% Rh, not condensed		
Buzzer	>85 dB (A) (0.1 distance) 2300 Hz		

Ordering

Type	Description	Code no.
DGS Sensors	DGS-SC HFC gr.1* + B&L	080Z2809
	DGS-SC HFC gr.2* + B&L	080Z2810
	DGS-SC HFC gr.3* + B&L	080Z2811
	DGS-PE Propane + B&L	080Z2812
	DGS-IR CO ₂ + B&L	080Z2807
	DGS-IR-CO ₂ 5 m + B&L	080Z2808

*HFC gr.1: R1234ze, R454c, **R1234yf**, R454a, R452A, R454b, R513a

HFC gr.2: R407F, R416a, R417a, R407A, R422a, R427a, R449A, R437a, **R134A**, R438a, R422D

HFC gr.3: R448A, R125, R404A, R32, R507A, R434a, R410A, R452b, **R407C**, R143b

Bold = calibration gas

Accessories:

Hand Held Service Tool : 080Z2820

Power Supply AK-PS075: 080Z0053

Note:

Hand held service tool is needed for installation (setup using modbus), calibration.

HGM, Multi-zone gas monitor

Multiple refrigerant gases and multiple area monitoring system for low level continuous monitoring of CFC, HCFC and HFC refrigerant gases used in most commercial refrigeration systems.

System design supports compliance to the refrigerant monitoring requirements of ANSI/BSR ASHRAE 15-2007 and ASHRAE safety code 34-2007.

Features HGM-400



Facts

Benefits:

- Detects, measures, and displays the level of refrigerant gas in the area being monitored
- Automatically logs up to 200 gas readings that can be printed/plotted for analysis
- Eliminates false alarms with use of non-dispersive IR source and sample draw system
- Extensive self-diagnostics, providing both visual and audible indications when a fault occurs

Design features:

- Optional models: LCD display, IP65 enclosure, EExd (Explosion)
- Two digital outputs low level and high level alarm
- Manual or automatic alarm reset optional
- Battery powered, providing 8-12 hours of operation

Application:

- Commercial refrigeration
- Cold Storage Facilities
- Supermarket/Hypermarket
- Distribution Centres
- Air Conditioning
- Chillers

Technical data and ordering

HGM-MZ

Specification

Specification	Description
Product type	Multiple refrigerant gases and multiple area monitoring system for low level continuous monitoring of CFC, HCFC and HFC refrigerant gases used in most commercial refrigeration systems. System design supports compliance to the refrigerant monitoring requirements of ANSI/ BSR ASHRAE 15-2007 and ASHRAE Safety Code 34-2007
Sensitivity	All gases 1ppm
Measuring range	All gasses 0 to 10.000 ppm
Accuracy ¹	±1 ppm ±10% of reading from 0-1000ppm (R11, R22, and R113 ±10ppm ±15% of reading 0-1000ppm)
Gas library	CFC: HFP, R-11, R-12, R-113, R-114, R-502; HFC: R125, R-134a, R236FA, R245Fa, R32, R-404a (HP62), R-407a, R-407c (AC9000), R-410a (AZ20), R422a, R422d, R427a, R-507 (AZ50), R-508b (SUVA95) HCFC: R-123, R-124, R21, R-22, R227, R-23, R-401a (MP39), R-402a (HP80), R 402b (HP81), R-408a, R-409a, R-500, R-503; Halon: H1211, H1301, H2402; Other: FA188, FC72, H1234YF, N1230, R424A, R426A, R438A, CUSTOM.

General Multi-zone

Specification

Specification	Description
Size (H x W x D)	12.23" x 13.7" x 4.96" (31.06cm x 34.80cm x 12.60cm)
Weight	15lbs. (6.8kg)
Sampling mode	Automatic or manual (hold)
Re-zero	Auto or on zone change
Response time	5 to 315 seconds - depending on air line length and number of zones
System noise	Less than 40dB(A) @ 10ft (3m)
Monitoring distance	1.200ft (366m) maximum for combined length of sample + exhaust tubing (each zone)
Conditioned signal	Dual optional 4-20mA DC isolated outputs. Channel 1 = zone area, Channel 2 = PPM
Alarms	Four SPDT alarm contacts rated 2A at 250VAC (inductive) 5A at 250VAC (resistive). Three are assigned to PPM level alarms, one assigned to system faults.
Communications	Full two-way communications with Remote Display Module or Building Management System via RS 485 serial interface. RS-232C communications port standard
Power safety mode	Fully automatic system reset. All programmed parameters retained
Operating temperature	32 to 122°F (0 to 50°C)
Ambient humidity	5 % to 90% RH (non-condensing)
AC power	100 to 240VAC, 50/60Hz, 20W

Technical data and ordering

DHGM

Gas monitor

DANFOSS HALOGEN GAS MONITOR (DHGM-8 zone)	080Z2151
Components included	Qty
DHGM Unit	1
Line End Dust filter	8
Purge/ Fresh Air Carbon Filter	1

Note: Tubing not supplied

DHGM

Components

DHGM components (16 zone)	LP-DHGMKIT
Components included	Qty
Line End Dust filter	3
STRAIGHT ¼ X ¼ BSP"	2
EQUAL CROSS ¼ PUSH IN	3
Plastic Silencer ¾ BSPP "WHITE"	10
Straight ¼" x ¾ BSP	10
Socket ¾ - ¾	2
¾ BSP F/F Elbow	8
Straight 6mm x ¼ BSP	2
¼ Mini filter	2
¼ EQUAL TEE CONNECTOR	5
Black 1" brackets	25
PU tubing 6mm - 300 meters rolls	2

Note: Individual Components not sold separately.

080Z2154 - 4-20ma Output card required for all Danfoss frontend controllers

DHGM

Maintenece kit

DHGM Maintenece kit	LP-DHGM8M
Components included	Qty
End of Line Filters	23
Hyperbolic Filter	1
Water Trap: Internal Filter Element	2
Purge/ Fresh Air Carbon Filter	1

DHGM

Spares

Spares	
4 port manifold	LP3015-5072
5 port manifold Block w/ Purge	LP3015-5080
HGM Sampling Pump with connector	LP3015-5176
Rabbit Processor Board	LP3015-5546
Replacement Manifold fitting	LP3015-5753
Charcoal filter	C01680417

PGM-IR, Portable gas monitor

The PGM-IR is designed to detect, measure, and display the concentration of refrigerant gas in the area being monitored. To ensure accurate gas measurements, the monitor self-zeroes every four minutes using an external supply of fresh air provided by activated carbon filtering.

During normal operation the Refrigerant Monitor displays both the current gas level and the peak gas level detected on its front LCD panel.

The monitor retains a log of previous readings that can be easily accessed at a later time for analysis.

Features PGM-IR



Facts

Benefits:

- Detects, measures, and displays the level of refrigerant gas in the area being monitored
- PGM-Halogen gas monitor: Measures all gases up to 10,000 ppm with a sensitivity of 1 ppm-
- PGM-CO2 gas monitor: CO2 detection range of 20 to 100,000ppm, relative to ambient.
- Automatically logs up to 200 gas readings that can be printed/plotted for analysis

- Eliminates false alarms with use of non-dispersive IR source and sample draw system
- Visual and audible gas alarm indicators that are turned ON when the detected gas level exceeds a user defined trip-point
- Extensive self-diagnostics, providing both visual and audible indications when a fault occurs
- Battery powered, providing a minimum of 8 hours of operation

Application:

- Commercial refrigeration
- Cold Storage Facilities
- Supermarket/Hypermarket
- Distribution Centres
- Air Conditioning
- Chillers

Technical data and ordering

PAGM Halogen

Specification

Specification	Description
Gas Library	<p>CFC: R-11, R-12, R-113, R-114, R-502, HFP</p> <p>HFC: R-404a (HP62), R-407a, R-407c (AC9000), R-134a, R-410a (AZ20), R-507 (AZ50), R-508b (SUVA95), R-236FA, R-125, R-245Fa, R-422a, R-422d, R-427a, R-424a, R-426a, R-438a, R-407F, R-32</p> <p>HCFC: R-22, R-123, R-124, R-500, R-503, R-401a (MP39), R-402a (HP80), R-402b (HP81), R-408a, R-409a, R-23, R-21, R-227</p> <p>HALON: H1301, H2402, H1211</p> <p>Other: FA188, FC72, N1230, H1234YF, H1234ZE, N7100, N7200, N7300, N7600</p>
Measuring Range	All gases 0 to 10,000 ppm
Warm-Up Time	5 minutes
Detector Type	Infrared, Non-Dispersive
Sensitivity	1 ppm
Accuracy	±1 ppm ±10% of reading from 0-1000 ppm R11, R22 and R113 are ±10 ppm ±15% of reading from 0-1000 ppm
Response Time	90% of response within 5 seconds; 100% in 7 seconds
Temperature Drift	1.5 ppm per degree C between purge cycles
System Noise	Less than 40 dB (A) at 10ft (3 m)
Operating Temp	32 to 122°F (0 to 50°C)
Ambient Humidity	5 to 90% RH (non-condensing)
Altitude Limit	6,562 ft (2,000 m)
Power	DC power pack, provides a minimum of 8 hours of operation
Power Consumption	15 Watts
Front panel	<p>3 indicator lights:</p> <p>ON Green LED flashes during warm-up, then glows steady during normal operation.</p> <p>FAULT Yellow LED flashes when there is a system fault.</p> <p>ALARM Red LED flashes when the gas level is above its alarm setting</p>
Audible Alarm	Internal audible alarm programmable for any of the following conditions: OFF, FAULT/ ALARM, ALARM
Dimensions (D x L x W)	9.0 x 14.5 x 5.0 inches (229 x 368 x 127 mm)
Weight	Less than 9lbs (4 kg) including battery

Technical data and ordering

PAGM CO2

Specification

Specification	Description
Gas Detected	CO ₂ (R744)
Measuring Range	20 to 100,000 ppm (10% vol.)
Warm-Up Time	5 minutes (300 seconds)
Detector Type	Infrared, Non-Dispersive
Display Resolution	1 ppm
Accuracy	±1 ppm ±10% of reading from 0-10,000 ppm
Response Time	90% of response within 5 minutes
System Noise	Less than 40dB (A) at 10ft (3 m)
Operating Temperature	32 to 122°F (0 to 50°C)
Ambient Humidity	5 to 90% RH (non-condensing)
Altitude Limit	6,562 ft (2,000 m)
Power	DC power pack, provides a minimum of 8 hours of operation
Power Consumption	15 Watts maximum
Front panel	3 indicator lights: ON Green LED flashes during warm-up, then glows steady during normal operation FAULT Yellow LED flashes when there is a system fault ALARM Red LED flashes when the gas level is above its alarm setting
Audible Alarm	Internal audible alarm programmable for any of the following conditions: OFF, FAULT/ ALARM, ALARM
Dimensions (D x L x W)	9.0 x 14.5 x 5.0 inches (229 x 368 x 127 mm)
Weight	Less than 9lbs (4 kg) including battery
Warranty	2 years from date of shipment

Technical data and ordering

PGM-IR

PAGM models

PAGM FOR CO2	080Z2148
PAGM FOR HALOGEN GAS	080Z2149

PGM-IR

Maintenece kit

Maintenece kit	LP-DHGM-MM
Components included	Qty
Coalescing inline Filter Element	1
Purge/ Fresh Air Carbon Filter	1
HYDROPHOBIC FILTERS	2

PGM-IR

Spare parts & accessories

Spares	
LP3015-5808	Battery Charger only
LP3015-5743	PAGM Battery Pack
LP3015-4239	Replacement Pump
LP3015-4721	Replacement IR Sensor Kit

Secop reciprocating compressors produced for Danfoss - Direct current

BD range is the leading and widest AC / DC compressor range tailored for cooling on the move.

The excellent performance of the BD series safeguards food, medical and telecommunication.



Facts

Applications:

- 12 / 24 V DC mobile refrigerators and freezers
- 12 V DC LBP / MBP van cooling boxes
- 12 / 24 V DC HBP telecommunication systems

Refrigerants:

- R134a

Capacity range:

- 32 - 274 W

Segment usage:

- Refrigeration MT

Benefit:

- Operation under extreme conditions
- Minimal energy consumption
- Portable beyond traditional limits
- Application possible at extreme voltage rate

Technical data and ordering

R134a

Application	Compressors model	Kit ordering code		Cooling capacity (W) ¹⁾	Electrical equipment *	
		with DC electronic module	with AC / DC electronic module		DC Electronic module (spare - EMI)	AC / DC electronic module (spare)
LBP / MBP	BD35F	195B0722	195B0744	35.9	101N0212	101N0510
	BD50F	195B0723	-	52.5	101N0212	101N0510
	BD80F	195B0742	-	78	101N0390	-
	BD250GH	195B0748	-	78	101N0390	-

AC plug for BD compressor - 105N9531

BD Remote kit with 75cm. Cable - 105N9100

*- Electrical equipment are spares. Generally these are supplied along with compressors in kit ordering code.

1) Condensing temperature : 55°C, Evaporating temp: -25°C, Suction gas temp: 32°C, Liquid temperature: 55°C

01

02

03

04

05

06

07

08

09

10

11

12

13

14

15

Secop reciprocating compressors produced for Danfoss- Light commercial

Specially optimised for use in household and light commercial applications, hermetic reciprocating compressors from Secop for Danfoss provide high cooling capacity in an energy saving design.

Compressor models are available for R134a, R290, R404A / R507A and R600a, for cooling needs from 20W to 6kW.

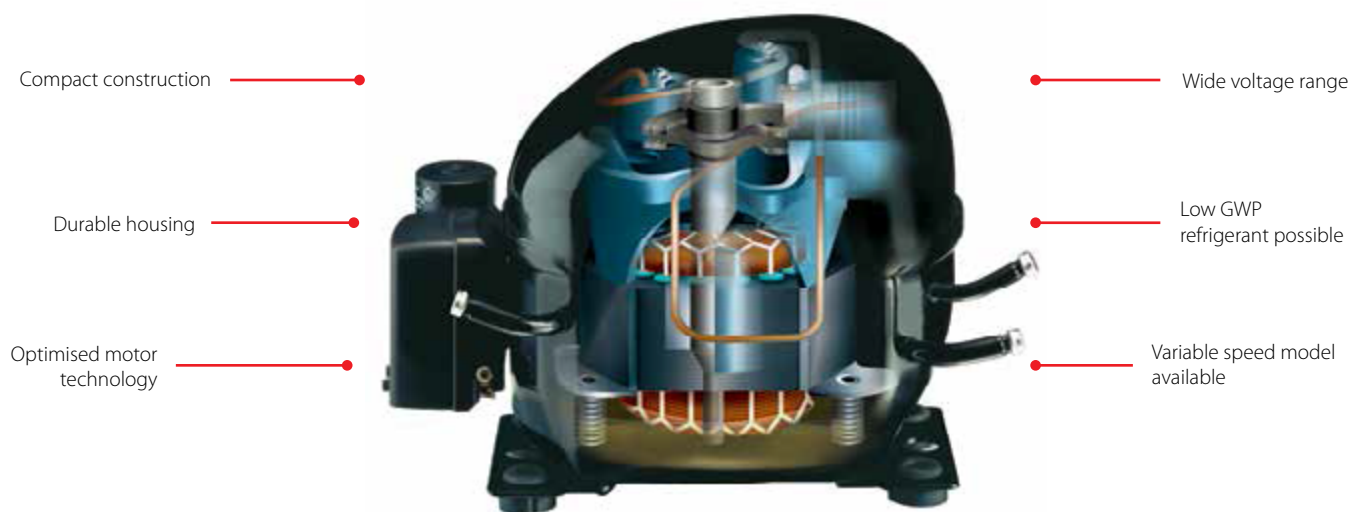

Compact construction

Wide voltage range

Durable housing

Low GWP refrigerant possible

Optimised motor technology

Variable speed model available

Facts

Applications:

- Laboratory and medical equipment
- Compressed air dryers
- Glass door merchandisers
- Display cabinets
- Fridges and freezers
- Ice cream cabinet
- Vending machines
- Drink dispensers
- Ice making machines
- Bottle coolers
- Heat pumps
- Milk cooling tanks

Refrigerants:

- R134a
- R290
- R404A
- R507A
- R600a

Capacity range:

- 20-6k W

Segment usage:

- Household and light commercial application

Benefit:

- Easy installation
- Low noise and high energy efficiency
- Robust in tough operating conditions
- Immune to unstable power supply
- Environmentally friendly solutions Portable beyond traditional limits
- Application possible at extreme voltage rate

Technical data and ordering

R134a

Application	Compressors model	Compressor kit with HST equipment	Capacity (W)	Displacement (cm ³)	Electrical equipment *					
					LST(RSIR)	HST (CSIR)		HST (CSR)	LST / HST	
					PTC Starting device	Starting relay	Starting capacitor	Starting unit	Cord relief	Cover
					spades	spades		spades		
6.3 mm	6.3 mm	6.3 mm	6.3 mm							
HBP / MBP / LBP ¹⁾	PL35G	195B0245	28	2.00	103N0011	117U6021	117U5014	-	103N1010	-
	TL3G	195B0006	41	3.13	103N0011	117U6009	117U5014	-	103N1010	103N2010
	TL4G	195B0008	58	3.86	103N0011	117U6004	117U5014	-	103N1010	103N2010
	TL5G	195B0011	79	5.08	103N0011	117U6000	117U5014	-	103N1010	103N2010
	FR6G	195B0023	83	6.23	103N0011	117U6000	117U5015	-	103N1010	103N2010
	FR7.5G	195B0024	99	6.93	103N0011	117U6001	117U5015	-	103N1010	103N2010
	FR8.5G	195B0026	123	7.95	103N0011	117U6015	117U5015	-	103N1010	103N2010
	FR10G	195B0027	136	9.05	103N0011	117U6010	117U5015	-	103N1010	103N2010
	FR11G	195B0028	170	11.15	103N0011	117U6010	117U5015	-	103N1010	103N2010
	SC10G	195B0043	113	10.29	-	117U6002	117U5017	-	-	-
	SC12G	195B0050	175	12.87	-	117U6003	117U5017	-	-	-
	SC15G	195B0053	164	15.28	-	117U6005	117U5017	-	-	-
	SC18G	195B0059	283	17.69	-	117U6019	117U5017	-	-	-
	SC21G	195B0636	333	20.95	-	-	-	117-7029	-	-
SC12/12G	195B0051	350	2 × 12.87	-	117U6003	117U5017	-	-	-	
LBP ²⁾	PL50F	195B0001	40	2.50	-	117U6021	117U5014	-	103N1010	-
	TL3FX	195B0005	54	3.13	103N0011	117U6007	117U5014	-	103N1010	103N2010
	TL5FX	195B0009	82	5.08	103N0011	117U6004	117U5014	-	103N1010	103N2010
	TLS5FX	195B0010	98	5.08	103N0011	117U6004	117U5014	-	103N1010	103N2010
	TLS6F	195B0012	104	5.70	103N0011	117U6004	117U5014	-	103N1010	103N2010
	TLS7FX	195B0224	120	6.49	103N0011	117U6000	117U5014	-	103N1010	103N2010
	NL6FX	195B0165	110	6.13	103N0011	117U6004	117U5015	-	103N1010	103N2010
	NL7FX	195B0176	136	7.27	103N0011	117U6000	117U5015	-	103N1010	103N2010
	NL7FK	195B0091	136	7.27	103N0011	117U6000	117U5015	-	103N1010	103N2010
	NL9FK	195B0092	155	8.35	103N0011	117U6001	117U5015	-	103N1010	103N2010
	NL11FX	195B0093	200	11.15	103N0011	117U6002	117U5015	-	103N1010	103N2010
	SC15FX	195B0052	230	15.28	-	117U6003	117U5017	-	-	-
	SC18FX	195B0057	280	17.69	-	117U6005	117U5017	-	-	-
SC21FX	195B0047	335	20.95	-	117U6019	117U5017	-	-	-	
MBP ³⁾	NL7.3MF	195B0370	304	7.27	103N0011	117U6016	117U5015	-	103N1010	-
	NL10MF	195B0275	441	10.10	103N0011	117U6022	117U5018	-	103N1010	-
	GS26MFX	195B0433	1266	26.30	-	-	-	117-7055	-	-
	GS34MFX	195B0435	1648	33.80	-	-	-	117-7056	-	-
HBP ⁴⁾	FR7GH	195B0167	525	6.93	-	117U6016	117U5015	-	103N1010	-
	SC10GH	195B0142	762	10.29	-	117U6005	-	-	-	-
	SC15GH	195B0144	1139	15.28	-	117U6011	-	-	-	-
	SC18GHX	195B0648	1310	17.69	-	-	-	-	103N9100	103N2008

Note: LST- Low starting torque= PTC relay only

HST- high starting torque= starting relay + capacitor.

*- Electrical equipment are spares. Generally these are supplied along with compressors in kit ordering code.

1)- Condensing temperature : 55°C, Evaporating temp: -25°C, Suction gas temp: 32°C, Liquid temperature: 55°C

2)- Condensing temperature : 55°C, Evaporating temp: -25°C, Suction gas temp: 32°C, Liquid temperature: 55°C

3)- Condensing temperature : 55°C, Evaporating temp: -10°C, Suction gas temp: 32°C, Liquid temperature: 55°C

4)- Condensing temperature : 55°C, Evaporating temp: 5°C, Suction gas temp: 32°C, Liquid temperature: 55°C

Technical data and ordering

R404A & R507

Application	Compressors model	Compressor kit with HST equipment	Cooling capacity (W)	Displacement	Electrical equipment *				
					HST (CSIR)		HST (CSR)	LST / HST	
					Starting relay	Starting capacitor	Starting device	Cord relief	Cover
					spades		spades		
cm ³	6.3 mm	6.3 mm	6.3 mm						
LBP ¹⁾	TL4CL	195B0021	142	3.86	117U6000	117U5014	-	103N1010	103N2010
	FR6CL	195B0031	243	6.23	117U6015	117U5015	-	103N1010	103N2010
	FR7.5CL	195B0398	262	6.93	117U6016	117U5015	-	103N1010	103N2010
	FR8.5CL	195B0038	290	7.95	117U6010	117U5015	-	103N1010	103N2010
	NL7CLX	195B0350	340	7.27	117U6002	117U5015	-	103N1010	103N2010
	SC10CLX	195B0074	360	10.29	117U6005	117U5017	-	103N1004	103N2008
	SC12CL	195B0076	637	12.87	117U6005	117U5017	-	103N1004	103N2009
	SC15CL	195B0088	780	12.87	-	117U5017	-	103N1004	103N2008
	SC18CL	195B0066	995	17.68	117U6013	117U5012	-	103N1004	103N2009
	SC21CLX	195B0640	813	20.95	-	-	117-7027	103N1004	103N2009
	GS26CLX	195B0427	1240	26.3	-	-	117-7056	-	-
	GS34CLX	195B0439	1715	33.8	-	-	117-7074	-	-
	SC15/15CL	195B0109	1230	2X15.28	117U6019	117U5017	-	103N1004	103N2009
	SC21/21CL	195B0644	1636	2X20.95	-	-	117-7027	103N1004	103N2009
MBP ²⁾	NF7MLX	195B0443	635	7.27	117U4139	117U5018	-	2x117U0349	117U1021
	SC10MLX	195B0345	855	10.29	117U6011	117U5017	-	103N1004	103N2008
	SC12MLX	195B0323	1038	12.87	117U6011	117U5017	-	103N1004	103N2008
	SC15MLX	195B0391	1285	15.28	117U6013	117U5012	-	103N1004	103N2009
	SC18MLX	195B0652	1497	17.68	-	-	117-7027	103N1004	103N2009
	SC18MLX.3	195B0653	1557	17.68	-	-	117-7027	103N1004	103N2009
	GS21MLX	195B0436	1748	21.2	-	-	117-7070	-	-
	GS26MLX	195B0437	2254	26.3	-	-	117-7072	-	-
	GS34MLX	195B0438	2953	33.8	-	-	117-7056	-	-
HBP ³⁾	TL4DL	195B0166	527	3.86	117U6001	117U5014	-	103N1010	103N2010
	FR6DL	195B0032	840	6.23	117U6010	117U5015	-	103N1010	103N2010
	SC10DL	195B0075	1450	10.29	117U6005	117U5017	-	103N1004	103N2009
	SC12DL	195B0077	1890	12.87	117U6019	117U5017	-	103N1004	103N2009
	SC15DLX	195B0641	2210	15.28	117U6019	117U5017	-	103N1004	103N2009
	SC10/10DL	195B0111	2900	2X10.29	117U6005	117U5017	-	103N1004	103N2009
	SC12/12DL	195B0112	3780	2X12.87	117U6019	117U5017	-	103N1004	103N2009

1)- Condensing temperature : 45°C, Evaporating temp: -25°C, Suction gas temp: 32°C, Liquid temperature: 45°C

2)- Condensing temperature : 45°C, Evaporating temp: -10°C, Suction gas temp: 32°C, Liquid temperature: 45°C

3)- Condensing temperature : 45°C, Evaporating temp: 5°C, Suction gas temp: 32°C, Liquid temperature: 45°C

*- Electrical equipment are spares. Generally these are supplied along with compressors in kit ordering code.

Technical data and ordering

R600a

Application	Compressors model	Compressor kit with HST (electrical equipments)	Capacity (W) ¹⁾	Displacement (cm ³)	Electrical Equipment				
					LST (RSIR) & (RSCR)		Run capacitor	LST / HST	
					PTC Starting device	PTC device with run capacitor connector	Optional or compulsory (refer data sheet)	Cord relief	Cover
					spades				
					6.3 mm	4.8 mm	6.3 mm		
LBP / MBP	TLES9KK.2	195B0228	110	8.83	103N0011	103N0021	117-7117	103N1010	103N2010
LBP	NLX13KK.2	195B0456	167	13.25	-	103N0021	-	103N1010	103N2010
	NLX15KK.2	195B0506	192	14.65	-	103N0021	-	103N1010	103N2010
	NLE15KK.4	195B0374	190	14.65	103N0011	103N0021	117-7117	103N1010	103N2010

1)- Condensing temperature: 45°C, Evaporating temp: -25°C, Suction gas temp: 32°C, Liquid temperature: 55°C

R290

Application	Compressors model	Compressor kit with HST (electrical equipments)	Capacity (W) ¹⁾	Displacement	Electrical Equipment							
					LST (RSIR)	LST(RSCR)	Run capacitor	HST (CSIR)		LST / HST		
					PTC Starting device w/o run capacitor connector	PTC device with run capacitor connector	1 optional 2 compulsory	Starting relay	Starting capacitor	Cord relief	Cover	
					cm ³							
					6.3 mm	4.8 mm	6.3 mm	6.3 mm	6.3 mm			
LBP / MBP	DLE7.5CN	195B0728	290	0.27	103N0011	103N0021	117-7117	117U7002	117U5015	103N1010	103N2010	
LBP	SC12CNX.2	195B0458	45	2.87	-	-	-	-	117U5017	-	-	
	SC18CNX.2	195B0489	689	7.69	-	-	-	-	117U5017	-	-	

1)- Condensing temperature: 45°C, Evaporating temp: -25°C, Suction gas temp: 32°C, Liquid temperature: 45°C

Accessories

Description	Code
Bolt joint (M6 metric)	118-1917
Snap on (Ø 7.3 mm)	118-1919
Clip	118-3585
Steel Pin	118-3586
Washer Ø 21 x Ø 8.1 mm x 0.9 mm	118-3588
Rubber grommet 16 mm	118-3661
Rubber grommet 19 mm	118-3666

Wiring diagram of small compressors

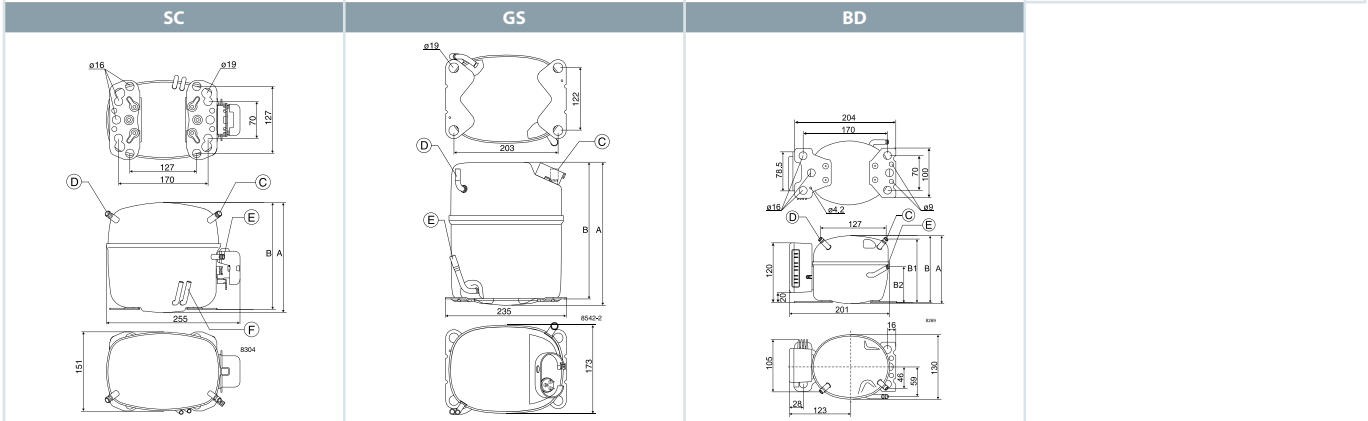
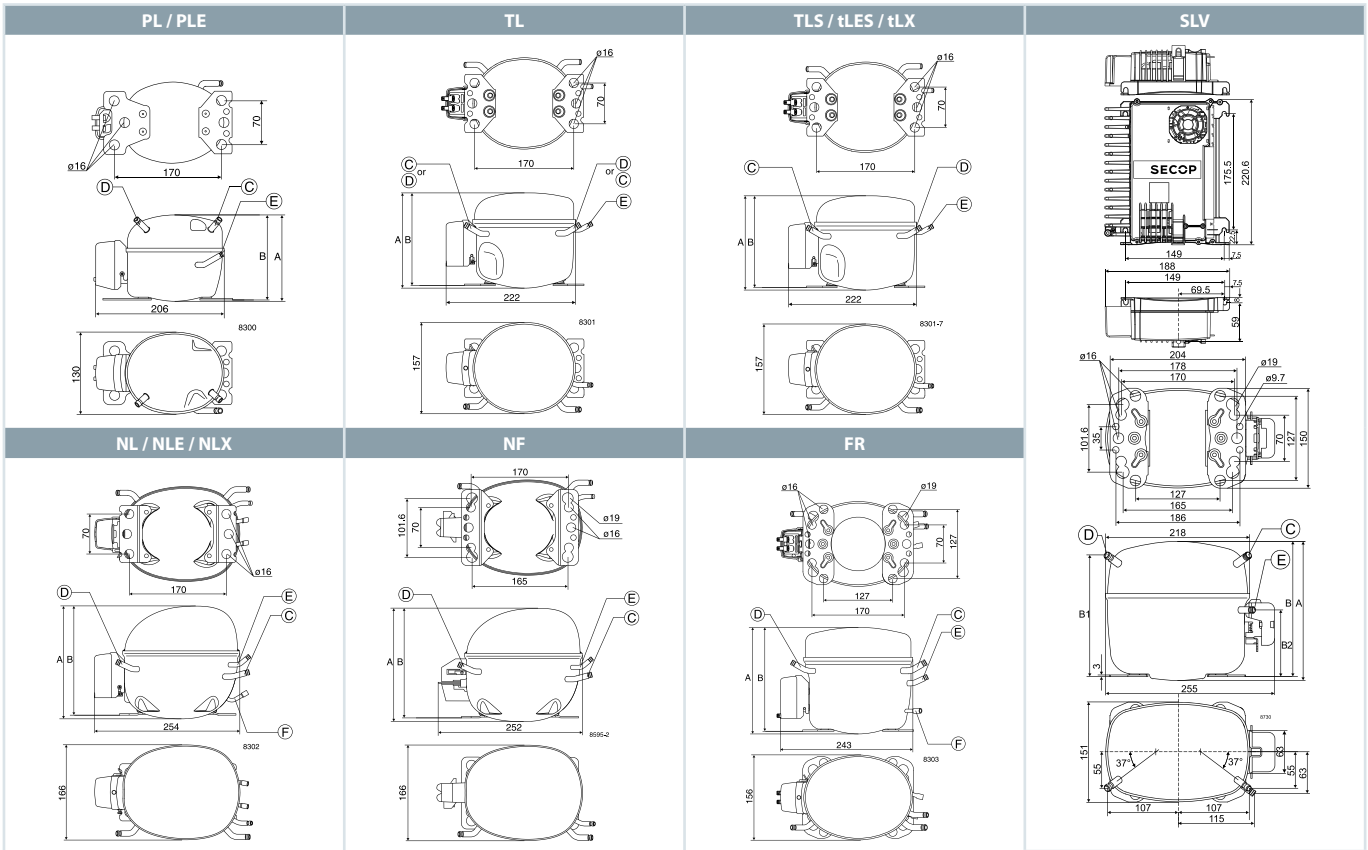

Compressor design	Optimization level	Compressor size	Application range	Start characteristics	Generation
PL	Blank Standard energy level S Semi-direct intake E Energy-optimized	Nominal displacement in cm ³ Exception: For PL compressors the capacity at rating point is stated	CL R404A / R507 LBP	Blank => first generation Blank => universal (principal rule) X = HST characteristics (expansion valve) etc.	Blank => first generation .2 => second generation .3 => third generation etc.
TL			CN R290 LBP (MBP)		
NL			DL R404A / R507 HBP		
FR			FR R134a LBP tropical		
SC			G R134a LBP / MBP/hBP		
GS			GH R134a Heat Pumps		
			GHR R134a Heat Pumps optimized		
			K R600a LBP / (MBP)		
			MF R134a MBP		
			ML R404A / R507 MBP		
Examples					
TL	ES	5.7	FT		.3
NL	E	10	MF		
SC		15	CN	X	.2

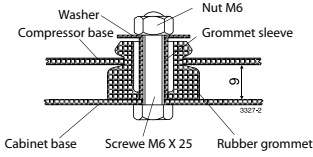

Bolt joint for
one compressor: 118-1917
in quantities: 118-1918

Bolt joint for
one GS compressor: 107B9150 (M8 x 40,
base plate distance: 17 mm)

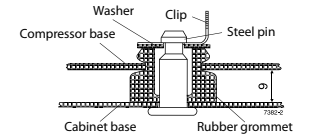

Snap-on
in quantities: 118-1919

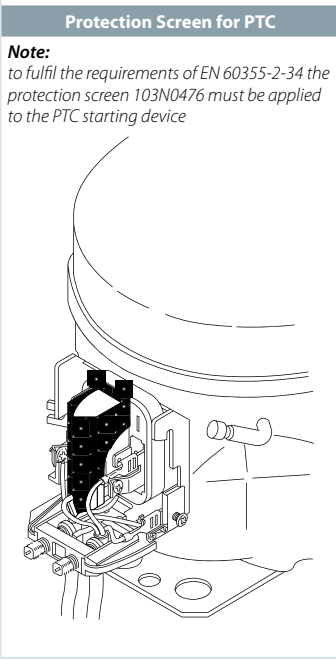
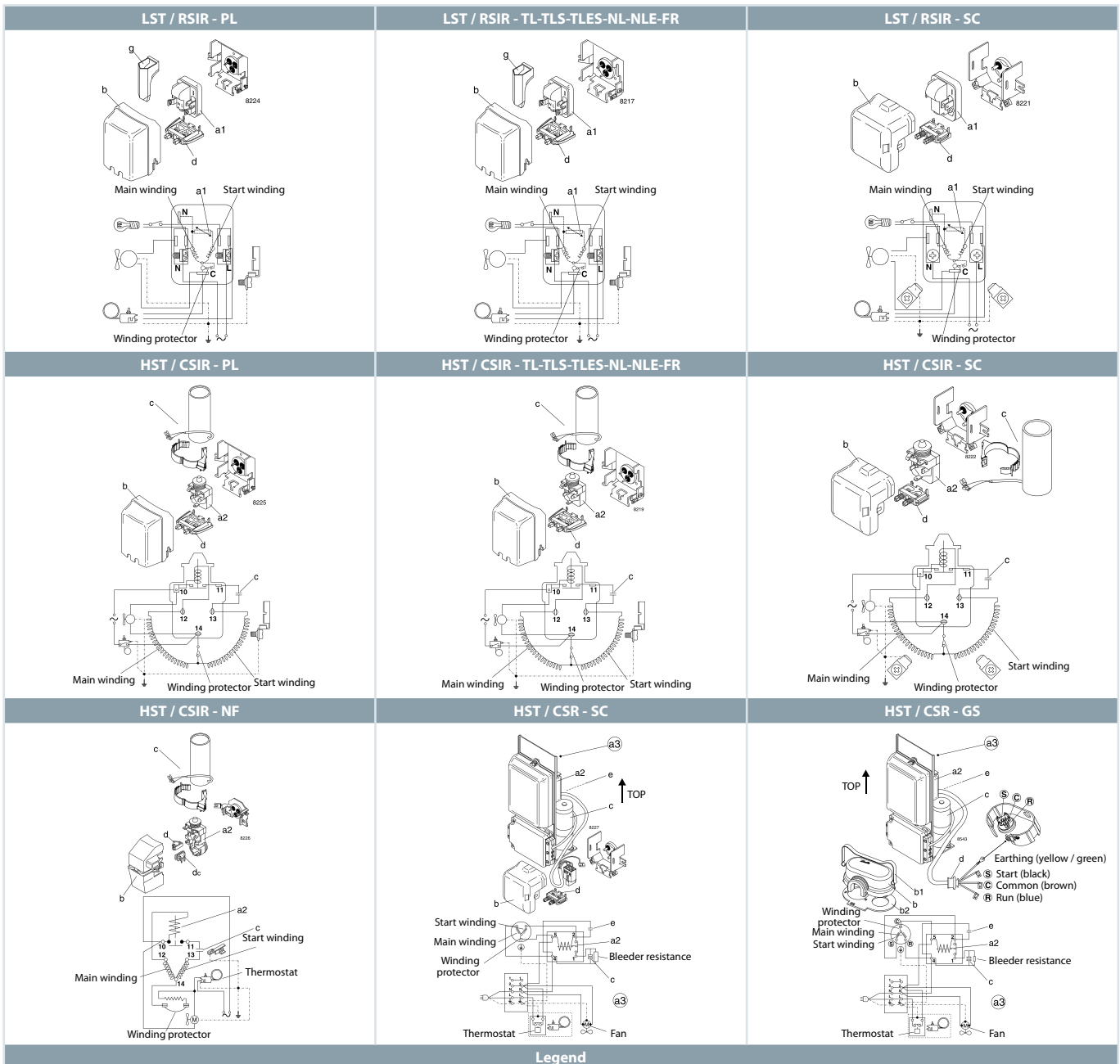

Diagram and dimensions



- a1) PTC starting device
- a2) Starting relay
- a3) Starting device
- b) Cover
- b1) Clamp (part of compressor)
- b2) Gasket (part of compressor)
- c) Starting capacitor
- d) Cord relief
- e) Run capacitor
- g) Protection screen for PTC

01

02

03

04

05

06

07

08

09

10

11

12

13

14

15

MTZ / NTZ Reciprocating compressors

Maneurop® MTZ series compressors are of the hermetic reciprocating type and are designed for medium and high evaporating temperature applications. NTZ are designed for low evaporating temperature applications.

Available in a large variety of single and tandem models for refrigerants R404A, R134a, R407A/F, R407C, R448A, R449A, R452A and R513A*, the compressors fit in lots of different applications.

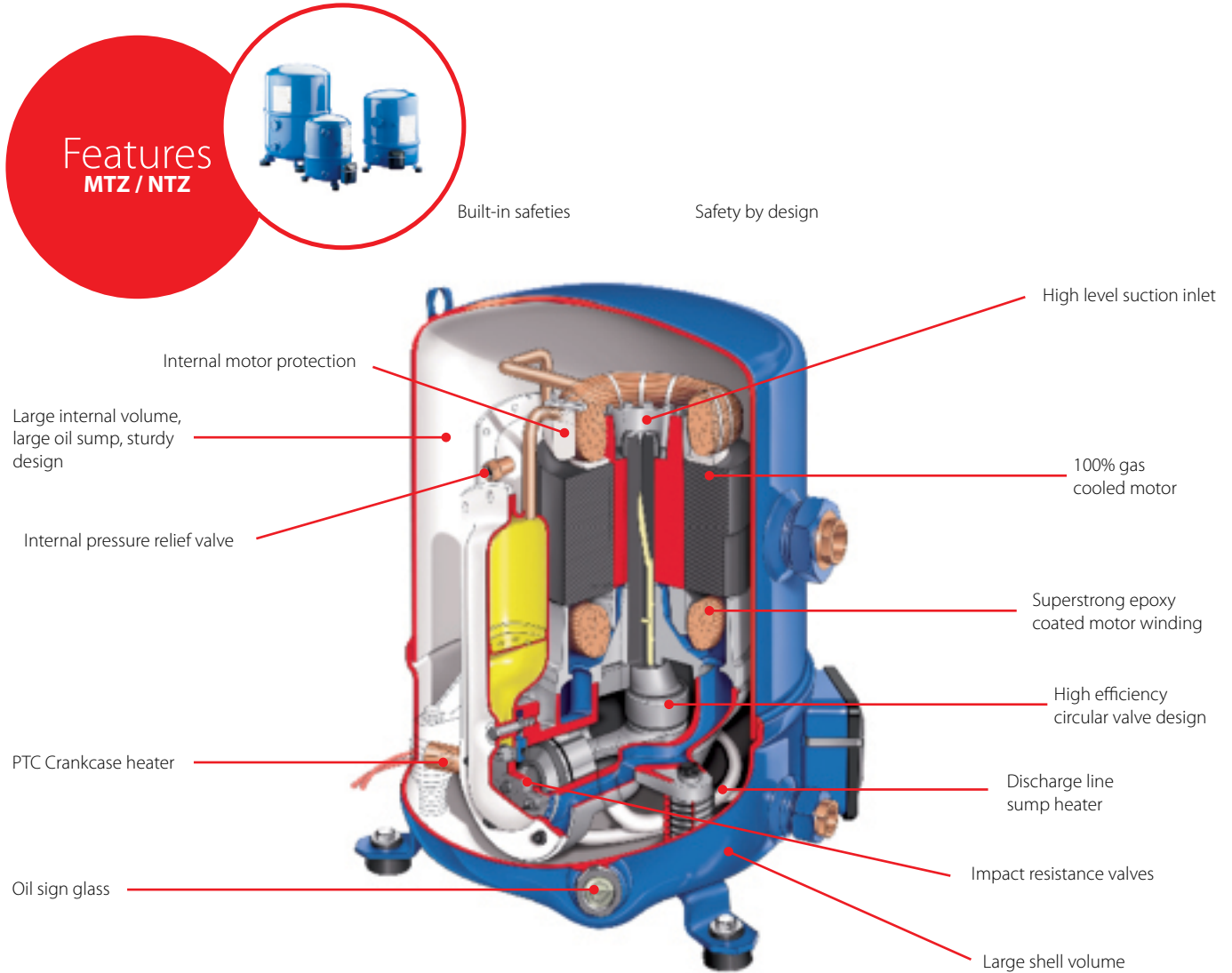

Facts

Applications:

- Walk-in freezers and cold rooms
- Frozen food processing and storage
- Ice cream machines
- Display cabinets
- Water chillers
- Large packaged air conditioners
- Process chillers
- Industrial air-con

Segment usage:

- Airconditioning
- Refrigeration MT (NTZ)

Refrigerants:

- R134a
- R407F
- R407A
- R404A
- R507A
- R407C
- R448A
- R449A
- R452A
- R513A

Capacity range:

- 0.25 – 45 kW

Benefit:

- Operation under extreme conditions
- Versatile
- No need for air circulation around the compressor
- Long lifetime expectancy and reliability

Technical data and ordering

MTZ

Reciprocating compressors

Compressor model	Cooling capacity (W)							Ordering code		No of cylinders	Oil Charge (dm ³)	Displacement (m ³ /h) @2900	Connection			Rotolock valve	
	Refrigeration ¹⁾			High temp ²⁾									Suction	Discharge	Type	Suction	Discharge
	R404A/R507	R134a	R448A/R449A	R513A	R513A	R407C	R134a	400 / 3 / 50 Volts / Phase / Hz	230 / 1 / 50 Volts / Phase / Hz								
MTZ018	2601	1517	2501	1631	2757	3470	2532	MTZ18-4VI	MTZ18-5VI	1	0.95	5.3	1	1	Rotolock	V06	V01
MTZ022	3548	2078	3393	2118	3526	4550	3335	MTZ22-4VI	MTZ22-5VI	1	0.95	6.6	1	1	Rotolock	V06	V01
MTZ028	4592	2491	4189	2652	4426	5890	4217	MTZ28-4VI	MTZ28-5VI	1	0.95	8.4	1	1	Rotolock	V06	V01
MTZ032	5278	2971	4809	3135	5107	6650	4907	MTZ32-4VI	MTZ32-5VI	1	0.95	9.4	1 1/4	1	Rotolock	V09	V06
MTZ036	6123	3688	5587	3612	6010	7510	6013	MTZ36-4VI	MTZ36-5VI	1	0.95	10.5	1 1/4	1	Rotolock	V09	V06
MTZ040	6922	4144	6422	4246	6888	8660	6342	MTZ40-4VI	-	1	0.95	11.8	1 1/4	1	Rotolock	V09	V06
MTZ044	7139	4027	6716	4405	7380	9130	6836	MTZ44-4VI	-	2	1.8	13.3	1 3/4	1 1/4	Rotolock	V07	V04
MTZ050	8330	4647	7657	4889	8085	10420	7956	MTZ50-4VI	-	2	1.8	14.9	1 3/4	1 1/4	Rotolock	V07	V04
MTZ056	8978	4896	8510	5269	8894	11680	8621	MTZ56-4VI	-	2	1.8	16.7	1 3/4	1 1/4	Rotolock	V07	V04
MTZ064	10640	5801	9756	6052	10141	13360	10057	MTZ64-4VI	-	2	1.8	18.7	1 3/4	1 1/4	Rotolock	V07	V04
MTZ072	11820	6678	11230	6839	11436	15320	11543	MTZ72-4VI	-	2	1.8	21	1 3/4	1 1/4	Rotolock	V07	V04
MTZ080	13660	7530	1309	7769	12963	17380	13262	MTZ80-4VI	-	2	1.8	23.6	1 3/4	1 1/4	Rotolock	V02	V04
MTZ100	16210	9095	15120	9464	15950	20480	15452	MTZ100-4VI	-	4	3.9	29.8	1 3/4	1 1/4	Rotolock	V02	V04
MTZ125	20730	11350	20340	12790	21058	26880	18941	MTZ125-4VI	-	4	3.9	37.5	1 3/4	1 1/4	Rotolock	V02	V04
MTZ144	24140	14410	22830	14680	23855	29770	23536	MTZ144-4VI	-	4	3.9	42.1	1 3/4	1 1/4	Rotolock	V02	V04
MTZ160	26480	16200	26180	16570	26641	34090	25779	MTZ160-4VI	-	4	3.9	47.3	1 3/4	1 1/4	Rotolock	V02	V04

1) Refrigeration $T_e = -5^\circ\text{C}$, $T_c = 45^\circ\text{C}$, $SC = 2K$, $SH = 10K$

2) High temp $T_e = 5^\circ\text{C}$, $T_c = 50^\circ\text{C}$, $SC = 0K$, $SH = 10K$

Rotolock connection of compressor can be changed to solder with solder sleeve

(Check the general spare part listing in this catalogue)

Technical data and ordering

MTZ

Code numbers (for ordering)

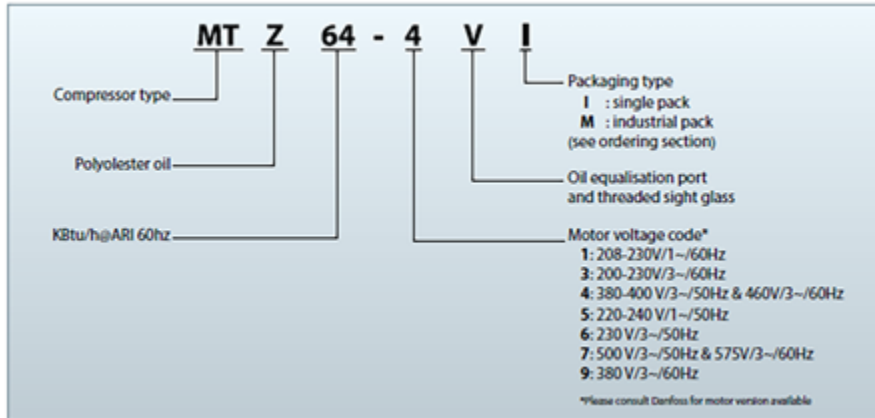

MTZ

Compressor reference

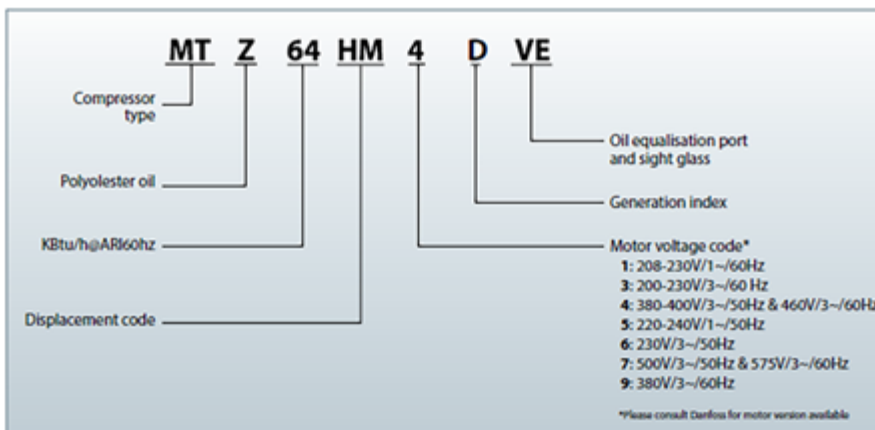

Technical data and ordering

NTZ

Reciprocating compressors

Compressor model	Cooling capacity (W)		Code no.		Oil Charge (dm ³)	No of cylinders	Connection			Rotolock valve	
	Refrigeration ¹⁾		400 / 3 / 50 Volts / Phase / Hz	230 / 1 / 50 Volts / Phase / Hz			Suction	Discharge	Type	Suction	Discharge
	R404A	R452A									
NTZ048	1493	1484	120F0226	120F0228	0.95	1	1 1/8	1	Rotolock	V09	V06
NTZ068	2446	2442	120F0230	120F0232	0.95	1	1 1/8	1	Rotolock	V09	V06
NTZ096	2955	3085	120F0234	–	1.8	2	1 3/4	1 1/4	Rotolock	V07	V04
NTZ108	3583	3761	120F0238	–	1.8	2	1 3/4	1 1/4	Rotolock	V07	V04
NTZ136	4565	4747	120F0236	–	1.8	2	1 3/4	1 1/4	Rotolock	V02	V04
NTZ215	7046	6942	120F0240	–	3.9	4	1 3/4	1 1/4	Rotolock	V02	V04
NTZ271	9701	9150	120F0242	–	3.9	4	1 3/4	1 1/4	Rotolock	V02	V04

1) Refrigeration Te= -25°C, Tc = 45°C, SC = 0K, SH = 10K

Rotolock connection of compressor can be changed to solder with solder sleeve

(Check the general spare part listing in this catalogue)

NTZ

Compressor reference

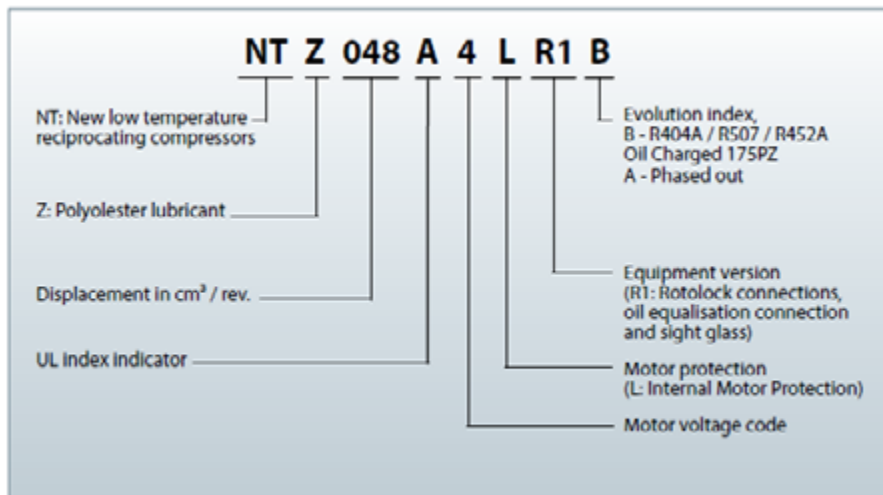

MTZ and NTZ spares ordering



Single Phase PSC starting kits

Code n°	Description	Application	Packaging	Pack size
7701026	Permanent capacitors 440V, 20 µF, 10 µF	MT(Z)18-5, 22-5, 28-5 & NTZ 048-5, 068-5	Multipack	4



Single phase CSR starting kits

Code n°	Description	Application	Packaging	Pack size
7701022	Relay + Capacitors: run (20 + 10 µF), start (98 µF)	MT(Z)18-5, 22-5, 28-5 & NTZ 048-5, 068-5	Multipack	4
7701023	Relay + Capacitors: run (25 + 10 µF), start (140 µF)	MT(Z)32-5, 36-5	Multipack	4



3 phase soft start equipment

Code n°	Description	Application	Packaging	Pack size
7705006	Electronic soft start kit, MCI 15 C	MT(Z)18-81	Single pack	1
7705007	Electronic soft start kit, MCI 25 C	MT(Z)100-160	Single pack	1



Relays and capacitors

Code n°	Description	Application	Packaging	Pack size
8173022	Starting relay type RVA6AMKL	All Single pack phase models (code 1&5)	Single pack	1
8173001	Starting capacitor 330V, 88-108 µF (98 µF)	CSR starting kits	Multipack	10



Acoustic hoods

Code n°	Description	Application	Packaging	Pack size
120Z0575	Slim acoustic hood for 1 cyl	MT(Z)18-40 & NTZ048-068	Single pack	1
120Z0576	Slim acoustic hood for 2 cyl	MT(Z)44-81 & NTZ096-136	Single pack	1
120Z0577	Slim acoustic hood for 2 cyl	MT(Z)100-160 & NTZ215-271	Single pack	1



Mounting kits

Code n°	Description	Application	Packaging	Pack size
8156001	Mounting kit 1 & 2 cyl; Ebox: 80 x 96 mm; Sleeves 5/8" - 1/2"	MT/MTZ18-81 & NTZ048-136	Single pack	1
8156007	Mounting kit for 4 cylinder compressor & MS, including 4 grommets, 4 bolts Ebox; 96 x 115 mm; Sleeves 1"1/8 - 3/4"	MT/MTZ100-160 & NTZ215-271	Single pack	1



Terminal boxes, covers & T-block connectors

Code n°	Description	Application	Packaging	Pack size
8156134	Cover 80 x 96 mm ; clamp	MT/MTZ18-44(1), 18-73(3), 18-81(4), 18-50(5), 18-40(6), 32-56(7), 22-80(9) & NTZ048-136 (EXCEPT 136-1)	Multipack	10
8156135	Service kit for terminal box 96 x 115 mm, including 1 cover, 1 clamp	MT/MTZ50-64(1), 80-160(3), 100-160(4), 44-160(6), 100-160(7), 100-160(9) & NTZ136-1, NTZ215-271	Industry pack	10

MLZ / LLZ - Scroll compressors for refrigeration

MLZ and LLZ scroll compressors are dedicated to commercial and light commercial refrigeration applications with refrigerants R134a, R404A / R507A, R22, R407A. Both brazed and rotolock connections are available for most of the compressors.

MLZ: medium-temperature scroll compressors
R404 / R507A, R407A / F, R134a, R448A, R449A, R452A
LLZ: low-temperature scroll available with economizer line (R404A, R507A, R452A).



High efficiency motor

Optimised pressure ration for refrigeration applications

Optimized scroll design

HOOP overload protection
Rotalock or braze connections

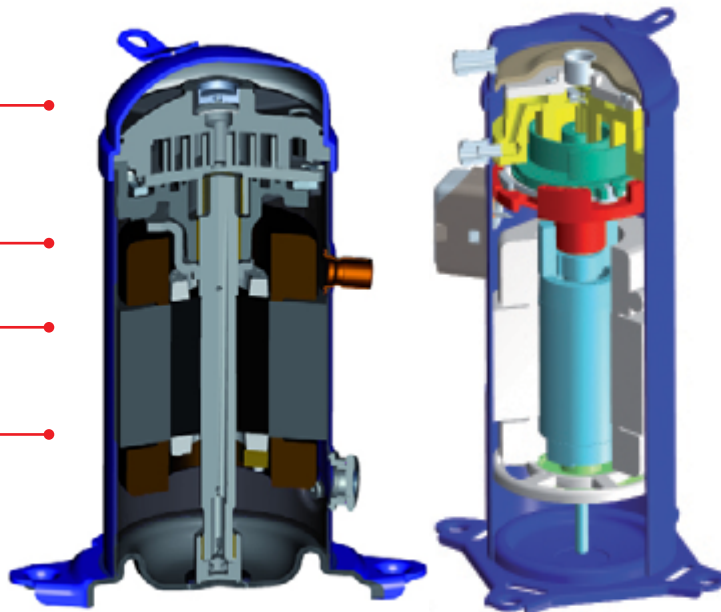

MLZ

LLZ

Optional sound jacket attenuates sound levels

Multi-refrigerant scrolls save on inventory

Suitable for transport of refrigerated goods

Vapor injection available with optional economizer kit increases LLZ efficiency and cooling capacity

Facts

Applications:

- Walk-in freezers and cold rooms
- Frozen food processing and storage
- Blast freezers
- Low temperature racks
- Ice cream machines
- Display cabinets
- Water chillers
- Large packaged air conditioners
- Process chillers etc

Segment usage:

- Refrigeration MT & LT

Refrigerants:

- R404A
- R507A
- R407A/F
- R448A
- R449A
- R452A
- R134A
- R513A

Capacity range:

- 0.5 – 12.5 TR / 1.8 – 44 kW

Benefit:

- Footprint up to 30% smaller than alternative reduces the logistics costs and frees up space in the system
- 30% fewer parts which improves the reliability of the compressor
- Optional vapor injection boosts the cooling capacity and efficiency by more than 20% on LLZ
- Better reliability with improved overload protection and oil injection

Technical data and ordering

MLZ

Scroll compressors

Compressors model	Cooling capacity (W) ¹⁾			Code no.		Connection		
	R404A / R507A	R448A	R134a	400 / 3 / 50 Volts / Phase / Hz	230 / 1 / 50 Volts / Phase / Hz	Suction	Discharge	Type
MLZ015	3931	3978	2540	121L8629	121L8631	3/4	1/2	Brazed
MLZ019	5237	5180	3272	121U8725	121U8729	3/4	1/2	Brazed
MLZ021	5561	5440	3476	121L8633	121L8635	3/4	1/2	Brazed
MLZ026	6863	6778	4298	121L8637	121L8639	3/4	1/2	Brazed
MLZ030	8381	8117	5177	121L8641	121L8643	7/8	1/2	Brazed
MLZ038	9971	9574	6094	121L8645	–	7/8	1/2	Brazed
MLZ045	12160	11920	7551	121L8649	–	7/8	1/2	Brazed
MLZ048	13330	12850	8009	121L8651	–	7/8	3/4	Brazed
MLZ058	15460	15040	9534	121L8653	–	1 1/8	7/8	Brazed
MLZ066	17950	17570	11070	121L8657	–	1 1/8	7/8	Brazed
MLZ076	20280	18970	12340	121L8655	–	1 1/8	7/8	Brazed

1) $T_e = -5^\circ\text{C}$, $T_c = 45^\circ\text{C}$, $RGT = 20^\circ\text{C}$, $SC = 0K$

Stub connection can be converted to rotolock using Solder sleeve adapter sets

(Check listings below)

LLZ

Scroll compressors

Compressors model	Cooling capacity (W) ¹⁾					Code no.	Connection		
	Without economizer / no injection			Liquid injection ²⁾	With economizer / vapour injection		400 / 3 / 50 Volts / Phase / Hz	Suction	Discharge
	R404A	R452A	R448A / R449A	R448A / R449A	R404A				
LLZ013	3536	3295	3053	3053	5662	121L9535	1 1/4	1	Rotolock
LLZ015	4295	3993	3910	3910	6724	121L9537	1 1/4	1	Rotolock
LLZ018	5050	4745	4577	4577	8010	121L9539	1 1/4	1	Rotolock
LLZ024	6451	5876	5549	5549	10060	121L9541	1 3/4	1 1/4	Rotolock
LLZ034	8695	8615	7840	7840	13340	121L9543	1 3/4	1 1/4	Rotolock

1) $T_e = -25^\circ\text{C}$, $T_c = 45^\circ\text{C}$, $SH = 10K$, $SC = 0K$

2) Liquid injection will have same capacity as no injection but will have extended operating envelope.

Rotolock connection of compressor can be changed to solder with solder sleeve

(Check the general spare part listing in this catalogue)

Compressor checkup tips



Technical data and ordering

MLZ

Nomenclature

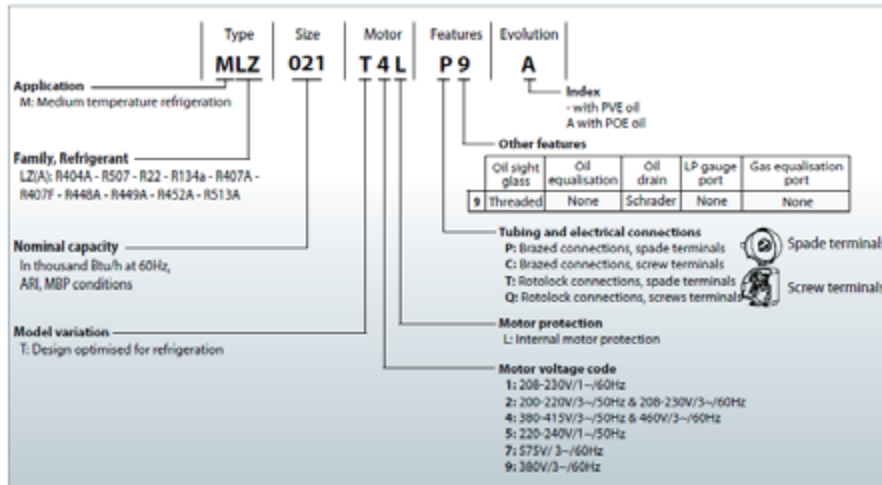

LLZ

Nomenclature

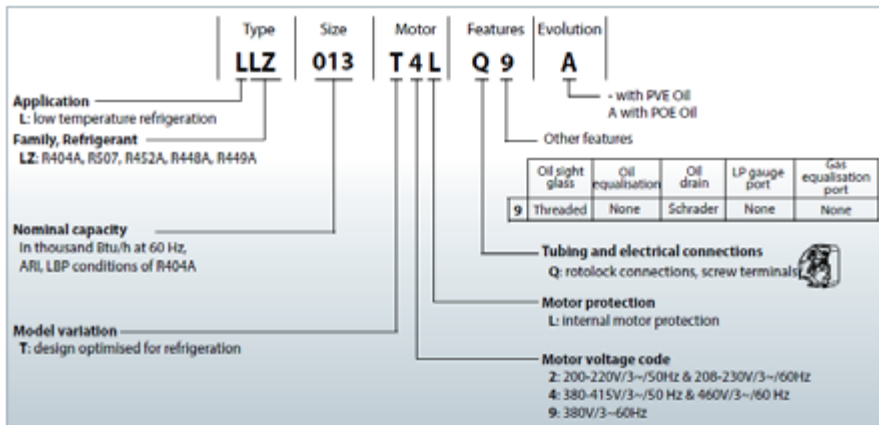

MLZ & LLZ spares

Solder sleeve adapter sets



Code n°	Description	Application	Packaging	Pack size
120Z0126	Solder sleeve adapter set (1" 1/4 Rotolock, 3/4" ODF), (1" Rotolock, 1/2" ODF)	MLZ/MLM015.019.021.026	Multipack	6

Run capacitors for PSC wiring



Code n°	Description	Application	Packaging	Pack size
8173231	Run capacitor 440V, 40 µF	MLZ/MLM015	Multipack	10
120Z0051	Run capacitor 440V, 70 µF	MLZ/MLM019.021.026	Multipack	10
8173234	Run capacitor 440V, 55 µF	MLZ/MLM038.042	Multipack	10

Start capacitors for CSR wiring



Code n°	Description	Application	Packaging	Pack size
120Z0399	Start capacitor 250V, 145-175 µF	MLZ/MLM015.019.021.026	Multipack	10
8173001	Start capacitor 330V, 88-108 µF (98 µF)	MLZ/MLM038.042	Multipack	10

Starting relays for CSR wiring



Code n°	Description	Application	Packaging	Pack size
120Z0393	Starting relay RVA9CKL	MLZ/MLM015.019.021.026	Multipack	10
120Z0394	Starting relay RVA3EKL	MLZ/MLM030	Multipack	10
120Z0395	Starting relay RVA4GKL	MLZ/MLM038.042	Multipack	10

IP54 upgrade kits



Code n°	Description	Application	Packaging	Pack size
118U0056	IP54 upgrade kit for round terminal box	MLZ/MLM015.019.021.026	Multipack	6
118U0057	IP54 upgrade kit for square terminal box	MLZ/MLM030.038.042.045.058.066.076 All LLZ models	Multipack	6

MLZ & LLZ spares



Mounting kits

Code n°	Description	Application	Packaging	Pack size
120Z5064	Mounting kit for 1 scroll compressor including 4 grommets, 4 sleeves, 4 bolts, 4 washers	MLZ/MLM	Single pack	1
120Z0407	Rigid grommets and washes for tandem / rack assembly. Set for 8 compressors	MLZ/MLM	Single pack	1



Terminal box and accessories

Code n°	Description	Application	Packaging	Pack size
120Z5015	Round terminal box (P & T version)	MLZ/MLM015.019.021.026	Multipack	10
120Z5018	Square terminal box (C & Q version)	MLZ/MLM030.038.042.045.058.066.076	Multipack	10



Maifolding service kit

Code n°	Description	Application	Packaging	Pack size
120Z5073	Oil equalisation kit including 2 oil sight glass adaptors, rotolock nuts, sleeves and gaskets, feel spacers and washers for 2 compressors	MLZ/MLM015.019.021.026	Multipack	6

01

02

03

04

05

06

07

08

09

10

11

12

13

14

15

H-Series, Scroll compressor

Danfoss scrolls are designed for excellence in performance, silence and endurance. They feature compressors that are among the quietest, most efficient, reliable and available on the market. Ranging from 2.5 – 10 TR, the universal dimension, footprint and connections of the H series make it the natural choice for greater comfort in existing or new residences.

Available in a large variety of single and tandem models for refrigerants R407C, R134a, R410A and R22, the compressors combine high energy efficiency with low sound and minimal vibration.

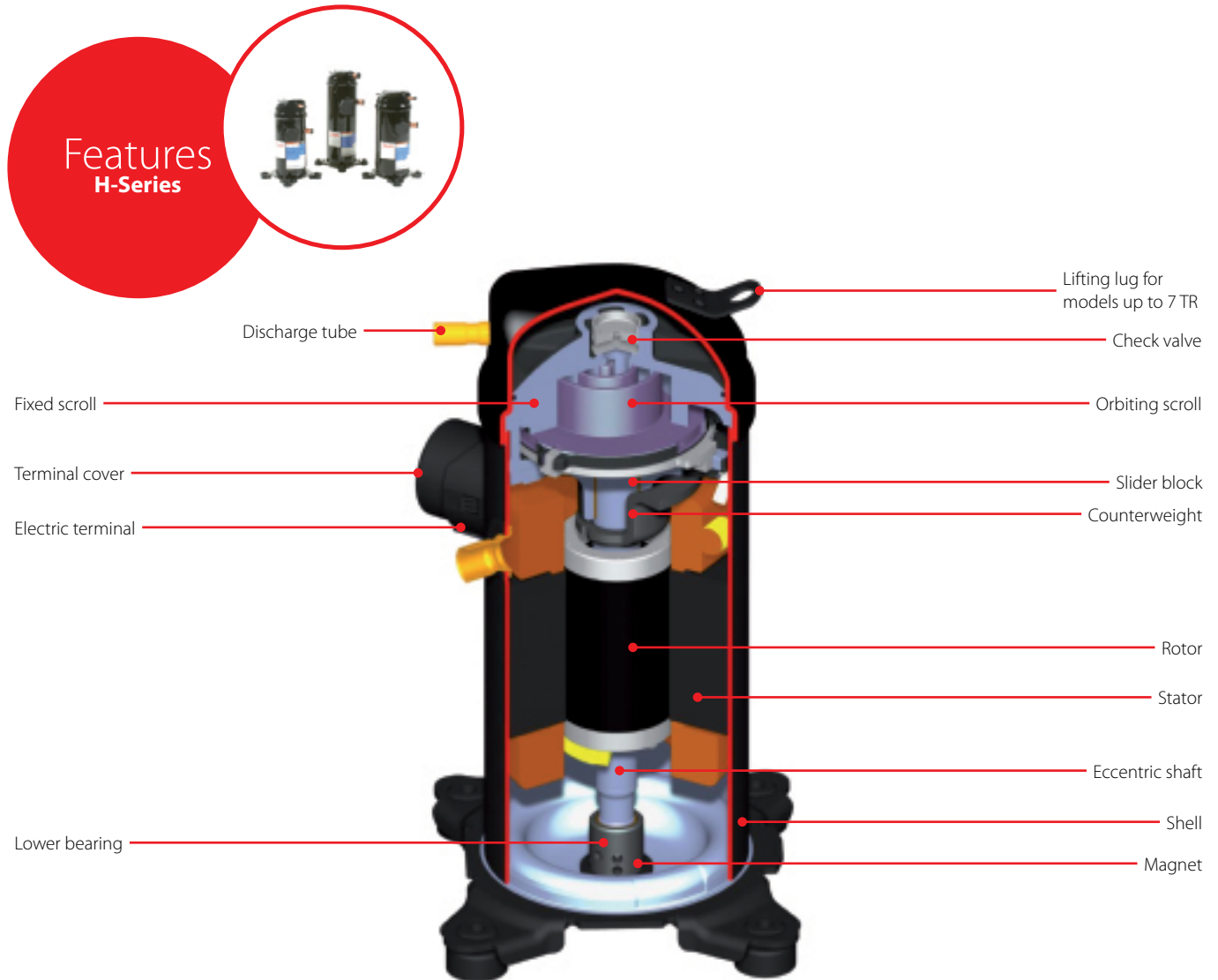

Facts

Applications:

- Small to medium packaged air conditioners for commercial purpose

Segment usage:

- Airconditioning

Refrigerants:

- R134a
- R407C
- R410A
- R22

Capacity range:

- 0.25 – 20 TR / 1.07 – 34 kW

Benefit:

- Excellent reliability due to Patented internal protection combined with HOOP (Hot Oil Over Protector) thermal valve
- Standard dimensions and tubing: ideal for both new installations and replacement markets
- No startup and shutdown noise

Technical data and ordering

H-Series

Scroll compressors

Compressors model	Cooling capacity (W) ¹⁾	Oil Charge (dm ³)	Net weight (kg)	Ordering code		Connection		
	R407C			400 / 3 / 50 Volts / Phase / Hz	230 / 1 / 50 Volts / Phase / Hz	Suction	Discharge	Type
HRP025	5730	1.06	31	121L3088	-	3/4	1/2	Brazed
HRP034	7 940	1.06	31	121L2024	120U2019	3/4	1/2	Brazed
HRP038	8 840	1.06	31	121L1006	-	3/4	1/2	Brazed
HRP040	9 110	1.06	31	121L1016	121L1929	3/4	1/2	Brazed
HRP047	11 130	1.33	31	121L1046	120U0986	3/4	1/2	Brazed
HRP058	13 470	1.57	37	-	120U1596	7/8	1/2	Brazed
HRP060	13 860	1.57	37	121L1726	121L1606	7/8	1/2	Brazed
HLP068	15 700	1.57	37	121L2014	120U1621	7/8	1/2	Brazed
HLP072	16600	1.57	37	121L2072	-	7/8	1/2	Brazed
HLP075	18000	1.57	37	121L1766	-	7/8	1/2	Brazed
HLP081	19500	1.57	37	121L1781	-	7/8	1/2	Brazed
HCP094	21600	2.66	44	121L0601	-	1 1/8	7/8	Brazed
HCP109	26000	2.66	45	121L0376	-	1 1/8	7/8	Brazed
HCP120	28100	2.66	45	121L0401	-	1 1/8	7/8	Brazed

1) Te= 7.2°C, Tc= 54.4 °C, SH= 11.1K, SC= 8.3K

H-Series

Scroll compressors

Compressors model	Cooling capacity (W) ¹⁾	Oil Charge (dm ³)	Net weight (kg)	Code no.		Connection		
	R410A			460 / 3 / 50 Volts / Phase / Hz	230 / 1 / 50 Volts / Phase / Hz	Suction	Discharge	Type
HRH029	7100	1.06	31	121L2287	-	3/4	1/2	Brazed
HRH032	7700	1.06	31	121L1196	121L1171	3/4	1/2	Brazed
HRH036	8800	1.06	31	121L1201	121L1176	3/4	1/2	Brazed
HRH038	9300	1.06	32	-	120U1181	3/4	1/2	Brazed
HRH040	10200	1.33	32	-	121L1186	3/4	1/2	Brazed
HRH041	10000	1.57	37	121L1356	-	7/8	1/2	Brazed
HRH044	10800	1.57	37	121L1361	-	7/8	1/2	Brazed
HRH049	12100	1.57	37	121L1366	-	7/8	1/2	Brazed
HRH051	12900	1.57	37	121L1371	121L1326	7/8	1/2	Brazed
HRH054	13300	1.57	37	-	121L1331	7/8	1/2	Brazed
HRH056	13800	1.57	37	121L1381	-	7/8	1/2	Brazed
HLH061	14800	1.57	37	121L2052 (2)	120U2047	7/8	1/2	Brazed
HLH068	16900	1.57	37	121L1391	121L1341	7/8	1/2	Brazed
HLJ072	17800	1.57	37	121L1396	-	7/8	1/2	Brazed
HLJ083	20400	1.57	37	121L1401	-	7/8	1/2	Brazed

1) Te= 7.2°C (44.96°F), Tc= 54.4 °C / 129.92°F, SH= 11.1K(51.98°F), SC= 8.3K

All compressors have brazed connections, spade terminals

2) Brazed connections, screw terminals

Stub connection can be converted to rotolock using Solder sleeve adapter sets or sol

(Check listings below)

Technical data and ordering

H-Series

Nomenclature

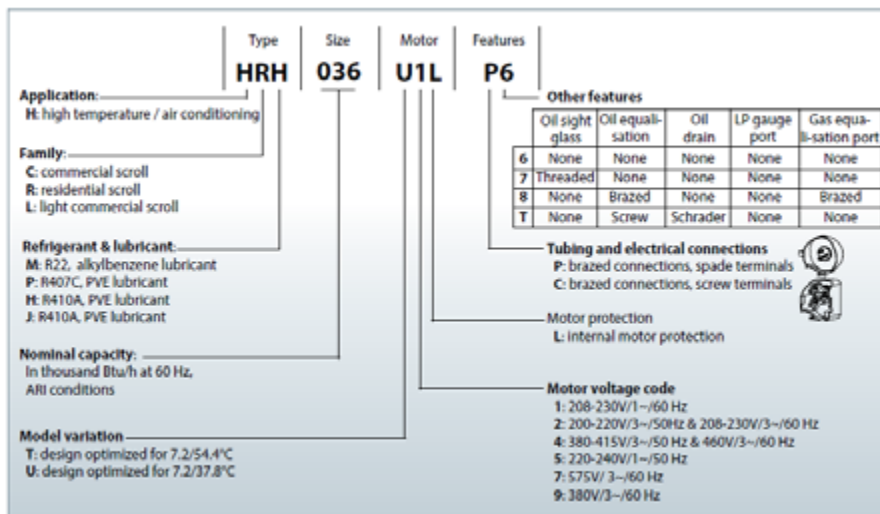

Feature Version T compressors are built with a threaded oil equalization port to be used with Danfoss variable speed compressors range VZH series.

Solder sleeve adapter sets



Code n°	Description	Application	Packaging	Pack size
120Z0126	Solder sleeve adapter set (1" 1/4 Rotolock, 3/4" ODF), (1" Rotolock, 1/2" ODF)	HRM032-042, HRP034-042, HRH029-038, HHP015.019.021.026	Multipack	6

Run capacitors



Code n°	Description	Application	Packaging	Pack size
8173231	Run capacitor 440V, 40 µF	HHP015	Multipack	10
8173234	Run capacitor 440V, 55 µF	HRM054-060, HLM068-081, HRP054-060, HLP068-081, HRH051-056, HLH068, HLJ072-083 all code 5, HHP038	Multipack	10
120Z0050	Run capacitor 440V, 60 µF	HRM045-047, HRP045-047, HRH038-040 all code 5, HHP019-021	Multipack	10
120Z0051	Run capacitor 440V, 70 µF	HRM032-042, HRP034-042, HRH029-036 all code 5, HHP026	Multipack	10

Technical data and ordering



Start capacitors for CSR wiring

Code n°	Description	Application	Packaging	Pack size
120Z0399	Start capacitor 250V, 145-175 µF	HRM032-047, HRP034-047, HRH029-040 all code 5, HHP015.019.021.026	Multipack	10
8173001	Start capacitor 330V, 88-108 µF (98 µF)	HRM058-060, HRP058-060, HLM068-081, HLP068-081, HRH051-056, HLH068, HLJ072-083 all code 5, HHP038	Multipack	10



Starting relays for CSR wiring

Code n°	Description	Application	Packaging	Pack size
120Z0393	Starting relay type RVA9CKL	HRM032-047, HRP034-047, HRH031-040 all code 5, HHP015.019.021.026	Multipack	10
120Z0394	Starting relay type RVA3EKL	HRM051-054, HRP051-054 all code 5, HHP030	Multipack	10
120Z0395	Starting relay type RVA4GKL	HRM058-060, HRP058-060, HLM068-081, HLP068-081, HRH051-056, HLH068, HLJ072-083 all code 5, HHP038	Multipack	10



Mounting kits

Code n°	Description	Application	Packaging	Pack size
120Z5064	Mounting kit for 1 scroll compressor including 4 grommets, 4 sleeves, 4 bolts, 4 washers	HRM, HLM, HCM, HRP, HLP, HCP, HRH, HLH, HLJ, HHP	Single pack	1



IP54 upgrade kit

Code n°	Description	Application	Packaging	Pack size
118U0056	IP54 upgrade kit for round terminal box	HRM, HLM, HCM, HRP, HLP, HCP, HRH, HLH, HLJ, HHP, HHP015.019.021.026	Multipack	6
118U0057	IP54 upgrade kit for square terminal box	HRM, HLM, HCM, HRP, HLP, HCP, HRH, HLH, HLJ, HHP, HHP030.038.045	Multipack	6



Terminal box and accessories

Code n°	Description	Application	Packaging	Pack size
120Z5015	Round terminal box (P & T version)	HRM, HLM, HCM, HRP, HLP, HCP, HRH, HLH, HHP	Multipack	10
120Z5018	Square terminal box (C & Q version)	HRM, HLM, HCM, HRP, HLP, HCP, HRH, HLH, HLJ, HHP	Multipack	10

H series cross referencing

Performer H Series

Danfoss model R407c/R2	HP/R	PH	KW	Bristol	Carlyle	Old Danfoss model R22
HRP034T5LP6	2.8	1	8.1	H20C343ABKA	SCE340AC	HRM032U5LP6
HRP038T5LP6	3.0	1	8.9	H20C373ABKA	SCH370AC	HRM038U5LP6
HRP040T5LP6	3.3	1	9.5	H20C403ABKA	SCE400AC	HRM042U5LP6
HRP045T5LP6	3.5	1	10.7	H20R453ABKA	SRE450AC	HRM045U5LP6
HRP058T5LP6	4.5	1	13.8	H20R583ABKA	SRE580AC	HRM058U5LP6
HRP060T5LP6	5.0	1	14.3	H20R603ABKA	SRE600AC	HRM060U5LP6
HRP068T5LP6	5.7	1	16.0	-	-	HLM068U5LP6
HRP038T4LP6	3.0	3	8.9	H20C373DBEA	SCE370AC	HRM038U4LP6
HRP040T4LP6	3.3	3	9.7	H20C403DBEA	SCH402AC	HRM040U4LP6
HRP045T4LP6	3.5	3	10.9	H20R453DBEA	SRH452AC	HRM045U4LP6
HRP047T4LP6	3.8	3	11.6	H20R483DBEA	SRH482AC	HRM048U4LP6
HRP058T4LP6	4.5	3	14.0	H20R583DBEA	SRH582AC	HRM058U4LP6
HRP060T4LP6	5.0	3	14.5	H20R603DBEA	SRH600AC	HRM060U4LP6
HLP068T4LC6	5.7	3	16.0	-	-	HLM068U4LC6
HLP072T4LC6	6.0	3	17.5	H20R723DBEA	SRH722AE	HLM072T4LC6
HLP075T4LC6	6.5	3	18.4	H20R753DBEA	SRH752AE	HLM075T4LC6
HLP081T4LC6	7.5	3	20.0	H20R813DBEA	SRH812AC	HLM081T4LC6
HCP094T4LC6	8.3	3	23.1	H20R943DBEA	SRH942AE	HCM0943DBEA
HCP109T4LC6	9.0	3	27.0	-	-	-
HCP120T4LC6	10.0	3	29.0	H20R124DBEA	SRH120AE	HCM120T4LC6

Nom ARI Conditions @ +7.2 S.S.T.

Compass

Find the best Danfoss compressor alternative for the existing competitor products



Compressor replacement tips



SH / SM / SY / SZ - S-Series, Scroll compressors

By combining an in-depth understanding of customer needs with continuous investment in product technology Danfoss is able to offer you the S Series, which comprise a 7.5 - 40 TR industry-leading range of high efficiency scroll compressors optimized for rooftop and chiller applications.

Available in a large variety of single and manifold models for R410A, R407C, R134a and R22. The compressors combine high energy efficiency with low sound and minimal vibration.

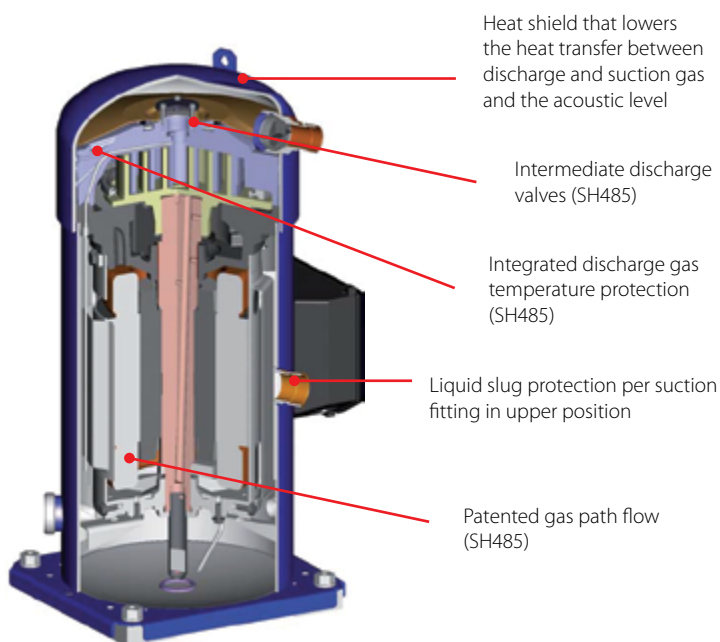
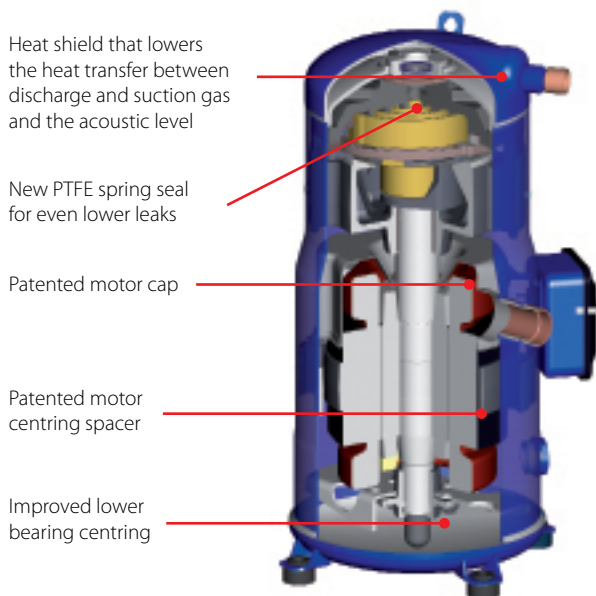

Facts

Applications:

- Rooftop
- Process chiller
- Ducted split air-con
- IT cooling
- Chiller application

Segment usage:

- Airconditioning & High temp.

Refrigerants:

- R134a
- R410A
- R407C

Capacity range:

- 7.5 – 40 TR / 26 – 140 kW

Benefit:

- Greater reliability with the internal non-return valve, which avoids refrigerant migration from the high pressure side
- Highly efficient and reliable protection against overheating, overloading, phase loss and phase order with specific electronic module protection
- Quieter and more efficient operation with "no contact – no wear" scroll design for reduced friction

Technical data and ordering

SH

Scroll compressors

Type	Nominal capacity (W) ¹⁾ R410A	Oil charge (dm ³)	Net weight (kg)	Ordering code	Displacement m ³ /h @ 2900	Connection		
				400 / 3 / 50 Volts / Phase / Hz		Suction	Discharge	Type
SH090	22300	3	58	120H0003	15.404	1 1/8	7/8	Brazed
SH105	26800	3.3	64	120H0211	18.09	1 3/8	7/8	Brazed
SH120	30000	3.3	64	120H0013	20.3	1 3/8	7/8	Brazed
SH140	34700	3.3	67	120H0201	23.1	1 3/8	7/8	Brazed
SH161	38800	3.3	69	120H0023	26.39	1 3/8	7/8	Brazed
SH184	44700	3.6	71.5	120H0361	29.59	1 3/8	7/8	Brazed
SH180	44500	6.7	108	120H0275 ⁴⁾	29.59	1 5/8	1 1/8	Brazed
SH240	59700	6.7	108	120H0291 ³⁾	39.58	1 5/8	1 1/8	Brazed
SH295 ²⁾	73200	6.7	111	120H0827 ⁴⁾	48.11	1 5/8	1 1/8	Brazed
SH300	75140	6.7	153	120H0239 ⁴⁾	49.67	1 5/8	1 1/8	Brazed
SH380	90500	6.7	159	120H0255 ⁴⁾	60	1 5/8	1 1/8	Brazed

1) Te= 7.2°C, Tc= 54.4 °C, SH= 11.1K, SC= 8.3K

2) SH295 replaces SH300. SH300 (120H0239) model remains available for after-market

3) Module 24V AC (Electronic motor protection module located in terminal box)

4) Module 115 - 250V (Electronic motor protection module located in terminal box)

Stub connection can be converted to rotolock using Solder sleeve adapter sets (Check listings below)

SM

Scroll compressors

Type	Nominal capacity (W) ¹⁾ R22	Oil charge (dm ³)	Net weight (kg)	Ordering code	Displacement m ³ /h @ 2900	Connection		
				400 / 3 / 50 Volts / Phase / Hz		Suction	Discharge	Type
SM084	20370	3.25	64	SM084-4VI	19.9	1 1/8	3/4	Brazed
SM090	21790	3.25	65	SM090-4VI	21	1 1/8	3/4	Brazed
SM100	23140	3.25	65	SM100-4VI	22.1	1 1/8	3/4	Brazed
SM110	25940	3.25	73	SM110-4VI	25.1	1 3/8	7/8	Brazed
SM115	28000	3.25	73	SM115-4RI	26.97	1 3/4	1 1/4	Rotolock
SM120	30110	3.25	73	SM120-4VI	29	1 3/8	7/8	Brazed
SM125	30100	3.6	73	SM125-4RI	28.9	1 3/4	1 1/8	Rotolock
SM148	36080	3.6	88	SM148-4VAI	34.6	1 3/8	7/8	Brazed
SM160	39100	3.6	88	SM160-4RAI	37.6	1 5/8	1 1/8	Rotolock
SM161	39020	3.6	88	SM161-4VAI	37.7	1 3/8	7/8	Brazed
SM185	45500	6.2	100	SM185-4CAI	43.5	1 5/8	1 1/8	Brazed
SM185				SM185-4RI		2 1/4	1 3/4	Rotolock

1) Te= 7.2°C, Tc= 54.4 °C, SH= 11.1K, SC= 8.3K

Stub connection can be converted to rotolock using Solder sleeve adapter sets (Check listings below)

Technical data and ordering

SY / SZ

Scroll compressors

Compressors model	Nominal cooling capacity (W) ¹⁾		Oil charge (dm ³)	Net weight (kg)	Code no. 400 / 3 / 50 Volts / Phase / Hz	Displacement m ³ /h @ 2900	Connection		
	R407C	R134a					Suction	Discharge	Type
SZ084	19300	13630	3.25	64	SZ084-4VI	19.9	1 1/8	3/4	Brazed
SZ090	20400	14520	3.25	65	SZ090-4VI	21	1 1/8	3/4	Brazed
SZ100	21600	15500	3.25	65	SZ100-4VI	22.1	1 1/8	3/4	Brazed
SZ110	24600	17550	3.25	73	SZ110-4VI	25.1	1 3/8	7/8	Brazed
SZ120	28600	20260	3.25	73	SZ120-4VI	29	1 3/8	7/8	Brazed
SZ148*	35100	24370	3.6	88	SZ148-4VAI	34.6	1 3/8	7/8	Brazed
SZ161*	38000	26060	3.6	88	SZ161-4VAI	37.7	1 3/8	7/8	Brazed
SZ185*	43100	30440	6.2	100	SZ185-4CAI	43.5	1 5/8	1 1/8	Brazed
	43100	30440	6.2	100	SZ185-4RI	43.5	2 1/4	1 3/4	Rotolock
SY240 ²⁾	59100	40450	8	150	SY240A4PBI ⁴⁾	60.5	2 1/4	1 3/4	Rotolock
	59100	40450	8	150	SY240A4CBI ⁴⁾	60.5	1 5/8	1 1/8	Brazed
SY300 ²⁾	72730	50410	8	157	SY300A4PBI ⁴⁾	76.1	2 1/4	1 3/4	Rotolock
	72730	50410	8	157	SY300A4CBI ⁴⁾	76.1	1 5/8	1 1/8	Brazed
SY380 ²⁾	89540	63260	8.4	158	SY380A4CAI ³⁾	92.4	2 1/8	1 3/8	Brazed
	89540	63260	8.4	158	SY380A4CBI ⁴⁾	92.4			

1) Te= 7.2°C, Tc= 54.4 °C, SH= 11.1K, SC= 8.3K

2) SY240-300-380 has replaced SZ240-300-380 compressors

3) Module 24V AC (Electronic motor protection module located in terminal box)

4) Module 110-240V (Electronic motor protection module located in terminal box)

Stub connection can be converted to rotolock using Solder sleeve adapter sets (Check listings below)

Technical data and ordering

SH

Nomenclature

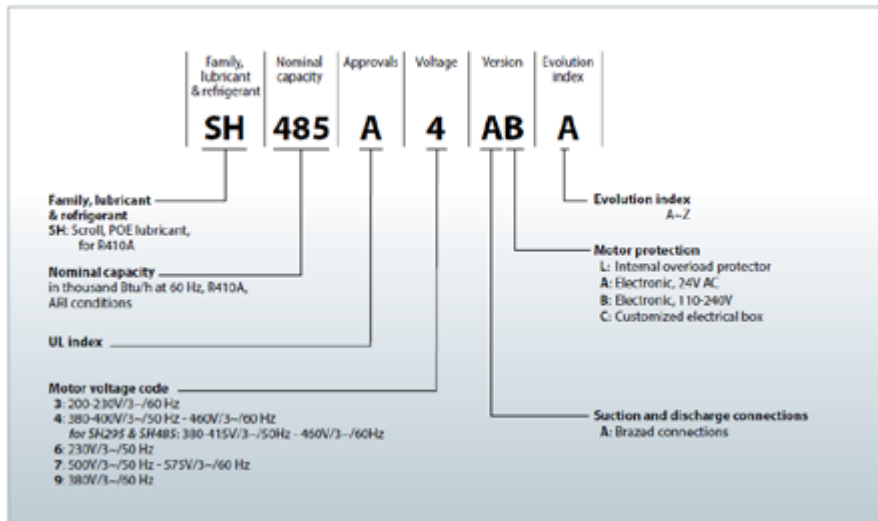

SY / SZ

Nomenclature

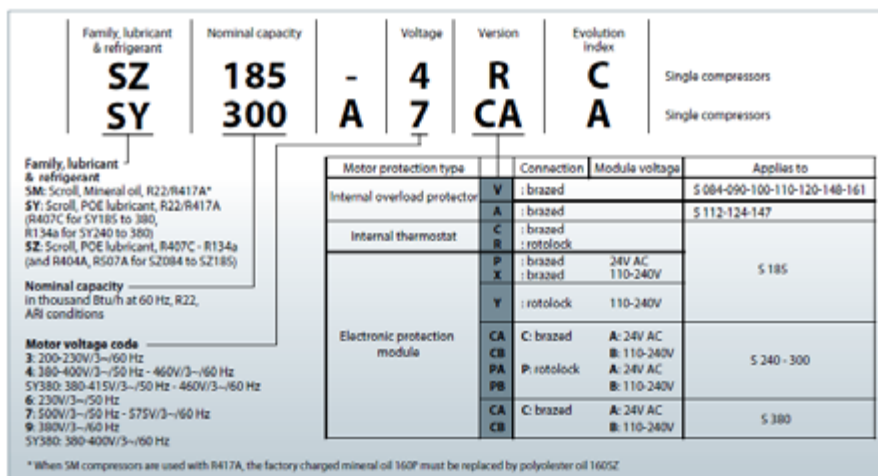

SH / SM / SY / SZ series spares



Solder sleeve adapter sets

Code n°	Description	Application	Packaging	Pack size
7765005	Solder sleeve adapter set (1" 3/4 Rotolock, 1" 1/8 ODF), (1" 1/4 Rotolock, 7/8" ODF)	SM084.090.100 & SZ084.090.100	Multipack	6
7765006*	Solder sleeve adapter set (1" 3/4 Rotolock, 1" 3/8 ODF), (1" 1/4 Rotolock, 7/8" ODF)	SM110.112.120.124.147.148.161 & SZ110.120.148.161 & SH105.120.140.161.184	Multipack	6
7765028	Solder sleeve adapter set (2" 1/4 Rotolock, 1" 5/8 ODF), (1" 3/4 Rotolock, 1" 1/8" ODF)	SM/SY/SZ160.175.185.240.300 & SH180.240.295.300.380 & PSH051.064.077	Multipack	6



3 phase soft start equipment

Code n°	Description	Application	Packaging	Pack size
7705006	Electronic soft start kit, MCI 15C	SM/SZ084-110 & SH090 & WSH090 & PSH019	Single pack	1
7705007	Electric soft start kit, MCI 25 C	SM/SZ115-185 & SH105-184 & WSH105-184 & PSH023.026.030.034.039	Single pack	1
037N0401	Electronic soft start kit, MCI 50 CM	SY/SZ240-380 & SH180-240 to 380 & PSH051.064.077	Single pack	1



Terminal boxes and accessories

Code n°	Description	Application	Packaging	Pack size
8156135	Service kit for terminal box 96 x 115 mm, including 1 cover, 1 clamp	SM084.090.100.110.112.120.124.147.148*.161* SZ084.090.100.110.120.148*.161* SH090.105.120.140*.161* WSH090.105.120.140*.161*	Multipack	10
8156139	Terminal box 186 x 198 mm, incl cover	SMSZ148-3.161-3.175.185	Single pack	1
120Z0458	Terminal box 210 x 190 incl. cover	SH180.240.295.300.380*.485* SY/SZ240.300.380 - SY/SZ185 with module	Single pack	1



Motor protection modules and transformers

Code n°	Description	Application	Packaging	Pack size
120Z0584	Electronic motor protection module, 24V AC	SM/SZ115-185 & SH180	Single pack	1
120Z0585	Electronic motor protection module, 115/240V AC	SY/SZ24-380 & SH240-485	Single pack	1

SH / SM / SY / SZ series spares



Acoustic hoods

Code n°	Description	Application	Packaging	Pack size
7755017	Acoustic hood for scroll compressor	SM/SZ148*.161*	Single pack	1
7755007	Acoustic hood for scroll compressor	SM/SZ175.185	Single pack	1
7755016	Acoustic hood for scroll compressor	SY/SZ240.300	Single pack	1



Mounting kits

Code n°	Description	Application	Packaging	Pack size
8156138	Mounting kit for 1 scroll compressor. Grommets, sleeves, bolts, washers	SM/SZ084-185 (excluding SM112.124.147) & SH180-240 to 485 & PSH051.064.077 in single installation	Single pack	1
120Z066	Mounting kit for 1 scroll compressor. Grommets, sleeves, bolts, washers	SM112-124-147 & SH090-184 & PSH019.023.026.030.034.039	Single pack	1
8156147	Mounting kit for 1 scroll compressor. Grommets, sleeves bolts, washers, rotolock nuts, solder sleeves, gaskets	SM/SZ148-185		
8156007	Mounting kit for 4 cylinder compressor & MS, including 4 grommets, 4 bolts Ebox: 96 x 115mm; Sleeves 1" 1/8 - 3/4"	MS/MSE/MSN115.125.175.185	Single pack	1

DSH / SH Series, Scroll compressors

Danfoss Scrolls SH and DSH are industry leading ranges of high efficiency scrolls optimized for rooftop and chiller applications. They range from 7.5 to 40TR (SH range) and 50 TR (DSH range).

Innovative design of the DSH range bring a new level of compressor robustness and system reliability. They are available in a large variety of single and manifold models for refrigerants R410A, R454B, R452B

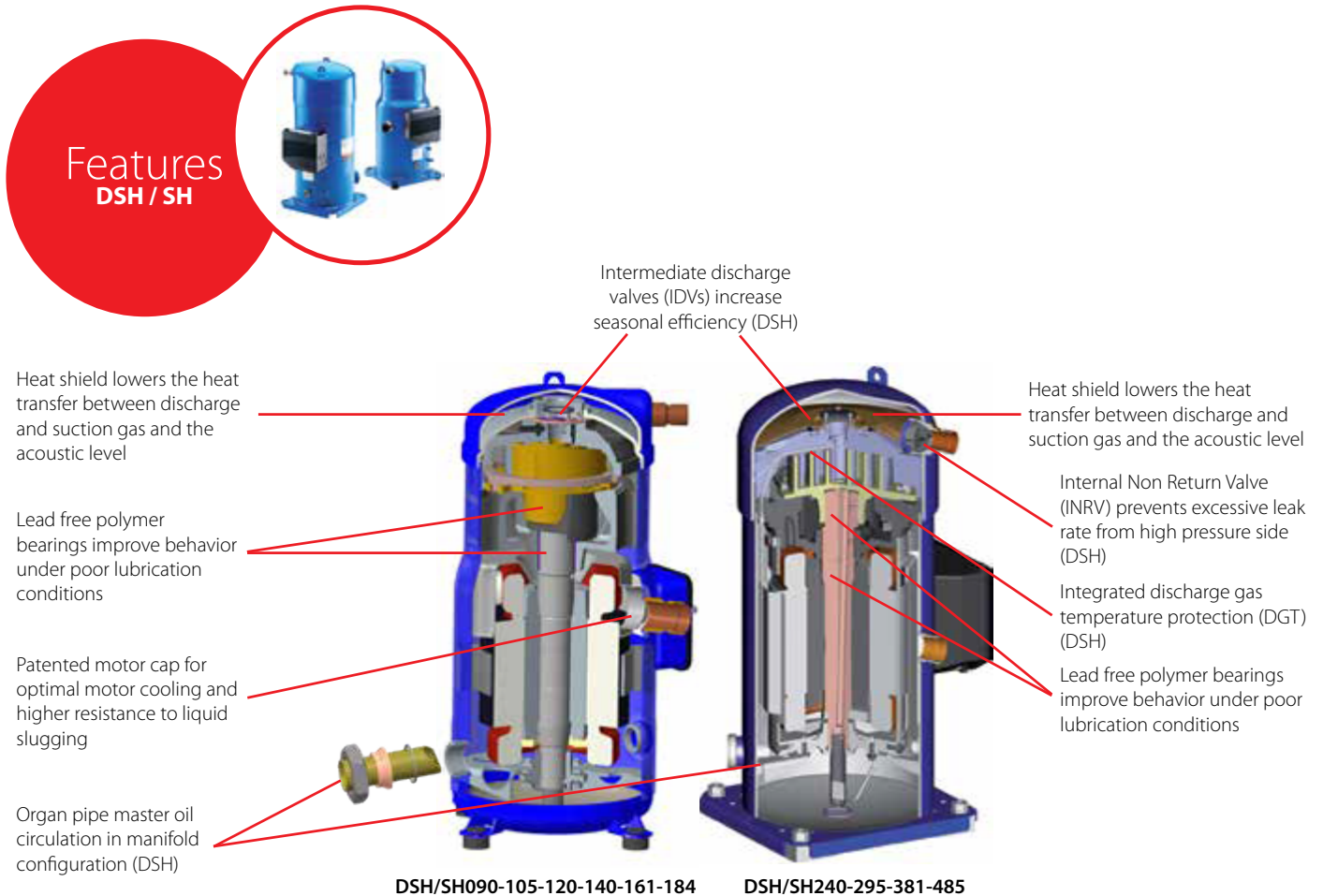

Facts

Applications:

- Rooftop
- Process chiller
- Ducted split air-con
- IT cooling
- Chiller application

Segment usage:

- Airconditioning & High temp.

Refrigerants:

- R410A
- R454B
- R452B

Capacity range:

- 6.2 - 40 TR / 22 - 144 kW

Benefit:

- Greater reliability with the internal non-return valve, which avoids refrigerant migration from the high pressure side
- Intermediate Discharge Valves (IDVs)
 - IDV technology enhances system efficiency by 15% on average in Water-to-Water chillers and by 6% in rooftops and

Air-to-Water chillers

- High efficient and reliable protection against overheating, overloading, phase loss and phase order with specific electronic module protection
- Reduce the load on mechanical parts at start up, provide safe operation at high condensing and evaporating temperatures and contribute to better liquid management

Technical data and ordering

DSH

Scroll compressors

Type	Nominal capacity (W) ¹⁾	Oil charge (dm ³)	Net weight (kg)	Ordering code	Displacement m ³ /h @ 2900	Replaces Old Danfoss compressor	Connection		
				400 / 3 / 50 Volts / Phase / Hz			Suction	Discharge	Type
DSH090	22490	3	58	120H1182	15.4	SH090	1 1/8"	7/8"	Brazed
DSH105	26460	3.3	64	120H1190	18	SH105	1 3/8"	7/8"	Brazed
DSH120	30050	3.3	64	120H1198	20.3	SH120	1 3/8"	7/8"	Brazed
DSH140	34100	3.3	67	120H1206	23.1	SH140	1 3/8"	7/8"	Brazed
DSH161	39130	3.3	69	120H1214	26.4	SH161	1 3/8"	7/8"	Brazed
DSH184	43710	3.6	71.5	120H1222	29.6	SH184	1 3/8"	7/8"	Brazed
DSH240	59050	6.1	114	120H1376 ²⁾	39.6	SH240	1 5/8"	1 1/8"	Brazed
DSH295	72240	6.1	117	120H1370 ³⁾	48.1	SH295	1 5/8"	1 1/8"	Brazed
DSH381	91420	6.1	162	120H1366 ³⁾	60	SH381	1 5/8"	1 1/8"	Brazed
DSH485	117500	6.1	176	120H1362 ³⁾	77	SH485	1 5/8"	1 3/8"	Brazed
DSH600	144500	6.1	215	120H1378 ³⁾	96.2	-	2 1/8"	1 3/8"	Brazed

Note:

1) $T_e = 7.2^\circ\text{C}$, $T_c = 54.4^\circ\text{C}$, $SH = 11.1\text{K}$, $SC = 8.3\text{K}$

2) Module 24V AC (Electronic motor protection module located in terminal box)

3) Module 110 - 240V (Electronic motor protection module located in terminal box)

Please contact Danfoss Team for compressors with other protection modules

DSH

Nomenclature

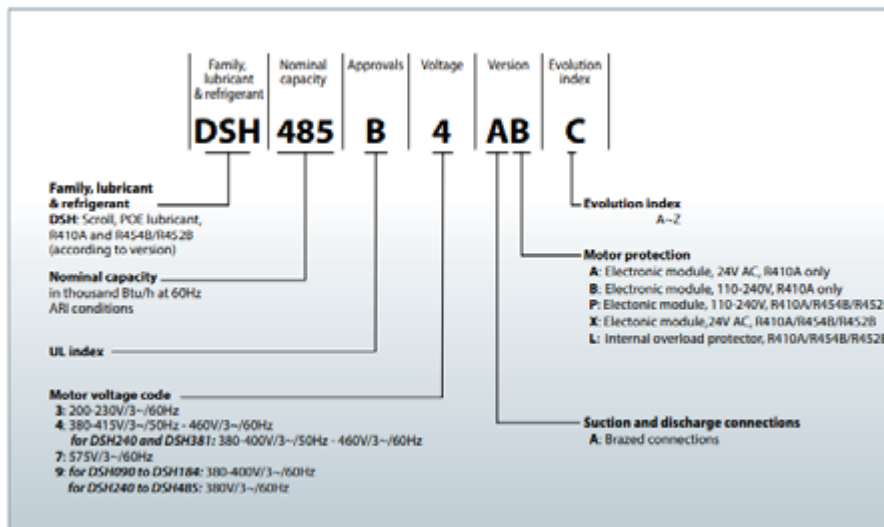

Spare parts and accessories



Lubricants / oils

Code n°	Description	Application	Packaging	Pack size
7754001	Mineral oil, 160P, 2 litre can	SM, MT, MLM116	Multipack	8
7754002	Mineral oil, 160P, 5 litre can	SM, MT, MLM116	Multipack	4
7754019	POE lubricant, 160PZ, 1 litre can	MTZ, NTZ, VTZ	Multipack	12
120Z0573	POE lubricant, 160PZ, 2.5 litre can	MTZ, NTZ, VTZ	Multipack	4
7754023	POE lubricant, 160SZ, 1 litre can	SZ, SH, PSH, WSH, VZH088-117-170, VSH088-177-170	Multipack	12
120Z0571	POE lubricant, 160SZ, 2.5 litre can	SZ, SH, PSH, WSH, VZH088-117-170, VSH088-117-170	Multipack	4
7754121	POE lubricant, 320SZ, 1 litre can	SY	Multipack	12
120Z0572	POE lubricant, 320SZ, 2.5 litre can	SY	Multipack	4
120Z5034	PVE lubricant, 320HV (FVC68D), 1 litre can	HRP, HLP, HCP, HRH, HLH, HLJ, HCJ, HHP, MLZ / MLM / LLZ VZH028-035-044	Single pack	1



Gaskets and gasket sets

Code n°	Description	Application	Packaging	Pack size
8156131	Gasket, G09, 1" 1/4	Models with 1" 1/4 rotolock connection on all models	Multipack	10
8156132	Gasket, G07, 1" 3/4	Models with 1" 3/4 rotolock connection on all models	Multipack	10
8156133	Gasket, G08, 2" 1/4	Models with 2" 1/4 rotolock connection on Danfoss scroll models	Multipack	10
8156009	Gasket set, 1", 1" 1/4, 1" 3/4, OSG gaskets black & white	All 1-2-4 cylinder models	Multipack	10

Crankcase heater



Code n°	Description	Application	Packaging	Pack size
120Z0055	Belt type crankcase heater, 40W, 230V, CE mark, UL	HRM025-047, HRP025-047, HRH029-050 HHP015-019-021-026	Multipack	6
120Z5038	Belt type crankcase heater, 40W, 460V, CE mark, UL	HRM025-047, HRP025-047, HRH029-050 HRM048-060, HLM068-081, HRP048-060, HLP68-081, HRM041-056, HLH061-068, HLJ072-083, HH030-038-045 MLZ/MLM 015-019-021-026	Multipack	6
120Z0057	Belt type crankcase heater, 50W, 230V, CE mark, UL	LLZ all models VZH028-035-044	Multipack	6
120Z0059	Belt type crankcase heater, 65W, 230V, CE mark, UL	HCM094-120, HCP094-120, HCJ090-120, MLZ/MLM030.038.045.058.066.076 LLZ all models	Multipack	6
7773106	Belt type crankcase heater, 54W, 230V, CE mark, UL	All recip 1 cyl	Multipack	4
7773107	Belt type crankcase heater, 65W, 230V, CE mark, UL	SM/SZ084-161, VSH088.117 & VZH288.117,	Multipack	6
7773117	Belt type crankcase heater, 65W, 400V, CE mark, UL	All recip 2 cyl	Multipack	6
120Z0038	Belt type crankcase heater, 65W, 230V, CE mark, UL	VSH088.117 & VZH088.117	Multipack	8
7773110	Belt type crankcase heater, 75W, 110V, CE mark, UL	SM/SZ175-185 & SH180-240 TO 485	Multipack	6
7773108	Belt type crankcase heater, 75W, 230V, CE mark, UL	VSH170 & VZH170	Multipack	6
7773118	Belt type crankcase heater, 75W, 400V, CE mark, UL	All recip 4 cyl	Multipack	6
7773121	Belt type crankcase heater, 130W, 110V, CE mark, UL		Multipack	4
7773122	Belt type crankcase heater, 130W, 230V, CE mark, UL	SY/SZ240-380	Multipack	4
7773123	Belt type crankcase heater, 130W, 400V, CE mark, UL		Multipack	4

Spare parts and accessories



Solder sleeves & Rotolock connector

Code n°	Description	Application	Packaging	Pack size
8153010	Solder sleeve, P01, (1" Rotolock, 3/8" ODF)	Models with 1" rotolock connection	Multipack	10
8153007	Solder sleeve, P06, (1" Rotolock, 1/2" ODF)	Models with 1" rotolock connection	Multipack	10
8153008	Solder sleeve, P04, (1" 1/4 Rotolock, 3/4" ODF)	Models with 1" 1/4 rotolock connection	Multipack	10
8153004	Solder sleeve, P02, (1" 3/4 Rotolock, 1" 1/8 ODF)	Models with 1" 3/4 rotolock connection	Multipack	10
8153006	Solder sleeve, P03, (2" 1/4 Rotolock, 1" 5/8 ODF)	Models with 2" 1/4 rotolock connection	Multipack	10

Rotolock nuts



Code n°	Description	Application	Packaging	Pack size
8153124	Rotolock nut, 1" 3/4	Models with 1" 3/4 rotolock connection	Multipack	10
8153126	Rotolock nut, 2" 1/4	Models with 2" 1/4 rotolock connection	Multipack	10

Rotolock service valves and valve sets (without gasket)



Code n°	Description	Application	Packaging	Pack size
8168027	Rotolock valve, V01, (1" Rotolock, 3/8" ODF)	Models with 1" rotolock connection	Multipack	6
8168031	Rotolock valve, V06, (1" Rotolock, 1/2" ODF)	Models with 1" rotolock connection	Multipack	6
8168029	Rotolock valve, V04, (1" 1/4 Rotolock, 3/4" ODF)	Models with 1" 1/4 rotolock connection	Multipack	6
8168030	Rotolock valve, V05, (1" 1/4 Rotolock, 7/8" ODF)	Models with 1" 1/4 rotolock connection	Multipack	6
8168033	Rotolock valve, V09, (1" 1/4 Rotolock, 5/8" ODF)	Models with 1" 1/4 rotolock connection	Multipack	6
8168028	Rotolock valve, V02, (1" 3/4 Rotolock, 1" 3/8 ODF)	Models with 1" 3/4 rotolock connection	Multipack	6
8168032	Rotolock valve, V07, (1" 3/4 Rotolock, 7/8 ODF)	Models with 1" 3/4 rotolock connection	Multipack	6
8168025	Rotolock valve, V08, (2" 1/4 Rotolock, 1" 3/8 ODF)	Models with 2" 1/4 rotolock connection	Multipack	6

PTC heater



Code n°	Description	Application	Packaging	Pack size
120Z0459	PTC heater 27W	All MTZ/MT/NTZ/VTZ models	Multipack	10

Discharge thermostat kit



Code n°	Description	Application	Packaging	Pack size
7750009	Discharge thermostat kit	All models	Multipack	10

Spare parts and accessories



Surface sump heater

Code n°	Description	Application	Packaging	Pack size
120Z0389	Surface sump heater, 80W, 230V, CE, UL	SM112.124.147 & SH090-184 & WSH090-184 PSH019.023.026.030.034.039 VSH088.117 & VZH088.117	Multipack	8



Miscellaneous

Code n°	Description	Application	Packaging	Pack size
8154001	Danfoss CC blue spray paint	SM, SY, SZ, SH VSH088-117-170 & VZH088-117-170 All models	Single pack	1
8156019	Oil sight glass with gaskets (black & white)	SM, SY, SZ, SH VSH088-117-170 & VZH088-117-170 1-2-4 cylinder VE versions	Multipack	4
8156129	Gasket for oil sight glass (white teflon)	SM, SY, SZ, SH VSH088-117-170 & VZH088-117-170 1-2-4 cylinder VE versions	Multipack	10
8156145	Gasket for oil sight glass (black chloroprene)	Custom products 1-2-4 cyl models produced since 2002	Multipack	10

01

02

03

04

05

06

07

08

09

10

11

12

13

14

15

Optyma™ - Condensing Units

Optyma™ is the widest range of hermetic condensing units on the market. Optyma™ condensing unit is available with reciprocating compressors to cover a large range of commercial refrigeration applications, reducing costs and complexity of the systems. All Optyma™ condensing units are extremely efficient and reliable.

That means less energy consumption and less running costs, less cost for service and maintenance. In addition to the wide Optyma™ range, we also offer local support and guidance if needed.

A network of partner wholesalers and local Danfoss teams can offer you help and will do their outmost to fulfil your needs. At Danfoss we simply believe it is important to offer an "Optimum service".



Pre-mounted LP / HP tubes for easy connection of pressure switch

Easy accessible valves

Optimum airflow due to Danfoss designed fan cowl

Base rails designed for easy installation

Facts

Applications:

- Cold stores and freezer rooms
- Milk cooling
- Beer and wine cellars
- Small food retail and mini markets
- Garage forecourt shops
- Display cabinets
- Ice cream freezers
- Bottle coolers

Segment usage:

- Medium temp and Low temp applications

Refrigerants:

- R134a
- R404A
- R290
- For other refrigerants please contact Danfoss

Capacity range:

- 50 - 20,000W

Benefits:

- 100% factory tested for leakage and fully prewired
- Wide application range
- Powder coated steel parts

- High-efficiency condensers allowing an extended application envelope in high ambient conditions
- Reliable components for longer life and less warranty call out costs
- Base plate designed to allow easy mounting on wall brackets
- Flexible add-on design options including: fan speed control, oil separator, pressure switches or weather proof housing
- Easy access to all components for high serviceability and simplified maintenance
- Compact dimensions and minimum foot print for easy handling, shipping and installation

Technical data and ordering

Opty™ - R290 MBP

Model	Code	Version	Compressor	Electrical code (1)	Tamb [°C]	Cooling capacity Q [kW] (2)							
						Te [°C]							
						-25°C	-20°C	-15°C	-10°C	-5°C	0°C	5°C	10°C
OP-MCNC004	114F1206	A10	NLY45RAB	G	27	0.203	0.254	0.311	0.373	0.439	0.510	0.586	0.666
					32	0.186	0.233	0.286	0.343	0.406	0.474	0.546	0.623
					38	0.166	0.208	0.256	0.309	0.367	0.430	0.498	-
					43	0.149	0.187	0.231	0.280	0.334	0.394	-	-
OP-MCNC006	114F1309	A10	NLY60RAB	G	27	0.274	0.341	0.416	0.500	0.590	0.689	0.794	0.906
					32	0.254	0.315	0.385	0.463	0.549	0.642	0.743	0.852
					38	0.230	0.284	0.347	0.419	0.499	0.586	0.682	-
					43	0.210	0.258	0.316	0.382	0.457	0.540	-	-
OP-MCNC008	114F1412	A10	NLY80RAB	G	27	0.354	0.454	0.566	0.691	0.828	0.977	1.138	1.310
					32	0.328	0.418	0.522	0.639	0.768	0.910	1.063	1.228
					38	0.296	0.376	0.469	0.576	0.696	0.829	0.974	-
					43	0.269	0.341	0.426	0.524	0.636	0.761	-	-
OP-MCNC009	114F1415	A10	NLY90RAB	G	27	0.408	0.518	0.641	0.776	0.924	1.084	1.255	1.437
					32	0.378	0.478	0.592	0.719	0.858	1.009	1.173	1.348
					38	0.342	0.431	0.533	0.649	0.778	0.920	1.075	-
					43	0.312	0.391	0.485	0.592	0.712	0.846	-	-
OP-MCNC011	114F1418	A10	NLY12RAB	G	27	0.474	0.603	0.743	0.894	1.056	1.228	1.409	1.601
					32	0.442	0.561	0.691	0.833	0.986	1.149	1.324	1.508
					38	0.404	0.511	0.630	0.760	0.902	1.056	1.221	-
					43	0.372	0.469	0.578	0.699	0.833	0.978	-	-

Note:

A10 version: HP and LP Mini Pressure switch+ Wired Ebox+ Combo filter drier+ Schrader valve

(1) G- 230V- 1ph- 50Hz

(2) Nominal conditions (EN13215), evaporating temperatures at dew point, superheat 10K, Subcooling 0K

Technical data and ordering

Optyma™ - R404A/R507 MBP

Model	Code	Version	Compressor	Electrical code (1)	Tamb [°C]	Cooling capacity Q [kW] (2)					
						Te [°C]					
						-20°C	-15°C	-10°C	-5°C	0°C	5°C
OP-MCHC006	114X2317	A01	FR6DL	G	27	0.376	0.455	0.552	0.666	0.796	0.941
					32	0.337	0.409	0.499	0.603	0.723	0.856
					38	0.293	0.357	0.435	0.528	0.633	0.751
					43	0.259	0.314	0.383	0.464	0.557	-
OP-MCHC010	114X0404	A01	SC10MLX	G	27	0.620	0.767	0.938	1.132	1.348	1.583
					32	0.560	0.696	0.853	1.031	1.229	1.445
					38	0.487	0.609	0.749	0.908	1.085	1.279
					43	0.426	0.535	0.661	0.804	0.963	1.138
OP-MCHC013	114X0407	A01	SC12MLX	G	27	0.737	0.905	1.098	1.316	1.555	1.813
					32	0.666	0.820	0.997	1.196	1.416	1.653
					38	0.579	0.717	0.875	1.052	1.247	1.458
					43	0.506	0.630	0.771	0.930	1.104	1.294
OP-MCHC015	114X2649	A01	SC15MLX	G	27	0.934	1.148	1.396	1.677	1.991	2.337
					32	0.844	1.043	1.273	1.534	1.826	2.150
					38	0.738	0.916	1.124	1.360	1.625	1.919
					43	0.651	0.811	0.998	1.212	1.453	1.722
OP-MCHC018	114X0702	A01	SC18MLX	G	27	1.073	1.315	1.594	1.909	2.259	2.642
					32	0.970	1.195	1.453	1.745	2.070	2.428
					38	0.848	1.050	1.282	1.545	1.840	2.164
					43	0.748	0.929	1.139	1.377	1.644	1.939
OP-MCHC021	114X2765	A01	GS21MLX	G	27	1.259	1.557	1.898	2.278	2.694	3.141
					32	1.128	1.402	1.715	2.064	2.446	2.859
					38	0.978	1.222	1.500	1.811	2.152	2.523
					43	0.858	1.076	1.325	1.603	1.910	2.244

Note:

A01 version: With receiver, 2 stop valves, brackets and copper pipes for KP

(1) G- 230V- 1ph- 50Hz

(2) Nominal conditions (EN13215), evaporating temperatures at dew point, superheat 10K, Subcooling 0K

Technical data and ordering

Optyma™ - R134a MBP

Model	Code	Version	Compressor	Electrical code (1)	Tamb [°C]	Cooling capacity Q [kW] (2)								
						Te [°C]								
						-30°C	-25°C	-20°C	-15°C	-10°C	-5°C	0°C	5°C	10°C
OP-MCGC003	114X0105	A01	TL3G	G	27	0.050	0.066	0.086	0.110	0.137	0.167	0.200	0.236	0.273
					32	0.045	0.060	0.079	0.101	0.126	0.154	0.184	0.217	0.251
					38	0.038	0.052	0.070	0.090	0.112	0.138	0.165	0.194	0.225
					43	0.032	0.045	0.061	0.080	0.101	0.123	0.148	0.175	0.202
OP-MCGC005	114X0112	A00	TL5G	G	27	0.079	0.102	0.130	0.162	0.198	0.238	0.281	0.328	0.376
					32	0.071	0.094	0.120	0.150	0.184	0.222	0.263	0.306	0.352
					38	0.063	0.084	0.108	0.136	0.168	0.203	0.241	0.281	0.323
					43	0.056	0.076	0.099	0.125	0.155	0.187	0.222	0.260	0.321
OP-MCGC006	114X0200	A00	FR6G	G	27	0.110	0.146	0.188	0.238	0.296	0.364	0.441	0.527	0.623
					32	0.097	0.131	0.172	0.219	0.275	0.340	0.413	0.496	0.588
					38	0.080	0.113	0.152	0.197	0.250	0.311	0.380	0.458	0.544
					43	0.067	0.099	0.136	0.179	0.229	0.287	0.352	0.426	0.508
OP-MCGC007	114X0217	A01	FR7.5G	G	27	0.118	0.156	0.202	0.256	0.319	0.392	0.474	0.567	0.669
					32	0.103	0.140	0.184	0.236	0.296	0.366	0.444	0.532	0.630
					38	0.087	0.122	0.164	0.213	0.269	0.335	0.408	0.491	0.583
					43	0.074	0.108	0.148	0.194	0.248	0.309	0.379	0.457	0.543
OP-MCGC008	114X0225	A01	FR8.5G	G	27	0.139	0.184	0.239	0.302	0.376	0.458	0.551	0.653	0.765
					32	0.129	0.171	0.222	0.281	0.350	0.428	0.516	0.613	0.720
					38	0.112	0.151	0.198	0.253	0.317	0.389	0.472	0.564	0.666
					43	0.097	0.133	0.177	0.229	0.289	0.358	0.436	0.525	0.623
OP-MCGC008	114X0204	A00	NL8.4MF	G	27	-	-	0.269	0.339	0.418	0.508	0.606	0.714	0.828
					32	-	-	0.248	0.314	0.388	0.472	0.565	0.666	0.775
					38	-	-	0.224	0.284	0.353	0.431	0.516	0.610	0.711
					43	-	-	0.205	0.261	0.325	0.397	0.477	0.564	0.659
OP-MCGC010	114X0223	A04	SC10G	G	27	0.163	0.241	0.322	0.406	0.499	0.600	0.715	0.844	-
					32	0.153	0.223	0.296	0.374	0.460	0.557	0.666	0.793	-
					38	0.136	0.198	0.263	0.334	0.414	0.505	0.611	0.734	-
					43	0.121	0.177	0.236	0.302	0.377	0.465	0.568	0.690	-
OP-MCGC012	114X0340	A00	SC12G	G	27	0.213	0.281	0.362	0.457	0.566	0.688	0.824	0.972	1.133
					32	0.185	0.249	0.326	0.416	0.519	0.635	0.764	0.906	1.060
					38	0.153	0.213	0.284	0.368	0.464	0.572	0.694	0.828	0.974
					43	0.129	0.185	0.251	0.329	0.419	0.522	0.637	0.764	-
OP-MCGC015	114X0448	A00	SC15G	G	27	-	0.323	0.427	0.552	0.694	0.854	1.029	1.218	1.418
					32	-	0.294	0.397	0.515	0.650	0.800	0.963	1.138	1.323
					38	-	0.252	0.353	0.466	0.592	0.730	0.879	1.039	1.207
					43	-	0.213	0.312	0.421	0.540	0.669	0.807	0.954	1.109
OP-MCGC018	114X0556	A00	SC18G	G	27	-	0.400	0.515	0.649	0.803	0.978	1.173	1.389	1.624
					32	-	0.351	0.465	0.596	0.746	0.915	1.104	1.310	1.532
					38	-	0.307	0.417	0.543	0.685	0.844	1.019	1.211	1.415
					43	-	0.280	0.384	0.502	0.635	0.783	0.946	1.122	-
OP-MCGC021	114X0564	A00	SC21G	G	27	-	0.463	0.601	0.758	0.933	1.125	1.331	1.551	1.783
					32	-	0.421	0.550	0.698	0.862	1.042	1.235	1.441	1.658
					38	-	0.375	0.491	0.624	0.773	0.936	1.112	1.300	1.499
					43	-	0.337	0.440	0.559	0.694	0.842	1.003	1.176	1.359
OP-MCGC026	114X0773	A01	GS26MFX	G	27	-	-	0.873	1.125	1.416	1.745	2.113	2.519	-
					32	-	-	0.809	1.045	1.317	1.625	1.970	2.350	-
					38	-	-	0.736	0.953	1.202	1.485	1.801	2.151	-
					43	-	-	0.675	0.877	1.108	1.369	1.662	1.986	-
OP-MCGC034	114X0781	A01	GS34MFX	G	27	-	-	1.138	1.432	1.772	2.158	2.592	3.072	-
					32	-	-	1.051	1.330	1.652	2.018	2.429	2.886	-
					38	-	-	0.946	1.207	1.507	1.848	2.232	2.660	-
					43	-	-	0.858	1.103	1.385	1.706	2.067	2.470	-

Note:

A00: Without valves and receiver for capillary tubes

A01: With receiver, 2 stop valves, brackets and copper pipes for KP

A04: A01 + KP17 WB + FSA-kit + power cord

(1) G- 230V- 1ph- 50Hz

(2) Nominal conditions (EN13215), evaporating temperatures at dew point, superheat 10K, Subcooling 0K

Technical data and ordering

Optyma™ - R290 LBP

Model	Code	Version	Compressor	Electrical code (1)	Tamb [°C]	Cooling capacity Q [kW] (2)						
						Te [°C]						
						-40°C	-35°C	-30°C	-25°C	-20°C	-15°C	-10°C
OP-LCNC004	114F0203	A10	NLY45LAb	G	27	0.095	0.128	0.166	0.209	0.256	0.307	0.363
					32	0.086	0.116	0.152	0.192	0.236	0.284	0.337
					38	0.075	0.103	0.134	0.171	0.212	0.257	0.307
					43	0.067	0.091	0.120	0.154	0.192	0.235	0.282
OP-LCNC006	114F0206	A10	NLY60LAb	G	27	0.120	0.163	0.211	0.265	0.323	0.386	0.453
					32	0.110	0.148	0.193	0.242	0.296	0.356	0.419
					38	0.097	0.131	0.170	0.215	0.265	0.320	0.379
					43	0.087	0.116	0.152	0.193	0.239	0.290	0.346
OP-LCNC008	114F0309	A10	NLY80LAb	G	27	0.162	0.219	0.284	0.356	0.436	0.523	0.616
					32	0.148	0.199	0.258	0.325	0.400	0.482	0.571
					38	0.131	0.175	0.228	0.289	0.357	0.433	0.517
					43	0.117	0.156	0.203	0.259	0.322	0.393	0.472
OP-LCNC011	114F0412	A10	NPY12LAb	G	27	0.258	0.342	0.440	0.550	0.671	0.805	0.950
					32	0.235	0.312	0.402	0.505	0.619	0.746	0.884
					38	0.208	0.276	0.357	0.451	0.557	0.675	0.805
					43	0.185	0.246	0.320	0.406	0.505	0.616	0.740

Note:

A10 version: HP and LP Mini Pressure switch+ Wired Ebox+ Combo filter drier+ Schrader valve

(1) G- 230V- 1ph- 50Hz

(2) Nominal conditions (EN13215), evaporating temperatures at dew point, superheat 10K, Subcooling 0K

Technical data and ordering

Optyma™ - R404A/R507 LBP

Model	Code	Version	Compressor	Electrical code (1)	Tamb [°C]	Cooling capacity Q [kW] (2)							
						Te [°C]							
						-45°C	-40°C	-35°C	-30°C	-25°C	-20°C	-15°C	-10°C
OP-LCHC008	114X1301	A01	NL8.4CLX	G	27	0.121	0.169	0.227	0.293	0.369	0.452	0.543	0.640
					32	0.121	0.153	0.204	0.265	0.333	0.408	0.491	0.579
					38	0.094	0.131	0.176	0.229	0.288	0.354	0.427	0.504
					43	0.079	0.112	0.151	0.197	0.249	0.308	0.372	0.441
OP-LCHC012	114X1441	A01	SC12CLX	G	27	-	0.243	0.333	0.439	0.563	0.704	0.862	1.037
					32	-	0.198	0.282	0.381	0.496	0.626	0.773	0.936
					38	-	0.146	0.221	0.311	0.414	0.533	0.666	0.814
					43	-	-	0.172	0.253	0.347	0.454	0.576	0.711
OP-LCHC015	114X1549	A01	SC15CL	G	27	-	0.285	0.389	0.507	0.639	0.788	0.951	1.130
					32	-	0.233	0.335	0.449	0.576	0.716	0.870	1.038
					38	-	-	-	0.375	0.496	0.627	0.771	0.926
					43	-	-	0.151	0.311	0.426	0.551	0.686	0.832
OP-LCHC018	114X1557	A01	SC18CLX	G	27	0.260	0.362	0.486	0.632	0.801	0.991	1.203	1.435
					32	0.215	0.310	0.423	0.557	0.712	0.886	1.082	1.296
					38	-	0.250	0.351	0.470	0.608	0.764	0.939	1.132
					43	-	-	0.294	0.400	0.524	0.664	0.822	0.998

Note:

A01 version: With receiver, 2 stop valves, brackets and copper pipes for KP

(1) G- 230V- 1ph- 50Hz

(2) Nominal conditions (EN13215), evaporating temperatures at dew point, superheat 10K, Subcooling 0K

One Supplier Covers your Industrial Refrigeration Needs

Danfoss has made a clear priority to be able to supply all types of components for industrial refrigeration. Having just one place to go for industrial refrigeration is a significant benefit. Danfoss' one-stop-shop concept makes constructing as well as servicing fast and easy and helps keep the part stock at a minimum.

Whether your industrial refrigeration plant is a manual system or a highly-automated system, you will be sure to find a Danfoss solution that exactly matches your project needs in our wide range for industrial refrigeration. With the support of our online tools and our dedicated, local staff, we continuously strive to make your selection of solutions safe and easy.

The Flexline™ platform

The Flexline™ platform is synonymous with flexibility within industrial refrigeration. Based on a modular design concept, you will

experience that each product features a variety of benefits, including easy selection, installation and maintenance.

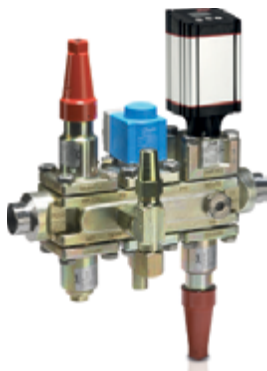

ICF Flexline™ valve station

The Danfoss ICF Flexline™ multi-ported control solution offers you significant savings by substituting a string of valves with just one valve station. Consisting of a valve housing and a maximum of four or six function modules, the valve station is a true plug-and-play solution.



ICFD Defrost Module

The liquid drain method is widely acknowledged as the most efficient hot gas defrost method within industrial refrigeration. The method ensures that liquid condensate is drained at lowest possible pressure resulting in a reduction of blow-by gas by up to 90%.



SLV Flexline™ product platform

The SVL Flexline™ product platform is targeted to meet industrial refrigeration requirements worldwide. Using just two basic valve housings – a straightway and an angleway – the platform offers five different functions.

ICV Flexline™ valves

The ICV product family consists of an ICS pilot operated control, ICM motor operated control and ICLX 2-step solenoid valve. All valve variants are based on one common valve body to offer outstanding flexibility.

The modular concept greatly facilitates the building of a valve that offers energy savings and reduction of down-time. All valves are designed for a maximum working pressure of 52 bar (754 psi) and efficiently handle CO₂ and other future high pressure refrigerants.



ICLX 2-step solenoid valve

The ICLX valves are 2-step servo-operated main valves with pilot solenoid valves offering safe, flexible and convenient installation, operation and service.



ICM motor operated valve

The ICM motor operated valves are very compact and easy to handle. The ICM motor valve is available as a complete valve and as parts programme.



ICS pilot operated servo valve

The ICS pilot operated servo valves are quick and simple to handle, install and service due to their low weight and compact design.



ICSH, dual position solenoid valve

The ICSH dual position solenoid valve is designed for gradual and safe opening of the hot gas flow to the evaporator, featuring an extra-safety-configuration to prevent hydraulic shocks in the system.



New Danfoss Pilot Valve program for ICS control valves

The new Danfoss Pilot Valve program for ICS control valves consist of just 4 fully backwards-compatible valves, which cover all regulation types and ranges needed in ammonia and CO₂ applications.

Danfoss gas detection units for industrial refrigeration systems

The new Danfoss gas detectors are based on an intelligent platform and intuitive user-interface, Danfoss' complete line of fixed gas detectors range from basic to heavy duty models with sensor technology to match the specific refrigerant, application, and safety requirements of your system.

The Danfoss gas detection portfolio enables you to comply with regulations according to EN 378:2016, ISO 5149:2014, IIR 2-2017, and ASHRAE 15:2016 while providing comprehensive safety and easy-to-use features



Evaporator control solution

The evaporator sub-system solution brings together Danfoss' efficient and reliable valves and controls to provide efficient and safe installation, operation & maintenance of the evaporator sub-system.

The evaporator control solution is prepared for smart defrosting which provide an optimized hot gas defrost process to better schedule, control, start and terminate

defrosting delivering improved energy efficiency and reduced defrost cycle duration time. The system features a controller dedicated for industrial refrigeration requirements and applications which manages the steps in the defrost cycle. The solution offers a safe defrost process that meets latest IIR standards for hot gas defrost.



Air purger

The Danfoss Intelligent Purger System is a new, stand-alone air purger solution for multi purging. The automatic purging function, responds immediately to non-condensable gases in the refrigeration system improving system efficiency and safety. With a compact, plug & play design it provides fast and easy installation, saves space and reduces overall cost.

Semi-welded plate heat exchanger

Danfoss semi-welded plate heat exchangers are optimized for Ammonia industrial applications systems such as Condensers, flooded and pumped evaporators, Sub-coolers, Desuperheaters, Superheaters, Economizers and Oil coolers.



Coming Soon

Complete industrial refrigeration solutions supplier for sensor, liquid level regulating valves, safety valves, and switches.



AKS 4100 Liquid Level Sensor

Liquid Level Sensor with TDR Guided Radar technology fully adapted to the Industrial Refrigeration segment – reliable and with high accuracy.



Liquid Level Control (AKS 38, HFI, SV, LLG)

The Danfoss LLS 4000 Electronic Liquid Level Switch is a compact, cost-efficient, and reliable switch for liquid level measurements. With simple, one-point installation, smart commissioning via Bluetooth, and next-level reliability thanks to its SIL2 compliance, the LLS 4000 makes electronic liquid measuring smarter and more reliable than ever.

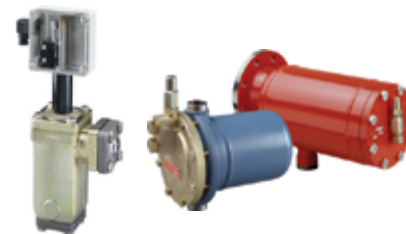

Liquid Level Control (AKS 38, HFI, SV, LLG)

Liquid level control is an important element in the designing of industrial refrigeration systems. It controls the liquid injection to maintain a constant liquid level. Danfoss offers Mechanical and electro-mechanical solution suited for meet varying plant requirements.



Safety Relief Valves (SFA, SFV, DSV, BSV, POV)

Danfoss Safety valves are designed to meet the strict quality demands and safety requirements for refrigeration installations, specified by the international classification societies.



Switches and thermostats for Industrial Refrigeration

Pressure controls and thermostats applicable for industrial refrigeration applications including ammonia as a refrigerant.



Liquid Level Glasses

LLG are liquid level glasses in ductile steel which meets the strictest requirements on industrial and marine refrigeration installations

IR product information



IR products overview



IR tools

If you need any further information, please email to customercare.pac@danfoss.com

Danfoss Infogram

Danfoss has created various of information graphics for you to visualise quickly on how to troubleshoot problems, tips and tricks for selecting and installing products, working principal of products etc.



Danfoss Learning Cooling Catalog

Explore Cooling eLessons based on topics



Solenoid Valves Troubleshooting

Troubleshooting, tips and tricks



360° Solenoid Valve

Selection and installation tips etc



Compressor Replacement

What to remember when selecting a replacement compressor



Thermostatic Expansion Valves Troubleshooting

TXV troubleshooting, tips and tricks



Pressure Regulators

KV valves working principle



TXV Troubleshooting

Expansion troubleshooting, tips and tricks



AKV Electronic Expansion Valves Troubleshooting

Tips and tricks on pulse valve



Condensing Units Selection

Cold room overview



Filter Driers and Sight Glasses

Selection, troubleshooting, symptoms of filter driers and sight glasses





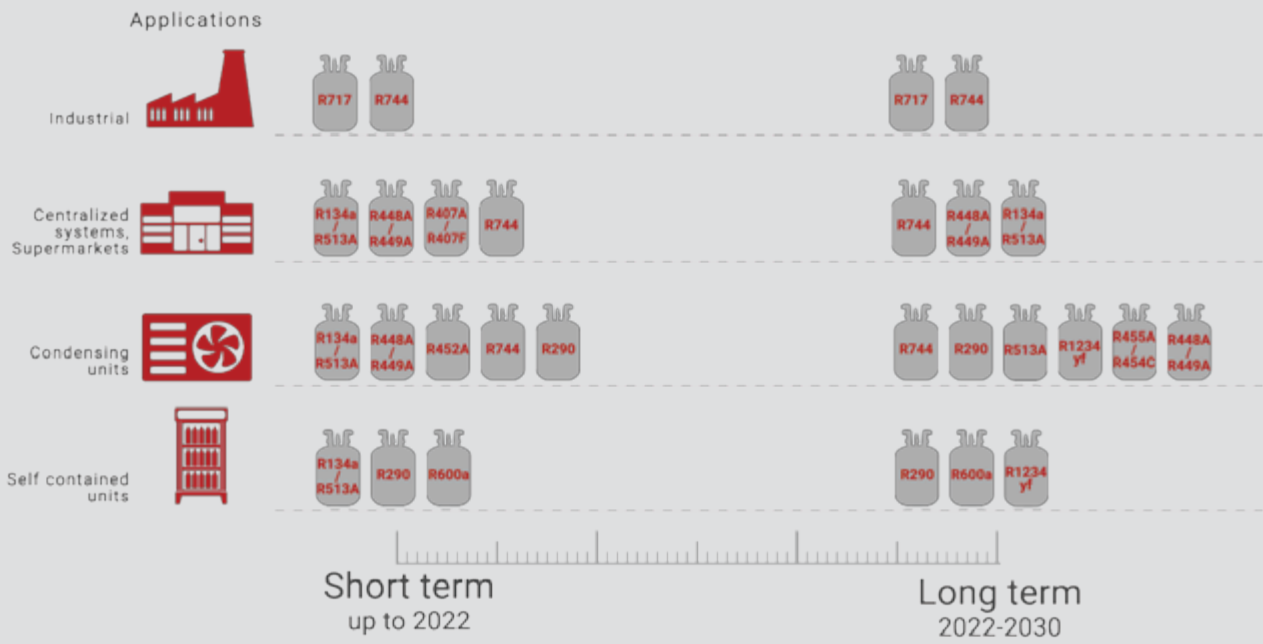

Refrigerant Solutions for Refrigeration

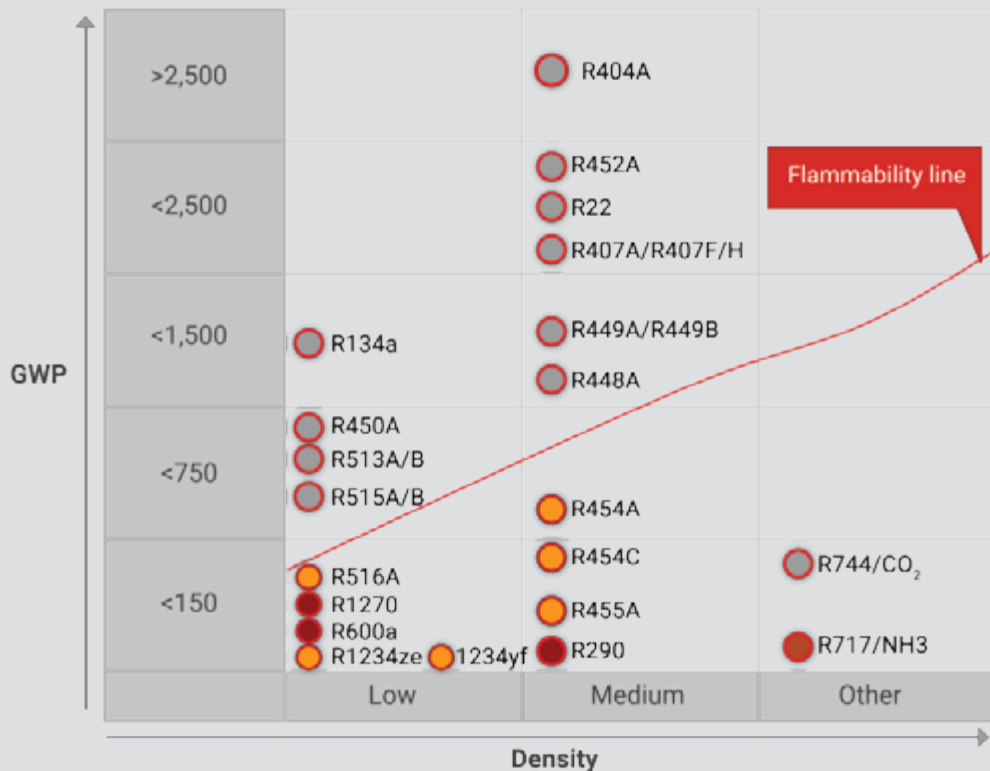
Main alternative refrigerants in play



A picture in continuous evolution



-  A1 - non Flammable
-  A2L - Mildly Flammable
-  A3 - Highly Flammable
-  B1 - Toxic non flammable
-  B2L - Toxic Lower Flammable
-  On the market
-  Not yet on the market

Refrigerant Solutions for Air Conditioning and Heat Pumps



Main alternative refrigerants in play

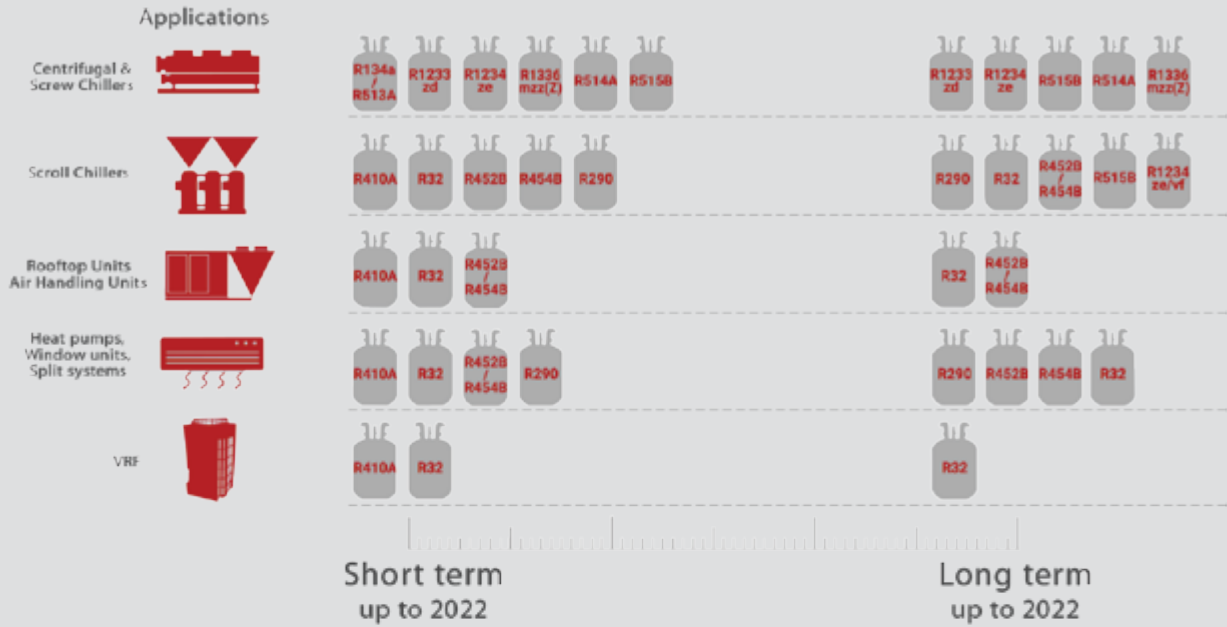

A picture in continuous evolution

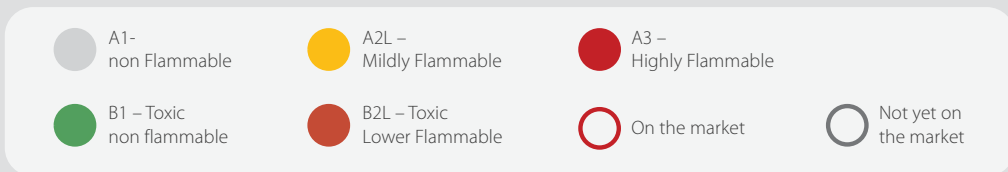
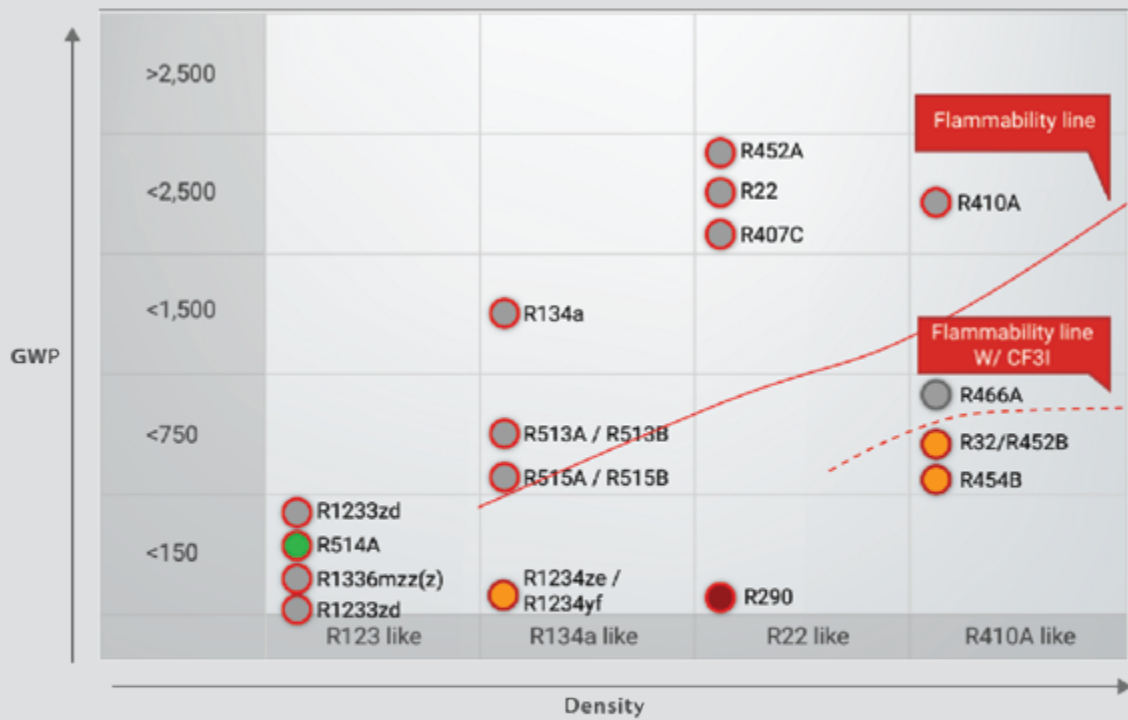

Quick Selection Notes:

While reading this, **Ref Tools** has been used 3 times across the world

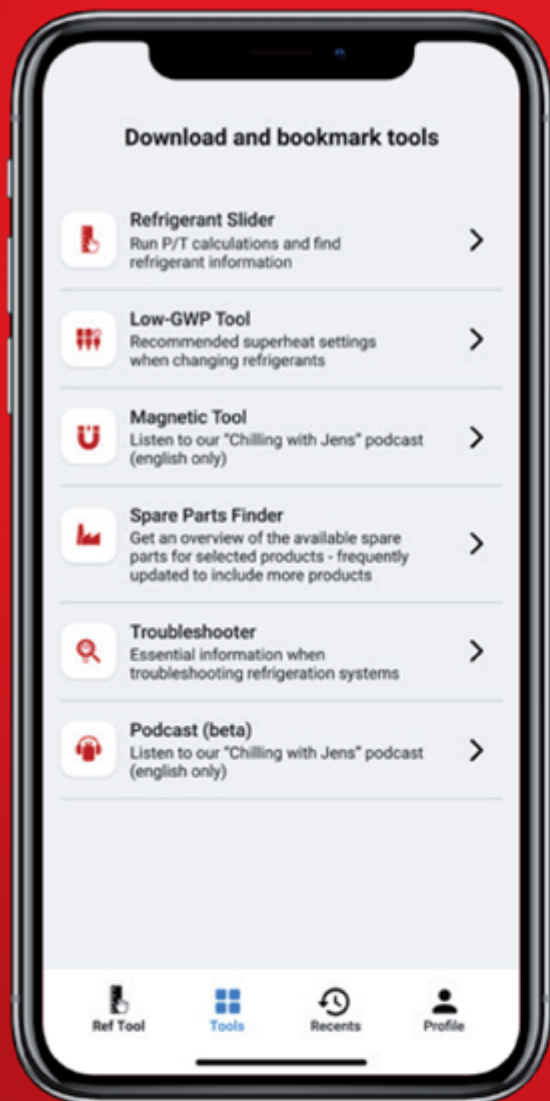

2,000,000 app installs.
Used every 6 seconds.

Get yours today. 

