

Installation Guide

Check valve

Type NRV and NR VH

02.0R9506

02.0R9506

Refrigerants:

For a complete list of approved refrigerants, visit <http://store.danfoss.com/> and search for individual code numbers, where refrigerants are listed as part of product details.

Note: -Flare/face seal connections are only approved for A1 and A2L refrigerants.

Applicable to A1, A2, A2L and A3 refrigerants as accepted by Danfoss, excluding R717 and to non-corrosive gases/liquids dependent on sealing material compatibility. The design pressure shall not be less than the value outlined in section 9.2 of ANSI/ASHRAE 15 for the refrigerant used in the system.

Valve type	Connection type	Media temperature range	Max. working pressure (PS/MWP)
NRV/NRVH 6s-19s	Straight-way - solder	-50 °C - 155 °C / -58 °F - 311 °F	49 bar/ 710 psig
NRV/NRVH 6-19	Straight-way - flare	-50 °C -140 °C / -58 °F - 285 °F	46 bar/ 667 psig
NRV/NRVH 22s-35s	Angle-way - solder	-50 °C -140 °C / -58 °F - 285 °F	46 bar/ 667 psig
NRV/NRVH 22s E-35s E	Angle-way - solder	-50 °C -155 °C / -58 °F - 311 °F	49 bar/ 710 psig
NRV 10s H (CO ₂)	Straight-way - solder	-50 °C -155 °C / -58 °F - 311 °F	90 bar / 1305 psig

Position angleway

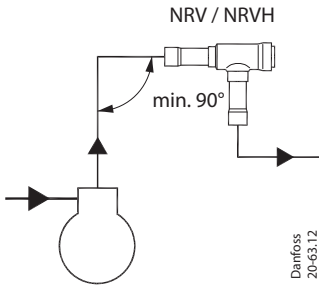

Position straightway

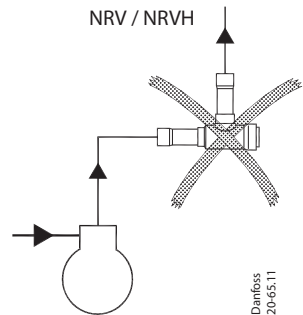
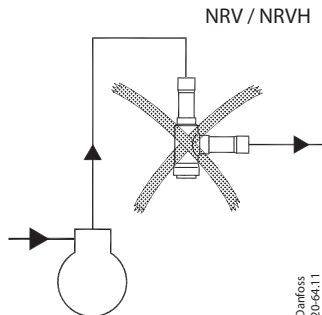
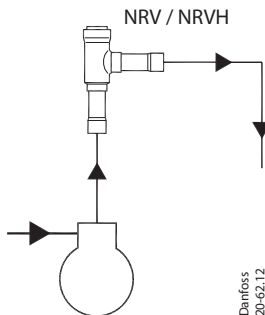
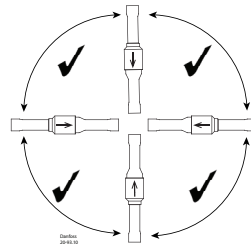

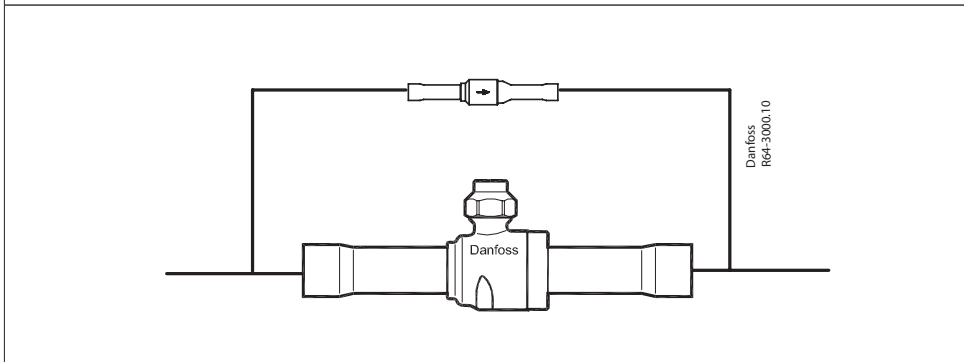
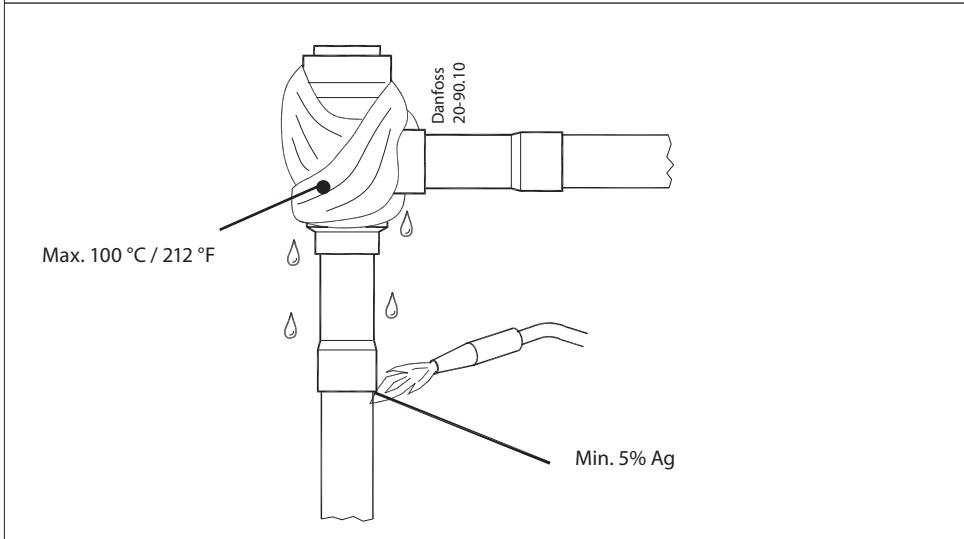
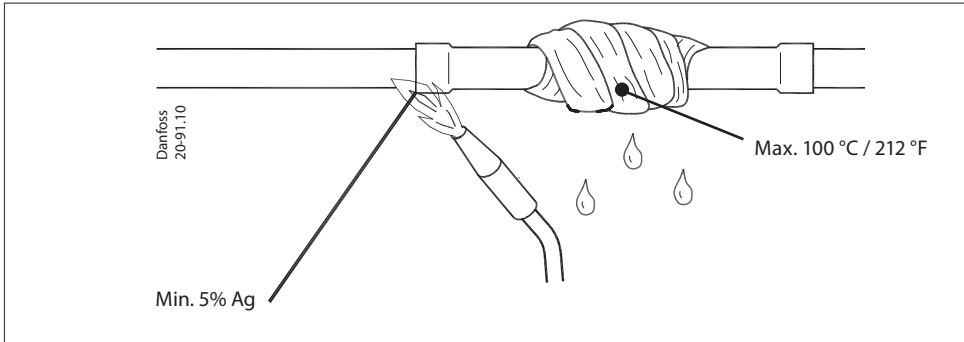

For NRV CO2 valve(90bar), when the NRV is used together with GBC in parallel as a pressure relief valve, it is recommended to install the NRV above the GBC.
 For the application use with R744 as part of a secondary loop or cascade system should refer to the datasheet for more attentions.