



Installation guide

**ELIMINATOR® Hermetic filter drier**

Type DMSC

023R9523

023R9523

**Refrigerant R744 (CO<sub>2</sub>)**  
**(CO<sub>2</sub> for sub-critical application)**

Media Temperature range: -30 °C – 17 °C / -22 °F – 63 °F

PS/MWP: 52 bar / 754 psig

**Pure copper:**  
Size: 1/4, 3/8, 1/2,  
6 mm, 8 mm, 12 mm

**Steel:**  
Size: 1/4, 3/8, 1/2



Keep flames away from body

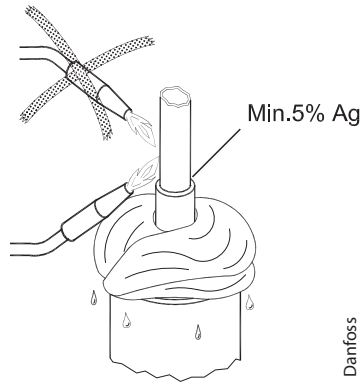

**Customer best practices will still be needed:**

- Use wet wrap when installing.
- Braze the joints
- Let them cool down
- Clean the welding area after the installation (remove remaining flux with a brush)
- This is an important operation and needs to be done with great care to remove all remaining flux.
- Paint/Anti-corrosive needs to cover all open steel parts, areas where the black original paint has been burnt due to brazing and at least 3 cm approx of the copper tube
- Paint the joints twice

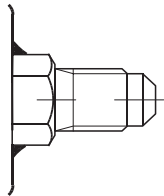

Flare steel connectors



Applies compatible oil on the steel connector (threads)

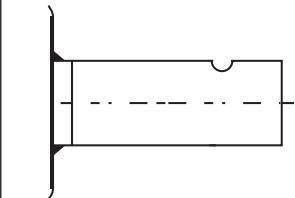
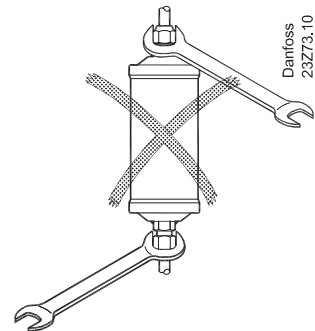
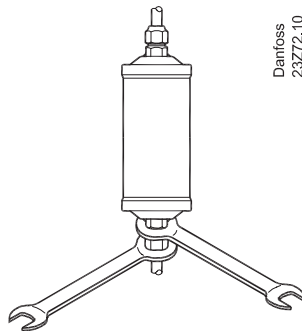

Pure copper extended connectors

When applying the torque wrench to the filter drier fix it so there is no movement. Also avoid movement in the tubing when installing.

