

Instructions

Frequency converter CD302

Inverter reciprocating compressors VTZ

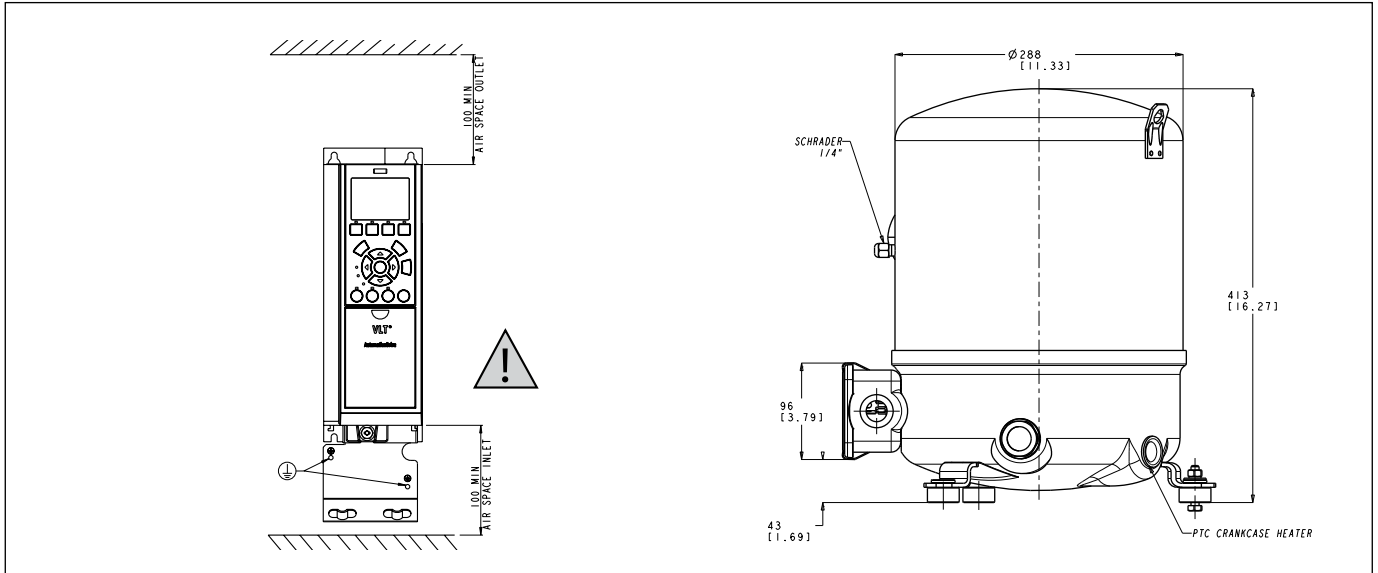

Safety instructions and General Warning

Disposal

Drive:



Equipment containing electrical components may not be disposed together with domestic waste.

It must be separate collected with Electrical and Electronic Waste according to local and currently valid legislation.

Compressors:

Danfoss recommends not to throw away a used compressor but to dispose of the compressor and its oil at a specialised recycling company site

Caution

⚠ The CD 302 Compressor Drive™ DC link capacitors remain charged after power has been disconnected. To avoid an electrical shock hazard, disconnect the CD 302 from the mains before carrying out maintenance. Wait at least as follows before doing service on the frequency converter:
CD 302: ≤ 7.5 kW 4 minutes
CD 302: 11.22 kW 15 minutes

Be aware that there may be high voltage on the DC link even when the LEDs are turned off.

CD302 Operating Instructions Software version: 1.0x



These Operating Instructions can be used for all CD302 Compressor Drives™ with software version 1.0x. The software version number can be seen from parameter 15-43.

High Voltage Warning



The voltage of the CD 302 is dangerous

whenever the converter is connected to mains. Incorrect fitting of the motor or frequency converter may cause damage to the equipment, serious injury or death. Consequently, it is essential to comply with the instructions in this manual as well as local and national rules and safety regulations.

⚠ Safety Instructions

- Make sure the CD 302 is properly connected to earth.
- Do not remove mains plugs or motor plugs while the CD 302 is connected to mains.
- Protect users against supply voltage.
- Protect the motor against overloading according to national and local regulations.
- Motor overload protection is included in the default settings
- The earth leakage current exceeds 3.5 mA.
- The [OFF] key is not a safety switch! It does not disconnect the CD 302 from mains.

General warning

Warning:

Touching the electrical parts may be fatal - even after the equipment has been disconnected from mains.

⚠ Also make sure that other voltage inputs have been disconnected, such as load-sharing (linkage of DC intermediate circuit). Using CD 302 Compressor Drives™: wait at least 15 minutes. Shorter time is allowed only if indicated on the nameplate for the specific unit.

Leakage Current

The earth leakage current from the CD 302 exceeds 3.5 mA. To ensure that the earth cable has a good mechanical connection to the earth connection (terminal 95), the cable cross section must be at least 10 mm² or 2 times rated earth wires terminated separately.

Residual Current Device

This product can cause a D.C. current in the protective conductor. Where a residual current device (RCD) is used for extra protection, only an RCD of Type B (time delayed) shall be used on the supply side of this product. See also RCD Application Note MN.90.GX.02. Protective earthing of the CD 302 and the use of RCD.s must always follow national and local regulations.

IT Mains

Do not connect 400 V frequency converters with RFI-filters to mains supplies with a Voltage between phase and earth of more than 440 V. For IT mains and delta earth (grounded leg), mains voltage may exceed 440 V between phase and earth.

Par. 14-50 RFI 1 can on CD 302 be used to disconnect the internal RFI capacitors from the RFI filter to ground. If this is done it will reduce the RFI performance to A2 level.

Before Commencing Repair Work

1. Disconnect CD 302 from mains
2. Disconnect DC bus terminals 88 and 89
3. Wait for discharge of the DC-link. See period of time on the warning label.
4. Remove motor cable

Avoid Unintended Start

While CD 302 is connected to mains, the motor can be started/stopped using digital commands, bus commands, references or via the Local Control Panel (LCP).

- Disconnect the CD 302 from mains whenever personal safety considerations make it necessary to avoid unintended start.
- To avoid unintended start, always activate the [OFF] key before changing parameters.
- An electronic fault, temporary overload, a fault in the mains supply, or lost motor connection

Instructions

may cause a stopped motor to start. CD 302 with Safe Stop provides a certain degree of protection against such unintended start, if the Safe Stop Terminal 37 is on low voltage level or disconnected.

Safe Stop of CD 302

The CD 302 can perform the safety function Safe Torque Off (As defined by draft IEC 61800-5-2) or Stop Category 0 (as defined in EN 60204-1). It is designed and approved suitable for the requirements of Safety Category 3 in EN 954-1.

This functionality is called Safe Stop. Prior to integration and use of Safe Stop in an installation, a thorough risk analysis on the installation must be carried out in order to determine whether the Safe Stop functionality and safety category are appropriate and sufficient. In order to install and use the Safe Stop function in accordance with the requirements of Safety Category 3 in EN 954-1, the related information and instructions of the CD 302 Design Guide must be followed!

The information and instructions of the Operating Instructions are not sufficient for a correct and safe use of the Safe Stop functionality!

General Specifications

Mains supply (L1, L2, L3)

- Supply voltage: 200-240 V $\pm 10\%$
- Supply voltage: 380-480 V $\pm 10\%$
- Supply voltage: 525-600 V $\pm 10\%$
- Supply frequency: 50/60 Hz
- Maximbalance temporary between mains phases: 3.0 % of rated supply voltage
- True Power Factor (λ): ≥ 0.9 nominal at rated load
- Displacement Power Factor ($\cos \phi$) near unity: (> 0.98)
- Switching on input supply L1, L2, L3 (power-ups) ≤ 7.5 kW: maximum 2 times/min.
- Switching on input supply L1, L2, L3 (power-ups) ≥ 11 kW: maximum 1 time/min.
- Environment according to EN60664-1: overvoltage category III/pollution degree 2

The unit is suitable for use on a circuit capable of delivering not more than 100.000 RMS symmetrical Amperes, 240/500/600 V maximum.

Motor compressor output (U, V, W)

- Output voltage: 0 - 100% of supply voltage
- Switching on output: see param number 14-01 in table page 28.

Digital inputs

- Voltage level: 0 - 24 V DC
- Voltage level, logic.0. PNP: < 5 V DC
- Voltage level, logic.1. PNP: > 10 V DC
- Voltage level, logic.0. NPN2): > 19 V DC
- Voltage level, logic.1. NPN2): < 14 V DC
- Maximum voltage on input: 28 V DC
- Input resistance, Ri: approx. 4 k Ω

Safe stop Terminal 37

Terminal 37 is fixed PNP logic

- Voltage level: 0 - 24 V DC
- Voltage level, logic.0. PNP: < 4 V DC
- Voltage level, logic.1. PNP: > 20 V DC
- Nominal input current at 24 V: 50 mA rms
- Nominal input current at 20 V: 60 mA rms
- Input capacitance: 400 nF

All digital inputs are galvanically isolated from the supply voltage (PELV) and other high-voltage terminals.

1) Terminals 27 and 29 can also be programmed as output.

2) Except safe stop input Terminal 37.

3) Terminal 37 can only be used as safe stop input. Terminal 37 is suitable for category 3 installations according to EN 954-1 (safe stop according to category 0 EN 60204-1) as required by the EU Machinery Directive 98/37/EC. Terminal 37 and the Safe Stop function are designed in conformance with EN 60204-1, EN 50178, EN 61800-2, EN 61800-3, and EN 954-1. For correct and safe use of the Safe Stop function follow the related information and instructions in the Design Guide.

Analog inputs

- Number of analog inputs: 2
- Terminal number: 53, 54
- Modes: Voltage or current
- Mode select: Switch S201 and switch S202
- Voltage mode: Switch S201/switch S202 = OFF (U)
- Voltage level: -10 to +10 V (scaleable)
- Input resistance, Ri: approx. 10 k Ω
- Max. voltage: ± 20 V
- Current mode: Switch S201/switch S202 = ON (I)
- Current level: 0/4 to 20 mA (scaleable)
- Input resistance, Ri: approx. 200 Ω
- Max. current: 30 mA
- Resolution for analog inputs: 10 bit (+ sign)
- Accuracy of analog inputs: Max. error 0.5% of full scale
- Bandwidth: 100 Hz

The analog inputs are galvanically isolated from the supply voltage (PELV) and other high-voltage terminals.

Digital output

- Programmable digital/pulse outputs: 2
- Terminal number: 27, 29
- Voltage level at digital/frequency output: 0 - 24 V
- Max. output current (sink or source): 40 mA
- Max. load at frequency output: 1 k Ω
- Max. capacitive load at frequency output: 10 nF
- Minimum output frequency at frequency output: 0 Hz
- Maximum output frequency at frequency output: 32 kHz
- Accuracy of frequency output: Max. error: 0.1 % of full scale
- Resolution of frequency outputs: 12 bit

1) Terminal 27 and 29 can also be programmed as input.

The digital output is galvanically isolated from the supply voltage (PELV) and other high-voltage terminals.

Analog output

- Number of programmable analog outputs: 1
 - Terminal number: 42
 - Current range at analog output: 0/4 - 20 mA
 - Max. load to common at analog output: 500 Ω
 - Accuracy on analog output: Max. error: 0.5 % of full scale
 - Resolution on analog output: 12 bit
- The analog output is galvanically isolated from the supply voltage (PELV) and other high-voltage terminals.

Control card, 24 V DC output

- Terminal number: 12, 13
 - Max. load: 200 mA
- The 24 V DC supply is galvanically isolated from the supply voltage (PELV), but has the same po-

tential as the analog and digital inputs and outputs.

Control card, 10 V DC output

- Terminal number: 50
- Output voltage: 10.5 V ± 0.5 V
- Max. load: 15 mA

The 10 V DC supply is galvanically isolated from the supply voltage (PELV) and other high-voltage terminals.

Control card, RS 485 serial communication

- Terminal number: 68 (P,TX+, RX+), 69 (N,TX-, RX-)
- Terminal number 61: Common for terminals 68 and 69

The RS 485 serial communication circuit is functionally separated from other central circuits and galvanically isolated from the supplier voltage (PELV).

Control card, USB serial communication

- USB standard: 1.1 (Full speed)
 - USB plug: USB type B device plug
- Connection to PC is carried out via a standard host/device USB cable.

The USB connection is galvanically isolated from the supply voltage (PELV) and other high-voltage terminals. The USB ground connection is not galvanically isolated from protection earth. Use only isolated laptop as PC connection to the USB connector on CD 302 drive.

Relay outputs

- Programmable relay outputs: 2
- Relay 01 Terminal number: 1-3 (break), 1-2 (make)
- Max. terminal load (AC-1)1) on 1-3 (NC), 1-2 (NO) (Resistive load): 240 V AC, 2 A
- Max. terminal load (AC-15)1) (Inductive load @ $\cos \phi 0.4$): 240 V AC, 0.2 A
- Max. terminal load (DC-1)1) on 1-2 (NO), 1-3 (NC) (Resistive load): 60 V DC, 1 A
- Max. terminal load (DC-13)1) (Inductive load): 24 V DC, 0.1 A
- Relay 02 (CD 302 only) Terminal number: 4-6 (break), 4-5 (make)
- Max. terminal load (AC-1)1) on 4-5 (NO) (Resistive load): 400 V AC, 2 A
- Max. terminal load (AC-15)1) on 4-5 (NO) (Inductive load @ $\cos \phi 0.4$): 240 V AC, 0.2 A
- Max. terminal load (DC-1)1) on 4-5 (NO) (Resistive load): 80 V DC, 2 A

How to install

Mechanical Installation

Find the following parts included in the CD302 Accessory Bag.

- Accessory Bag ≤ 7.5 kW

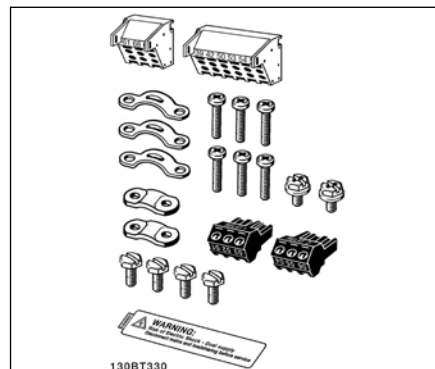

Instructions

• Accessory Bag ≤ 7.5 kW, IP55

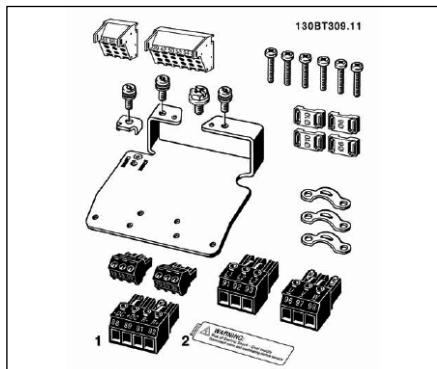

• Accessory Bag 11 – 22 kW

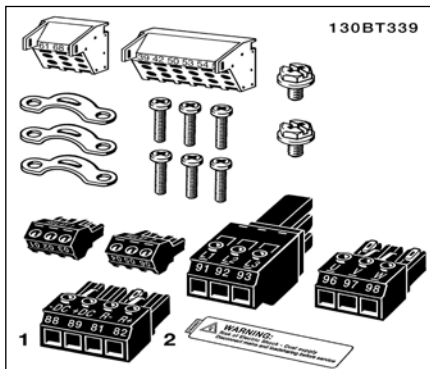

CD 302 IP20 allows side-by-side installation. Because of the need for cooling, there must be a minimum of 100 mm free air passage above and below the CD 302.

The back wall must always be solid. All CD302 are equipped of a back metal plate to guarantee proper heat exchanger ventilation. Never remove this metal sheet.

Safety Requirements of Mechanical Installation

The frequency converter is cooled by means of air circulation.

To protect the unit from overheating, it must be ensured that the ambient temperature does not exceed the maximum temperature stated for the frequency converter and that the 24-hour average temperature is not exceeded. If the ambient temperature is in the range of 45°C - 55°C, derating of the frequency converter will become relevant. The service life of the frequency converter is reduced if derating for ambient temperature is not taken into account.

Mechanical mounting

- 1) Drill holes in accordance with the measurements given.
- 2) You must provide screws suitable for the surface on which you want to mount the CD 302. Retighten all four screws.

Mechanical Dimension

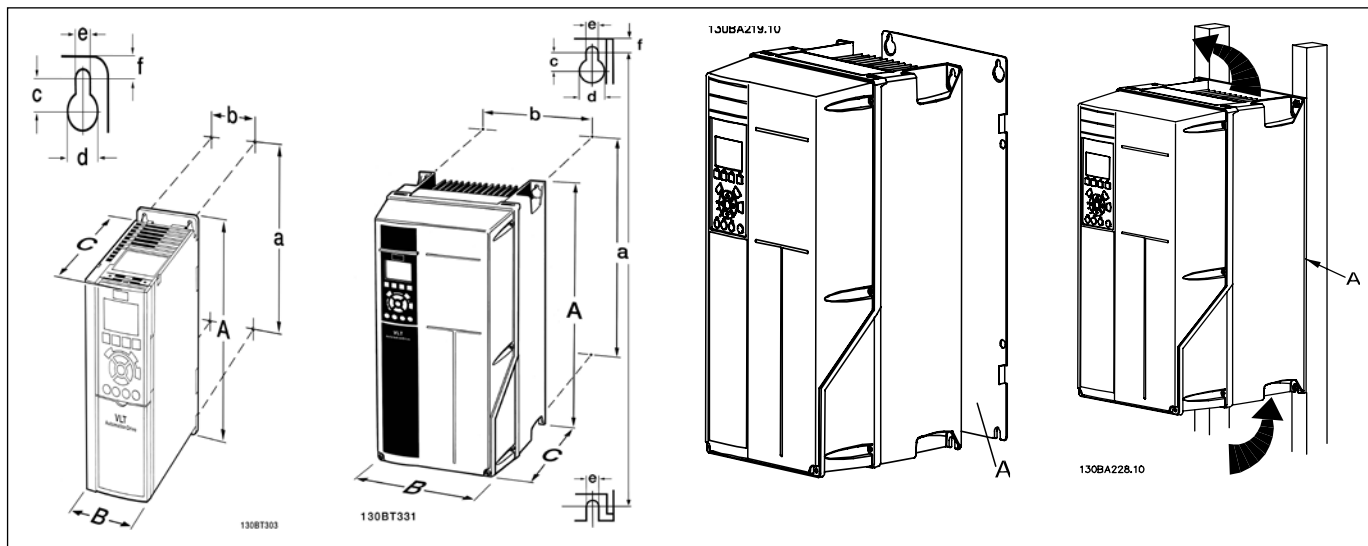

Mechanical dimensions						
		Frame size A2	Frame size A3	Frame size A5	Frame size B1	Frame size B2
		4.0 kW (380-480 V) 4 kW (525-600 V)	3.0 kW (200-240 V) 5.5 - 7.5 kW (380-480 V) 5.5 - 7.5 kW (525-600 V)	4.0 kW (200-240 V) 4.0 - 7.5 kW (380-480 V)	5.5 - 7.5 kW (200-240 V) 11-15 kW (380-480 V)	11kW (200-240 V) 18.5-22 kW (380-480 V)
		IP 20	IP 20	IP 55	IP 21 / IP 55	IP 21 / IP 55
Height						
Height of black plate	A	268 mm	268 mm	420 mm	480 mm	650 mm
Distance between mounting holes	a	257 mm	257 mm	402 mm	454 mm	624 mm
Width						
Width of black plate	B	90 mm	130 mm	242 mm	242 mm	242 mm
Distance between mounting holes	b	70 mm	110 mm	215 mm	210 mm	210 mm
Depth						
Depth without option A/B	C	205 mm	205 mm	195 mm	260 mm	260 mm
Depth with option A/B	C	220 mm	220 mm	195 mm	260 mm	260 mm
Screw holes						
	c	8.0 mm	8.0 mm	8.25 mm	12 mm	12 mm
	d	ø 11 mm	ø 11 mm	ø 12 mm	ø 19 mm	ø 19 mm
	e	ø 5.5 mm	ø 5.5 mm	ø 6.5 mm	ø 9 mm	ø 9 mm
	f	9 mm	9 mm	9 mm	9 mm	9 mm

Instructions

Electrical installation

△ Cables general

Always comply with national and local regulations on cable cross-sections.

Tightening-up Torque		
CD size	Cable for:	Tightening up torque
3-7.5 kW	Line, load sharing motor Compressor cable	1.8 Nm
11-22 kW	Line, load sharing motor compressor cable	1.8 Nm
11-22 kW	Motor compressor cable	1.8 Nm
	Relay	0.5 - 0.6 Nm
	Earth	2 - 3 Nm

• Removal of knockouts for extra cables

- Remove cable entry from the frequency converter (Avoiding foreign parts in the frequency converter when removing knockouts)
- Cable entry has to be supported around the knockout you intend to remove.
- The knockout can now be removed with a strong mandrel and a hammer.
- Remove burrs from the hole.
- Mount Cable entry on frequency converter.

• Connection to Mains and Earthing

How to connect to mains and earthing (A2 and A3 enclosure).

- Make sure the CD 302 is properly earthed. Connect to earth connection (terminal 95). Use screw from the accessory bag.
- Place plug connector 91, 92, 93 from the accessory bag onto the terminals labelled MAINS at the bottom of CD302.
- Connect mains wires to the mains plug connector.

How to connect to mains and earthing (B1 and B2 enclosure)

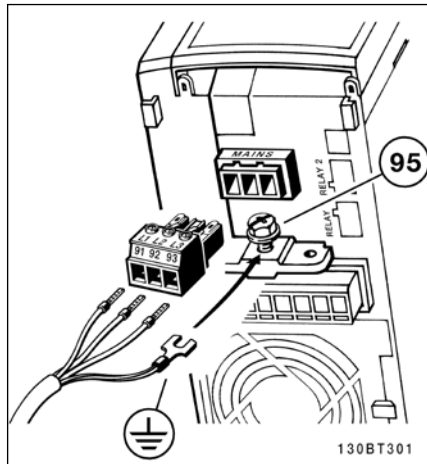

• IT Mains

Check that mains voltage corresponds to the mains voltage of the CD302 name plate. L1, L2, L3 mains have to be connected preferably clockwise direction

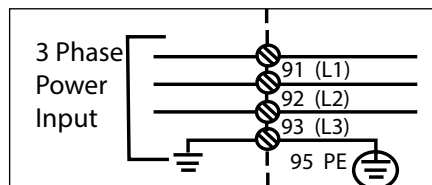

• Motor compressor connection

Motor compressor cable must be screened / armoured. If an unscreened / unarmoured cable is used, some EMC requirements are not complied with. For more information, see EMC specifications.

- Fasten decoupling plate to the bottom of CD302 with screws and washers from the accessory bag.
- Attach motor compressor cable to terminals 96 (U), 97 (V), 98 (W).
- Connect to earth connection (terminal 99) on decoupling plate with screws from the accessory bag.
- Insert terminals 96 (U), 97 (V), 98 (W) and motor compressor cable to terminals labelled MOTOR. Fasten screened cable to decoupling plate with screws and washers from the accessory bag.

U, V, W for motor compressor need to be clockwise connected. Note that VTX compressors can rotate on both directions, but when used in manifolded systems all compressors must have the same rotation direction to avoid vibration interferences.

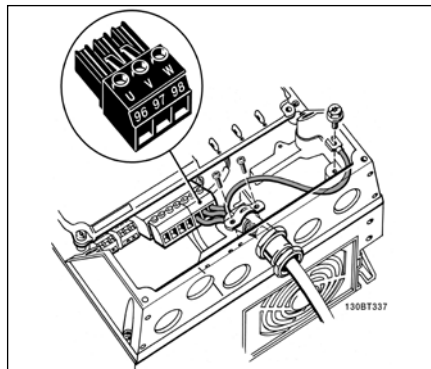

≤7.5 kW IP 55

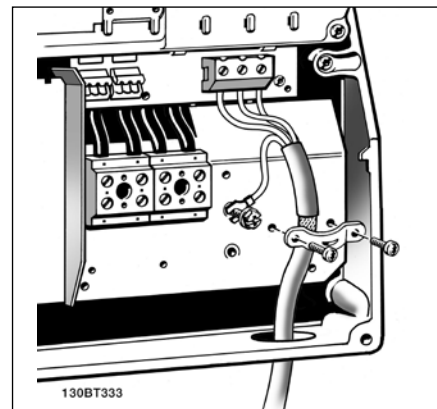

11 - 22 kW IP 21/55

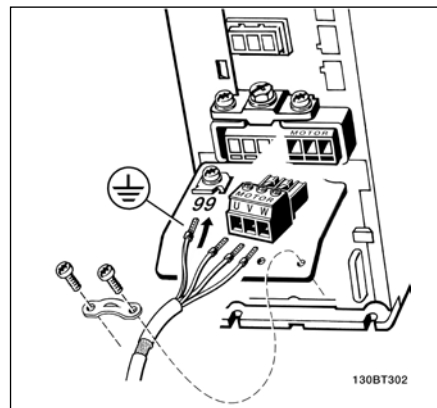

≤7.5 kW IP 20

• Motor compressors cables

Correct dimensioning of motor compressor cable cross-section and length is described in the application manual.

- Use a screened/armoured motor compressor cable to comply with EMC emission specifications.
- Keep the motor compressor cable as short as possible to reduce the noise level and leakage currents.
- Connect the motor compressor cable screen to both the decoupling plate of the CD302 and to the metal cabinet of the motor compressor.
- Make the screen connections with the largest possible surface area (cable clamp). This is done by using the supplied installation devices in the CD302.

• Electrical installation of motor compressor cables

- Screening of cables :

Avoid installation with twisted screen ends (pig-tails). They spoil the screening effect at higher frequencies. If it is necessary to break the screen to install a motor compressor isolator or motor compressor contactor, the screen must be continued at the lowest possible HF impedance.

- Cable length and cross-section :

The frequency converter has been tested with a given length of cable and a given cross-section of that cable. If the cross-section is increased, the cable capacitance - and thus the leakage current - may increase, and the cable length must be reduced correspondingly.

- Switching frequency : The switching frequency is factory set at 3.5 kHz.

- Aluminium conductors : Aluminium conduc-

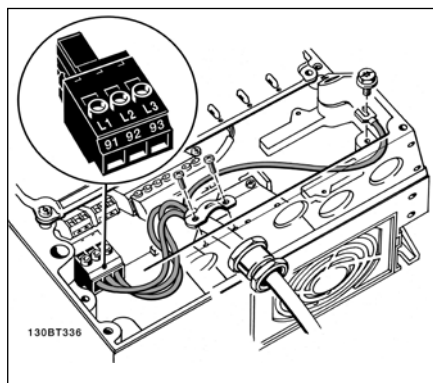

Connection to Mains and Earthing

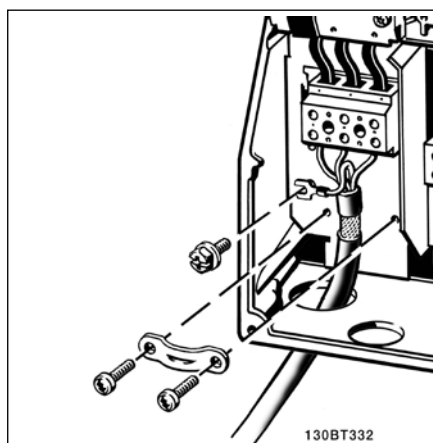

Instructions

tors are not recommended. Terminals can accept aluminium conductors but the conductor surface has to be clean and the oxidation must be removed and sealed by neutral acid free Vase-

line grease before the conductor is connected. Furthermore, the terminal screw must be retightened after two days due to the softness of the aluminium. It is crucial to keep the connection a

gas tight joint, otherwise the aluminium surface will oxidize again.

• Fuses

- Branch circuit protection:

In order to protect the installation against electrical and fire hazard, all branch circuits in an installation, switch gear, machines etc., must be shortcircuit and overcurrent protected according to the national/international regulations.

- Short circuit protection:

The frequency converter must be protected

against short-circuit to avoid electrical or fire hazard. Danfoss recommends using the fuses mentioned below to protect service personnel or other equipment in case of an internal failure in the drive. The frequency converter provides full short circuit protection in case of a short-circuit on the motor compressor output.

- Over current protection:

Provide overload protection to avoid fire hazard

due to overheating of the cables in the installation. The frequency converter is equipped with an internal over current protection that can be used for upstream overload protection (UL-applications excluded). See par. 4-18. Moreover, fuses or circuit breakers can be used to provide the over current protection in the installation. Over current protection must always be carried out according to national regulations.

- UL compliance (380-480V, 525-600V)

CD 302	Bussmann			SIBA	Littel fuse	Ferraz- Shawmut	
kW	Type RK1	Type J	Type T	Type RK1	Type K1	Type CC	Type RK1
4.0	KTS-R20	JKS-20	JJS-20	5017906-020	KLS-R20	ATM-R20	A6K-20R
5.5-7.5	KTS-R30	JKS-30	JJS-30	5012406-32	KLS-R30	ATM-R30	A6K-30R
11.0	KTS-R40	JKS-40	JJS-40	5014006-040	KLS-R40		A6K-40R
15.0	KTS-R50	JKS-50	JJS-50	5014006-50	KLS-R50		A6K-50R
18.0	KTS-R60	JKS-60	JJS-60	5014006-63	KLS-R60		A6K-60R
22.0	KTS-R80	JKS-80	JJS-80	100 KLS-R80	KLS-R80		A6K-80R

- Non UL compliance :

If UL/cUL is not to be complied with, we recommend using the following fuses, which will ensure compliance with EN50178. In case of malfunction, not following the recommendation may result in unnecessary damage of the frequency converter.

CD 302	Max. fuse size	Voltage	Type
3K0-3K7	32A*	200-240V	type gG
3K0-4K0	20A*	380-480V	type gG
5K5-7K5	32A*	380-480V	type gG
11K	63A*	380-480V	type gG
15K	63A*	380-480V	type gG
18K	63A*	380-480V	type gG
22K	80A*	380-480V	type gG

*: Max. fuses - see national/ international regulations for selecting an applicable fuse size.

• Electrical motor compressor protection

The electrical motor compressor protection is fully provided by the CD302 frequency converter. - CD302 makes through an Electronic current measurement anti-overload and lock-rotor motor compressor protection (see description in the application manual).

- The frequency converter is protected against short-circuits on compressor terminals U, V, W.

- If a mains phase is missing, the frequency converter trips or issues a warning (depending on the load).

- If a motor compressor phase is missing, the frequency converter trips.

- The frequency converter is protected against earth faults on compressor terminals U, V, W.

- The frequency converter is protected against short circuits on compressor terminals U, V, W.

- Monitoring of the intermediate circuit voltage ensures that the frequency converter trips if the intermediate circuit voltage is too low or too high.

• Access to Control Terminals

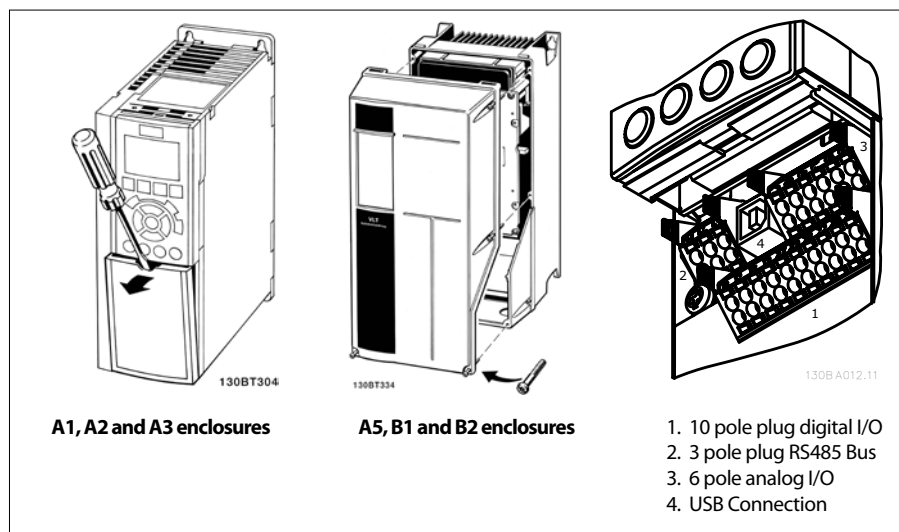

A1, A2 and A3 enclosures

A5, B1 and B2 enclosures

- 10 pole plug digital I/O
- 3 pole plug RS485 Bus
- 6 pole analog I/O
- USB Connection

Instructions

To mount the cable to the terminal:

1. Strip isolation of 9-10 mm
2. Insert a screw driver in the square hole.
3. Insert the cable in the adjacent circular hole.
4. Remove the screw driver. The cable is now mounted to the terminal.

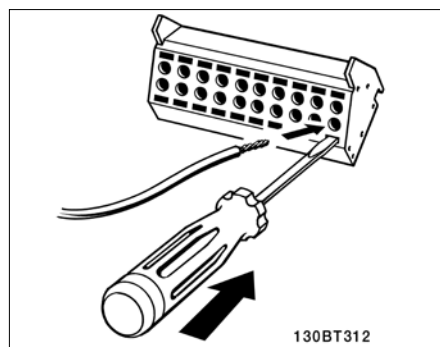
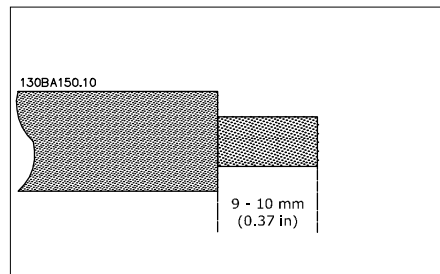

To remove the cable from the terminal:

1. Insert a screw driver in the square hole.
2. Pull out the cable.

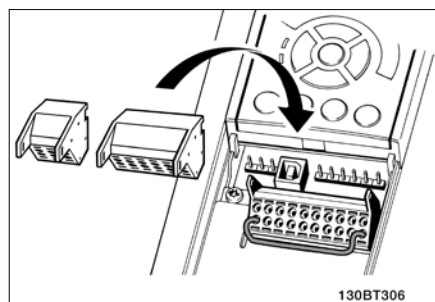
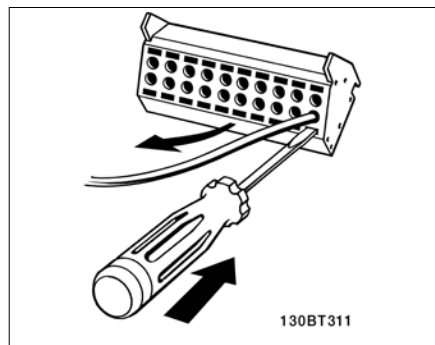

• Basic Wiring Example

1. Mount terminals from the accessory bag to the front of the CD 302.
2. Connect terminals 18, 27 and 37 to +24V (terminal 12/13)

Default settings:

- 18 = start
- 27 = coast inverse
- 37 = safe stop inverse

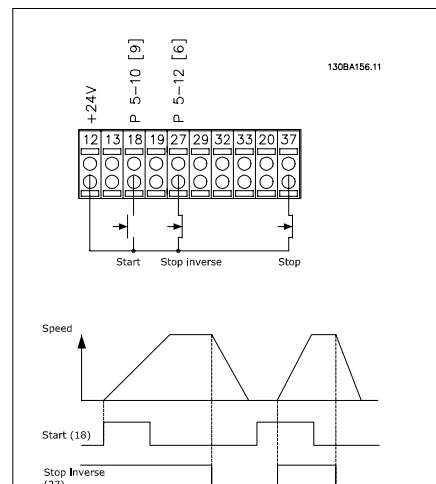

Instructions

Diagram showing all electrical terminals.
Terminal 37 is the input to be used for Safe Stop. Very long control cables and analog signals may in rare cases and depending on installation result in 50/60 Hz earth loops due to noise from mains

supply cables. If this occurs, you may have to break the screen or insert a 100 nF capacitor between screen and chassis. The digital and analog in- and outputs must be

connected separately to the CD302 common inputs (terminal 20, 55, 39) to avoid ground currents from both groups to affect other groups. For example, switching on the digital input may disturb the analog input signal.

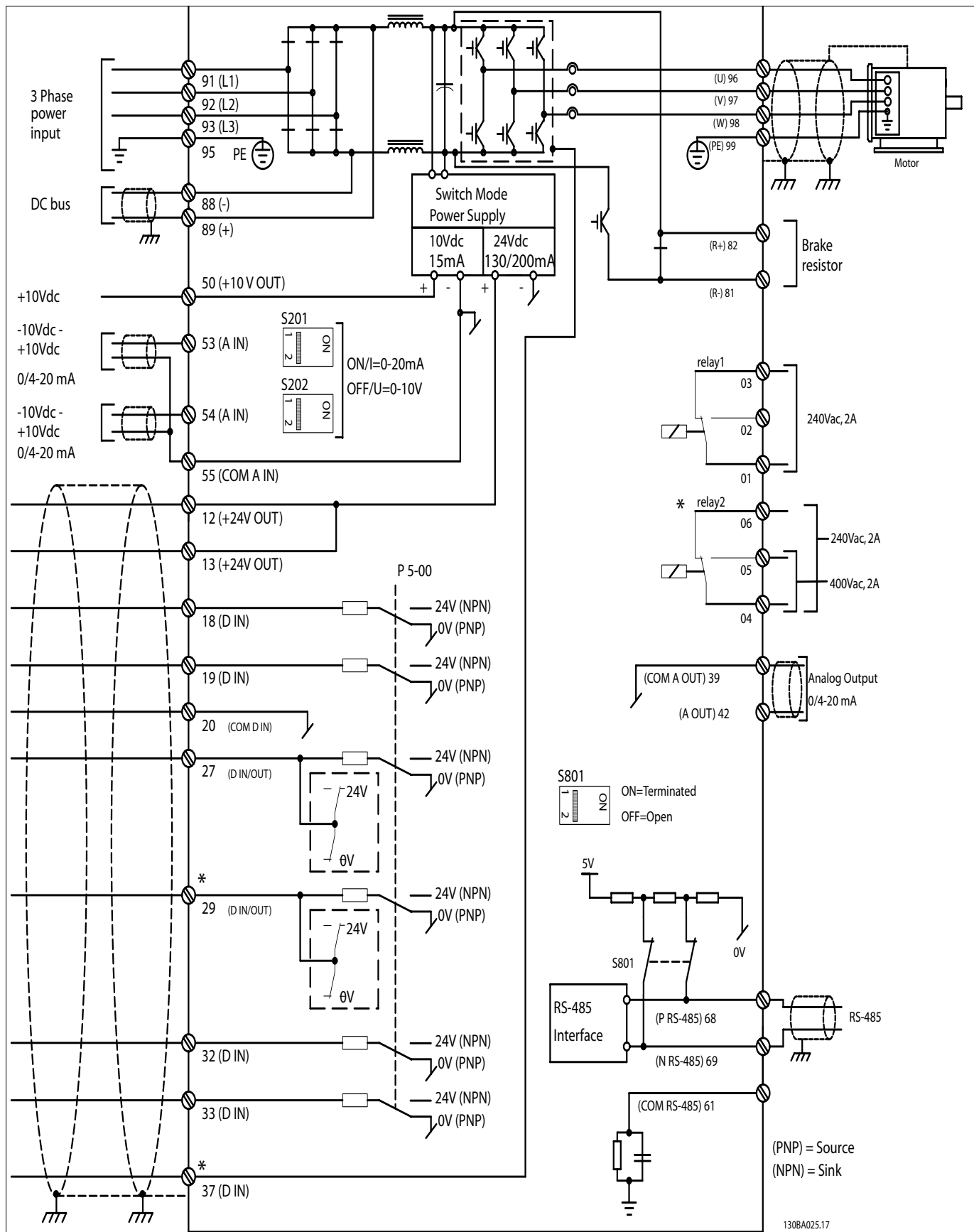

Instructions

- Control cables must be screened/armoured. Use a clamp from the accessory bag to connect the screen to the CD 302 decoupling plate for control cables.

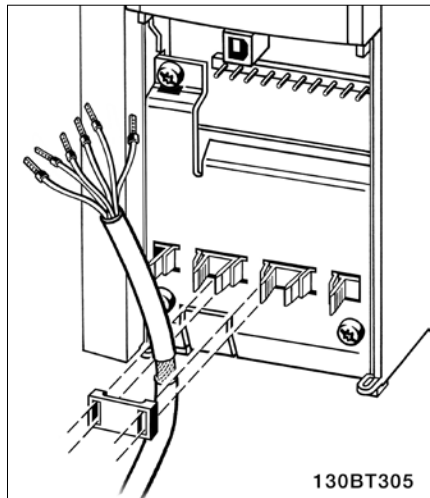

Generally speaking, control cables must be braided screened/armoured and the screen must be connected by means of a cable clamp at both ends to the metal cabinet of the unit. The drawing indicates how correct earthing is carried out and what to do if in doubt.

a. Correct earthing

Control cables and cables for serial communication must be fitted with cable clamps at both ends to ensure the best possible electrical contact.

b. Wrong earthing

Do not use twisted cable ends (pigtailed). They increase the screen impedance at high frequencies.

c. Protection with respect to earth potential between PLC(Program Logic Controller) and CD 302

If the earth potential between the frequency converter and the PLC (etc.) is different, electric noise may occur that will disturb the entire system. Solve this problem by fitting an equalising cable, next to the control cable. Minimum cable cross-section: 16mm².

d. For 50/60 Hz earth loops

If very long control cables are used, 50/60 Hz earth loops may occur. Solve this problem by connecting one end of the screen to earth via a 100nF capacitor (keeping leads short).

e. Cables for serial communication

Eliminate low-frequency noise currents between two frequency converters by connecting one end of the screen to terminal 61. This terminal is connected to earth via an internal RC link. Use twisted-pair cables to reduce the differential mode interference between the conductors.

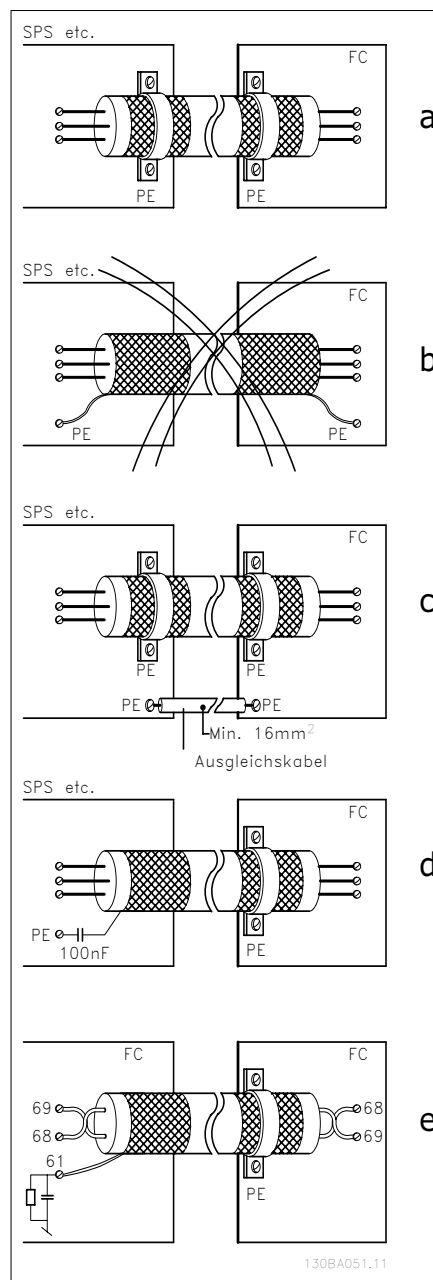

• Safe Stop Installation

To carry out an installation of a Category 0 Stop (EN60204) in conformance with Safety Category 3 (EN954-1), follow these instructions:

1. The bridge (jumper) between Terminal 37 and 24 V DC of CD 302 must be removed. Cutting or breaking the jumper is not sufficient. Remove it entirely to avoid short-circuiting. See jumper on illustration.

2. Connect terminal 37 to 24 V DC by a short-circuit protected cable. The 24 V DC voltage supply must be interruptible by an EN954-1 Category 3 circuit interrupt device. If the interrupt device and the frequency converter are placed in the same installation panel, you can use a regular cable instead of a protected one.

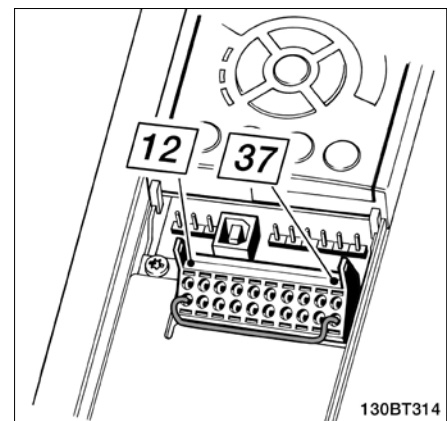

• Electrical Installation - EMC protection

The following is a guideline to good engineering practice when installing frequency converters.

Follow these guidelines to comply with EN 61800-3 First environment. If the installation is in EN 61800-3 Second environment, i.e. industrial networks, or in an installation with its own transformer, deviation from these guidelines is allowed but not recommended. See also paragraphs CE Labelling, General Aspects of EMC Emission and EMC Test Results.

Good engineering practice to ensure EMC-correct electrical installation:

- Use only braided screened/armoured motor compressor cables and braided screened/armoured control cables. The screen should provide a minimum coverage of 80%. The screen material must be metal, not limited to but typically copper, aluminium, steel or lead. There are no special requirements for the mains cable.

- Installations using rigid metal conduits are not required to use screened cable, but the motor compressor cable must be installed in conduit separate from the control and mains cables. Full connection of the conduit from the drive to the motor compressor is required. The EMC performance of flexible conduits varies a lot and information from the manufacturer must be obtained.
- Connect the screen/armour/conduit to earth at both ends for motor compressor cables as well as for control cables.

In some cases, it is not possible to connect the screen in both ends. If so, connect the screen at the frequency converter. See also Earthing of Braided Screened/Armoured Control Cables.

- Avoid terminating the screen/armour with twisted ends (pigtailed). It increases the high frequency impedance of the screen, which reduces its effectiveness at high frequencies. Use low impedance cable clamps or EMC cable glands instead.
- Avoid using unscreened/unarmoured motor compressor or control cables inside cabinets housing the drive(s), whenever this can be avoided.

Leave the screen as close to the connectors as possible.

The illustration shows an example of an EMC-correct electrical installation of an IP 20 frequency converter.

The frequency converter is fitted in an installation cabinet with an output contactor and connected to a PLC, which is installed in a separate cabinet.

Instructions

Other ways of doing the installation may have just as good an EMC performance, provided the above guidelines to engineering practice are followed.

If the installation is not carried out according to the guideline and if unscreened cables and control wires are used, some emission require-

ments are not complied with, although the immunity requirements are fulfilled. See the paragraph EMC test results.

• EMC Correct Installation of an IP20 CD302

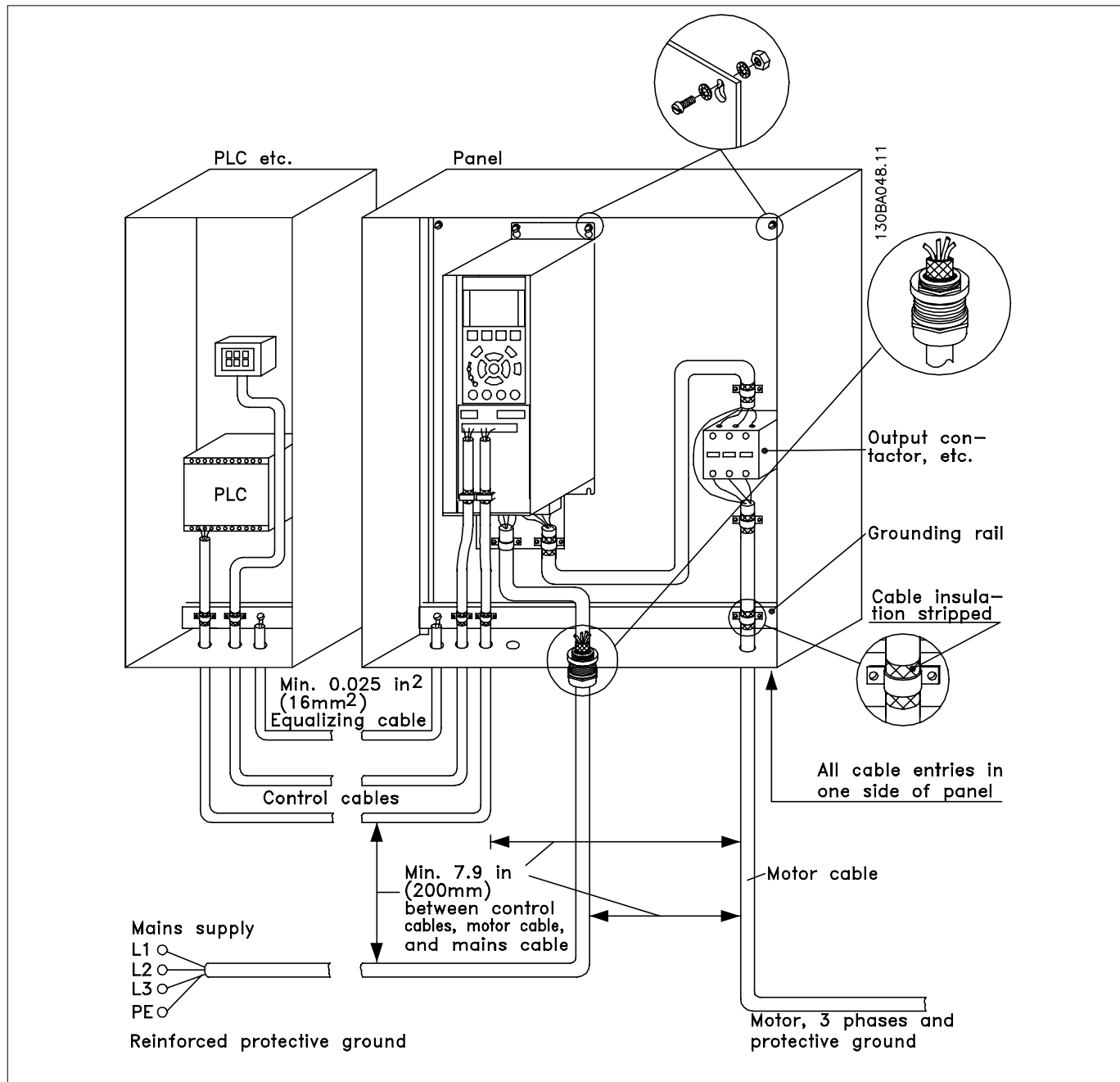

• Safety earth connection

The frequency converter has a high leakage current and must be earthed appropriately for safety reasons according to EN 50178.

The earth leakage current from the frequency converter exceeds 3.5 mA. To ensure a good mechanical connection from the earth cable to the earth connection (terminal 95), the cable cross-

section must be at least 10 mm² or 2 rated earth wires terminated separately.

Instructions

• Basic examples of control connections

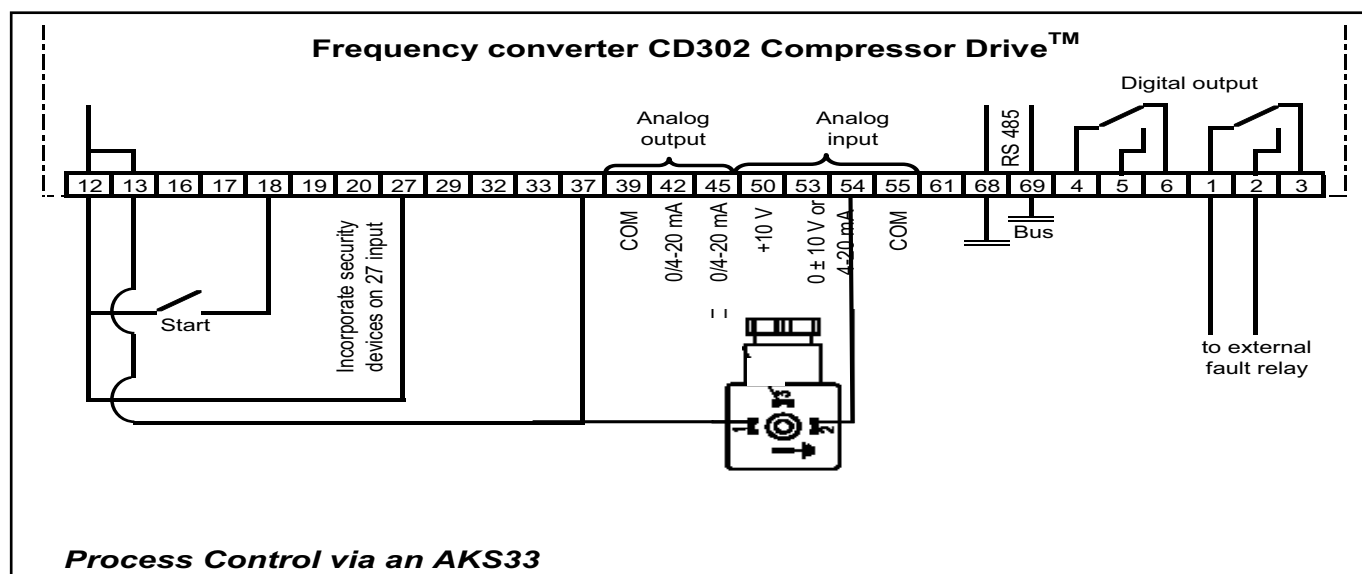
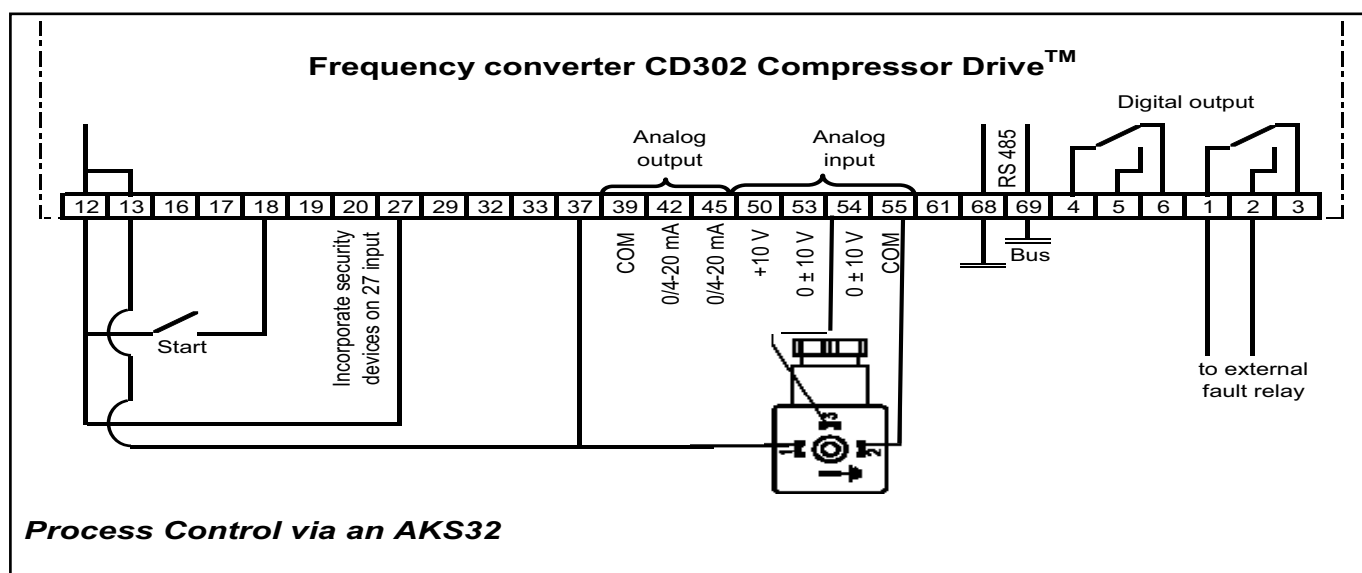
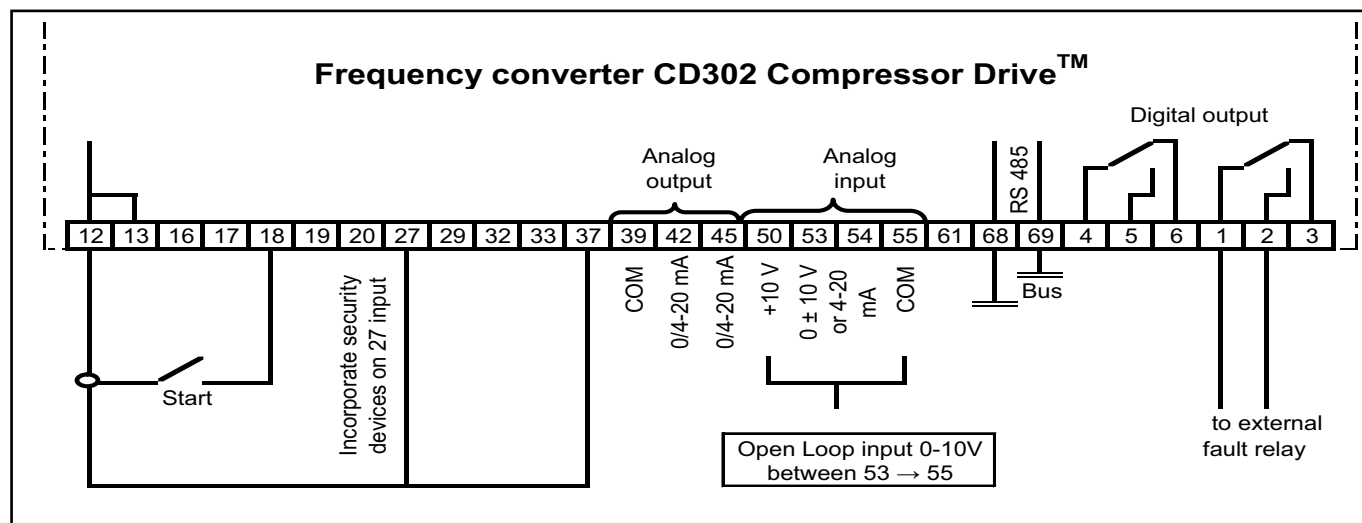

Instructions

Commissioning & final tests

Final Set-Up and Test

To test the set-up and ensure that the frequency converter is running, follow these steps.

Safe Stop Commissioning Test

After installation and before first operation, perform a commissioning test of an installation or application making use of CD 302 Safe Stop. Moreover, perform the test after each modification of the installation or application, which the CD 302 Safe Stop is part of.

The commissioning test:

1. Remove the 24 V DC voltage supply to terminal 37 by the interrupt device while the motor com-

pressor is driven by the CD 302 (i.e. mains supply is not interrupted). The test step is passed if the motor compressor reacts with a coast.

2. Then send Reset signal (via Bus, Digital I/O, or [Reset] key). The test step is passed if the motor compressor remains in the Safe Stop state.

3. Then reapply 24 V DC to terminal 37. The test step is passed if the motor compressor remains in the coasted state.

4. Then send Reset signal (via Bus, Digital I/O, or [Reset] key). The test step is passed if the motor compressor gets operational again.

5. The commissioning test is passed if all four test steps are passed.

High Voltage Test

Carry out a high voltage test by short-circuiting terminals U, V, W, L1, L2 and L3. Energize by max. 2.15 kV DC for one second between this short-circuit and the chassis.

NB: When running high voltage tests of the entire installation, CD302 compressor Drive and compressor electrical motor compressor test can be conducted together.

⚠ Warning: when conducting an high voltage test make sure the system is not under vacuum: this may cause electrical motor compressor failure.

⚠ Never apply the high voltage test to the control circuit.

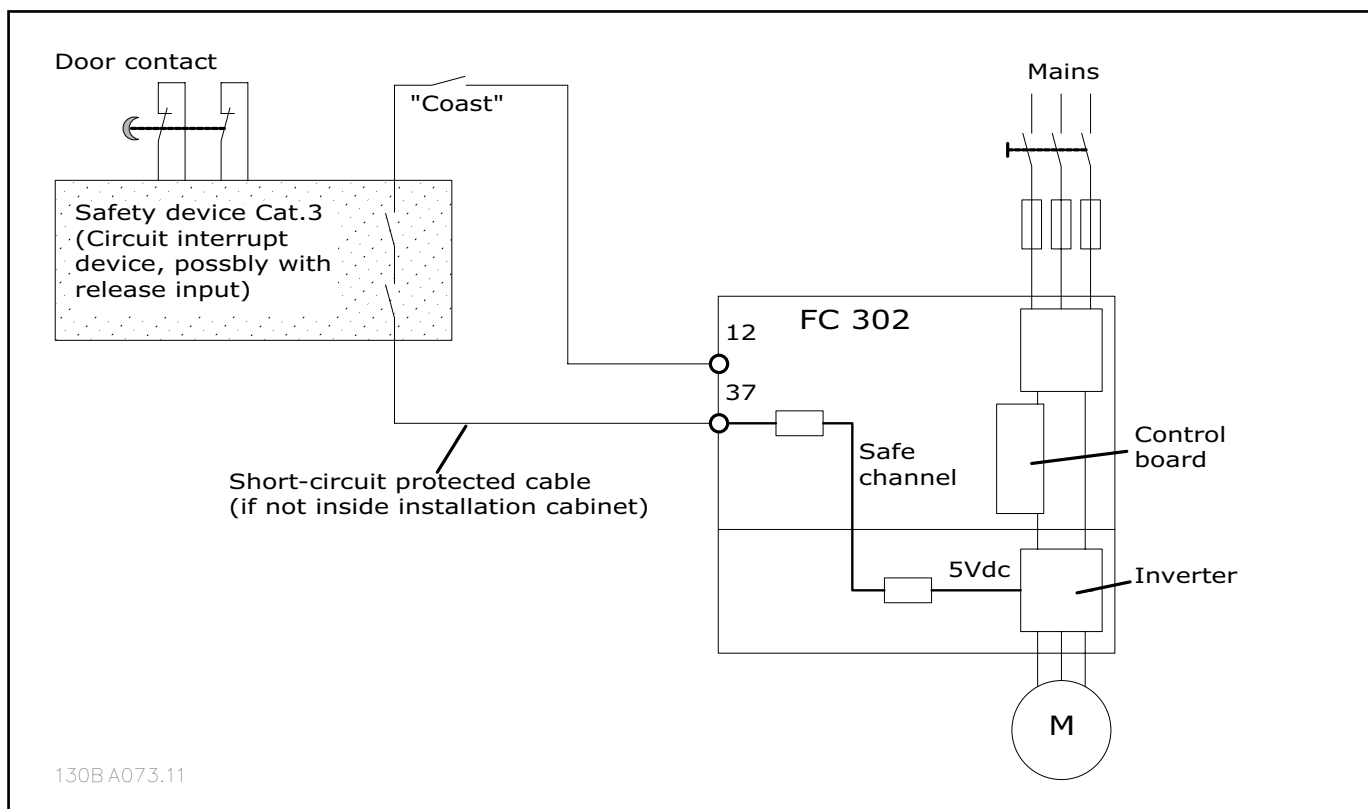

Instructions

Trouble shooting

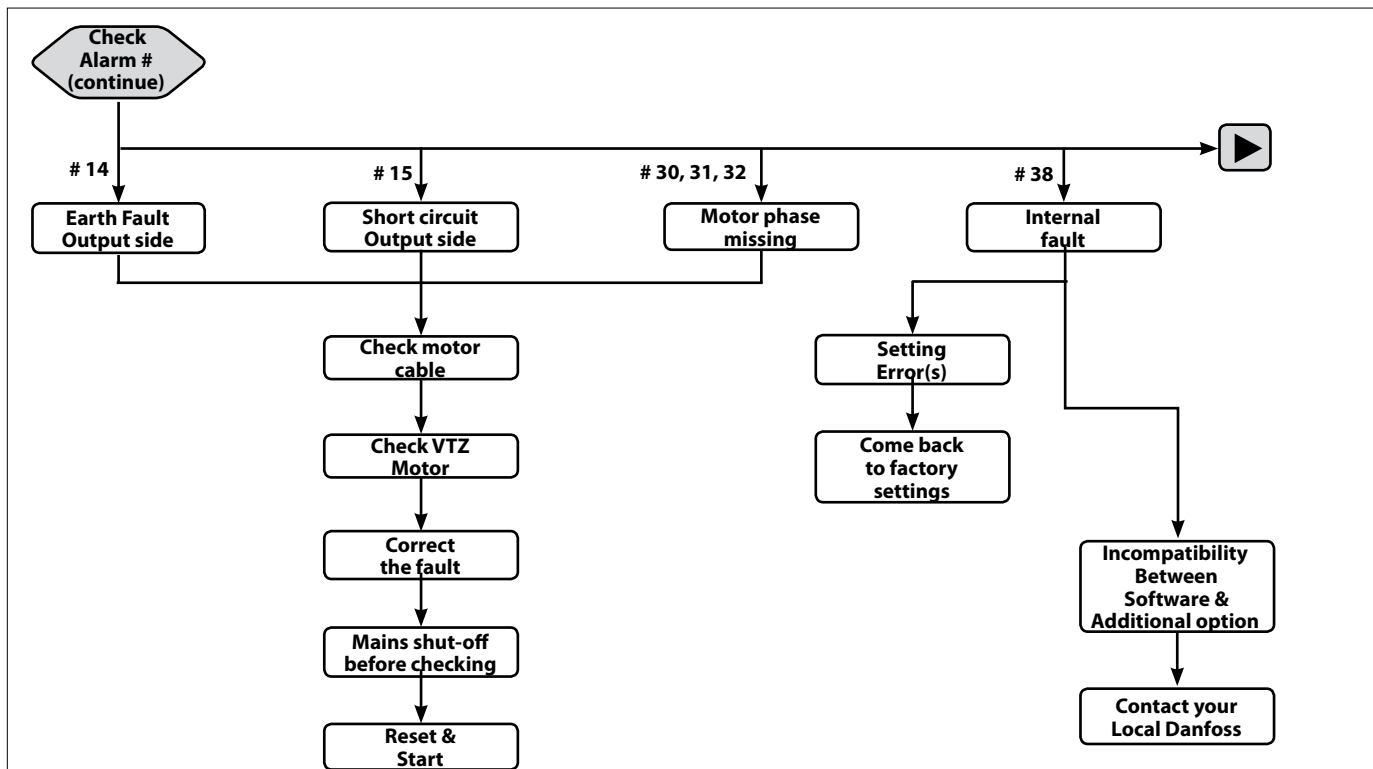
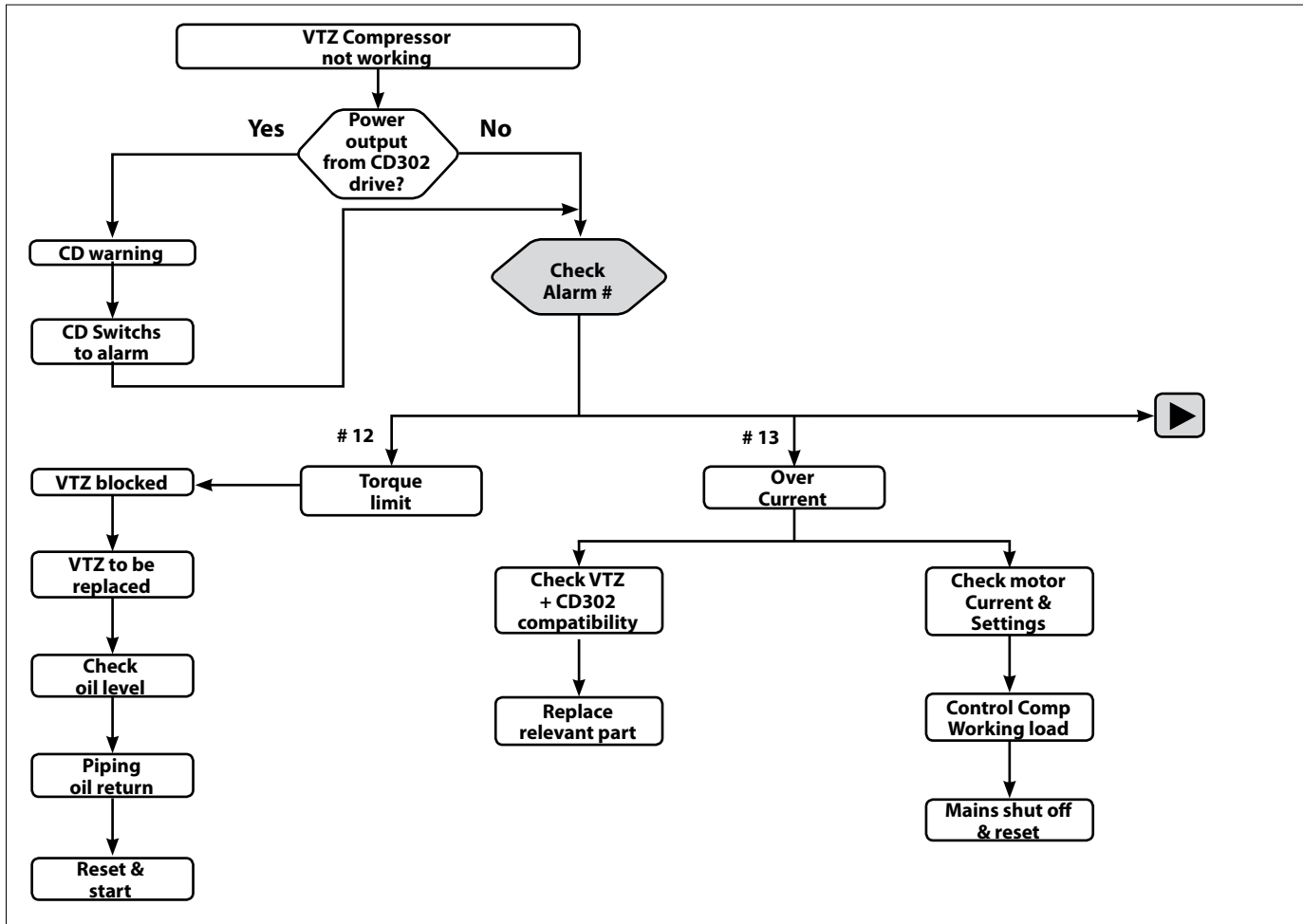

Instructions

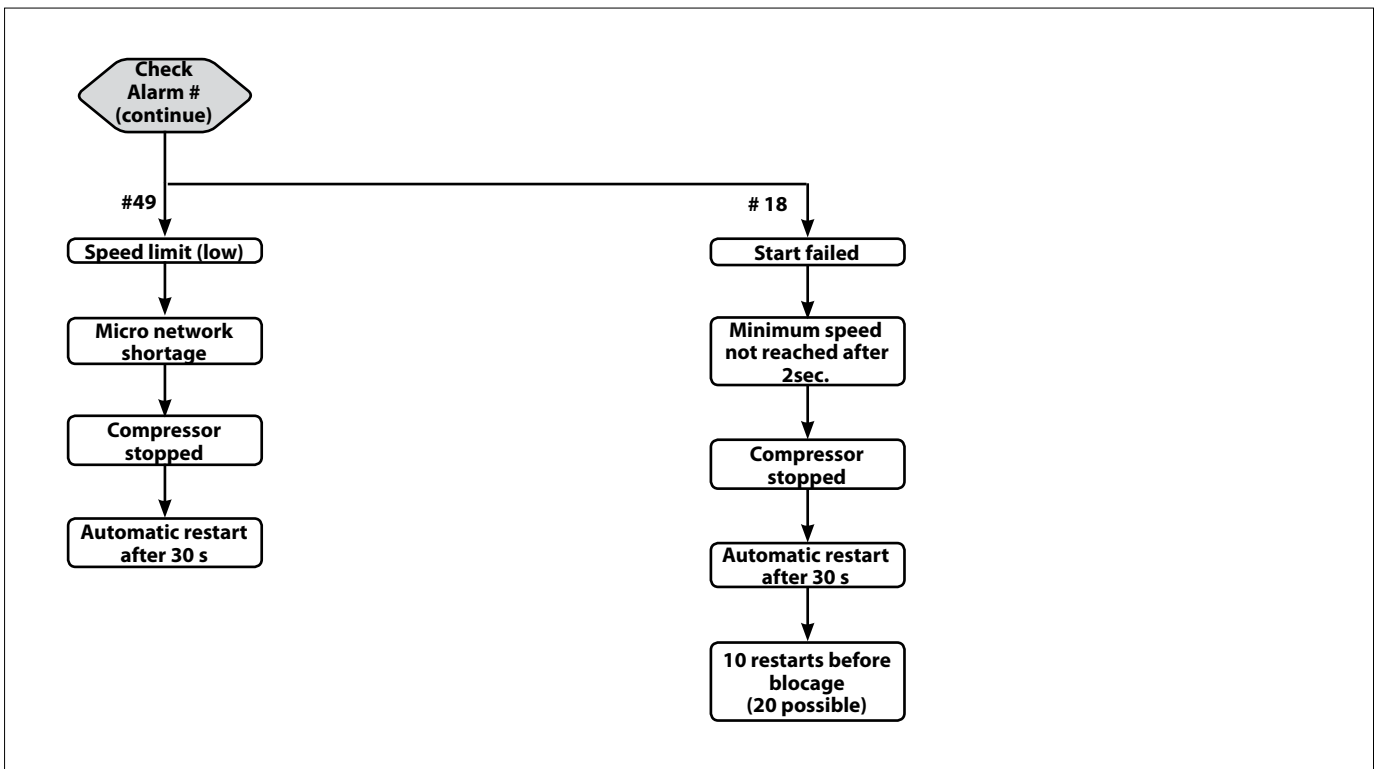
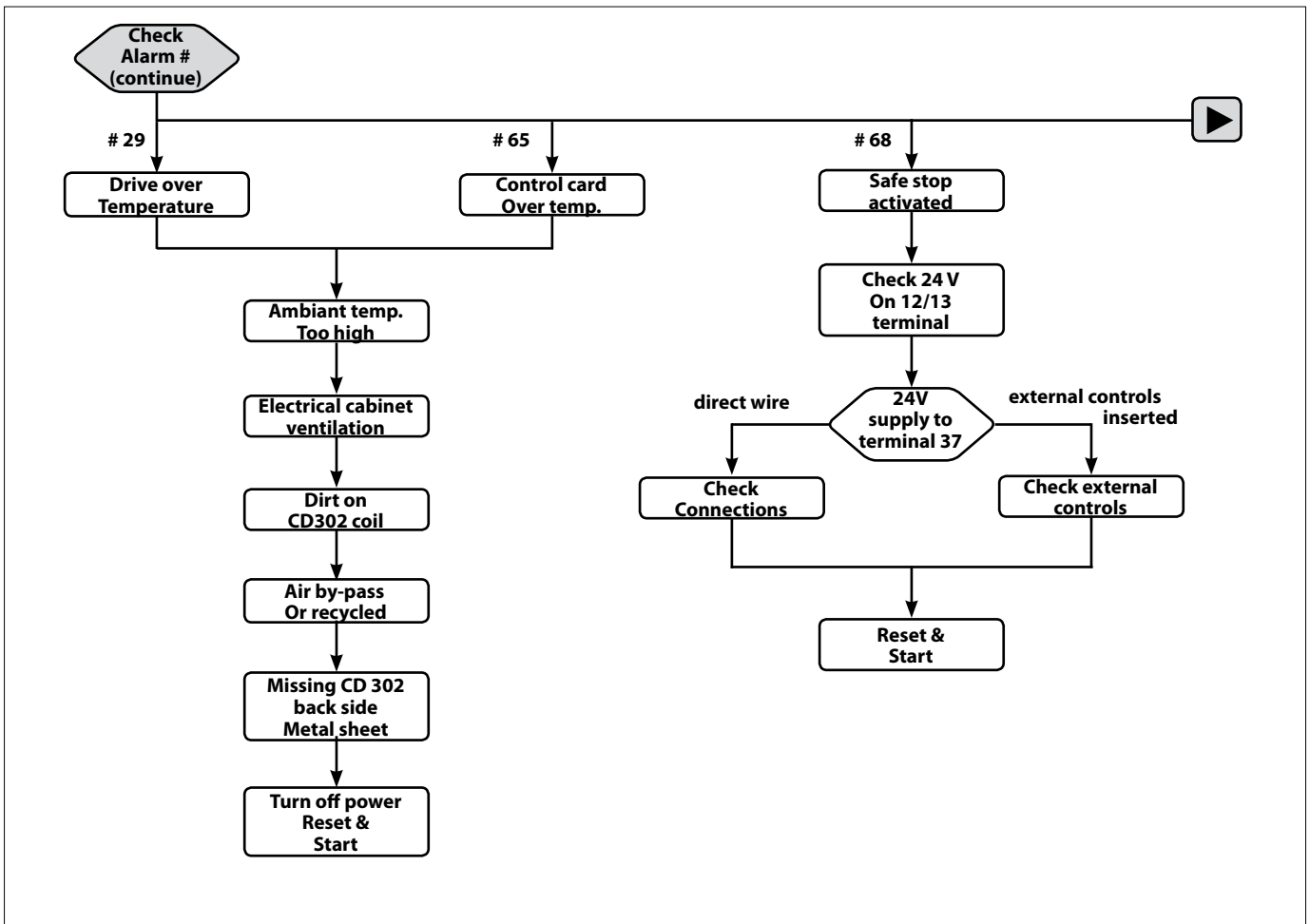

Instructions

How to Program on the Graphical Local

Control Panel

The following instructions are valid for the graphical LCP (LCP 102):

The control panel is divided into four functional groups:

1. Graphical display with Status lines.
2. Menu keys and indicator lights - changing parameters and switching between display functions.
3. Navigation keys and indicator lights (LEDs).
4. Operation keys and indicator lights (LEDs). All data is displayed in a graphical LCP display, which can show up to five items of operating data while displaying [Status].

Display lines

- a. Status line: Status messages displaying icons and graphic.
- b. Line 1-2: Operator data lines displaying data defined or chosen by the user. By pressing the [Status] key, up to one extra line can be added.
- c. Status line: Status messages displaying text. Display Contrast Adjustment
Press [status] and [▼] for darker display
Press [status] and [▲] for brighter display

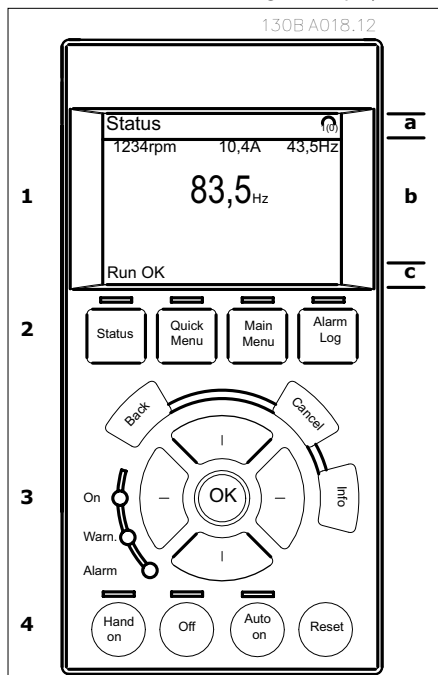

Indicator lights (LEDs)

If certain threshold values are exceeded, the alarm and/or warning LED lights up. A status and alarm text appear on the control panel.

The on LED is activated when the frequency converter receives mains voltage.

. Green LED/On: Control section is working.

. Yellow LED/Warn.: Indicates a warning.

. Flashing Red LED/Alarm: Indicates an alarm.

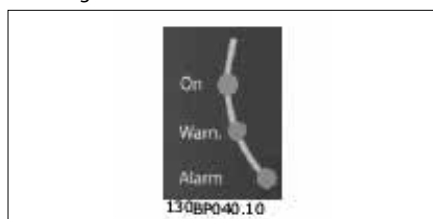

LCP keys

The control keys are divided into functions. The keys below the display and indicator lamps are used for parameter Set-up, including choice of display indication during normal operation.

[Status] indicates the status of the frequency converter and/or the motor compressor. You can choose between 3 different readouts by pressing the [Status] key: 5 line readouts, 4 line readouts or Smart Logic Control by pushing twice the [status] key.

Use [Status] for selecting the mode of display or for changing back to Display mode from either the Quick Menu mode, the Main Menu mode or Alarm mode. Also use the [Status] key to toggle single or double read-out mode.

[Quick Menu] allows quick access to different Quick Menus such as:

- 01 - My Personal Menu
- 02 - Quick Set-up
- 03 - PID Process Loop
- 04 - Changes Made
- 05 - Loggings

Use [Quick Menu] for programming the parameters belonging to the Quick Menu. It is possible to switch directly between Quick Menu mode and Main Menu mode.



Open loop control method

Controls using an external controller with 0-10V signal

No need to change any parameter, this is the factory setting.

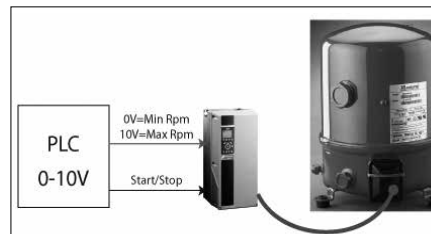

Change switch 53 from U to I.

No need to change any other parameter, this is factory setting.

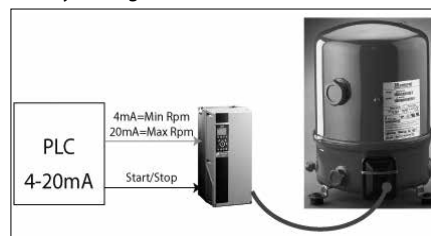

Quick setup

The following lines describe the basic procedure to run the CD302.

1) Connect the power supply to the terminals (L1, L2 and L3) of the CD302 as shown on page 7 of this manual.

2) Connect motor cable between the Drive (U, V & W) and Compressor (Clockwise on terminal), see picture of page 4.

(The connectors utilised in this first 2 steps are provided in the accessory bag which accompanies the CD302)

3) Press "Quick menu" and go to quick setup. Ensure that the correct compressor model is selected in parameter 1-13.

4) Make connections between the terminals 12 and 18 (start signal), connections between terminal 12 and 27 (inverse coast signal) and terminals 12 and 37* (safe stop inverse signal). See pictures on page 9.

* (Please read also on pages 11 and 14 the chapters about Safe Stop)

⚠ When the above connections are made the compressor will start automatically.

⚠ If an error that causes the Drive to trip is detected, it will automatically try to restart the compressor after 30 seconds (unless the error is severe and causes a trip lock). See also parameters 14-20 and 14-21.

Open Loop with external reference

5) Apply analogue speed reference signal (0-10V) on terminal 53 using the terminal 55 as common. The wiring diagram is on page 10 of this manual.

6) Check over if the switch A53 is flicked to U (voltage) instead of I (current). The switch A53 is located on the drive and can be seen when the LCP is removed.

7) **Ready to Run:** If the Drive is supplied with display: Use "Hand on" to set a local speed reference in the display (good for testing purposes). Use "Auto on" for running in operation and with an external reference.

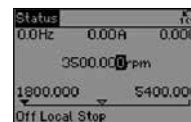

This is how the screen will look like after configuring the drive for **Speed Open loop** application, **Hand On** mode

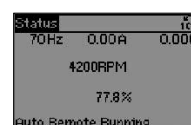

This is how the screen will look like after configuring the drive for Speed Open loop application, Auto On mode

8) Done.

PID closed loop with 4-20 mA pressure transmitter:

9) Connect pressure transmitter to analogue input on terminal 54 according to the schema on page 10.

10) Make sure that the switch for analogue input 54 is set to "I" for current input.

11) Press "Quick Menu" button and go to "PID Closed Loop" menu. Now change parameters to:

• **1-00:** Select: "Process"

• **3-01:** Select: "Bar"

• **3-02 + 3-03:** Enter the lower and upper limits of the set-point range [bar].

• **3-15:** Set to "no function" for fixed set-point.

• **6-22 + 6-23:** The values of these parameters should match the output of the pressure transmitter (4-20 mA for example is the factory setting).

• **6-24 + 6-25:** Set range of pressure transmitter (factory setting -1/+12 bar).

• Go back to **3-13:** Select "Local" to run with a fixed set-point adjustable via keypad. Select "Remote"

Instructions

if the set-point is given by the analogue input.
12) Press "Quick Menu" button, go to "Quick Setup", go to parameter 0-22 and select "Feedback [unit]" ref:[1652]. The pressure [bar] is going to be shown in the upper right corner of the display.



This is how the screen will look like, after configuring the drive for Closed loop application.

13) **Ready to Run:** Press "Hand on" and set reference in bars using the arrows on the display. Before leaving the site never forget the next step.
14) **Ready to Run:** Press "Auto on".

Controls using a 4-20mA process signal & CD302-PID controller

Change switch 54 from U to I
Follow the previous description.

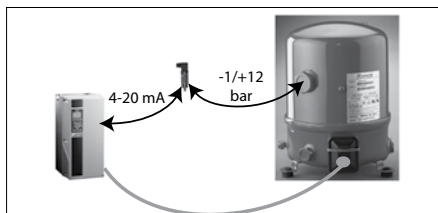

Controls using a 4-20mA process signal & CD302-PID controller + Smart Logic Control

Smart Logic control is preset for:

- Pump-down function
 - Anti-short cycling management
 - Minimum compressor running time control
- Previous Process settings remain the same.

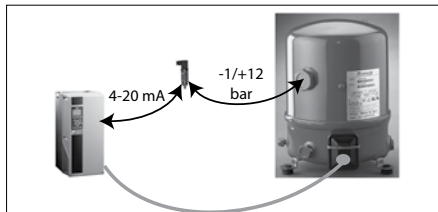

- 15) **Prepare SLC functions:** Press "Off".
16) Press "Quick Menu" button and go to "PID Closed Loop" menu. Now change parameters to:
13-00: Select: "On"
13-12[0]: Cut-in pressure factory set to 1.0 bar; change to your needed value
13-12[1]: Cut-out pressure factory set to 3.0 bar; change to your needed value
13-20[0]: Minimum duration between two starts; factory set to 5 min. (recommended value)
13-12[1]: Minimum compressor running time; factory set to 0 second. Parameter to be adjusted with special care to guarantee a proper oil recovery from the system but the adjustment must avoid the compressor to run under vacuum. 15 to 30 seconds is the recommended adjustment but remaining totally dependent of the system inertia.
17) **Ready to Run:** Press "Auto on".
Note: the same logic can be used for a thermostat function using a thermal sensor instead of a pressure sensor.

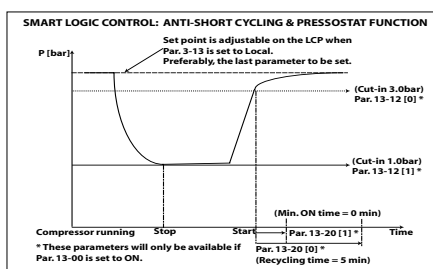

Press [Auto On] to run the CD 302
[Main Menu] is used to access and program all parameters.

It is possible to switch directly between Main Menu mode and Quick Menu mode. Parameter shortcut access can be carried out by pressing down the [Main Menu] key for 3 seconds. The parameter shortcut allows direct access to any parameter.

[Alarm Log] displays an Alarm list of the five latest alarms (numbered A1-A5). To obtain additional details about an alarm, use the arrow keys to manoeuvre to the alarm number and press [OK]. You will now receive information about the condition of your frequency converter right before entering the alarm mode.

[Info] supplies information about a command, parameter, or function in any display window. [Info] provides detailed information whenever help is needed.

Exit info mode by pressing either [Info], [Back], or [Cancel].

Navigation Keys

The four navigation arrows are used to navigate between the different choices available in [Quick Menu], [Main Menu] and [Alarm Log]. Use the keys to move the cursor.

[OK] is used for choosing a parameter marked by the cursor and for enabling the change of a parameter.

Local Control Keys for local control are found at the bottom of the control panel.



[Hand On] enables control of the frequency converter via the LCP. [Hand on] also starts the motor compressor, and it is now possible to enter the motor compressor speed data by means of the arrow keys. The key can be selected as Enable [1] or Disable [0] via par. 0-40 [Hand on] key on LCP.

External stop signals activated by means of control signals or a serial bus will override a .start. command via the LCP.

The following control signals will still be active when [Hand on] is activated:

- [Hand on] - [Off] - [Auto on]
- Reset
- Coasting stop inverse
- Reversing
- Set-up select lsb - Set-up select msb
- Stop command from serial communication
- Quick stop
- DC brake

[Off] stops the connected motor compressor. The key can be selected as Enable [1] or Disable [0] via - par. 0-41 [Off] key on LCP. If no external stop function is selected and the [Off] key is inactive the motor compressor can be stopped by disconnecting the voltage.

[Auto On] enables the frequency converter is to be controlled via the control terminals and/or serial communication. When a start signal is applied on the control terminals and/or the bus, the frequency converter will start. The key can be selected as Enable [1] or Disable [0] via par. 0-42 [Auto on] key on LCP.

NB : An active HAND-OFF-AUTO signal via the digital inputs has higher priority than the control keys [Hand on] . [Auto on].

[Reset] is used for resetting the frequency converter after an alarm (trip). It can be selected as Enable [1] or Disable [0] via par. 0-43 Reset Keys on LCP.

The parameter shortcut can be carried out by holding down the [Main Menu] key for 3 seconds. The parameter shortcut allows direct access to any parameter.

Quick Transfer of Parameter Settings

Once the set-up of a drive is complete, we recommend that you store the data in the LCP or on a PC via MCT 10 Set-up Software Tool.

Data storage in LCP

1. Go to par. 0-50 LCP Copy
 2. Press the [OK] key
 3. Select .All to LCP.
 4. Press the [OK] key
- All parameter settings are now stored in the LCP indicated by the progress bar. When 100% is reached, press [OK].

NB: Stop the motor compressor before performing this operation.

You can now connect the LCP to another frequency converter and copy the parameter settings to this frequency converter as well.

Data transfer from LCP to drive

1. Go to par. 0-50 LCP Copy
 2. Press the [OK] key
 3. Select .All from LCP
 4. Press the [OK] key
- The parameter settings stored in the LCP are now transferred to the drive indicated by the progress bar. When 100% is reached, press [OK].

NB: Stop the motor compressor before performing this operation.

Initialisation to Default Settings

Initialise the frequency converter to default settings in two ways:

Recommended initialisation (via par. 14-22)

1. Select par 14-22
2. Press [OK]
3. Select "Initialisation"
4. Press [OK]
5. Cut Off the mains supply and wait until the display turns off.
6. Reconnect the mains supply - the frequency converter is now reset.

Instructions

Par. 14-22 initialises all except:	
14-50	RFI1
8-30	Protocol
8-31	Address
8-32	Baud Rate
8-35	Minimum Response Delay
8-36	Max Response Delay
8-37	Max Inter-char Delay
15-00 to 15-05	Operating data
15-20 to 15-22	Historic log
15-30 to 15-32	Fault log

Manual initialisation

1. Disconnect from mains and wait until the display turns off.
- 2a. Press [Status] - [Main Menu] - [OK] at the same time while power up for LCP 102, Graphical Display
- 2b. Press [Menu] while power up for LCP 101, Numerical Display
3. Release the keys after 5s.
4. The frequency converter is now programmed according to default settings.

This parameter initialises all except:	
15-00	Operating Hours
15-03	Power-up's
15-04	Over temp's
15-05	Over volt's

Parameter Selection

In the Main menu mode, the parameters are divided into groups. You select a parameter group by means of the navigation keys. The following parameter groups are accessible:

Group n°	Parameter group
0	Operation/Display
1	Load/Motor
2	Brakes
3	Reference/Ramps
4	Limits/Warnings
5	Digital In/Out
6	Analog In/Out
7	Controls
8	Comm. and Options
9	Profibus
10	CAN fieldbus
11	Reserved Com. 1
12	Reserved Com. 2
13	Smart Logic
14	Special functions
15	Drive Information
16	Data Readouts
17	Motor Feedb. Option

After selecting a parameter group, choose a parameter by means of the navigation keys. The middle section on the display shows the parameter number and name as well as the selected parameter value.



Changing Data

The procedure for changing data is the same whether you select a parameter in the Quick menu or the Main menu mode. Press [OK] to change the selected parameter.

The procedure for changing data depends on whether the selected parameter represents a numerical data value or a text value.

Changing a Text Value

If the selected parameter is a text value, change the text value by means of the up/down navigation keys.

The up key increases the value, and the down key decreases the value. Place the cursor on the value you want to save and press [OK].

Changing a Group of Numeric Data Values

If the chosen parameter represents a numeric data value, change the chosen data value by means of the <> navigation keys as well as the up/down navigation keys. Use the <> navigation keys to move the cursor horizontally.

Use the up/down navigation keys to change the data value. The up key enlarges the data value, and the down key reduces the data value. Place the cursor on the value you want to save and press [OK].



Parameter setup modifications

Using quick menu system control modifications can be handled very simply.

Examples:

1) Switch from open loop control 0-10 v input to 4-20 mA.

- Change switch 53 from U to I

2) Change from Open Loop factory set to Process Loop.

- Select [Quick Menu]
- Select Q3 – PID Closed Loop
- Par: 1-00 change to [3] « Process »
- Par: 3-01 change to [71] « bar »
- Par 3-02 enter pressure sensor low range value (factory set at -1 bar)
- Par 3-02 enter pressure sensor high range value (factory set at 12 bar)
- Par 3-10 enter suction pressure adjustment required as a percentage of the sensor pressure range (28% for 3.4 bar → -10°C R404A)
- Par 3-13 Select which reference site to activate. Select **Linked to Hand / Auto [0]** to use the local reference when in Hand mode; or the remote reference when in Auto mode (factory default).

Select **Remote [1]** to use the remote reference in both Hand mode and Auto mode.

Select **Local [2]** to use the local reference in both Hand mode and Auto mode.

- Par 3-15 Change from Analog input 53 to [0] "No Function"
- Par 6-24 Preset to -1 bar
- Par 6-25 Preset to 12 bar
- Par 7-20 Preset to analog input 54 (Analog input for PID control)

- Par 7-33 Process PID Proportionnal gain factory set to 2

- Par 7-34 Process PID Integral time factor set to 9 s, to be modified in regards to the system inertia.

- Par 13-** are related to smart logic control. On process control operation this function is activated by setting 13.00 to "ON".

o Two main controls are handled then automatically by the CD Compressor Drive:

- o 1) compressor working duration avoiding short cycling and handling oil return from the refrigeration system to the compressor.

- . Par 13-20-0 Minimum time between two starts is factory set at 5 minutes.

- . Par 13-20-1 Minimum running time is factory set at 0 and has to be adjusted regarding the system design to avoid tripping on low pressure.

- o 2) Pump down function that manages the compressor On/Off cycle in regards to preset low pressure values.

- . Par 13-12-0 Low pressure cut-in value.

- . Par 13-12-1 Low pressure cut-out value

Parameters: Operation and Display

* Always shows the factory set value

0-0* Basic Settings

Parameter group for basic frequency converter settings.

0-01 Language

Option:

- *English (ENGLISH) [0]
- German (DEUTSCH) [1]
- French (FRANCAIS) [2]
- Danish (DANSK) [3]
- Spanish (ESPAÑOL) [4]
- Italian (ITALIANO) [5]

Defines the language to be used in display.

0-02 Motor Speed Unit

Option:

- *RPM [0]
 - Hz [1]
- Select display of motor speed parameters (i.e. references, feedbacks and limits) in terms of shaft speed (RPM) or output frequency to the motor (Hz). This parameter cannot be adjusted while the motor is running.

0-2* LCP Display

Define the display in the Graphical Logic Control Panel.

0-20 Display Line 1.1 Small

- None [0]
- Warning Parameter [1013]
- Running Hours [1501]
- kWh Counter [1502]
- Reference [Unit] [1601]
- Reference % [1602]
- Status Word [1603]
- Power [kW] [1610]
- Power [hp] [1611]
- Motor Voltage [1612]
- Frequency [1613]
- Motor Current [1614]
- Frequency [%] [1615]
- Torque [1616]
- * Speed [RPM] [1617]
- DC Link Voltage [1630]
- Heatsink Temp. [1634]
- Inverter Thermal [1635]

Instructions

Inv. Nom. Current	[1636]
Inv. Max. Current	[1637]
SL Control State.....	[1638]
Control Card Temp	[1639]
External Reference	[1650]
Feedback [Unit]	[1652]
Digital Input	[1660]
Terminal 53 Switch Setting	[1661]
Analog Input 53	[1662]
Terminal 54 Switch Setting	[1663]
Analog Input 54	[1664]
Analog Output 42 [mA]	[1665]
Freq. Input #29 [Hz]	[1667]
Freq. Input #33 [Hz]	[1668]
Pulse Output #27 [Hz].....	[1669]
Pulse Output #29 [Hz].....	[1670]
Relay Output [bin].....	[1671]
Counter A	[1672]
Counter B.....	[1673]
Digital Inputs.....	[3440]
Digital Outputs	[3441]

Select a variable for display in line 1, left position.

0-21 Display Line 1.2 Small

*Motor Current [A]	[1614]
--------------------------	--------

Options are the same as in par. 0-20

0-22 Display Line 1.3 Small

*Power [kW].....	[1610]
------------------	--------

Options are the same as in par. 0-20.

0-23 Display Line 2 Large

*Frequency [Hz]	[1613]
-----------------------	--------

Options are the same as in par. 0-20.

0-24 Display Line 3 Large

* Analog Input 53	[1662]
-------------------------	--------

Options are the same as in par. 0-20.

0-25 My Personal Menu

Define up to 20 parameters to include in the Q1 Personal Menu, accessible via the [Quick Menu] key on the LCP. The parameters will be displayed in the Q1 Personal Menu in the order they are programmed into this array parameter. Delete parameters by setting the value to « 0000 ».

0-4* LCP Keypad

Enable and disable individual keys on the LCP keypad.

0-40 [Hand on] Key on LCP

Option:	
Disabled.....	[0]
*Enabled.....	[1]
Password.....	[2]

Function:

Select *Disabled* [0] to avoid accidental start of the frequency converter in Hand mode. Select *Password* [2] to avoid unauthorised start in Hand mode. If par. 0-40 is included in the Quick Menu, then define the password in par. 0-65 *Quick Menu Password*.

0-41 [Off] Key on LCP

Options are the same as in par. 0-40.

0-42 [Auto on] Key on LCP

Options are the same as in par. 0-40.

0-43 [Reset] Key on LCP

Options are the same as in par. 0-40.

0-5* Copy / Save

Copy parameter settings between set-ups and to/from the LCP.

0-50 LCP Copy

Option:

*No copy	[0]
All to LCP	[1]
All from LCP	[2]
Size indep. from LCP	[3]

Function:

Select *Transfer to LCP all parameters* [1] to copy all parameters in all set-ups from the frequency converter memory to the LCP memory.

Select *Transfer from LCP all parameters* [2] to copy all parameters in all set-ups from the LCP memory to the frequency converter memory.

Select *Transfer from LCP size indep. parameters* [3] to copy only the parameters that are independent of the motor size.

0-51 Set-up Copy

Option:

*No copy	[0]
Copy to set-up 1	[1]
Copy to set-up 2	[2]
Copy to set-up 3	[3]
Copy to set-up 4	[4]
Copy to all	[9]

Function:

Select *Copy to set-up 1* [1] to copy all parameters in the present edit set-up (defined in par. 0-11 *Edit Set-up*) to Set-up 1. Likewise, select the option corresponding to the other set-up(s).

Select *Copy to all* [9] to copy the parameters in the present set-up over to each of the set-ups 1 to 4.

0-6* Password

Define password access to menus.

0-60 Main Menu Password

Function:

Define the password for access to the Main Menu via the [Main Menu] key. If par. 0-61 *Access to Main Menu w/o Password* is set to Full access [0], this parameter will be ignored.

0-61 Access to Main Menu w/o Password

Option:

*Full access	[0]
Read only.....	[1]
No access.....	[2]

Function:

Select *Full access* [0] to disable the password defined in par. 0-60 *Main Menu Password*. Select *Read only* [1] to prevent unauthorised editing of Main Menu parameters. Select *No access* [2] to prevent unauthorised viewing and editing of Main Menu parameters. If *Full access* [0] is selected then parameters 0-60, 0-65 and 0-66 will be ignored.

0-65 Quick Menu Password

Function:

Define the password for access to the Quick Menu via the [Quick Menu] key. If par. 0-66 *Access to Quick Menu w/o Password* is set to *Full access* [0], this parameter will be ignored.

0-66 Access to Quick Menu w/o Password

Option:

*Full access	[0]
Read only	[1]
No access.....	[2]

Function:

Select *Full access* [0] to disable the password defined in par. 0-65 *Quick Menu Password*. Select *Read only* [1] to prevent unauthorised editing of Quick Menu parameters.

Select *No access* [2] to prevent authorised viewing and editing of Quick Menu parameters. If par. 0-61 *Access to Main Menu w/o Password* is set to Full access [0] then this parameter will be ignored.

Parameters: Load and Motor

1-0* General Settings

Define whether the frequency converter operates in speed mode or torque mode; and whether the internal PID control should be active or not.

All parameters from 1-01 (included) to 1-81 (included) are read only. Just the 1-13 remain accessible for compressor selection.

1-00 Configuration Mode

Option:

*Speed open loop	[0]
Process	[3]

Function:

Select the application control principle to be used when a Remote Reference (via analog input) is active. A Remote Reference can only be active when par. 3-13 *Reference Site* is set to [0] or [1].

Speed open loop [0]: Enables speed control (without feedback signal from motor) for almost constant speed at varying loads.

Process [3]: Enables the use of process control in the frequency converter. The process control parameters are set in par. groups 7-2* and 7-3*.

This parameter cannot be adjusted while the motor is running.

1-01 Motor Control Principle

VVCplus.....	[1]
Flux sensorless	[2]

Motor compressor dependant cannot be modified.

1-03 Torque Characteristics

Motor compressor dependant, cannot be modified.

1-04 Overload Mode

Motor compressor dependant, cannot be modified.

1-05 Local Mode Configuration

Cannot be modified, as Config Mode P1-00.

1-10 Motor Construction

Motor compressor dependant, cannot be modified (Asynchronous).

1-13 Compressor selection

Allows compressor/refrigerant set selection

1-2* Motor Data

Parameter group 1-2* comprises input data for the relevant compressor selected in Par. 1-13. These parameters cannot be modified from the CD302 data-base.

1-20.....	Motor Power [kW]
1-21.....	Motor Power [HP]
1-22.....	Motor Voltage
1-23.....	Motor Frequency
1-24.....	Motor Current
1-25.....	Motor Nominal Speed

1-3* Adv. Motor Data

Parameter group 1-2* comprises input data for the relevant compressor selected in Par. 1-13. These parameters cannot be modified from the CD302 data-base.

1-30.....	Stator Resistance (Rs)
1-31	Rotor Resistance (Rr)
1-33	Stator Leakage Reactance (X1)
1-34	Rotor Leakage Reactance (X2)
1-35.....	Main Reactance (Xh)

Instructions

1-36..... Iron Loss Resistance (Rfe)
1-39 Motor Poles

1-6* Load Depend. Setting

Parameters for adjusting the load-dependent motor settings.

1-62..... Slip Compensation
1-66..... Min. Current at Low Speed
1-68..... Minimum Inertia
1-69..... Maximum Inertia

1-7* Start Adjustments

Parameters for setting special motor start features.

1-71..... Start Delay
1-72..... Start Function
1-73..... Flying Start [RPM]
1-74..... Start Speed [RPM]
1-75..... Start Speed [Hz]
1-76..... Start Current
1-77..... High starting torque Max speed [RPM]

1-8* Stop Adjustments

Parameters for setting special stop features for the motor.

1-80..... Function at Stop
1-81..... Min Speed Stop function [RPM]

1-9* Motor Temperature

1-90 Motor Thermal Protection

Option:

*No protection [0]
Thermistor warning [1]
Thermistor trip [2]
ETR warning 1 [3]

The frequency converter determines the motor temperature for motor protection in two different ways:

. Via a thermistor sensor connected to one of the analog or digital inputs (par. 1-93 Thermistor Source).

. Via calculation (ETR = Electronic Terminal Relay) of the thermal load, based on the actual load and time. The calculated thermal load is compared with the rated motor current IM,N and the rated motor frequency fM,N. The calculations estimate the need for a lower load at lower speed due to less cooling from the fan incorporated in the motor.

1-91 Motor External Fan

Option:

*No [0]
Yes [1]

Function:

Select *No* [0] if no external fan is required, i.e. the motor is derated at low speed.
Select *Yes* [1] to apply an external motor fan (external ventilation)

1-93 Thermistor Source

Option:

*None [0]
Analog input 53 [1]
Analog input 54 [2]
Digital input 18 [3]
Digital input 19 [4]
Digital input 32 [5]
Digital input 33 [6]

Function:

Select the input to which the thermistor (PTC sensor) should be connected. An analog input option [1] or [2] cannot be selected if the analog input is already in use as a reference source (selected in par. 3-15 Reference Source 1, 3-16 Reference Source 2 or 3-17 Reference Source 3).

This parameter cannot be adjusted while the motor is running.

Parameters: Reference/Ramps

Parameters for reference handling, definition of limitations, and configuration of the reaction of the frequency converter to changes.

3-0* Reference Limits

Parameters for setting the reference unit, limits and ranges.

3-00 Reference Range

Option:

*Min. - Max [0]
-Max - +Max [1]

Function:

Select the range of the reference signal and the feedback signal. Signal values can be positive only, or positive and negative. The minimum limit may have a negative value, unless *Speed closed loop* [1] control is selected in par. 1-00 Configuration Mode.

Select *Min. - Max* [0] for positive values only.

Select *-Max - +Max* [1] for both positive and negative values.

3-01 Reference/Feedback Unit

None [0]
*bar [71]
°C [60]
°F [160]
psi [170]

Function:

Select the unit to be used in Process PID Control references and feedbacks.

3-02 Minimum Reference

Function:

Enter the Minimum Reference. The Minimum Reference is the lowest value obtainable by summing all references.

Minimum Reference is active only when par. 3-00 Reference Range is set to Min.- Max. [0].

The Minimum Reference unit matches

- the choice of configuration in par 1-00 Configuration Mode: for *Speed closed loop* [1].
- the unit selected in par. 3-01 Reference/Feedback Unit.

3-03 Maximum Reference

Enter the Maximum Reference.

3-10 Preset Reference

Array [8]

Range:

-100.00 - 100.00 % *0.00%

Function:

Must remain 0 for Open Loop Control

The preset reference is stated as a percentage of the value RefMAX (par. 3-03 *Maximum Reference*) or as a percentage of the other external references. If a RefMIN 0 (Par. 3-02 *Minimum Reference*) is programmed, the preset reference is calculated as a percentage of the full reference range, i.e. on the basis of the difference between RefMAX and RefMIN. Afterwards, the value is added to RefMIN. When using preset references, select Preset ref. bit 0 / 1 / 2 [16], [17] or [18] for the corresponding digital inputs in parameter group 5.1* Digital Inputs.

3-13 Reference Site

Option:

*Linked to Hand / Auto [0]
Remote [1]

Local [2]

Function:

Select which reference site to activate.

Select *Linked to Hand / Auto* [0] to use the local reference when in Hand mode; or the remote reference when in Auto mode.

Select *Remote* [1] to use the remote reference in both Hand mode and Auto mode.

Select *Local* [2] to use the local reference in both Hand mode and Auto mode.

3-14 Preset Relative Reference

Range:

-100.00 - 100.00 % * 0.00%

Function:

Define a fixed value (in %) to be added to the variable value (defined in par. 3-18 Relative Scaling Reference Source). The sum of the fixed and variable values is multiplied with the actual reference (labelled X in the illustration below). This product is then added to the actual reference (X+X*Y/100) to give the resultant actual reference.

3-15 Reference Resource 1

Option:

No function [0]
*Analog input 53 [1]
Analog input 54 [2]
Frequency input 29 [7]
Frequency input 33 [8]
Local bus reference [11]
Digital pot.meter [20]

Function:

Select the reference input to be used for the first reference signal. Par. 3-15, 3-16 and 3-17 define up to three different reference signals. The sum of these reference signals defines the actual reference. This parameter cannot be adjusted while the motor is running.

3-16 Reference Resource 2

Option: Id. 3-15

*No function [0]

Function:

Select the reference input to be used for the second reference signal. Par. 3-15, 3-16 and 3-17 define up to three different reference signals. The sum of these reference signals defines the actual reference.

This parameter cannot be adjusted while the motor is running.

3-17 Reference Resource 3

Option: Id. 3-15

*No function [0]

Function:

Select the reference input to be used for the third reference signal. Par. 3-15, 3-16 and 3-17 define up to three different reference signals. The sum of these reference signals defines the actual reference.

This parameter cannot be adjusted while the motor is running.

3-18 Relative Scaling Reference Resource

Option: Id. 3-15

*No function [0]

Select a variable value to be added to the fixed value (defined in par. 3-14 Preset Relative Reference). The sum of the fixed and variable values is multiplied with the actual reference labelled X in the illustration below). This product is then added to the actual reference (X+X*Y/100) to give the resultant actual reference.

Instructions

3-40 Ramp 1 Type

Option:

*Linear [0]

Function:

Select the ramp type, depending on requirements for acceleration/deceleration. A linear ramp will give constant acceleration during ramping.

3-41 Ramp up time running (sec)

Range:

0.01 - 3600.00 s * 9.00s

Function:

Enter the ramp-up time, i.e. the acceleration time to reach the system required motor speed.

3-42 Ramp Down Time running (sec)

Range:

0.01 - 3600.00 s * 0.30s

Function:

Enter the ramp-down time, i.e. the deceleration time to reach compressor minimum motor speed.

3-82 Starting Ramp-up Time

Compressor dependent, factory set : read only

Parameters: Limits/Warnings

Parameter group for configuring limits and warnings.

4-1* Motor Limits

4-10 Motor Speed Direction

*Clockwise [0]

Because previous settings rotation is always clockwise (positive), but be sure that CD302 U, V, W terminals are connected to the correspondent compressor motor terminals.

4-11 Motor Speed Low Limit [RPM]

Compressor dependent, factory set : read only

4-12 Motor Speed Low Limit [Hz]

Compressor dependent, factory set : read only

4-13 Motor Speed High Limit [RPM]

Compressor dependent, factory set : read only

4-14 Motor Speed High Limit [Hz]

Compressor dependent, factory set : read only

4-16 Torque Limit Motor Mode

Compressor dependent, factory set : read only

4-18 Current Limit

Range:

0.0 - Variable Limit % Set to UL MMT

Value:

The current can be adjusted in regards to the compressor operation.

4-19 Max Output Frequency

Compressor dependent, factory set : read only

4-5* Adj. Warnings

Adjustable warning limits for current, speed, reference and feedback. Warnings are shown on display, programmed output or serial bus.

4-51 Warning Current High

* As par. 1-24 Compressor dependent, factory set : read only

Function:

When the motor current exceeds this limit (IHIGH), the display reads CURRENT HIGH. Then the CD302

frequency converter adjusts automatically the motor compressor speed in order to reduce the load and control the current value below the limit.

4-52 Warning Speed Low

* As par. 4-11 Compressor dependent, factory set : read only

When motor compressor speed reach this value or less during a period of time of two seconds then the compressor is stopped by the CD302 frequency converter and automatically restart after a delay set in Par. 14-21

4-53 Warning Speed High

* As par. 4-13 Compressor dependent, factory set : read only

4-58 Missing Motor Phase Function

Option:

Off [0]

*On [1]

Function:

Select *On*, to display an alarm in the event of a missing motor phase. Select *Off*, for no alarm in the event of a missing motor phase. However, if the motor runs on only two phases, it can be damaged by overheating. Retaining the *On* setting is therefore strongly recommended. This parameter cannot be adjusted while the motor is running.

Parameters: Digital In/Out

Parameter group for configuring the digital input and output.

5-0* Digital In/Out Mode

5-00 Digital In/Out Mode

Option:

*PNP [0]

NPN [1]

Function:

Digital inputs and programmed digital outputs are pre-programmable for operation either in PNP or NPN systems.

Select *PNP [0]* systems for action on positive directional pulses ().

5-01 Terminal 27 Mode

Option:

*Input [0]

Output [1]

Function:

Select *Input [0]* to define terminal 27 as a digital input.

Select *Output [1]* to define terminal 27 as a digital output.

This parameter cannot be adjusted while the motor is running.

5-02 Terminal 29 Mode

Similar to Terminal 27

5-1* Digital Inputs

Parameters for configuring the input functions for the input terminals.

The digital inputs are used for selecting various functions in the frequency converter.

5-10 Terminal 18 Digital Input

Function:

Start [8]

5-11 Terminal 19 Digital Input

Function:

No operation [0]

5-12 Terminal 27 Digital Input

Function:

Coast inverse [2]

5-13 Terminal 29 Digital Input

Function:

No operation [0]

5-14 Terminal 32 Digital Input

Function:

No operation [0]

5-15 Terminal 33 Digital Input

Function:

No operation [0]

Parameters: Analog In/Out

Parameter group for configuration of the analog input and output.

6-0* Analog In/Out Mode

Parameter group for setting up the analog In/Out configuration.

CD 302 is equipped with 2 analog inputs: Terminal 53 and 54. The analog inputs on CD 302 can freely be allocated to either voltage (-10 V - +10 V) or current input (0/4 - 20 mA).

6-1* Analog Input 1

Parameters for configuring the scaling and limits for analog input 1 (terminal 53). Note: that Analog input 53 is preset for usage with "opent loop" control on 0-10 Volt. Terminal 54 is preset for "Process Loop" control using a pressure sensor AKS with a pessure range of -1 : 12 bar.

6-10 Terminal 53 Low Voltage

Range:

-10.0 - par. 6-11 * 0.00V

This analog input scaling value should correspond to the minimum reference value, set in par. 3-02.

6-11 Terminal 53 High Voltage

Range:

6-10 to 10V * 10.00V

This analog input scaling value should correspond to the maximum reference value, set in par. 3-03.

6-12 Terminal 53 Low Current

Range:

0.0 to par. 6-13 mA * 4.0mA

This reference signal should correspond to the minimum reference value, set in par. 3-02.

6-13 Terminal 53 High Current

Range:

6-12 to 20 mA * 20.0mA

This reference signal should correspond to the maximum reference value, set in par. 3-02.

6-14 Terminal 53 Low Ref./Feedb. Value

As Par. 3-02 but not linked

6-15 Terminal 53 High Ref./Feedb. Value

As Par. 3-03 but not linked

Instructions

6-20 Terminal 54 Low Voltage

Range:
-10.0 - par. 6-11 * 1.00V
This analog input scaling value should correspond to the minimum output value of the pressure sensor

6-21 Terminal 54 High Voltage

Range:
6-10 to 10 V * 5.00V
This analog input scaling value should correspond to the maximum output value of the pressure sensor.

6-22 Terminal 54 Low Current

Range:
0.0 to par. 6-13 mA * 4.0mA
This reference signal should correspond to the minimum output value of the pressure sensor.

6-23 Terminal 54 High Current

Range:
6-12 to 20 mA * 20.0mA
This reference signal should correspond to the maximum output value of the pressure sensor.

6-24 Terminal 54 Low Ref./Feedb.

Value -1 (bar)

6-55 Terminal 54 High Ref./Feedb.

Value 12 (bar)

Parameters: Controllers

7-0* Speed PID Ctrl.

Parameters for configuring the speed PID control. Parameters fully dedicated to the internal speed control : Read only.

7-00 Speed PID Feedback Source

Option:
*Motor feedb. p.1-02 [0]

7-02 Speed PID ProportionalGain

Compressor dependent, factory set : read only

7-03 Speed PID Integral Time

Compressor dependent, factory set : read only

7-04 Speed PID Differentiation Time

Compressor dependent, factory set : read only

7-05 Speed PID Diff Gain Limit

Compressor dependent, factory set : read only

7-2* Process Ctrl. Feedb.

Select the feedback sources for the Process PID Control, and how this feedback should be handled.

7-20 Process CL Feedback 1 Resource

No function [0]
Analog input 53 [1]
*Analog input 54 [2]
Frequency input 29 (FC 302 only) [3]
Frequency input 33 [4]
For process loop with current input, 54 switch has to be positioned on I (current).

7-30 Process PID Normal/ Inverse Control

Option:
Normal [0]

*Inverse [1]
Inverse action has to be selected for a process loop using a suction pressure sensor to control the system.

7-31 Process PID Anti Windup

Option:
Off [0]
*On [1]

Function:

Select *Off* [0] to cease regulation of an error when the output frequency can no longer be adjusted. Select *On* [1] to continue regulation of an error even when the output frequency cannot be increased or decreased.

7-32 Process PID Start Speed

Set point 3000 [RPM]

Function:

Enter the motor speed to be attained as a start signal for commencement of PID control. When the power is switched on, the frequency converter will commence ramping and then operate under speed open loop control. Thereafter, when the Process PID start speed is reached, the frequency converter will change over to Process PID control.

7-33 Process PID Proportional Gain

Range:
0.00 - 10.00 N/A *2.00N/A

Function:

Enter the PID proportional gain. The proportional gain multiplies the error between the set point and the feedback signal.

7-34 Process PID Integral Time

Range:
0.01 - 10000.00 *9.00s

Function:

Enter the PID integral time. The integrator provides an increasing gain at a constant error between the set point and the feedback signal. The integral time is the time needed by the integrator to reach the same gain as the proportional gain.

7-35 Process PID Differentiation Time

Range:
0.00 - 10.00 s *0.00s

Function:

Enter the PID differentiation time. The differentiator does not react to a constant error, but provides a gain only when the error changes. The shorter the PID differentiation time, the stronger the gain from the differentiator.

Note: This PID parameters are comfortable to start any system, but depending on its design they have to be adjusted to follow the inertia and all responses of the the real refrigeration machine.

Parameters: Special Functions

Parameter group for configuring special frequency converter functions.

14-0* Inverter Switching

Parameters for configuring the inverter switching.

14-01 Switching Frequency

3.5 kHz [5]

14-03 Overmodulation

Option:
Off [0]

*On [1]

Function:

Select *On* [1] to connect the overmodulation function for the output voltage, to obtain an output voltage up to 15% greater than the mains voltage. Select *Off* [0] for no overmodulation of the output voltage, in order to avoid torque ripple on the motor shaft. This feature may be useful for applications such as grinding machines.

14-1* Mains On/Off

Parameters for configuring mains failure monitoring and handling.

14-12 Function at Mains Imbalance

Option:

Trip [0]
*Warning [1]
Disabled [2]

Function:

When a severe mains imbalance is detected:

- Select *Trip* [0] to trip the frequency converter;
- Select *Warning* [1] to issue a warning; or
- Select *Disabled* [2] for no action.

Operation under severe main imbalance conditions reduces the lifetime of the motor. Conditions are considered severe if the motor is operated continuously near nominal load.

14-2* Trip Reset

Parameters for configuring auto reset handling, special trip handling and control card self test or initialisation.

14-20 Reset Mode

Automatic reset x 10 [10]

Function:

Select the reset function after tripping. Once reset, the frequency converter can be restarted. Select *Manual reset* [0], to perform a reset via [RESET] or via the digital inputs. Select *Automatic reset x 1.x20* [1]-[12] to perform between one and twenty automatic resets after tripping.

NB: If the specified number of AUTOMATIC RESETs is reached within 10 minutes, the frequency converter enters *Manual reset* [0] mode. After the *Manual reset* is performed, the setting of par. 14-20 reverts to the original selection. If the number of AUTOMATIC RESETs is not reached within 10 minutes, or when a *Manual reset* is performed, the internal AUTOMATIC RESET counter returns to zero. The motor may start without warning.

14-21 Automatic Restart Time

Range:
0 - 600 s *30s

Function:

Enter the time interval from trip to start of the automatic reset function. This parameter is active when par. 14-20 is set to *Automatic reset*.

14-22 Operation Mode

Option:

*Normal operation [0]
Control card test [1]
Initialisation [2]

Function:

Use this parameter to specify normal operation; to perform tests; or to initialise all parameters except par. 15-03, 15-04 and 15-05. This function is active only

Instructions

when the power is cycled to the frequency converter. Select *Normal operation* [0] for normal operation of the frequency converter with the motor in the selected application.

Select *Control card test* [1] to test the analog and digital inputs and outputs and the +10 V control voltage. The test requires a test connector with internal connections. Use the following procedure for the control card test:

1. Select *Control card test* [1].
2. Disconnect the mains supply and wait for the light in the display to go out.
3. Set switches S201 (A53) and S202 (A54) = ON. / I.
4. Insert the test plug (see below).
5. Connect to mains supply.
6. Carry out various tests.
7. The results are displayed on the LCP and the frequency converter moves into an infinite loop.
8. Par. 14-22 is automatically set to Normal operation. Carry out a power cycle to start up in Normal operation after a control card test.

If the test is OK:

LCP read-out: Control Card OK. Disconnect the mains supply and remove the test plug. The green LED on the Control Card will light up.

If the test fails:

LCP read-out: Control Card I/O failure.

Replace the frequency converter or Control card.

The red LED on the Control Card is turned on.

Test plugs (connect the following terminals to each other): 18 - 27 - 32; 19 - 29 - 33; 42 - 53 - 54

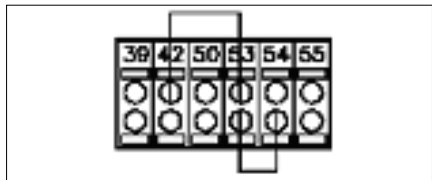
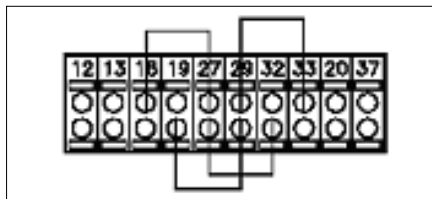

Select *Initialization* [2] to reset all parameter values to default settings, except for par. 15-03, 15-

04, and 15-05. The frequency converter will reset during the next power-up.

Par. 14-22 will also revert to the default setting *Normal operation* [0].

14-25 Trip Delay at Torque Limit

Option:

Off

14-26 Trip Delay at Inverter Fault

Option:

0 - 30 s..... * 2s
Compressor dependent, factory set : read only

14-52 Fan Control

Option:

*Auto..... [0]
On 50%..... [1]
On 75%..... [2]
On 100%..... [3]

Function:

Select the minimum speed of the internal fan. Select *Auto* [0] to run the fan only when the internal temperature of the frequency converter is in the range 35 °C . approx. 55°C. The fan will run at low speed at 35C, and at full speed at approx. 55°C.

Parameters: Smart Logic Control

SLC (Smart Logic Controller) is not active by factory setting for "Open Loop" system control. For "Process Loop" factory setting" have been done in order to manage:

- **Pump-down function** (by mean of suction pressure sensor on input 54)

Cut-in pressure is set at 3.000 bar in parameter 13-12.0 (Comparator value)

Cut-out pressure is set 1.000 bar in parameter 13-12.1 (Comparator value)

- **Anti-short cycle** by adjusting minimum duration between two starts set at 5 minutes.

These 5 minutes are set in parameter 13-20.0 (SL Controller timer).

- **Oil return management** by having a minimum On-Time at each start-up. Default setting is 0 (zero) seconds by security. This parameter has to be adjusted in regards to each system, recommendation is about 30 seconds.

Setting is done on parameter 13-20.1 (SL Controller Timer)

The complete description of these parameter values and operand is done on the previous table" CD302 main parameters for VTX Compressors"

Smart Logic Control (SLC) is essentially a sequence of user defined actions (see par. 13-52 [x]) executed by the SLC when the associated user defined event (see par. 13-51 [x]) is evaluated as TRUE by the SLC. Events and actions are each numbered and linked together in pairs. This means that when *event* [0] is fulfilled (attains the value TRUE), *action* [0] is executed. After this, the conditions of *event* [1] will be evaluated and if evaluated TRUE, *action* [1] will be executed and so on. Only one event will be evaluated at any time. If an event is evaluated as FALSE, nothing happens (in the SLC) during the current scan interval and no other events will be evaluated. This means that when the SLC starts, it evaluates *event* [0] (and only *event* [0]) each scan interval. Only when event [0] is evaluated TRUE, will the SLC execute *action* [0] and start evaluating event [1]. It is possible to programme from 1 to 20 events and actions. When the last event / action has been executed, the sequence starts over again from *event* [0] / *action* [0].

Starting and stopping the SLC:

Starting and stopping the SLC can be done by selecting .On [1]. or .Off [0]. in par. 13-00. The SLC always starts in state 0 (where it evaluates event [0]). The SLC starts when the Start Event (defined in par. 13-01 Start Event) is evaluated as TRUE (provided that On [1] is selected in par. 13-00). The SLC stops when the Stop Event and reset the Smart Logic Control.

13-00 SL Controller Mode

Option:

*Off [0]
On [1]

Function:

Select *On* [1] to enable the Smart Logic Control to start when a start command is present, e.g. via a digital input.

Select *Off* [0] to disable the Smart Logic Control.

Instructions

Quick Set-up for VTZ Compressor Drive

Parameter N°	Par. Description	Default	As required change to	Comment
00-01	Language	English		Set to the language of your choice
01-13	Compressor Selection	Default package model		Only needed in the case of using over/undersized drive or R134a refrigerant
03-13	Reference site	linked to Hand (local) / Auto (remote)	Select Local or Remote	From where the operator will control the Frequency Converter. To use a local reference adjusted locally on the Drive select «local». To apply an external reference select «Remote». To use SLC (Smart Logic Control) it is always needed to push «Auto On».
03-15	Reference resource 1	Input 53	Leave as Input 53 or set to «No function»	If set point is modified via external reference: Leave as Input 53. If set point is fixed and set locally in Drive: Set to «No function»
05-10	Terminal 18	Start		Starting and stopping is controlled by a switch connected to terminal 18.
05-12	Terminal 27	Coast inverse		Stop function (coast inverse) linked to safety line of the system (HP, LP switches,...)
06-10	Terminal 53 Low Voltage	0		Minimum value in Volts for the reference signal. Only relevant if external reference is used (input 53 selected in 3-15)
06-11	Terminal 53 High Voltage	10		Maximum value in Volts for the reference signal. Only relevant if external reference is used (input 53 selected in 3-15)
0-20	Display	Frequency		
0-21	Display	Amps		
0-22	Display	Feedback [unit]		
0-23	Display	Speed [RPM]		
0-24	Display	AI 53		
5-40	Relay function	No Function		2 relays available. Can be used to deliver an external signal for [Alarm] or other abnormal values
14-20	Reset mode	Automatic x 10		If the specified number of AUTOMATIC RESET's is reached within 30 seconds, the frequency converter enters Manual reset
14-21	Reset time	30 Sec.		Interval between trip and automatic reset Par. [14-20]

Instructions

PID Closed Loop menu for VTZ Compressor Drive

Parameter N°	Par. Description	Default	For PID, change to	Comment
01-00	Configuration Mode	Speed Open Loop	Process	Allows the drive to receive a feedback from the refrigeration system, typically pressure or temperature. In the following it is assumed pressure feedback is used. Hence, the input frequency to the compressor can be adjusted according to de cooling demand.
03-01	Reference / Feedback Unit	rpm	Bar or psi	The feedback (suction pressure) can be displayed on the LCP in its appropriate unit.
03-02	Min. Reference	2100 rpm	-1 [Bar] (-100 if SLC is used)	Sets the minimum range for the pressure transmitter
03-03	Max. Reference	5400 rpm	12 [Bar] (100 if SLC is used)	Sets the maximum range for the pressure transmitter
03-10	Preset reference	0	Not necessary to change	Value will be added to the speed reference or to the set point for the PID control (closed loop)
03-13	Reference site	linked to Hand (local) / Auto (remote)	Select Local or Remote	From where the operator will control the Frequency Converter. To use a local reference adjusted locally on the Drive select «local». To apply an external reference select «Remote». To use SLC it is always needed to push «Auto On»
03-15	Reference resource 1	Input 53	Leave as Input 53 or set to «No function»	If PID set point is modified via external reference: Leave as Input 53. If set point is fixed and set locally in Drive: Set to «No function»
06-10	Terminal 53 Low Voltage	0	No change	Minimum value in Volts for the reference signal. Only relevant if external reference is used (input 53 selected in 3-15)
06-11	Terminal 53 High Voltage	10	No change	Maximum value in Volts for the reference signal. Only relevant if external reference is used (input 53 selected in 3-15)
06-14	Terminal 53 Low Reference / Feedb. value	2100	E.g. 1 [Bar]	Only relevant if external reference is used (input 53 selected in 3-15)
06-15	Terminal 53 High ref / Feed. value	5400	E.g. 5 [Bar]	Only relevant if external reference is used (input 53 selected in 3-15)
06-20	Terminal 54 Low Voltage	1V	Minimum value in V for the pressure transmitter's range	Depends on output from the feedback device. Normally no changes are needed
06-21	Terminal 54 High Voltage	5V	Maximum value in V for the pressure transmitter's range	Depends on output from the feedback device. Normally no changes are needed
06-22	Terminal 54 Low Current (only visible if switch set to I)	4	Minimum value in mA for the pressure transmitter's range	Depends on output from the feedback device. Normally no changes are needed
06-23	Terminal 54 High Current (only visible if switch set to I)	20	Maximum value in mA for the pressure transmitter's range	Depends on output from the feedback device. Normally no changes are needed
06-24	Terminal 54 Low ref / Feedb. value	-1	Value according to transmitter	Min value for range in Bar of pressure transmitter
06-25	Terminal 54 High ref / Feedb. value	9	Value according to transmitter	Min value for range in Bar of pressure transmitter
07-20	Process CL Feedback Input resource	Analog Input 54	If input 54 is used for transmitter no change is needed	Selects which input signal is used for PID-Closed loop control
07-33	Process PID Gain	2	According to system	Proportional gain of PID. Default values suitable for most systems for suction pressure control
07-34	Process PID Integration time (ms)	9000 ms	According to system	Integral time of PID in ms. Default value suitable for most systems for suction pressure control
SLC	Pressostat + Anti-short cycling function	Optional feature		Only active if 13-00 set to On
13-00	Smart Logic Controller On/Off	Off		Set only to On if pressostat function + anti short cycling are to be active
13-12.0	Comparator 0 (=cut-in pressure value)	3 Bar	Set desired start pressure	Pressostat function
13-12.1	Comparator 1 (=cut-out pressure value)	1 Bar	Set desired stop pressure	Pressostat function
13-20.0	Timer 0 (Start-to-Start timer)	5 min	Set desired time from start to start	Anti-short cycling function, 5 min = 12 starts per hour allowed
13-20.1	Timer 1 (Minimum Run-time)	0 min	Set desired minimum running time	Compressor will run for 1 min. before stopping

* SLC: Smart Logic Controller

Instructions

Factory set-up for Commun Parameters

Param Designation	Param number	Customer access	Common parameters for all compressors
Language	0-01	r/w	English
Motor Speed Unit	0-02	r/w	RPM
Regional Settings	0-03	r/w	International
Active set-up	0-10	Read	set-up 1
Edit set-up	0-11	r/w	active setup
Display Line 1.1 Small	0-20	r/w	Frequency
Display Line 1.2 Small	0-21	r/w	Motor Current
Display Line 1.3 Small	0-22	r/w	AI53
Display Line 2 Large	0-23	r/w	Speed [RPM]
Display Line 3 Large	0-24	r/w	Reference %
Configuration mode	1-00	r/w	Speed Open Loop
Control mode	1-01	Read	Flux Sensorless
Torque characteristics	1-03	Read	Constant Torque
Mode Selection	1-05	Read	As Conf. Mode P1-00
Motor Construction	1-10	Read	Asynchron
Frequency (Hz)	1-23	Read	90 Hz
Automatic Motor Adaptation	1-29	Read	Off
Motor poles	1-39	Read	2
Slip compens	1-62	Read	0%
Starting function	1-72	Read	Vcc+/Flux clockwise
Flying Start	1-73	Read	Disabled
Starting frequency	1-75	Read	As Par.1-74 in Hz
Starting current	1-76	Read	0,00 A
High Starting Torque Max Speed [rpm]	1-77	Read	as P4-11
Stop function	1-80	Read	Coast
Motor Thermal protection	1-90	r/w	No
Motor External Fan	1-91	r/w	No
Thermistor ressource	1-93	r/w	No
Motor Speed Direction	4-10	Read	Clockwise
Reference Range	3-00	r/w	Min - Max
Reference/Feedback Unit	3-01	r/w	rpm
Preset reference	3-10	r/w	0
Reference site	3-13	r/w	Linked Hand/Auto
Reference ressource 1	3-15	r/w	Input 53
Reference ressource 2	3-16	r/w	No Function
Reference ressource 3	3-17	r/w	No Function
Relative scalling reference ressource	3-18	r/w	No Function
Ramp up time running (sec)	3-41	r/w	9
Terminal 18 - Digital input	5-10	r/w	Start
Terminal 19 - Digital input	5-11	r/w	No Operation
Terminal 27 - Digital input	5-12	r/w	Coast inverse
Terminal 29 - Digital input	5-13	r/w	No Operation
Terminal 32 - Digital input	5-14	r/w	No Operation
Terminal 33 - Digital input	5-15	r/w	No Operation
Terminal 53 Low Voltage	6-10	r/w	0
Terminal 53 High Voltage	6-11	r/w	10
Terminal 53 Low Current (mA)	6-12	r/w	4
Terminal 53 High Current (mA)	6-13	r/w	20
Terminal 54 Low Voltage	6-20	r/w	1
Terminal 54 High Voltage	6-21	r/w	5
Terminal 54 Low Current (mA)	6-22	r/w	4
Terminal 54 High Current (mA)	6-23	r/w	20
Terminal 54 Low ref/Feedb.value	6-24	r/w	-1
Terminal 54 High ref/Feedb.value	6-25	r/w	12

Param Designation	Param number	Customer access	Common parameters for all compressors
Speed PID Feedback Source	7-00	Read	Motor Feedb. P1-02
PID Gain	7-02	Read	0,005
PID Integration time (ms)	7-03	Read	200
PID Diff. time	7-05	Read	Off
Process CL Feedback Input resource	7-20	r/w	Analog Input 54
Process PID control	7-30	r/w	Inverse
Process PID Anti Windup	7-31	r/w	ON
Process PID start speed	7-32	r/w	3000
Process PID Gain	7-33	r/w	2
Process PID Integration time (ms)	7-34	r/w	9
Process PID Diff. time	7-35	r/w	Off
Switching Frequency	14-01	r/w	4kHz
Overmodulation	14-03	r/w	On
Function at Mains Imbalance	14-12	r/w	Warning
Reset Mode	14-20	r/w	Auto. reset x 10
Automatic Restart Time (s)	14-21	r/w	30
Operation Mode	14-22	r/w	Normal operation
Trip Delay at Torque Limit	14-25	Read	Off
Trip Delay at Inverter Fault	14-26	Read	2
Fan Control	14-52	r/w	Auto
SL Controller Mode	1300	r/w	Off
Start Event	1301	r/w	Start command
Stop Event	1302	r/w	FALSE
Comparator Operand	1310.0	r/w	Feedback [unit]
Comparator Operand	1310.1	r/w	Feedback [unit]
Comparator Operator	1311.0	r/w	>
Comparator Operator	1311.1	r/w	<
Comparator Value	1312.0	r/w	3.000
Comparator Value	1312.1	r/w	1.000
SL Controller Timer	1320.0	r/w	00:05:00.000
SL Controller Timer	1320.1	r/w	00:00:00.000
Logic Rule Boolean 1	1340.0	r/w	Digital input DI18
Logic Rule Boolean 1	1340.1	r/w	Comparator 1
Logic Rule Operator 1	1341.0	r/w	AND
Logic Rule Operator 1	1341.1	r/w	OR NOT
Logic Rule Boolean 2	1342.0	r/w	Comparator 0
Logic Rule Boolean 2	1342.1	r/w	Digital input DI18
Logic Rule Operator 2	1343.0	r/w	AND
Logic Rule Operator 2	1343.1	r/w	DISABLED
Logic Rule Boolean 3	1344.0	r/w	Start command
Logic Rule Boolean 3	1344.1	r/w	FALSE
SL Controller Event	1351.0	r/w	VRAI
SL Controller Event	1351.1	r/w	Logic rule 0
SL Controller Event	1351.2	r/w	TRUE
SL Controller Event	1351.3	r/w	TRUE
SL Controller Event	1351.4	r/w	SL Time-out 1
SL Controller Event	1351.5	r/w	Logic rule 1
SL Controller Event	1351.6	r/w	SL Time-out 0
SL Controller Action	1352.0	r/w	Stop
SL Controller Action	1352.1	r/w	Start timer 0
SL Controller Action	1352.2	r/w	Start timer 1
SL Controller Action	1352.3	r/w	Run
SL Controller Action	1352.4	r/w	No action
SL Controller Action	1352.5	r/w	Stop
SL Controller Action	1352.6	r/w	No action

Instructions

Compressor specific parameters for code G R404A/R407C

			CD 302 4kW	CD 302 5,5kW	CD 302 7,5kW	CD 302 11kW	CD 302 15kW	CD 302 18,5kW	CD 302 22kW
Param Designation	Param number	Customer access	VTZ038-G	VTZ054-G	VTZ086-G	VTZ121-G	VTZ171-G	VTZ215-G	VTZ242-G
Torque	1-04	Read	High Torque	High Torque	High Torque	Normal Torque	Normal Torque	Normal Torque	Normal Torque
Compressor Selection	1-13	r/w	VTZ038-R404A/407C	VTZ054-R404A/407C	VTZ086-R404A/407C	VTZ121-R404A/407C	VTZ171-R404A/407C	VTZ215-R404A/407C	VTZ242-R404A/407C
Motor Power (kW)	1-20	Read	3,59	4,95	7,8	11,66	16	21,3	23,56
Motor Voltage (V)	1-22	Read	414V	414V	414V	414V	414V	414V	414V
Current (A)	1-24	Read	7,35	12	16	25,1	30,5	40,8	45,9
RPM	1-25	Read	5290	5290	5290	5290	5290	5290	5290
Rs (Ohm)	1-30	Read	1,684	1,039	0,685	0,294	0,337	0,236	0,186
Rrot (Ohm)	1-31	Read	1,477	1,029	0,656	0,410	0,456	0,309	0,278
stat leak (Ohm)	1-33	Read	4,01	3,31	1,08	0,580	0,6	0,39	0,36
Rot leak (Ohm)	1-34	Read	1,520	1,250	1,080	0,580	0,6	0,39	0,36
X main (Ohm)	1-35	Read	107,70	50,04	28,7	17,190	19,61	11,5	15,23
Iron Loss Resistance (Rfe)	1-36	Read	5044	1090	501,3	320,9	143,700	271,600	283,400
Min current at low speed	1-66	r/w	125%	125%	100%	100%	100%	100%	100%
Inertia Mini	1-68	Read	0,0011	0,0014	0,0028	0,0039	0,0066	0,0083	0,00987
Inertia Maxi	1-69	Read	0,0033	0,0068	0,009	0,012	0,02	0,025	0,03
Starting delay	1-71	Read	0,5	0,5	0,5	0,5	0	0	0
Starting speed	1-74	Read	90 RPM	90 RPM	-90 RPM	-90 RPM	90 RPM	90 RPM	90 RPM
Speed limit for stop function	1-81	Read	1800	1800	1500	1500	1500	1500	1500
Min reference	3-02	r/w	2100	2100	1800	1800	1800	1800	1800
Max reference	3-03	r/w	5400	5400	5400	5100	5400	5400	5100
Ramp down time running (sec)	3-42	r/w	0,3	0,3	0,3	0,3	1	1	1
Starting Ramp Up Time	3-82	Read	0,54	0,54	0,54	0,54	1,26	1,26	1,26
Motor speed low limit (rpm)	4-11	Read	2100	2100	1800	1800	1800	1800	1800
Motor speed low limit (Hz)	4-12	Read	34,2	34,2	29,2	29,2	29,2	29,2	29,2
Motor speed high limit (rpm)	4-13	Read	5400	5400	5400	5100	5400	5400	5100
Motor speed high limit (Hz)	4-14	Read	90,8	90,8	90,8	85,8	90,8	90,8	85,8
Torque lim motor running (%)	4-16	Read	133%	190%	160%	160%	160%	160%	160%
Current limit running (%)	4-18	r/w	110%	108%	100%	110%	110%	110%	110%
Maximum output frequency (Hz)	4-19	Read	95	95	95	90	95	95	90
Warning Current High (A)	4-51	r/w	as p1-24	as p1-24	as p1-24	as p1-24	as p1-24	as p1-24	as p1-24
Warning speed low (rpm)	4-52	r/w	as p4-11	as p4-11	as p4-11	as p4-11	as p4-11	as p4-11	as p4-11
Warning speed High (rpm)	4-53	r/w	as p4-13	as p4-13	as p4-13	as p4-13	as p4-13	as p4-13	as p4-13
Terminal 53 Low ref/Feedb.value	6-14	r/w	as p3-02 (not linked)	as p3-02 (not linked)	as p3-02 (not linked)	as p3-02 (not linked)	as p3-02 (not linked)	as p3-02 (not linked)	as p3-02 (not linked)
Terminal 53 High ref/Feedb.value	6-15	r/w	as p3-03 (not linked)	as p3-03 (not linked)	as p3-03 (not linked)	as p3-03 (not linked)	as p3-03 (not linked)	as p3-03 (not linked)	as p3-03 (not linked)

Instructions

Compressor specific parameters for code J R404A/R407C

Param Designation	Param number	Customer access	CD 302 3.7kW	CD 302 5,5kW	CD 302 7,5kW	CD 302 11kW
			VTZ038-J 200V	VTZ054-J 200V	VTZ086-J 200V	VTZ121-J 200V
Torque	1-04	Read	High Torque	High Torque	High Torque	Normal Torque
Compressor Selection	1-13	r/w	VTZ038-R404A/407C	VTZ054-R404A/407C	VTZ086-R404A/407C	VTZ121-R404A/407C
Motor Power (kW)	1-20	Read	3,59	5	7,8	12,5
Motor Voltage (V)	1-22	Read	205 V	205 V	205 V	205 V
Current (A)	1-24	Read	13,5	20	32,5	50
RPM	1-25	Read	5290	5290	5200	5200
Rs (Ohm)	1-30	Read	0,31	0,215	0,158	0,095
Rrot (Ohm)	1-31	Read	0,434	0,343	0,150	0,088
stat leak (Ohm)	1-33	Read	0,66	0,48	0,255	0,162
Rot leak (Ohm)	1-34	Read	0,331	0,240	0,255	0,162
X main (Ohm)	1-35	Read	19,97	17,484	6,665	7,775
Iron Loss Resistance (Rfe)	1-36	Read	504,4	110,00	60	65,7
Min current at low speed	1-66	r/w	110%	100%	100%	100%
Inertia Mini	1-68	Read	0,0011	0,0014	0,0028	0,0039
Inertia Maxi	1-69	Read	0,0033	0,0068	0,009	0,012
Starting delay	1-71	Read	0,5	0,5	0,5	0,5
Starting speed	1-74	Read	90 RPM	90 RPM	-90 RPM	-90 RPM
Speed limit for stop function	1-81	Read	1800	1800	1500	1500
Min reference	3-02	r/w	2100	2100	1800	1800
Max reference	3-03	r/w	5400	5400	5400	5100
Ramp down time running (sec)	3-42	r/w	0,3	0,3	0,3	0,3
Starting Ramp Up Time	3-82	Read	0,54	0,54	0,54	0,54
Motor speed low limit (rpm)	4-11	Read	2100	2100	1800	1800
Motor speed low limit (Hz)	4-12	Read	34,2	34,2	29,2	29,2
Motor speed high limit (rpm)	4-13	Read	5400	5400	5400	5100
Motor speed high limit (Hz)	4-14	Read	90,8	90,8	90,8	85,8
Torque lim motor running (%)	4-16	Read	133%	190%	160%	160%
Current llimit running (%)	4-18	r/w	110%	110%	110%	110%
Maximum output frequency (Hz)	4-19	Read	95	95	95	90
Warning Current High (A)	4-51	r/w	as p1-24	as p1-24	as p1-24	as p1-24
Warning speed low (rpm)	4-52	r/w	as p4-11	as p4-11	as p4-11	as p4-11
Warning speed High (rpm)	4-53	r/w	as p4-13	as p4-13	as p4-13	as p4-13
Terminal 53 Low ref/Feedb.value	6-14	r/w	as p3-02 (not linked)	as p3-02 (not linked)	as p3-02 (not linked)	as p3-02 (not linked)
Terminal 53 High ref/Feedb.value	6-15	r/w	as p3-03 (not linked)	as p3-03 (not linked)	as p3-03 (not linked)	as p3-03 (not linked)

Instructions

Compressor specific parameters for code G R134a

			CD 302 4kW	CD 302 5.5 kW	CD 302 5,5kW	CD 302 11kW	CD 302 11kW	CD 302 15kW	CD 302 15kW
Param Designation	Param number	Customer access	VTZ038-G	VTZ054-G	VTZ086-G	VTZ121-G	VTZ171-G	VTZ215-G	VTZ242-G
Torque	1-04	Read	High Torque	High Torque	High Torque	Normal Torque	Normal Torque	Normal Torque	Normal Torque
Compressor Selection	1-13	r/w	VTZ038-R134a	VTZ054-R134a	VTZ086-R134a	VTZ121-R134a	VTZ171-R134a	VTZ215-R134a	VTZ242-R134a
Motor Power (kW)	1-20	Read	3,59	4,95	7,8	11,66	16	21,3	23,56
Motor Voltage (V)	1-22	Read	414V	414V	414V	414V	414V	414V	414V
Current (A)	1-24	Read	7,35	12	16	25,1	30,5	40,8	45,9
RPM	1-25	Read	5290	5290	5290	5290	5290	5290	5290
Rs (Ohm)	1-30	Read	1,684	1,039	0,685	0,294	0,337	0,236	0,186
Rrot (Ohm)	1-31	Read	1,477	1,029	0,656	0,410	0,456	0,309	0,278
stat leak (Ohm)	1-33	Read	4,01	3,31	1,08	0,580	0,6	0,39	0,36
Rot leak (Ohm)	1-34	Read	1,520	1,250	1,080	0,580	0,6	0,39	0,36
X main (Ohm)	1-35	Read	107,70	50,04	28,7	17,190	19,61	11,5	15,23
Iron Loss Resistance (Rfe)	1-36	Read	5044	1090	501,3	320,9	143,700	271,600	283,400
Min current at low speed	1-66	r/w	90%	90%	90%	90%	90%	90%	90%
Inertia Mini	1-68	Read	0,0011	0,0014	0,0028	0,0039	0,0066	0,0083	0,00987
Inertia Maxi	1-69	Read	0,0033	0,0068	0,009	0,012	0,02	0,025	0,03
Starting delay	1-71	Read	0,5	0,5	0,5	0,5	0	0	0
Starting speed	1-74	Read	90 RPM	90 RPM	-90 RPM	-90 RPM	90 RPM	90 RPM	90 RPM
Speed limit for stop function	1-81	Read	1800	1800	1500	1500	1500	1500	1500
Min reference	3-02	r/w	2100	2100	1800	1800	1800	1800	1800
Max reference	3-03	r/w	5400	5400	5400	5100	5400	5400	5100
Ramp down time running (sec)	3-42	r/w	0,3	0,3	0,3	0,3	1	1	1
Starting Ramp Up Time	3-82	Read	0,54	0,54	0,54	0,54	1,26	1,26	1,26
Motor speed low limit (rpm)	4-11	Read	2100	2100	1800	1800	1800	1800	1800
Motor speed low limit (Hz)	4-12	Read	34,2	34,2	29,2	29,2	29,2	29,2	29,2
Motor speed high limit (rpm)	4-13	Read	5400	5400	5400	5100	5400	5400	5100
Motor speed high limit (Hz)	4-14	Read	90,8	90,8	90,8	85,8	90,8	90,8	85,8
Torque lim motor running (%)	4-16	Read	133%	190%	160%	160%	160%	160%	160%
Current llimit running (%)	4-18	r/w	82%	73%	80%	80%	80%	85%	110%
Maximum output frequency (Hz)	4-19	Read	95	95	95	90	95	95	90
Warning Current High (A)	4-51	r/w	as p1-24	as p1-24	as p1-24	as p1-24	as p1-24	as p1-24	as p1-24
Warning speed low (rpm)	4-52	r/w	as p4-11	as p4-11	as p4-11	as p4-11	as p4-11	as p4-11	as p4-11
Warning speed High (rpm)	4-53	r/w	as p4-13	as p4-13	as p4-13	as p4-13	as p4-13	as p4-13	as p4-13
Terminal 53 Low ref/Feedb.value	6-14	r/w	as p3-02 (not linked)	as p3-02 (not linked)	as p3-02 (not linked)	as p3-02 (not linked)	as p3-02 (not linked)	as p3-02 (not linked)	as p3-02 (not linked)
Terminal 53 High ref/Feedb.value	6-15	r/w	as p3-03 (not linked)	as p3-03 (not linked)	as p3-03 (not linked)	as p3-03 (not linked)	as p3-03 (not linked)	as p3-03 (not linked)	as p3-03 (not linked)

