

ENGINEERING
TOMORROW

Danfoss

Application guidelines

Danfoss scroll compressors **VLZ028-035-044** Single

R404A/R448A/R449A



ЮГОВ - Проект

інженерно-виробниче підприємство

Офіційний дистриб'ютор
Danfoss в Україні



ugov.ua

<http://cc.danfoss.com>

GENERAL INFORMATION.....	4	Manage off cycle migration.....	28
		Requirement.....	28
		System evaluation	28
PRODUCT INFORMATION	5	Provide power supply and electrical protection	30
Features.....	5	Wiring diagram of CDS803	30
Compressor model designation	6	Wiring connections of CDS803	31
Nomenclature	6	Soft-start control.....	31
Technical specifications.....	7	Control logic	32
Dimensions	9	Safety control logic requirements.....	32
Single compressors	9	Defrost cycle logic.....	33
Electrical data, connections and wiring	12	Pump-down logic recommendations.....	33
Supply voltage.....	12	Oil management logic	34
Phase sequence and reverse rotation protection.....	14	Reduce moisture in the system	35
IP rating.....	15	Requirements.....	35
Motor protection.....	15	Solutions.....	35
Approval and certificates	16	INTEGRATION INTO SYSTEMS.....	36
Low voltage directive 2014/35/EU.....	16	Assembly line procedure.....	36
Internal free volume.....	16	Compressor storage.....	36
SYSTEM DESIGN.....	17	Compressor holding charge	36
Design piping	17	Handling	36
General requirements	17	Piping assembly.....	37
Design compressor mounting	18	System pressure test and leak detection	37
General requirements	18	Vacuum evacuation and moisture removal ..	38
Single requirements.....	18	Refrigerant charging.....	38
Manage oil in the circuit	19	Dielectric strength and insulation resistance tests.....	38
Requirement.....	19	Commissioning.....	39
System evaluation	19	Preliminary check.....	39
Test, criteria and solutions	19	Initial start-up.....	39
Manage sound and vibration.....	20	System monitoring.....	39
Compressor sound radiation.....	20	Oil level checking and top-up.....	39
Mechanical vibrations.....	21	Troubleshooting.....	40
Gas pulsation.....	21	Dismantal and disposal	43
Manage operating envelope.....	22	ORDERING INFORMATION	44
Requirement.....	22	Packaging	44
Speed limit requirement.....	24	Ordering codes.....	45
Start/Stop/Ramp setting.....	24	Accessories.....	46
Short cycle protection	25		
Manage superheat	26		
Requirement.....	26		
System evaluation	26		
Test, criteria and solutions	27		

GENERAL INFORMATION
PRODUCT INFORMATION
SYSTEM DESIGN
INTEGRATION INTO SYSTEM
ORDERING INFORMATION

Danfoss scroll compressors are designed and manufactured according to the state of the art and to valid European and US regulations. Particular emphasis has been placed on safety and reliability. Related instructions are highlighted with the following icons:

 This icon indicates instructions to avoid safety risk.

 This icon indicates instructions to avoid reliability risk.

The purpose of this guideline is to help customers qualify compressors in the unit. You are strongly advise to follow these instructions. For any deviation from the guidelines, please contact Danfoss Technical Support. In any case, Danfoss accepts no liability as a result of the improper integration of the compressor into the unit by the system manufacturer.

Features

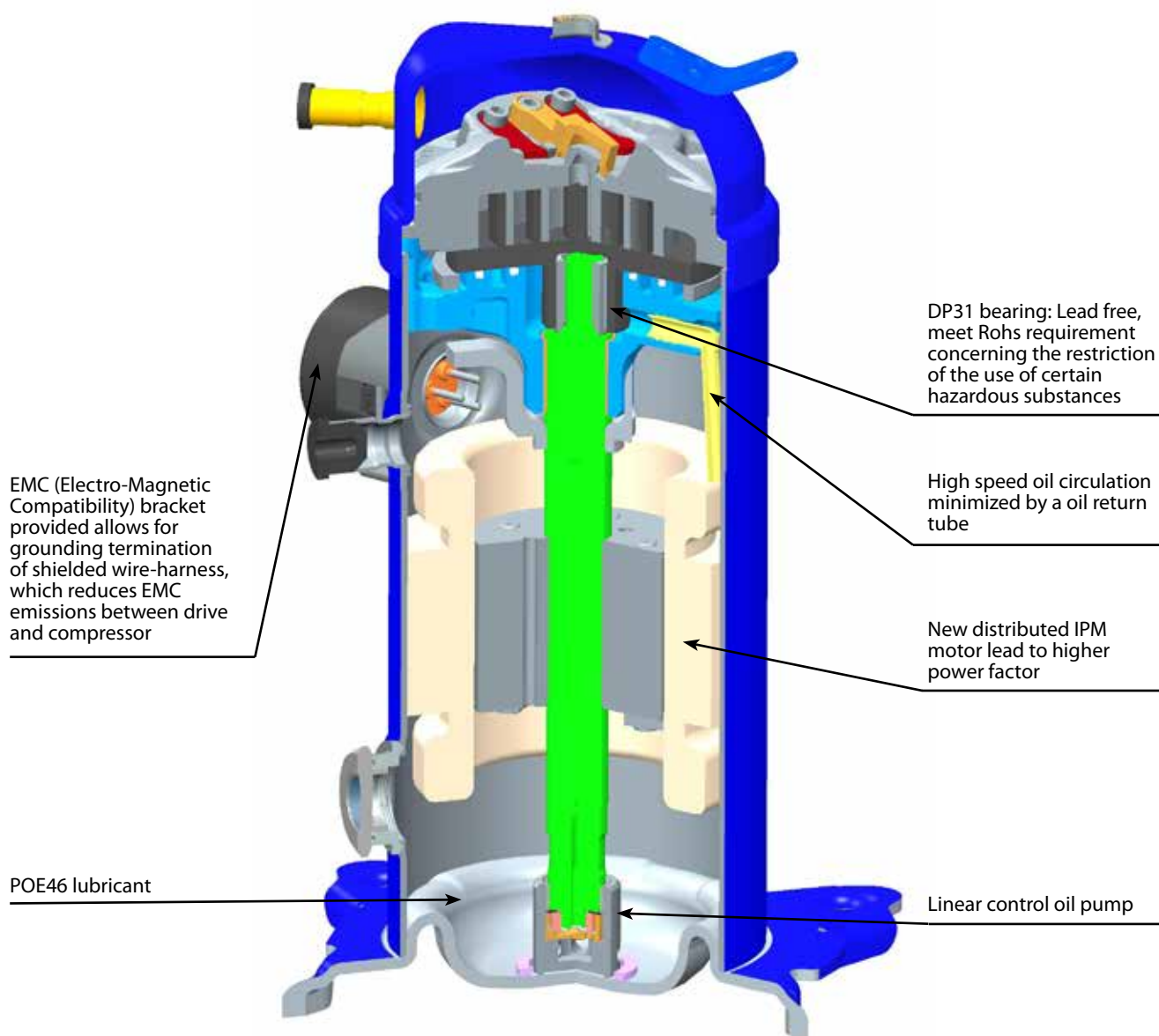

GENERAL INFORMATION
PRODUCT INFORMATION
SYSTEM DESIGN
INTEGRATION INTO SYSTEM
ORDERING INFORMATION

Compressor model designation

Nomenclature

Compressor nomenclature

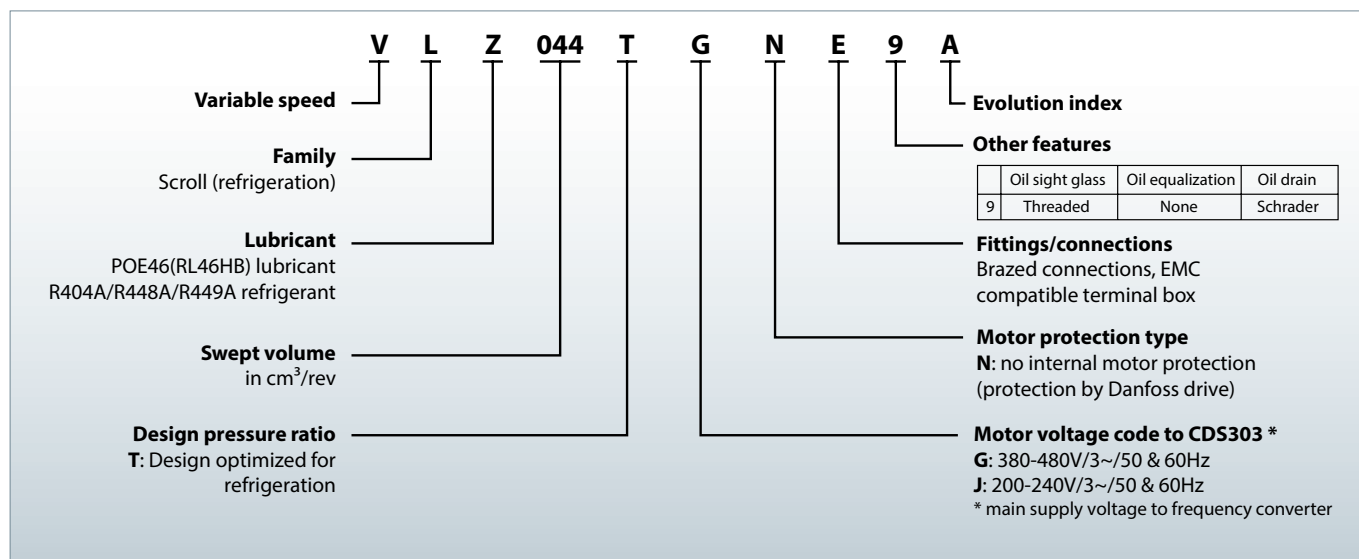

Frequency converter nomenclature

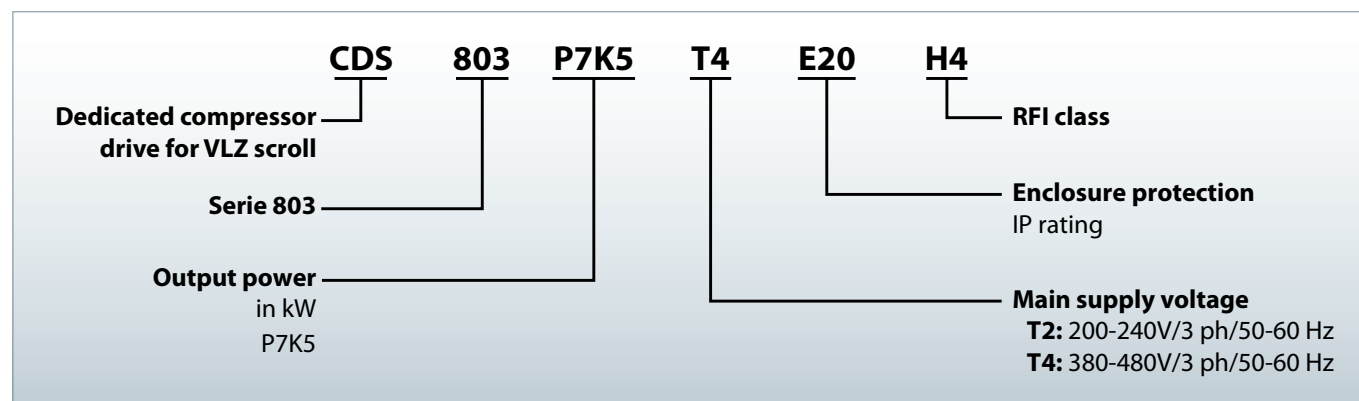

Technical specifications

Compressor size

To have the optimum compressor selection, select a compressor size which achieves the peak load system cooling capacity demand at its maximum speed.

Detailed performances can be found in datasheets and in selection programs.

Frequency converter variants

Different frequency converter variants are available according to:

1. Mains supply voltage
2. IP class

3. RFI (Radio Frequency Interference) class H4
4. Printed Circuit Board (PCB) coated

Compressor and frequency converter combinations

When the compressor size and mains voltage have been defined in the above selection criteria, the code number tables from the "Ordering information and packaging" section provides the appropriate frequency converter sizes.

⚠ Note this compressor is equipped with a four-pole electrical motor so the applied frequency from the inverter will be 60 Hz for 30rps(1800 rpm) up to 200 Hz for 100 rps(6000 rpm).

Please refer to the table below

		min	max
Compressor speed	rps	30	100
	rpm	1800	6000
Drive output frequency	Hz	60	200

Technical specifications

Compressor specifications

Compressor model	Swept volume (cm ³ /rev)	Displacement				Oil charge (Liters)	Net weight (kg)
		30 rps (m ³ /h)	50 rps (m ³ /h)	60 rps (m ³ /h)	100 rps (m ³ /h)		
VLZ028	27.8	3.0	5.0	6.0	10.0	1.3	26
VLZ035	34.9	3.8	6.3	7.5	12.6	1.3	27
VLZ044	44.5	4.8	8.0	9.6	16.0	1.3	27

Frequency converter specifications

Mains supply voltage	CDS803-T2: 200 - 240 V +/-10% (3-phase) CDS803-T4: 380 - 480 V +/-10% (3-phase)
Supply frequency	50 / 60 Hz
Output voltage	0 - 100 % of supply voltage
Standby power	T2: P7K5: 23.17W T4: P7K5: 11.3W
Inputs	CDS803: 4 digital (0 - 24 V), 2 analog (0 /±10 V or 4 - 20 mA, scalable)
Programmable outputs	CDS803: 2 digital (0- 24 V), 2 analog (0-24 V), 2 relay
Protection functions	Over-current protection, low / high current handling
Compressor functions	Pressostat / thermostat function, short cycle protection, oil return management

POE

The POE oil RL46HB(215PZ) is an ISO VG 46 synthetic polyol ester (POE) lubricant formulated specifically for use in refrigeration and air conditioning compressors using HFC refrigerants.

system life and improved efficiency and is suitable for both initial fill and service fill. The combination of low temperature characteristics and unparalleled chemical and thermal stability enable the use of RL46HB over a wide operating temperature range.

This product provides effective wear protection for steel and aluminum surfaces for increased

R448A & R449A

R448A and R449A are two HFO-based refrigerants with similar properties. Both have a GWP below 1500 and comply with the EU F-gas regulation.

R448A&R449A have zero ozone depletion potential (ODP = 0). R448A&449A are especially suitable for low evaporating temperature applications but they can also be applied to medium evaporating temperature applications. R448A &449A are mixtures and have big temperature glide, and therefore must be charged in their gas phase.

They can be used as alternatives to R404A refrigerants in MBP application.

R404A

R404A is an HFC refrigerant. R404A has zero ozone depletion potential (ODP = 0). R404A is also suitable for low evaporating temperature applications but it can also be applied to medium evaporating temperature applications. R404A is a mixture and has a very

small temperature glide, and therefore must be charged in its liquid phase, but for most other aspects this small glide can be neglected.

Because of the small glide, R404A is often called a near-azeotropic mixture.

Designation	Composition	ODP	GWP	Safety group	Boiling temp °C	Temp glide °C	Critical temp °C	Critical pressure bar	Cond temp @ 26babs
R404A	52% R143a - 44% R125 - 4% R134a	0	3943	A1	-45.5	0.8	73.0	36.9	55.8
R448A	21% R134a - 20% R1234yf 26% R125 - 26% R32 - 7% R1234ze	0	1273	A1	-46.1	6.1	83.7	48.0	58.1
R449A	24.3% R32 - 24.7% R125 25.3% R1234yf - 25.7% R134a	0	1282	A1	-45.7	6.0	83.9	44.5	58.2

Dimensions

Single compressors

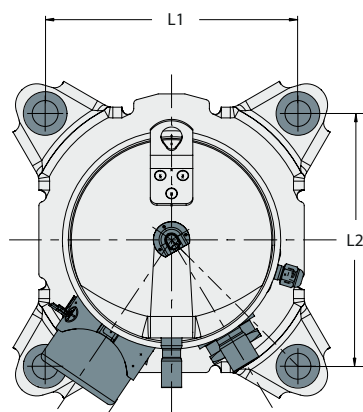
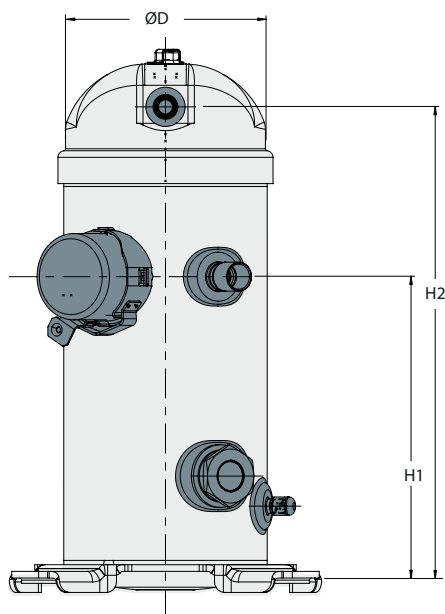

Single version

Terminal box (quick connect spade terminals)

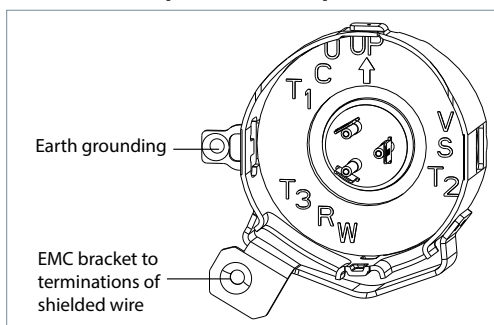

Mounting Grommet

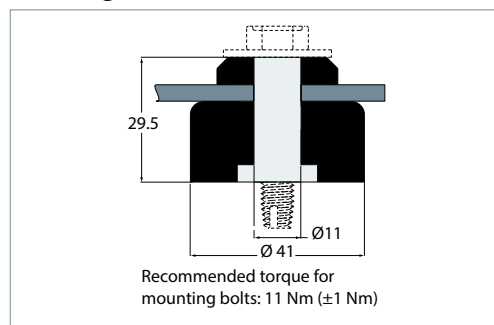

Version	Compressor model	D(mm)	H(mm)	H1(mm)	H2(mm)	L1(mm)	L2(mm)	Outline drawing number
Single	VLZ028-035-044	164.5	404.4	230.5	360.4	190.5	190.5	0VG8213B

Dimensions

Connection Details

VLZ028-035-044 single version	
Suction connection	Brazed 3/4"
Discharge connection	Brazed 1/2"
Oil sight glass	Threaded (1"1/8 – 18 UNF)
Oil equalization connection	-
Schrader	Male 1/4" Flare incorporating a Schrader valve

1) VLZ compressors single versions come equipped with a threaded oil sight glass with 1"1/8 – 18 UNEF connection. It can be used for a visual check of oil amount and condition.

2) Schrader: The oil fill connection and gauge port is a 1/4" male flare connector incorporating a Schrader valve.

VLZ compressors are all delivered with suction and discharge brazed connections only. They are copper-plated steel connections.

Rotolock adaptors are available, refer to the information above.



Compressor models	Brazed connection size		Rotolock adaptor set (①adaptor, ②gasket, ③sleeve, ④nut)			Rotolock adaptor (① adaptor only)
			Rotolock	Solder sleeve ODF	Code Number	Code Number
VLZ028-035-044	Suction	3/4"	1-1/4"	3/4"	120Z0126	120Z0366
	Discharge	1/2"	1"	1/2"		120Z0365

GENERAL INFORMATION

PRODUCT INFORMATION

SYSTEM DESIGN

INTEGRATION INTO SYSTEM

ORDERING INFORMATION

Dimensions

CDS803 Frequency converter

Frequency converter dimensions depend on supply voltage and power. The table below gives an overview of the overall dimensions and different drive enclosures (H3-H4). Details for each drive enclosure are on the following pages.

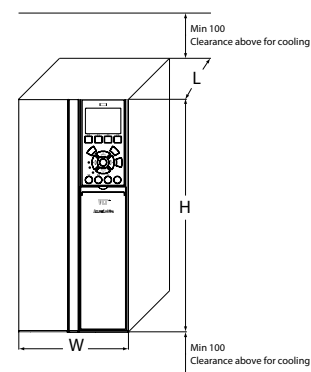

Drive supply voltage	Drive power kW	Compressor voltage code	Compressor model	IP20			
				Drive enclosure	Overall drive size (H x W x L) mm	Overall drive size (H x W x L) mm incl. decoupling plate	Clearance above/below (mm/inch)
T2: 200-240/3/50-60	7.5	J	VLZ028-035-044	H4	296x135x241	359x135x241	100/4
T4: 380-480/3/50-60	7.5	G	VLZ028-035-044	H3	255x100x206	329x100x206	100/4

CDS803 frequency converter

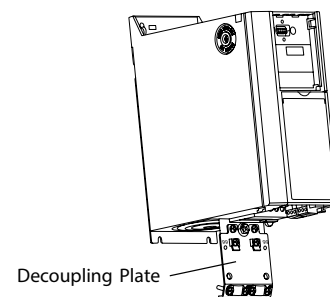
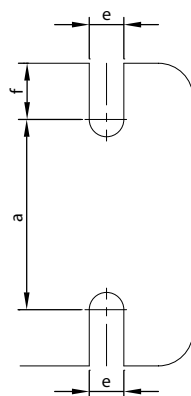
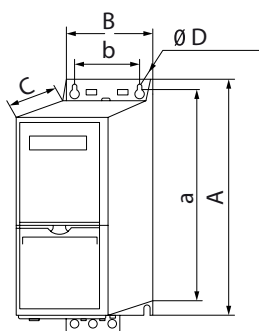

Decoupling Plate Illustration

Enclosure		Height (mm)			Width (mm)		Depth (mm)	Mounting hole (mm)			Max. Weight
Frame	IP Class	A	A ¹⁾	a	B	b	C	d	e	f	kg
H3	IP20	255	329	240	100	74	206	11	5.5	8.1	4.5
H4	IP20	296	359	275	135	105	241	12.6	7	8.4	7.9

A¹⁾Including decoupling plate.

The dimensions are only for the physical units, but when installing in an application it is necessary to add space for free air passage both above and below the units. The amount of space for free air passage is listed in "frequency converter dimensions - Clearance above/below (mm/inch)".

Electrical data, connections and wiring

Supply voltage

Because VLZ compressors are powered by a frequency converter, the mains frequency, 50 or 60 Hz, is no longer an issue. Only the mains voltage is to be taken into account. With 2 motor voltage codes, the most common mains voltages and frequencies are covered. VLZ compressors will only work normally when connect to a frequency converter. Connect VLZ compressors

to the mains power supply directly will cause compressor motor get burnt.

Voltage code	Mains voltage range of drive
J	200-240V / 3ph / 50Hz & 200-240V / 3ph / 60Hz (±10%)
G	380-480V / 3ph / 50Hz & 380-480V / 3ph / 60Hz (±10%)

Compressor electrical specifications

Compressor rated voltage (V)	Model	RW(Ω) at 20°C line to line	RLA (A)	Max Operating Current (A)
400	VLZ044	0.708Ω±7%	10.5	12.1
400	VLZ035		8.5	9.8
400	VLZ028		7	8.1
208	VLZ044	0.185Ω±7%	22.1	25.4
208	VLZ035		19.7	22.7
208	VLZ028		14.6	16.8

RW: Winding resistance per winding, measured at motor terminals
 RLA: Rated load Amp

RLA (Rated Load Amp)

Rated Load Amp value is the current value at maximum load, in the operating envelope, and at

maximum speed and rated drive input voltage.

MOC (Max Operating Current)

Max operating current is the maximum continuous current which is 115% of RLA. This value is printed on compressor nameplate.

Wiring connections

VLZ scroll compressors will only compress gas while rotating counter-clockwise (when viewed from the top of the compressor).

The drawing shows electrical terminal labeling and should be used as a reference when wiring the compressor.

U, V & W of the drive and the compressor must be connected accordingly.

For use of EMC bracket with shielded cable, it is recommended to have a thread cutting screw (#10-32) having a torque of 3NM.

Earth grounding

EMC bracket to terminations of shielded wire

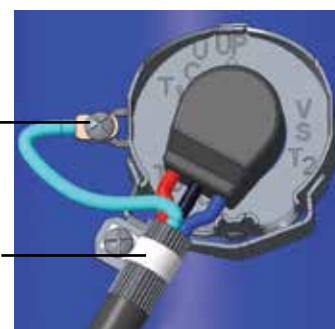

Terminal cover mounting

The terminal cover and gasket should be installed prior to operation of the compressor. The terminal cover has two outside tabs, 180 degrees apart,

that engage the terminal fence. When installing the cover, check that it is not pinching the lead wires.

Terminal cover removal

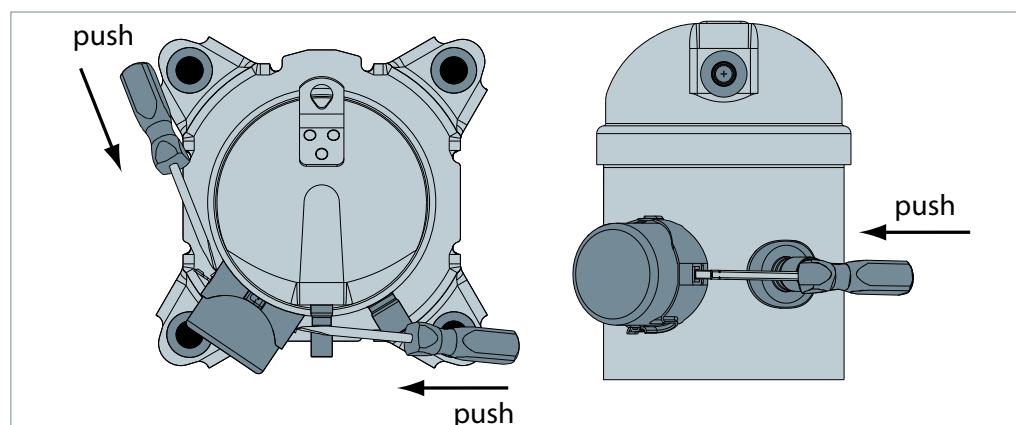

Electrical data, connections and wiring

Fuses

Danfoss recommends using the fuses listed below to protect service personnel and property in case of component break-down in the frequency converter.

For circuit breakers, Moeller types have been tested and are recommended. Other types of circuit breakers may be used provided they limit the energy to a level equal to or lower than the Moeller types.

CDS 803	UL Compliant fuses					Recommended circuit breaker
	UL				Non UL	IP20
	Bussmann	Bussmann	Bussmann	Bussmann	Max fuse	Moeller type
	Type RK5	Type RK1	Type J	Type T	Type G	
3x200-240 V IP20						
VLZ028-035-044	FRS-R-50	KTN-R50	JKS-50	JJN-50	50	PKZM4-50
3x380-480 V IP20						
VLZ028-035-044	FRS-R-25	KTS-R25	JKS-25	JJS-25	25	PKZM4-25

Wire sizes

Below table lists recommended wiring sizes for the motor compressor power supply cables. These wiring sizes are valid for a cable length up to 20 m.

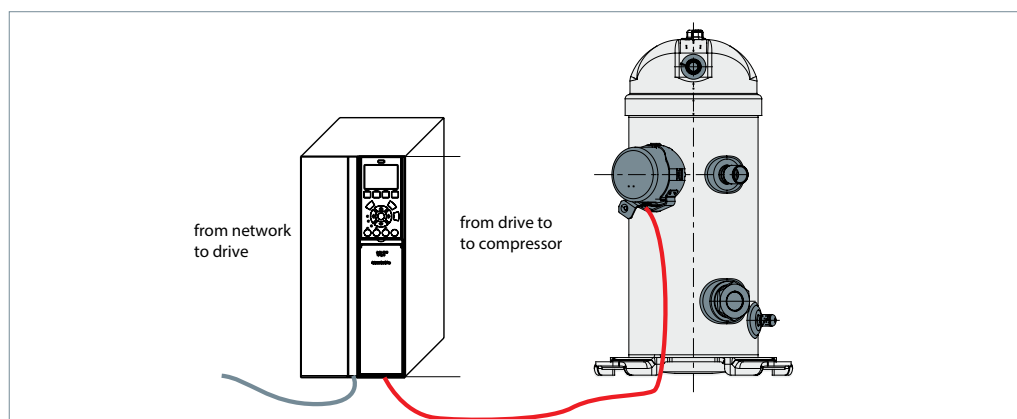

	From network to frequency converter			From frequency converter to compressor		
	Type	mm ²	AWG	Type	mm ²	AWG
200 - 240 V	CDS803-7.5kW(IP20)	6	10	VLZ028/035/044-J	6	10
380 - 400 V	CDS803-7.5kW(IP20)	4	10	VLZ028/035/044-G	4	10

Note: The wire size here is the guidelines but not the actual needed cable. The needed cable size should be specified by the OEM depending on the unit design, ambient temperature, the wire material, current, etc...

GENERAL INFORMATION

Wiring & EMC protection

The motor compressor power supply from the CDS803 frequency converter to the VLZ compressor must be done with a braided screened / armored cable. This cable needs to have its screen / armor conduit connected to earth on both ends. Avoid terminating this cable connection with twisting ends (pigtails) because that would result in an antenna phenomena and decrease the effectiveness of the cable.

Control cables to the CDS803 frequency converter must use the same installation principles as the power supply cable.

The motor compressor cable must be installed in a conduit separated from the control and mains cables.

Physical installation of the frequency converter on the mounting plate must ensure good electrical contact between the mounting plate and the metal chassis of the converter. Use star-washers and galvanically conductive installation plates to secure good electrical connections. Refer to instructions MG18N102 for tightening torques and screw sizes.

Note that the CDS803 must be mounted on a plain wall to ensure a good air flow through its heat exchanger.

PRODUCT INFORMATION

Soft-start control

The CDS803 frequency converter generates by design a compressor soft start with an default initial ramp up of 7.5s to 50 rps.

Current inrush will not exceed the frequency converter maximum current.

Basically seen from the mains the inrush peak reach a level which is only a few percent more than the rated nominal current.

SYSTEM DESIGN

Phase sequence and reverse rotation protection

The compressor will only operate properly in a single direction. If electrical connections are done correctly between the drive and the compressor terminals (compressor and drive terminals U, V & W matching), the drive will provide correct phase supply to the compressor, and reverse rotation will be not possible:

- CDS terminal U (96) to VLZ terminal T1/U
- CDS terminal V (97) to VLZ terminal T2/V
- CDS terminal W (98) to VLZ terminal T3/W

If compressor and drive U, V & W terminals are not matching, the compressor can operate in a reverse rotation. This results in excessive noise, no pressure differential between suction and

discharge, and suction line warming rather than immediate cooling. The compressor can be rapidly damaged in these conditions. To protect compressors from reverse rotation, below action is recommended:

- Use pressure sensors to monitor pressure difference between discharge and suction of the compressor, and for normal operation, discharge pressure should be at least 1 bar higher than suction pressure within 30 s running after compressor starting.

Mains connection to the CDS frequency converter order has no influence on the output phase sequence which is managed by the frequency converter.

INTEGRATION INTO SYSTEM

ORDERING INFORMATION

IP rating

The compressor terminal box IP rating according to IEC529 is IP22.

Element	Numerals or letters	Meaning for the protection of equipment
First characteristic numeral	0 1 2 3 4 5 6	Against ingress of solid foreign objects (non protected) ≥ 50 mm diameter ≥ 12.6 mm diameter ≥ 2.5 mm diameter ≥ 1.0 mm diameter dust protected dust tight
Second characteristic numeral	0 1 2 3 4 5 6 7 8	Against ingress of water with harmful effects (non protected) vertically dripping dripping (15° tilted) spraying splashing jetting powerful jetting temporary immersion continuous immersion

Motor protection

VLZ scroll compressors are not equipped with an internal motor protector. Motor protection is provided by the variable speed drive. All parameters are factory preset in order to guaranty locked rotor or overload current protection.

When a warning situation is reached in the current control, the CDS frequency converter will automatically reduce the compressor speed in order to keep the motor current of the compressor below the maximum allowed.

Voltage imbalance

The maximum allowable voltage imbalance between each phase is 3%. Voltage imbalance causes high amperage over one or several phases, which in turn leads to overheating and possible drive damage.

Mains imbalance function in CDS frequency converter can be set to “[0] Trip” or “[1] Warning”

in 14.12 parameter. It is, by default, factory preset to “[1] Warning”.

Then the compressor electrical motor is never affected by main voltage imbalance situations which are made completely transparent by the frequency converter.

Approval and certificates

Approvals and certificates

VLZ compressors comply with the following approvals and certificates.

CE (European Directive)		VLZ code G & code J
UL (Underwriters Laboratories)		All VLZ models
EMC 2014/30/EU		VLZ code G & code J
CCC		VLZ code G

Conformity to directives

Pressure equipment directive 2014/68/EU
Machinery directive 2006/42/EC annex II b

Low voltage directive 2014/35/EU
Electromagnetic compatibility 2014/30/EU

Products	VLZ028-035-044
Refrigerating fluids	Group 2
Category PED	I
Evaluation module	no scope
Service temperature - Ts	-35°C < Ts < 55°C
Service pressure (low side) - Ps	26.17 bar(g)
Declaration of conformity	contact Danfoss
Marking of conformity	CE

Internal free volume

Products	Internal free volume at LP side without oil (liter)
VLZ028	3.2
VLZ035	3.2
VLZ044	3.2

GENERAL INFORMATION

PRODUCT INFORMATION

SYSTEM DESIGN

INTEGRATION INTO SYSTEM

ORDERING INFORMATION

General requirements

Proper piping practices should be employed to:

1. Ensure adequate oil return, even under minimum load conditions (refrigerant speed, piping slopes...). For more details see section "Manage oil in the circuit".

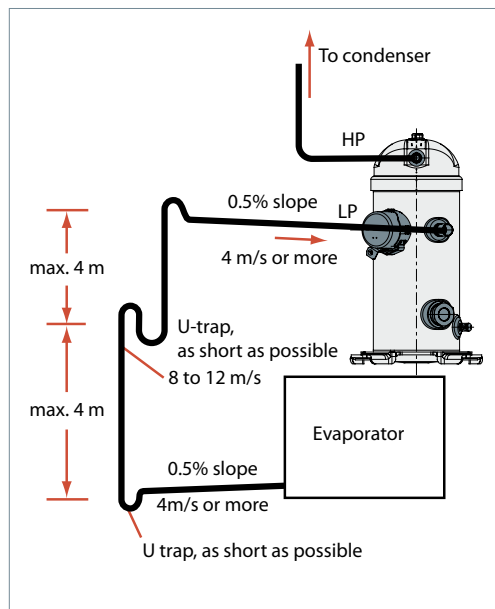

3. Piping should be designed with adequate three-dimensional flexibility to avoid excess vibration. It should not be in contact with the surrounding structure, unless a proper tubing mount has been installed. For more information on noise and vibration, see section on: "Sound and vibration management".

2. Avoid condensed liquid refrigerant from draining back to the compressor when stopped (discharge piping upper loop). For more details see section "Manage off cycle migration".

General recommendations are described in the figures below:

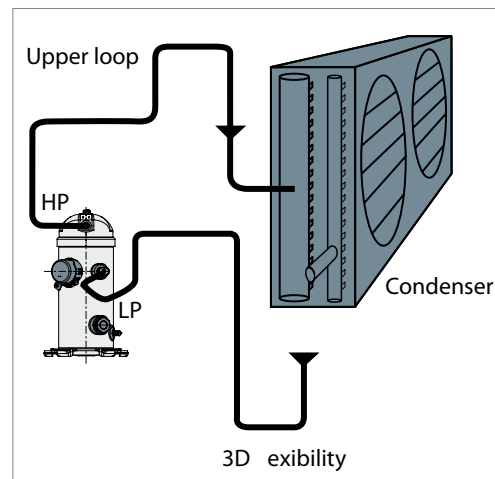

4. The design in this guideline is for short circuit application. However, for long circuit and split system application, an oil separator and an external non-return valve are mandatory to use.

Design compressor mounting

General requirements

Compressors used in single applications must be mounted with flexible grommets.

During operation, the maximum inclination from the vertical plane must not exceed 7 degrees.

Single requirements

All compressors are delivered with four rubber grommets and metal sleeves. Compressors must always be mounted with these grommets. Recommended torque for mounting bolts: 11 Nm (± 1 Nm).

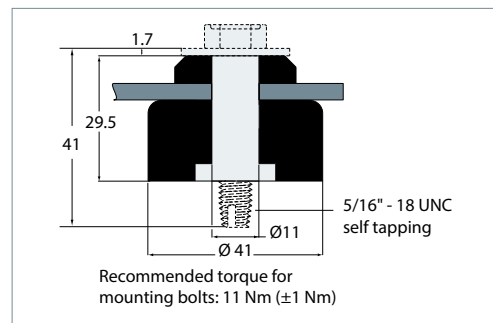

GENERAL INFORMATION

PRODUCT INFORMATION

SYSTEM DESIGN

INTEGRATION INTO SYSTEM

ORDERING INFORMATION

Manage oil in the circuit

Requirement

R Oil level must be visible or full in the sight glass when the compressor is running and when all compressors of the circuit are stopped.

System evaluation

	Single compressor
Non split	Oil return test described below
Split	<ol style="list-style-type: none"> 1. Since each installation is unique, test can not validate the oil return, Oil separator* is mandatory 2. Pay special attention to "Piping design" on field 3. Oil level must be checked and adjusted at commissioning.

Test, criteria and solutions

Purpose	Test condition	Pass criteria	Solutions
Check proper oil return	 Lowest foreseeable evaporation, and highest foreseeable condensation. Minimum speed during 6 hours.	Oil level must be visible or full in the sight glass when the compressor is running.	<ol style="list-style-type: none"> 1. Top-up with oil, generally 3% of the total system refrigerant charge (in weight). Above 1-2% look for potential oil trap in the system. 2. Adjust oil boost function, for more details see section "Oil management logic". 3. Oil separator* can be added

*Oil separator

Oil separator which has the internal reintegration system is recommended, such as floating ball oil separator.

Oil return injection **must be done in suction line** and not in oil sump. If there is a suction accumulator, place the oil return on suction pipe, between suction accumulator and compressor suction port.

In any case, the T° measurement used for superheat control, (bulb or sensor) must be placed before the oil injection.

NRV must be used at outlet of oil separator to prevent Compressor Off Cycle migration issues.

Do not place the oil separator in the air flow, to avoid having oil separator acting as a condenser.

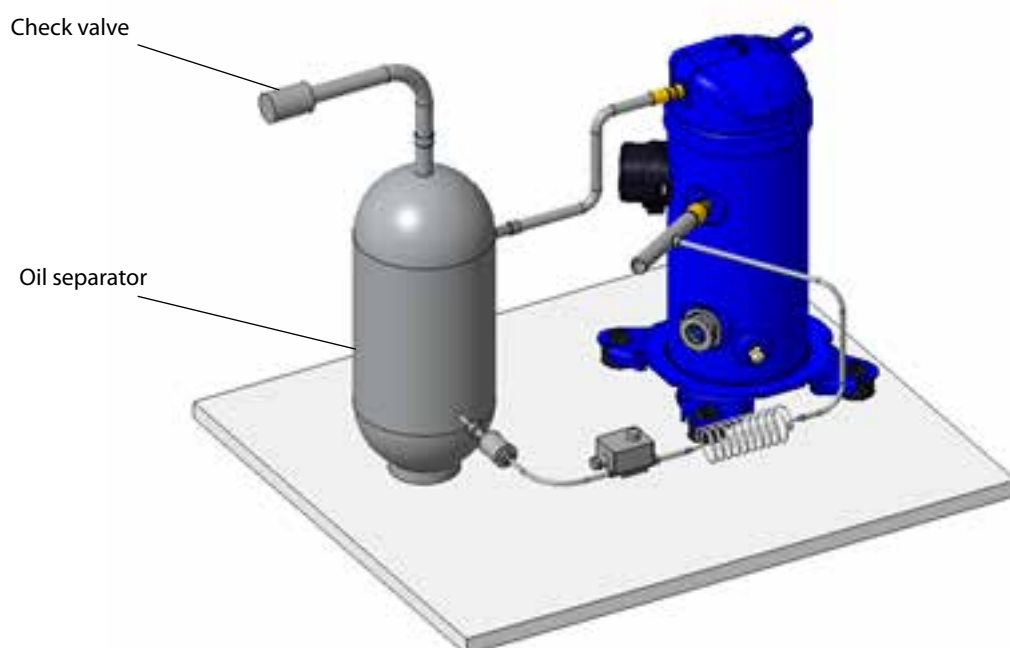

GENERAL INFORMATION

Compressor sound radiation

Typical sounds and vibrations in systems can be broken down into the following three categories:

- Sound radiation (through air)
- Mechanical vibrations (through parts and structure)

• Gas pulsation (through refrigerant)
The following sections focus on the causes and methods of mitigation for each of the above sources.

For sound radiating from the compressors, the emission path is air and the sound waves are travelling directly from the machine in all directions.

Sound levels are as follows:

• For compressors running alone:

Compressor model	Frequency RPS	200V		400V		Acoustic hood code number
		Sound power dB(A)	Attenuation dBA ①	Sound power dB(A)	Attenuation dBA ①	
VLZ028-035-044	60	77	7	77	7	120Z5083
	100	86	7	86	7	

Sound power and attenuation are given at EN conditions, measured in free space

Please notice below two phenomenon is also normal for variable speed compressor:

1. At light load and low speed condition the compressor may produce certain discharge pulsation.

2. In some situations when the compressor stops working, there may still be some noise which lasts around 2 seconds. The electro-magnetic noise is caused by drive anti-reverse protection.

① Attenuation given with acoustic hood

Materials are UL approved

During compressor shut down, a short reverse rotation sound is generated. The duration of this sound depends on the pressure difference at shut down and should be less than 3 seconds. This phenomenon has no impact on compressor reliability.

Danfoss as accessories. Refer to the table above for sound levels, attenuation and code numbers.

2. Use of sound-insulation materials on the inside of unit panels is also an effective means to reduce radiation.

Mitigations methods:

We can consider two means to reduce compressors sound radiations:

1. Acoustic hoods are quick and easy to install and do not increase the overall size of the compressors. Acoustic hoods are available from

Note: During compressor shut down, a short reverse rotation sound is generated. The duration of this sound depends on the pressure difference at shut down and should be less than 3 seconds. This phenomenon has no impact on compressor reliability.

PRODUCT INFORMATION

SYSTEM DESIGN

INTEGRATION INTO SYSTEM

ORDERING INFORMATION

Manage sound and vibration

Mechanical vibrations

A compressor generates some vibrations that propagate into the surrounding parts and structure. The vibration level of a VLZ compressor alone does not exceed 76 µm peak to peak. However, when system structure natural frequencies are close to running frequency, vibrations are amplified due to resonance phenomenon.

A high vibration level is damageable for piping reliability and generates high sound levels.

Mitigations methods:

1. Danfoss VLZ scroll compressors are designed to produce minimal vibration during operations. To ensure minimum vibrations transmission to the structure, strictly follow mounting requirements (mounting feet, rails etc.). For further information on mounting requirements, please refer to "Design compressor mounting".
2. Ensure that there is no direct contact (without insulation) between vibrating components and structure.
3. Resonance phenomenon
To avoid resonance phenomenon, pipings and frame must have natural frequencies as far as possible from running frequencies.

This could be challenging on a variable system as all resonant frequencies between min speed to maximum speed will be exited.

It is mandatory to check that piping vibrations are acceptable across speed range. This test can be done by increasing slowly speed and monitoring piping behavior through, strain gage, acceleration, or displacement measurement. As alternative visual check with strobe light can also emphasis high piping displacement.

If some resonant frequencies generate high piping vibration, problem can be solved by increasing piping stiffness with brackets or changing layout. Dampers can also be installed to mitigate vibration.

If some frequencies continue to produce unacceptable vibration levels, speed by-pass is adjustable in the frequency converter, in order to avoid some frequency ranges. Four by-pass ranges are adjustable, and settings can be made in parameter group 4-6.

Gas pulsation

The Danfoss VLZ scroll compressor has been designed and tested to ensure that gas pulsation is optimized for the most commonly encountered air conditioning pressure ratio. Manifoldded compressors are equivalent to lagged sources of gas pulsation. Therefore, pulse level can vary during time.

Mitigations methods:

If an unacceptable level is identified, a discharge muffler with the appropriate resonant volume and mass can be installed.

Manage operating envelope

Requirement

R The operating envelope for VLZ scroll compressors is given in the figures below and guarantees reliable operations of the compressor for steady-state and transient operation.

Moreover, the discharge gas temperature must not exceed 135°C. A suction superheat below 5 K is not recommended due to the risk of liquid flood back.

Single application envelop

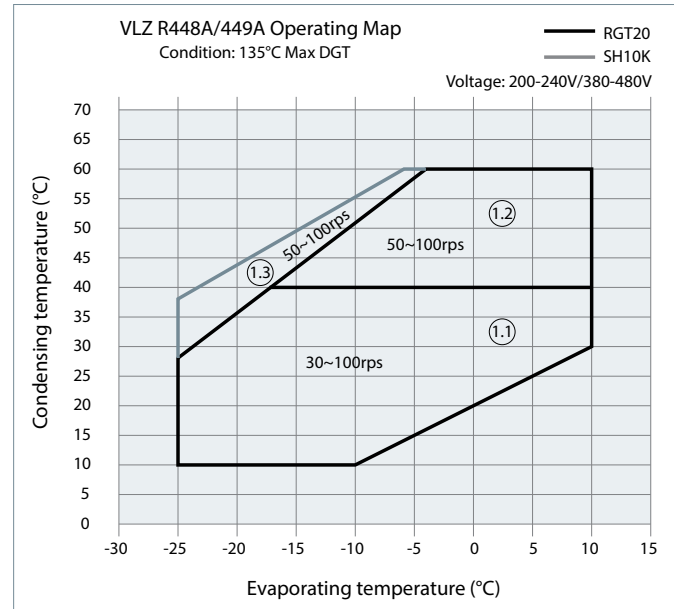
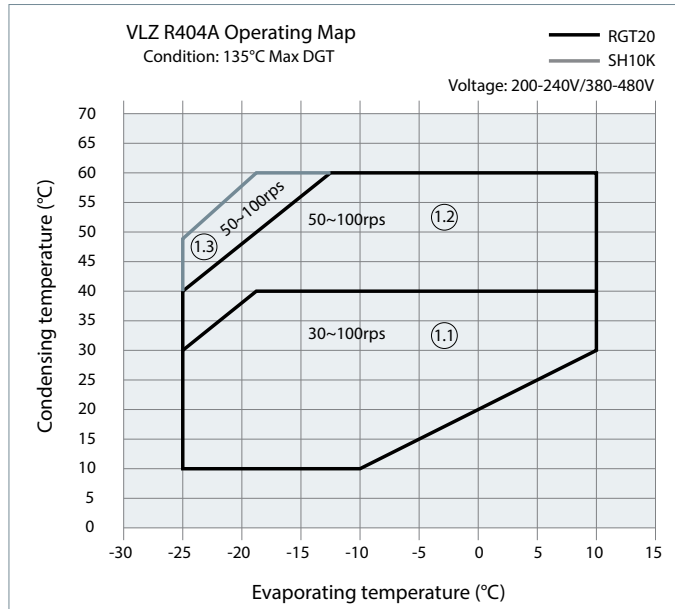

Pressure settings		R404A	R448A/R449A
Working range high side	bar(g)	7.2-27.7	6.1-26.0
Working range low side	bar(g)	1.5-7.2	1.0-6.2
Maximum high pressure safety switch setting*	bar(g)	29.7	27.4
Minimum low pressure safety switch setting	bar(g)	1.3	0.8
Minimum low pressure pump-down switch setting**	bar(g)	1.6	1.1

*Maximum allowable pressure on high pressure side according to PED regulation.

**Recommended pump-down switch settings: 1.5 bar below nominal evap. Pressure with minimum of 1.8bar(g)

System evaluation

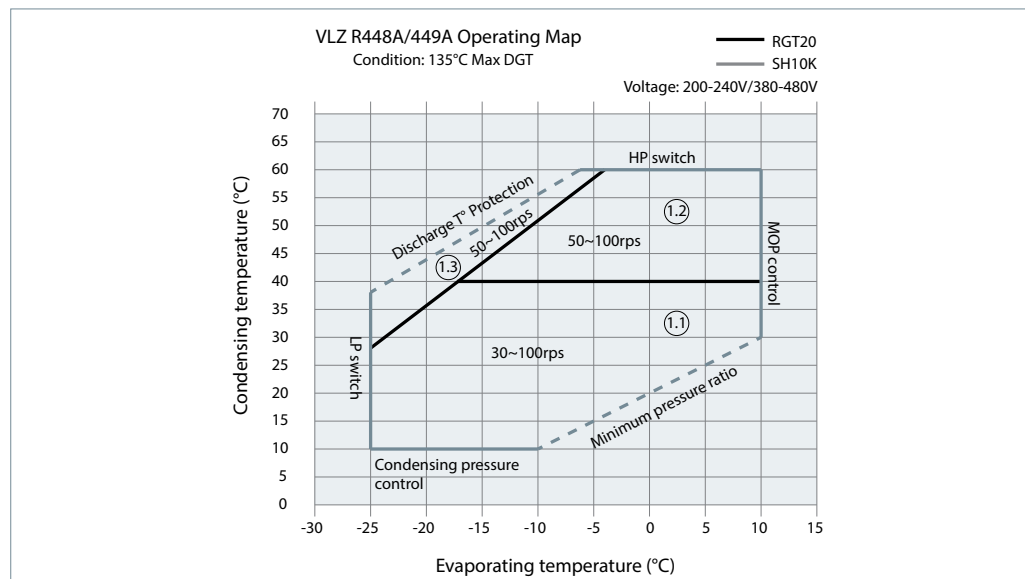

Manage operating envelope

High and low pressure protection

R Low-pressure (LP) and high-pressure (HP) safety switches must never be bypassed nor delayed and must stop all the compressors.

LP switch auto restart must be limited to 5 times within 12 hours.

! HP safety switch must be manual reset

Depending on application operating envelope, you must define HP and LP limits within operating envelope and pressure setting table above.

High pressure protection

The high-pressure switch must be defined at a lower pressure than setting table above.

If a discharge valve is used, the HP switch must be connected to the service valve gauge port, which must not be isolated.

More details see (for more details see "Control Logic").

Low pressure protection

The high-pressure switch must be defined at a higher pressure than setting table above. (for more details see "Control Logic")

Discharge temperature protection

Continuous operations beyond the max discharge T° will cause serious damage to the compressor. The compressor must not be allowed to cycle on the discharge gas thermostat

The discharge gas thermostat accessory kit (code 7750009) includes all components required for installation as shown on the right. DGT installation must respect below requirements:

- The thermostat must be attached to the discharge line within 150 mm from the compressor discharge port and must be thermally insulated and tightly fixed on the pipe.

- The DGT should be set to open at a discharge gas temperature below 135°C.

Complementary to DGT protection the unit controller can decrease compressor speed to decrease condensing T° and thus decrease discharge gas T°

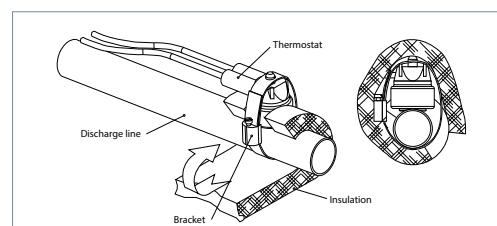

MOP control

In steady state, it essential to prevent compressor running in evaporating T° higher than specifier in envelope. This can be done by using MOP

function on expansion device. Complementary to MOP, the unit controller can increase compressor speed to keep evaporating T° lower than limit.

Condensing pressure control

In steady state, the condensing T° must be maintained at a higher T° than specified in envelope. This can be done by using fan speed controller, or constant pressure valve. Keep condensing pressure at a minimum level is also important to maintain the pressure differential across the thermostatic expansion valve and

prevent cut out on the LP protection in cold ambient.

As an alternative the unit controller can increase compressor speed to keep condensing T° lower than limit.

Minimum pressure ratio

In steady state, the pressure ratio must be a higher T° than specified in envelope. 2 type of control can be considered:

- Set the minimum condensing T° at 30°C together with MOP set at 10°C.

- Unit controller monitors permanently Condensing and Evaporating T°, and adjust compressor speed or condensing T° to keep running conditions within envelope.

Speed range control

Depending on speed range needed, two type of controls to be considered

- Speed range limited from 50rps to 100rps; Single envelope control, no specific requirement.

- Speed range limited from 30 to 100rps, Multiple envelope control, Condensing and Evaporating T° must be permanently monitored, and unit controller must ensure that compressor speed will not be lower than 50rps in area 1.1 and 1.3

Manage speed limit

Speed limit requirement

R Speed limit guarantees compressor reliability and must be respect. In drive control logic, default setting values have been qualified

by Danfoss. It is not recommended to change from default value.

Start/Stop/Ramp setting

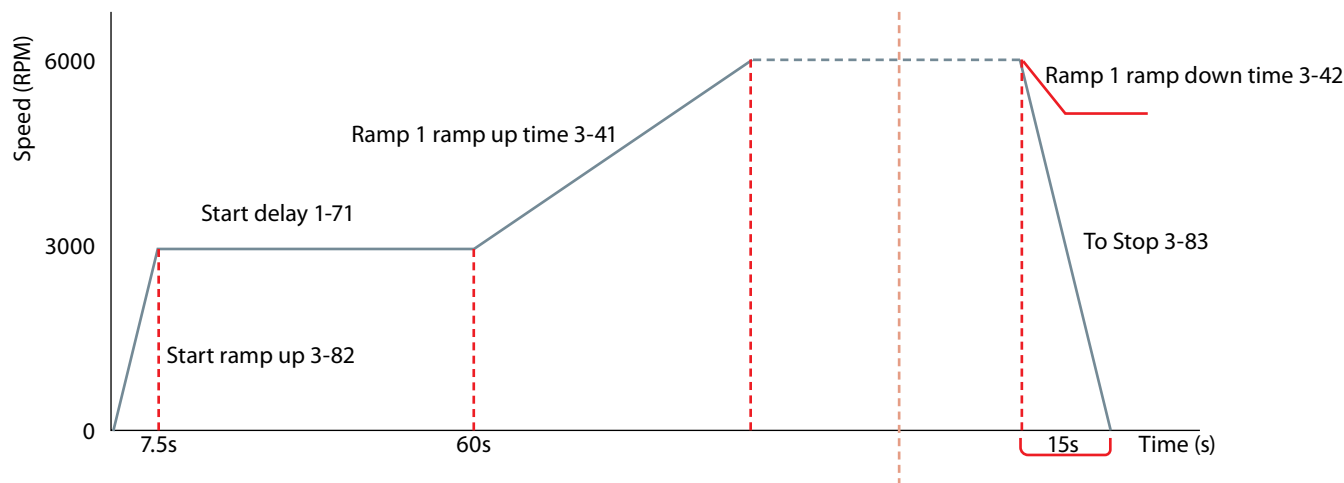

Drive parameter	Data range	Description	Default value(s)
3-82	Start ramp up	0.01-3600 Start compressor at within a certain duration from 0rpm to 6000rpm ramp up Eg: The default value 15s is set for speed increase from 0rpm to 6000rpm. if start the compressor from 0-3000s, then it will take 7.5s.	15
1-71	Start delay	0-120 keep running @ 3000 RPM within a certain duration	60
3-41	Ramp 1 ramp up time	15-3600 It is used to define speed ramp up slope. Speed ramp up slope is defined under condition that increases compressor speed from 0 rpm to 6000 rpm in a certain period(s, ramp1 ramp up time) Eg: if current speed is 3000rpm and desired speed is 4000rpm, then compressor will reach 4000 rpm in 15s	90
3-83	To Stop	0.01-3600 Stop the compressor in a speed that is defined under condition decrease from 6000rpm to 0rpm within a certain duration(default value is 15s)	15
3-42	Ramp 1 ramp down time	15-3600 It is used to define speed ramp down slope. Speed ramp down slope is defined under condition that decreases compressor speed from 6000 rpm to 0rpm in a certain period (s, ramp1 ramp down time) Eg: if current speed is 4000rpm and desired speed is 3000rpm, then compressor will reach 3000 rpm in 5s	30

Manage speed limit

Short cycle protection

The CDS803 drive software includes a compressor short cycling protection that prevents the compressor from starting and stopping too often

The short cycle protection consist of two timers:

- The interval between starts ensures that a new start first become active when the start timer has expired
- The minimum run time ensures that the compressor always runs a minimum define time before stopping the compressor

Drive parameter	Data range	Description	Default value(s)	Acceptable range	
28-00	Short cycle protection	Enabled/Disabled	Parameter for enabling short cycle protection functions	Enabled	-
28-01	Interval between starts	60-3600	Minimum value allowed to set	300	30-120
28-02	Minimum run time	0-300	Minimum value allowed to set	12	30-3600

Manage superheat

During normal operation, refrigerant enters the compressor as a superheated vapor. Liquid flood back occurs when a part of the refrigerant entering the compressor is still in liquid state.

Liquid flood back can cause oil dilution and, in extreme situations lead to liquid slugging that can damage compression parts.

Requirement

In steady state conditions,
 • the expansion device must ensure a suction superheat above 5k.

System evaluation

Use table below to define necessary test and safety required

Package	Split	Defrost**	Suction accumulator*	Test
X			Optional	Pass liquid flood back test
	X		Mandatory	No
		X	Mandatory	No

*Suction accumulator offers protection by trapping the liquid refrigerant upstream from the compressor. The accumulator should be sized at least 50 % of the total system charge. Suction accumulator dimensions can impact oil return (gas velocity, oil return hole size...), therefore oil

return has to be checked according to section "Manage oil in the circuit".

**System perform defrost by any mean (hot gas, electrical, reverse cycle)

GENERAL INFORMATION

PRODUCT INFORMATION

SYSTEM DESIGN

INTEGRATION INTO SYSTEM

ORDERING INFORMATION

Manage superheat

Test, criteria and solutions

Test N°	Purpose	Test condition	Pass criteria	Solutions
Liquid flood back test	Steady-state	Liquid flood back testing must be carried out under expansion valve threshold operating conditions: •Lowest foreseeable evaporation, and highest foreseeable condensation. •Minimum speed	Suction superheat >5K	1. Check expansion valve selection and setting. -For Thermostatic expansion valve (TXV) check bulb position... -For Electronic expansion valve (EXV) check measurement chain and PID.... 2. Add a suction accumulator*.
	Transient	Tests must be carried out with most unfavorable conditions : • fan staging, • compressor staging	Oil superheat shall not be more than 30 sec below the safe limit defined in the Dilution Chart. (see graph below)	

Oil temperature sensor must be placed between oil sight glass and compressor baseplate. Some thermal paste shall be used to improve the conductivity. The sensor must also be correctly thermally insulated from the ambience.

The Oil superheat is defined as:
 (Oil temperature - Evaporating temperature)

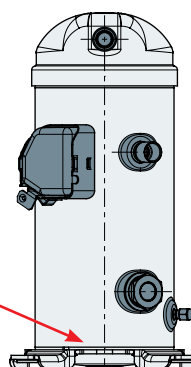

Dilution Chart

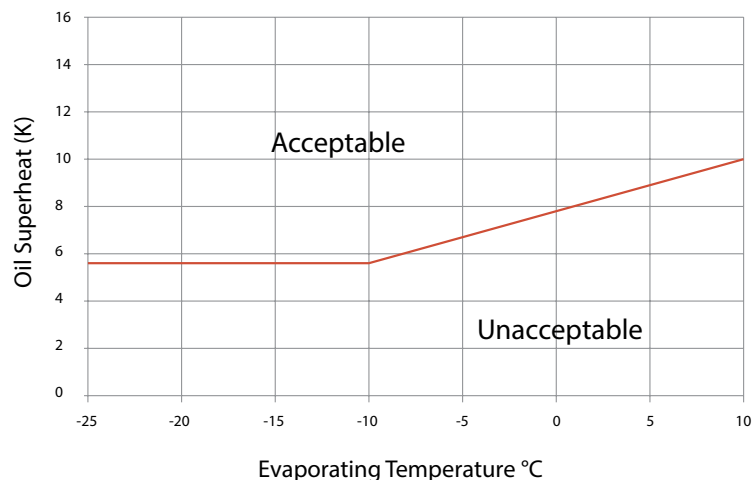

Manage off cycle migration

- R** Off -cycle refrigerant migration happens:
- when the compressor is located at the coldest part of the installation, refrigerant vapor condenses in the compressor.
 - or directly in liquid-phase by gravity or pressure difference.

When the compressor restarts, the refrigerant diluted in the oil, or stored in evaporator, generates poor lubrication conditions, and may reduce bearings life time. In extreme situations, this leads to liquid slugging that can damage the compressor scroll set.

Requirement

- Compressor can tolerate occasional flooded start, but it should remain exceptional situation and unit design must prevent that this situation happen at each start.
- Right after start, liquid refrigerant must not flow massively to compressor
- The charge limit is a threshold beyond some protective measures must be taken to limit risk of liquid slugging and extreme dilution at start.

System evaluation

Use the table below in relation with the system charge and the application to quickly define necessary safeties to implement.

Application	BELOW charge limit	ABOVE charge limit
All	Ensure tightness between condenser & evaporator when system is OFF • Thermostatic expansion Valve (TXV) , Liquid Line Solenoid Valve LLSV** mandatory • Electronic expansion valve (EXV) must close when system stop including in power shut down situation	
Non split	No test or additional safeties required	• Surface Sump Heater * • External Non-Return Valve ****
Split	Since each installation is unique, refrigerant charge may vary • Surface Sump Heater * • Liquid Line Solenoid Valve**+ pump-down cycle*** • External Non-Return Valve	

Charge limit is defined in table below:

	Models	Refrigerant charge limit (kg)
Single	VLZ028-035-044	3.6

GENERAL INFORMATION
 PRODUCT INFORMATION
 SYSTEM DESIGN
 INTEGRATION INTO SYSTEM
 ORDERING INFORMATION

*Crankcase heater

The belt crankcase heaters are designed to protect the compressor against off-cycle migration of refrigerant.

Additional heater power or thermal insulation might be needed in case of ambient temperature below -5°C and a wind speed above 5m/second. The heater must be turned on whenever all the compressors are off.

Crankcase heater accessories are available from Danfoss (see section "Accessories").

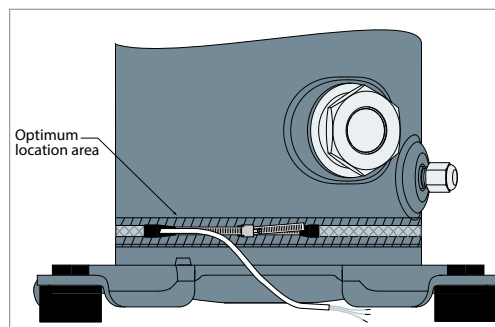

**Liquid line solenoid valve (LLSV)

A LLSV is used to isolate the liquid charge on the condenser side, thereby preventing against charge transfer to the compressor

during off -cycles. The quantity of refrigerant on the low-pressure side of the system can be further reduced by using a pump-down cycle in association with the LLSV.

***Pump-down cycle

By decreasing pressure in the sump, pump down:

- Evacuates refrigerant from oil
- Set the sump saturating pressure much lower than ambience temperature and due to that, avoid refrigerant condensation in the compressor.
- Pump-down must be set higher than 1.8 bar(g).

For more details on pump-down cycle see section "Control Logic".

Provide power supply and electrical protection

EMC correct installation of an frequency drive CDS803

EMC qualification reports are available upon request to Danfoss technical support.

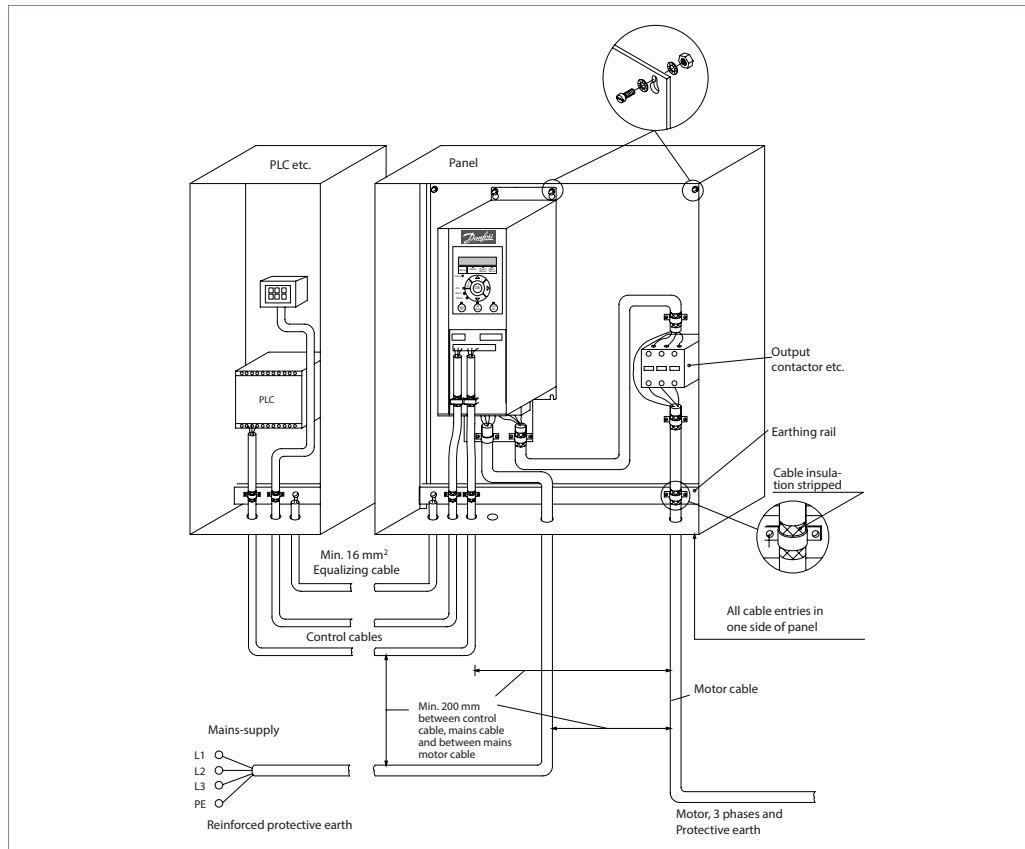

Wiring diagram of CDS803

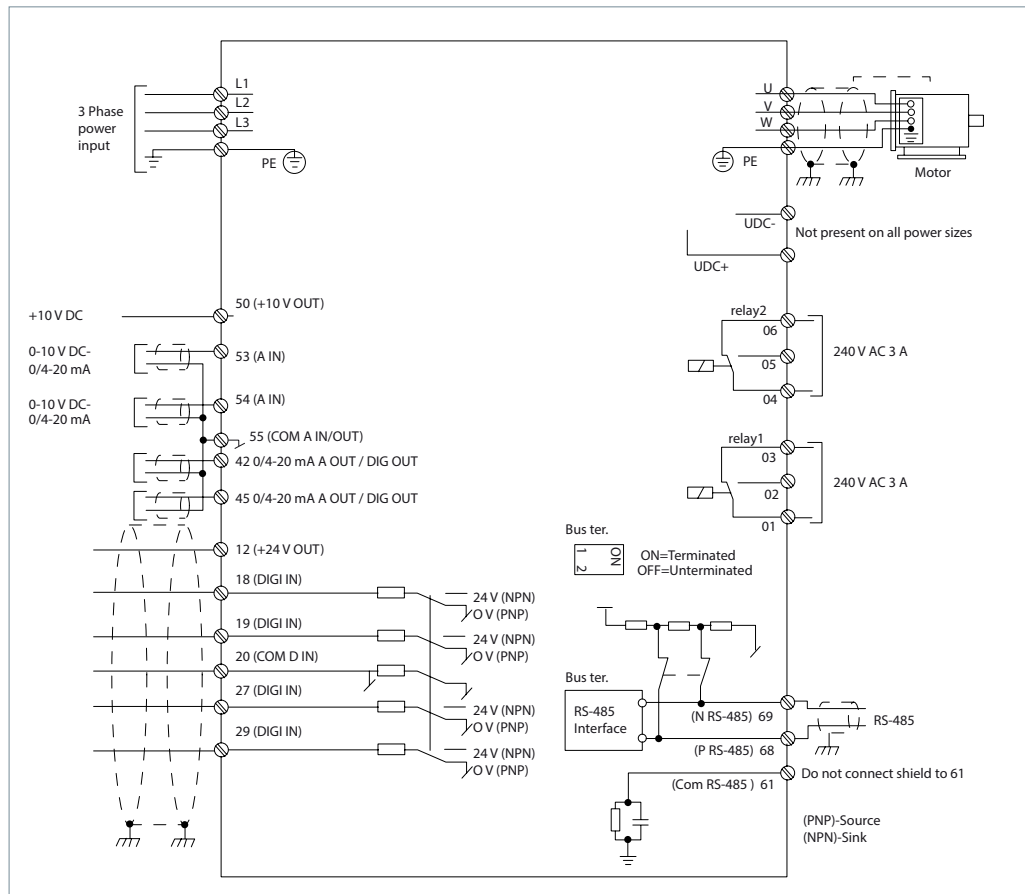

Provide power supply and electrical protection

Wiring connections of CDS803

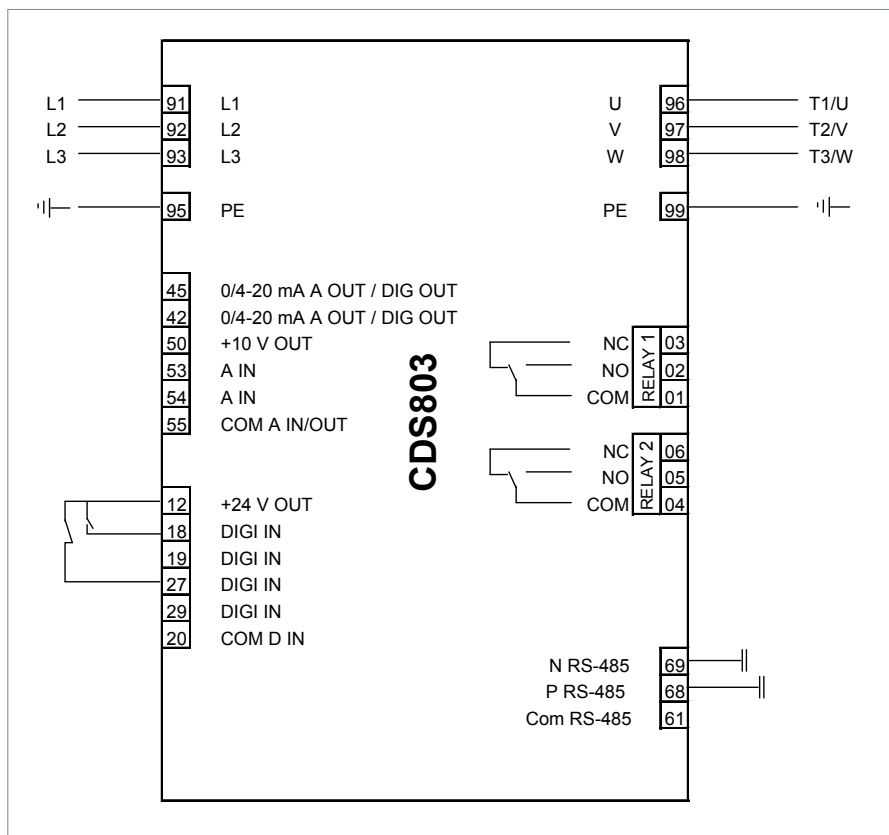

Legends:

A:	Analog
DIGI:	Digital
IN:	Input
OUT:	Output
COM:	Common
NC:	Normally-closed
NO:	Normally-open

		Open loop	Process loop
91,92,93	3 phases mains input	x	x
95	Earth	x	x
42,45	0/4-20 mA Analogue Output or Digital Output	-	-
50	+10V DC Output	-	-
53	0-10V or 4-20mA Analogue Input	x	-
54	0-10V or 4-20mA Analogue Input	-	x
55	Com Analogue In/Out	x	-
12	+24V output	-	-
18	External On/Off(NO)	x	x
19	Digital Input	-	-
27	Safety Device e.g.: HP/LP switch	x	x
29	Digital Input	-	-
20	Com Digital Input	-	-
98	To Compressor T3	x	x
97	To Compressor T2	x	x
96	To Compressor T1	x	x
99	Earth	x	x
03,02,01	Relay 1	-	-
06,05,04	Relay 2	-	-
69,68	RS485 Bus	-	-
61	RS485 Bus Com	-	-

-: Optional connection
X: Mandatory connection

The CDS803 frequency converter is factory preset with parameters for the open loop control principle. The process loop control principle can be selected by changing parameters in the "Quick menu."

Open loop: preset on input 53

0 - 10 V control

Frequency converter in slave mode

Process loop: preset on input 54

4 - 20 mA control

Frequency converter under own PID controller

Soft-start control

The CDS803 frequency converter generates by design a compressor soft start with a default initial ramp up of 7.5s to 50 rps.

Current inrush will not exceed the frequency converter maximum current.

Basically seen from the mains the inrush peak reach a level which is only a few percent more than the rated nominal current.

Control logic

Safety control logic requirements

	Tripping conditions		Re-start conditions	
	Value	Time	Value	Time
HP switch	See Pressure settings table from section "Manage operating envelope"	Immediate, no delay. No by-pass	Conditions back to normal. Switch closed again	Manual reset
LP safety switch				Maximum 5 auto reset during a period of 12 hours, then manual reset.

High pressure

According to EN378-2, a high-pressure (HP) safety switch is required to shut down the compressor. If a discharge valve is used, the HP switch must be connected to the service valve gauge port, which must not be isolated. The HP switch must be connected to the CDS803 input 27 or an external contactor placed before and after the drive.

Please note port 27 of CDS803 is not UL certificated and when connected with high pressure switch, no delay is permitted. Set port 27 to "coast inverse or external interlock" to get rid of minimum running time restriction.

Low pressure

LP switch must be connected to CDS803 input 27. OEM need to set port 27 to "coast inverse or

external interlock" to get rid of minimum running time restriction.

Electronic expansion valve

With variable capacity systems, an electronic expansion valve (EXV) is strongly recommended to handle refrigerant mass flow variations.

Ramp-down of the EXV must be shorter than the ramp-down of the compressor, to avoid liquid floodback to compressor.

Ramp-up of the EXV must be shorter than the ramp-up of the compressor, to avoid any low pressure operation on suction side of the compressor. The EXV can also be opened, up to a certain degree, before the start up of the compressor.

In case of cyclic expansion device (Danfoss AKV type) the cycle time must be long enough to avoid any low pressure operation on suction side of compressor

EXV should be closed, and remain closed, when the compressor is off, to avoid any liquid refrigerant entering the compressor.

GENERAL INFORMATION

PRODUCT INFORMATION

SYSTEM DESIGN

INTEGRATION INTO SYSTEM

ORDERING INFORMATION

Control logic

Defrost cycle logic

In refrigeration system applications, there are different defrost methods, such as electric heating defrost, hot gas bypass defrost, reversible defrost etc. For the systems which use hot gas bypass or reversible defrost method, suction accumulator is necessary as a result of the possibility of a substantial quantity of liquid refrigerant remaining in the evaporator.

This liquid refrigerant can then return to the compressor, either flooding the sump or as a dynamic liquid slug when the cycle switch back to normal cooling operations. Sustained and repeated liquid slugging and flooding can seriously impair the oil's ability to lubricate the compressor bearings. In such cases a suction accumulator is a must.

Pump-down logic recommendations

Pump down is initiated prior to shutting down the last compressor on the circuit by de-energizing a liquid line solenoid valve or closing electronic expansion valve. When suction pressure reached the cut-out pressure, compressor is stopped, and liquid solenoid valve or electronic expansion valve remains closed. Two types of pump-down exist:

- One shot pump down (preferred): when last compressor of the circuit stops, suction pressure is decreased 1.5 bar below nominal evaporating pressure. Even if suction pressure increases again, the compressor will not restart.
- Continuous pump-down: traditional pump-down, Compressor restarts automatically when suction pressure increases up to 4 cycles maximum. A non-return valve in the discharge line is recommended.

Oil management logic

Due to large capacity range of variable speed system, it is often a challenge to ensure a proper oil return to compressor at low speed. CDS803 integrates oil return management(ORM) function that automatically raise compressor speed if it has run for a long period in low speed. For split system this function complementary to oil separator.

This function is enabled by default but can be disabled and managed directly by unit controller.

- If compressor run below 2400 rpm for more than 120 minutes (low speed running time, 28-11), oil boost function accelerates compressor speed to 3600 rpm for 1 minute* to take the oil back from system.

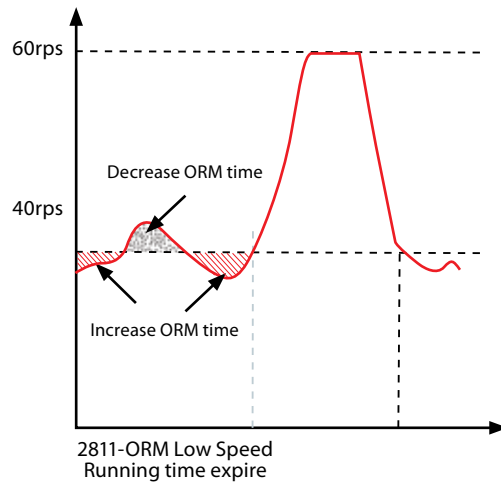

This function uses a timer:

The timer is set at par. low speed running time 28.11, 120min.

When actual compressor speed is below 40rps, the timer is increasing. When compressor speed is above 40rps timer is decreasing.

When time counter reach 120min the oil return boost is started.

When the boost is terminated, the compressor speed goes back to run on reference (speed setpoint) and the time counter is reset and restarting from zero.

- To double ensure oil return from system, compressor speed will boost to 3600 rpm

at a fixed time intervals (as programmed in parameter 28-12, default 24 hrs) any way.

ID	Name	Factory Setup	Unit	Customer Access	Valve Range
2810	Oil Return Management	Enable		R/W	Enable/Disable
2811	Low Speed Running Time	120	min	R/W	1-120
2812	Fixed Boost Interval	24	h	R/W	1-168
2813	Boost Duration	60	s	R/W	60-300

GENERAL INFORMATION
PRODUCT INFORMATION
SYSTEM DESIGN
INTEGRATION INTO SYSTEM
ORDERING INFORMATION

Reduce moisture in the system

	<p>Excessive air and moisture</p> <ul style="list-style-type: none"> • can increase condensing pressure and cause excessively high discharge temperatures. • can create acid giving rise to copper plating. • can destroy the lubricating properties of the oil. 	<p>All these phenomena can reduce service life and cause mechanical and electrical compressor failure.</p>
Requirements	<p>VLZ compressors are delivered with < 100 ppm moisture level. At the time of commissioning, system moisture content may be up to 100 ppm.</p>	<p>During operation, the filter drier must reduce this to a level between 20 and 50 ppm.</p>
Solutions	<p>To achieve this requirement, a properly sized and type of drier is required. Important selection criteria's include:</p> <ul style="list-style-type: none"> • driers water content capacity, • system refrigeration capacity, • system refrigerant charge. 	<p>For new installations with VLZ compressors with POE oil, Danfoss recommends using the Danfoss DML (100% molecular sieve) solid core filter drier.</p>

Assembly line procedure

Compressor storage

Store the compressor not exposed to rain, corrosive or flammable atmosphere between -35°C and 70°C when charged with nitrogen and

between -35°C and 55°C when charged with R404A/448A/449A refrigerant.

Compressor holding charge

Each compressor is shipped with a nominal dry nitrogen holding charge between 0.3 and 0.7 bar and is sealed with elastomer plugs.

- ⚠ Respect the following sequence:
 - Remove the nitrogen holding charge via the suction Schrader valve to avoid an oil mist blow out.

- Remove the suction plug first and the discharge plug afterwards to avoid discharge check valve gets stuck in open position. An opened compressor must not be exposed to air for more than 20 minutes to avoid moisture is captured by the POE oil.

Handling

- ⚠ Each Danfoss VLZ scroll compressor is equipped with one lift ring on the top shell.
- Always use one lift ring and discharge tube when lifting the compressor.
- Use lifting equipment rated and certified for the weight of the compressor or compressor assembly.
- A spreader bar rated for the weight of the compressor is highly recommended to ensure a better load distribution.

- The use of lifting hooks closed with a clasp is recommended.
- Never use the lift rings on the compressor to lift the full unit.

Maintain the compressor in an upright position during all handling manoeuvres (maximum of 15° from vertical).

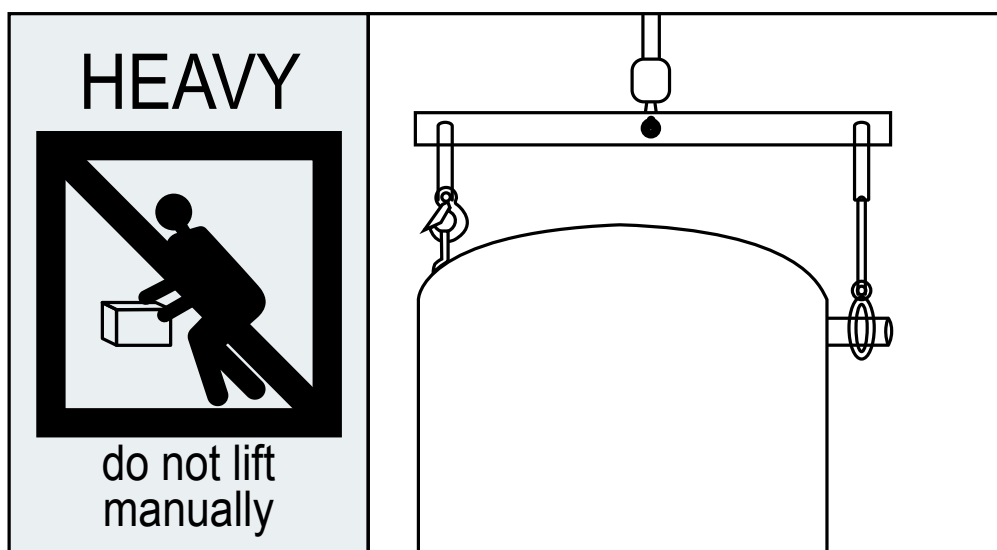

GENERAL INFORMATION

PRODUCT INFORMATION

SYSTEM DESIGN

INTEGRATION INTO SYSTEM

ORDERING INFORMATION

Piping assembly

Good practices for piping assembly is a pre-requisite to ensure compressor service life (system cleanliness, brazing procedure...)

System cleanliness

Circuit contamination possible cause	Requirement
Brazing and welding oxides	During brazing, flow nitrogen through the system
Filings and particles from the removal of burrs in pipe-work	Remove any particles and burrs generated by tube cutting and hole drilling
Moisture and air	Use only clean and dehydrated refrigeration grade copper tubing Opened compressor must not be exposed to air more than 20 minutes to avoid moisture captured by POE oil.

Brazing procedure:

- Brazing operations must be performed by qualified personnel.
- Make sure that no electrical wiring is connected to the compressor.
- To prevent compressor shell and electrical box overheating, use a heat shield and/or a heat-absorbent compound.
- Clean up connections with degreasing agent
- Flow nitrogen through the compressor.
- Use flux in paste or flux coated brazing rod.

- Use brazing rod with a minimum of 5% silver content.
- It is recommended to use double-tipped torch using acetylene to ensure a uniform heating of connection.
- To enhance the resistance to rust, a varnish on the connection is recommended.

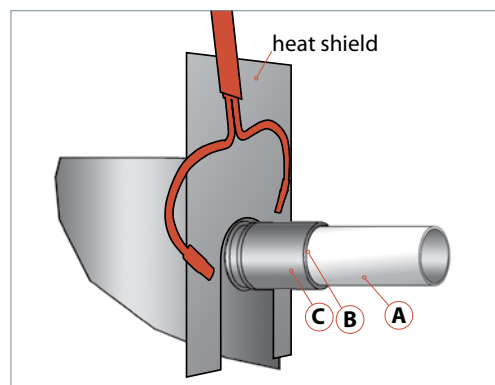

! Before eventual un-brazing of the compressor or any system component, the refrigerant charge must be removed.

System pressure test and leak detection

- !** The compressor has been strength tested and leak proof tested (<3g/year) at the factory. For system tests:
- Always use an inert gas such as Nitrogen or Helium.

- Pressurize the system on HP side first then LP side.
- Do not exceed the following pressures:

Maximum compressor test pressures	
Maximum compressor test pressure high side (HP)	41.1 bar (g) HP-LP<36bar
Maximum compressor test pressure low side (LP)	30 bar (g) LP-HP<5bar Maximum speed 4,8 bar/ second*

* If an external non return valve is present on the discharge line, maximum pressurizing speed must be respected to ensure pressure equalization between LP and HP side over scroll elements.

GENERAL INFORMATION

Vacuum evacuation and moisture removal

Requirements:

- Never use the compressor to evacuate the system.
- Connect a vacuum pump to both the LP and HP sides.
- Evacuate the system to a pressure of 500 µm Hg (0.67 mbar) absolute.

Recommendations:

- Energized heaters improve moisture removal.
- Alternate vacuum phases and break vacuum with Nitrogen to improve moisture removal.

For more detailed information see "Vacuum pump-down and dehydration procedure" TI-026-0302.

PRODUCT INFORMATION

Refrigerant charging

Initial charge:

- For the initial charge, the compressor must not run.
- Charge refrigerant as close as possible to the nominal system charge.
- This initial charging operation must be done in liquid phase between the condenser outlet and the filter drier.

- If needed, a complement of charge can be done:
- In liquid phase while compressor is running by slowly throttling liquid in.
 - Never bypass safety low pressure switch.

For more detailed information see "Recommended refrigerant system charging practice" FRCC.EN.050.

SYSTEM DESIGN

Dielectric strength and insulation resistance tests

The tests are performed on each compressor at the factory between each phase and ground.

- Carry out a dielectric strength test by short-circuiting terminals L1, L2 and L3. Energize by max. 1920 V DC (hi-pot) for code G compressors and 1460 V DC (hi-pot) for code J compressors for one second between this short-circuit and the chassis, and leakage current must be less than 5 mA. When running dielectric strength tests of the entire installation, frequency converter and compressor electrical motor compressor test can be conducted together. When conducting a dielectric strength test, make sure the system is not under vacuum: this may cause electrical motor compressor failure.

- Please note, it is not recommended that a dielectric strength test be carried out too often as it may damage the motor. Nevertheless, if such a test is necessary, it must be performed at a lower voltage.
- Insulation resistance is measured with a 500 V DC megohm tester and must be higher than 1 megohm.
 - The presence of refrigerant around the motor windings will result in lower resistance values to ground and higher leakage current readings. Such readings do not indicate a faulty compressor. To prevent this, the system can be first operated briefly to distribute refrigerant.

INTEGRATION INTO SYSTEM



Do not use a megohm meter nor apply power to the compressor while it is under vacuum as this may cause internal damage.

ORDERING INFORMATION

Commissioning

Preliminary check



Check electrical power supply:

- Phase order: Reverse rotation is obvious if the compressor do not build up pressure and sound level is abnormal high. VLZ compressor will only operate properly in one direction. If electrical connections are done correctly between the drive and the compressor terminals (compressor

terminals T1,T2,T3 and drive terminals U, V & W matching), the drive will provide correct phase supply to the compressor, and reverse rotation will be not possible:For more details refer to "Motor protection".

- Voltage and voltage unbalance within tolerance: For more details refer to section "Motor voltage".

Initial start-up

- Crankcase heaters must be energized at least 6 hours in advance to remove refrigerant.
- Do not provide any power to the drive unless suction and discharge service valves on compressor are open, if installed.
- Energize the drive. The compressor must start, according to defined ramp-up settings. If the compressor does not start, check wiring conformity.
- Check the frequency converter control panel: If any alarm is displayed check the wiring and in

particular the polarity of the control cables.If an alarm is shown, refer to the frequency converter application manual. Verify in particular the combination of compressor, frequency converter and refrigerant.

- Check current draw and voltage levels on the mains. The values for the compressor electrical motor can be directly displayed on the frequency converter control panel.

System monitoring

The system must be monitored after initial startup for a minimum of 60 minutes to ensure proper operating characteristics such as:

- Proper metering device operation and desired superheat readings
- Suction and discharge pressure are within acceptable levels
- Correct oil level in compressor sump indicating proper oil return
- Low foaming in sight glass and compressor sump temperature 10K above saturation temperature to show that there is no refrigerant migration taking place
- Acceptable cycling rate of compressors, including duration of run times.

A short cycling protection is provided in the CDS frequency converter. It is factory preset "enabled" with the following parameters in:

- 28.01 - interval between 2 starts: 300 secondes
- 28.02 - minimum run time: 12 seconds.

This minimum run time is set to guaranty long enough running time at start up in order to create enough refrigerant flow velocity in the system to recover the oil to the compressor sump.

- Current draw of compressor within acceptable values (RLA ratings)
- No abnormal vibrations and noise.

Oil level checking and top-up

In installations with good oil return and line runs up to 15 m, no additional oil is required. If installation lines exceed 15 m, additional oil may be needed. 1 or 2% of the total system refrigerant charge (in kg) can be used to roughly define the required oil top-up quantity (in liters) but in any case the oil charge has to be adjusted based on the oil level in the compressor sight glass.

When the compressor is running under stabilized conditions, the oil level must be visible in the sight glass.

The presence of foam filling in the sight glass indicates large concentration of refrigerant in the oil and / or presence of liquid returning to the compressor.

The oil level can also be checked a few minutes after the compressor stops, the level must be between 1/4 and 3/4 of sight glass.

When the compressor is off, the level in the sight glass can be influenced by the presence of refrigerant in the oil.

Top-up the oil while the compressor is idle. Use the schrader connector or any other accessible connector on the compressor suction line and a suitable pump. See news bulletin "Lubricants filling in instructions for Danfoss Commercial Compressors" T1 2-025-0402.

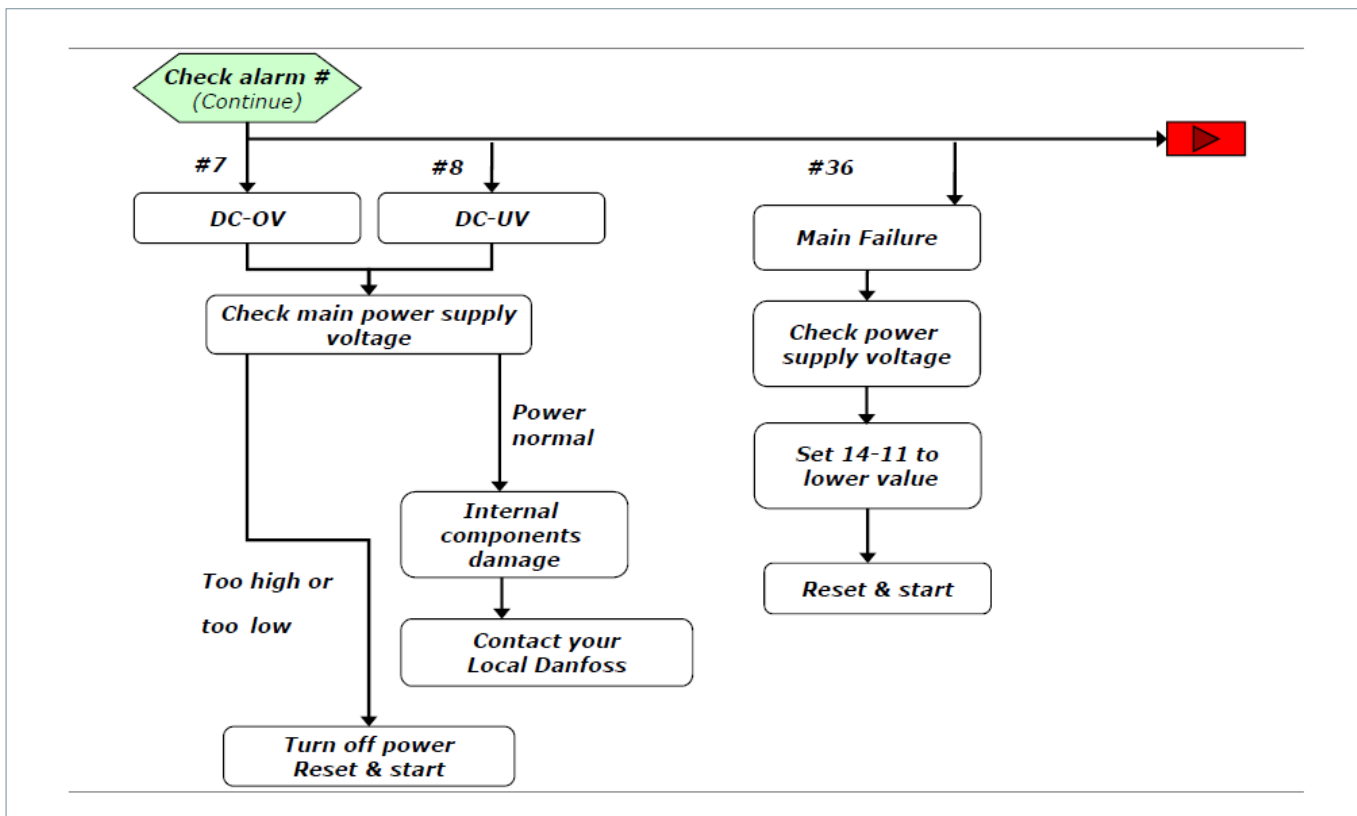
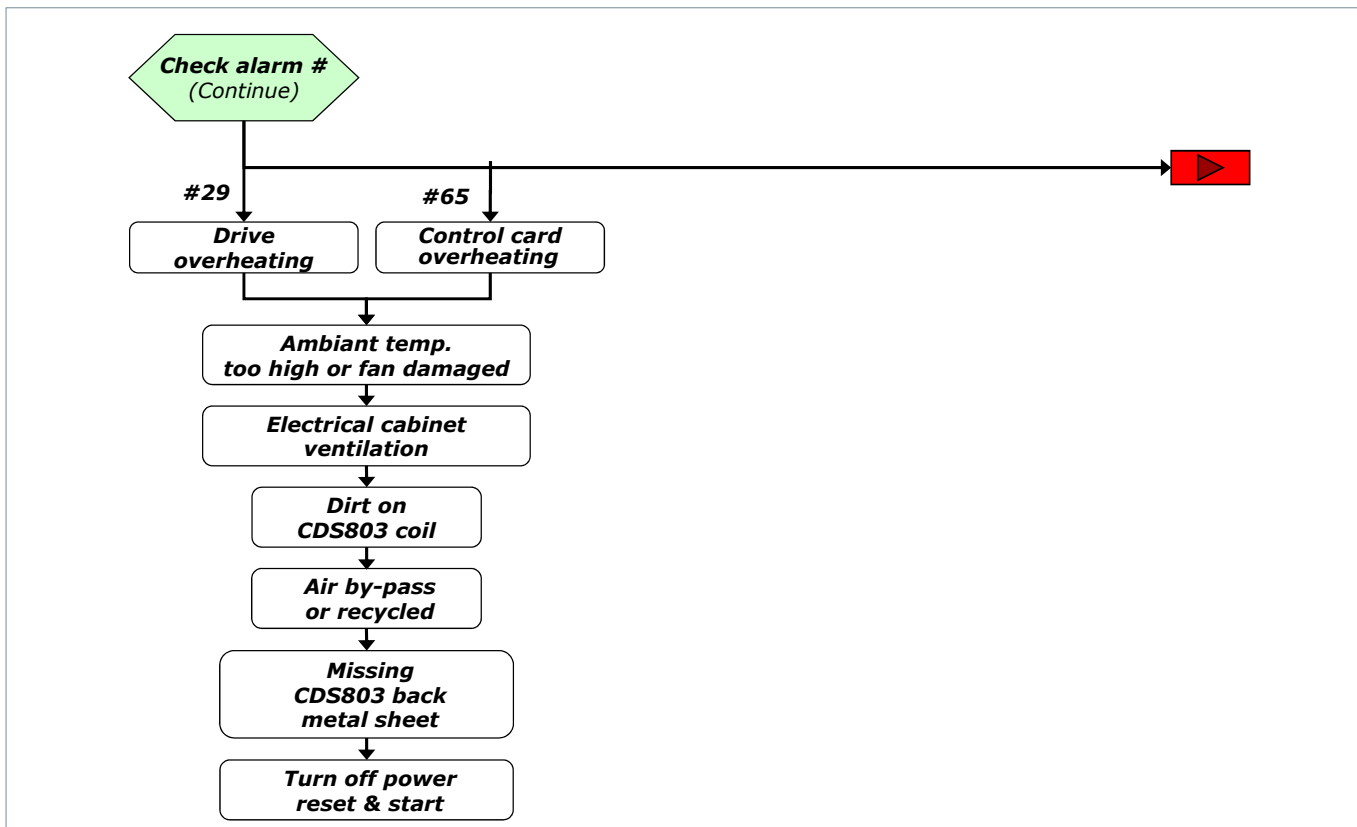

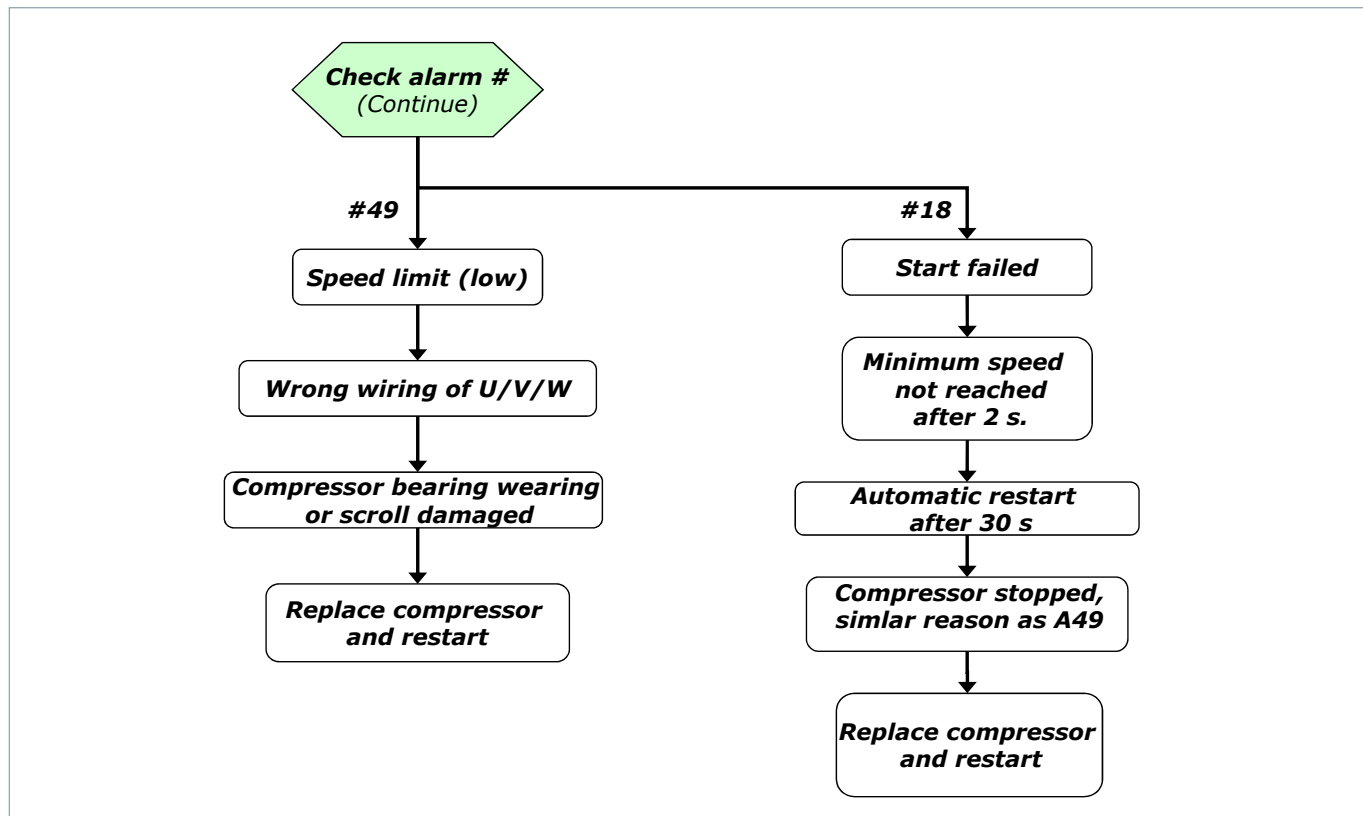

GENERAL INFORMATION
PRODUCT INFORMATION
SYSTEM DESIGN
INTEGRATION INTO SYSTEM
ORDERING INFORMATION

Dismantal and disposal



Danfoss recommends that compressors and compressor oil should be recycled by a suitable company at its site.

GENERAL INFORMATION

PRODUCT INFORMATION

SYSTEM DESIGN

INTEGRATION INTO SYSTEM

ORDERING INFORMATION

Packaging

Single pack

Compressor single pack



Compressor model	Height (mm)	Width (mm)	Depth (mm)	Weight (kg)
VLZ028-035-044	464	292	286	30

Compressor Industrial pack

Compressors are not packed individually but are shipped all together on one pallet. They can be ordered in quantities of full pallets only, multiples of 12 compressors, according to below table.

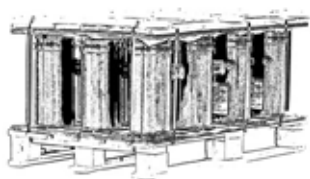

Compressor model	Nbr*	Length (mm)	Width (mm)	Height (mm)	Gross Weight (kg)	Static stacking pallets
VLZ028	12	1170	815	625	430	3
VLZ035	12	1170	815	625	450	3
VLZ044	12	1170	815	625	450	3

Frequency converter single pack

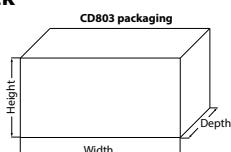

Drive supply voltage	Compressor	Drive enclosure	IP20			
			Height (mm)	Width (mm)	Depth (mm)	Weight (kg)
T2: Code J	VLZ028/035/044	H4	380	250	375	7.9
T4: Code G	VLZ028/035/044	H3	255	100	206	4.5

GENERAL INFORMATION

PRODUCT INFORMATION

SYSTEM DESIGN

INTEGRATION INTO SYSTEM

ORDERING INFORMATION

Ordering codes

Compressor code numbers

Danfoss scroll compressors VLZ can be ordered in either industrial packs or in single packs. Drive can be ordered in single packs. Please use the code numbers from below tables for ordering.

Single pack



Compressor model	Equipment version	G		J	
		Compressor Name	Code no	Compressor Name	Code no
VLZ028	Single	VLZ028TGNE9A/M	120G0162	VLZ028TJNE9A/M	120G0171
VLZ035	Single	VLZ035TGNE9A/M	120G0159	VLZ035TJNE9A/M	120G0168
VLZ044	Single	VLZ044TGNE9A/M	120G0156	VLZ044TJNE9A/M	120G0165

Industrial pack

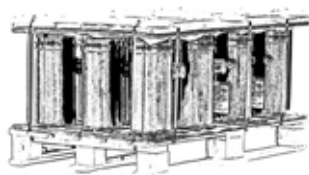

Compressor model	Equipment version	G 380-480V/3ph/50&60Hz		J 200-240V/3ph/50&60Hz	
		Compressor Name	Code no	Compressor Name	Code no
VLZ028	Single	VLZ028TGNE9A/I	120G0164	VLZ028TJNE9A/I	120G0173
VLZ035	Single	VLZ035TGNE9A/I	120G0161	VLZ035TJNE9A/I	120G0170
VLZ044	Single	VLZ044TGNE9A/I	120G0158	VLZ044TJNE9A/I	120G0167

VLZ converter order information

CDS803 drive			
Voltage	Compressor	Description	Code NO
T2 200-240V/3ph/50&60Hz	VLZ028-035-044	CDS803P7K5T2E20H4	134N4261
T4 380-480V/3ph/50&60Hz	VLZ028-035-044	CDS803P7K5T4E20H4	134N4263

LCP: use interface 120Z0581(accessory)

Accessories

Solder sleeve adapter set



Code n°	Description	Application	Packaging	Pack size
120Z0126	Solder sleeve adapter set (1"1/4 Rotolock, 3/4" ODF), (1" Rotolock, 1/2" ODF)	VLZ028-035-044	Multipack	6

Rotolock nuts and sleeves kit



Code n°	Description	Application	Packaging	Pack size
120Z5074	Rotolock nuts 1"1/4 and 1" with sleeves and gaskets	VLZ028-035-044	Multipack	6

Rotolock adapter



Code n°	Description	Application	Packaging	Pack size
120Z0365	Adaptor 1"~1/2"	VLZ028-035-044 discharge	Multipack	10
120Z0366	Adaptor (1-1/4" ~ 3/4")	VLZ028-035-044 suction	Multipack	10

Mounting kits



Code No	Description	Application	Packaging	Pack Size
120Z0622	Mounting kit for 1 scroll compressors including 4 grommets, 4 sleeves, 4 bolts, 4 washers, 2 grounding screws	VLZ028-035-044	Single pack	1

Crankcase heater



Code n°	Description	Application	Packaging	Pack size
120Z5040	Belt type crankcase heater,65W,230V,CE mark,UL(wire length: 1270mm)	VLZ028-044	Multipack	4
120Z5041	Belt type crankcase heater,55/70W,400/460V,CE mark,UL(wire length: 1270mm)		Multipack	4

Discharge thermostat kit



Code n°	Description	Application	Packaging	Pack size
7750009	Discharge thermostat kit	VLZ028-035-044	Multipack	10
7973008	Discharge thermostat kit	VLZ028-035-044	Industry pack	50

Accessories

Lubricant



Code n°	Description	Application	Packaging	Pack size
120Z0648	POE lubricant, 215PZ(RL46HB),1 litre can	VLZ028-035-044	Multipack	12

Acoustic hoods



Code No	Description	Application	Packaging	Pack Size
120Z5083	Acoustic hood for scroll compressor	VLZ028-035-044	Single pack	1

Terminal box



Code No	Description	Application	Packaging	Pack Size
120Z5015	Terminal box cover	VLZ028-035-044	Multipack	10

Spare parts frequency converter

LCP's

Type	Code n°	Description	Application	Packaging	Pack size
	120Z0581	LCP	Frequency converter 803 / VLZ028-035-044 code G & code J	Single pack	1
	120Z0617	LCP kit for remote mounting contains rubber sealing, 3m cable, bracket and screws	Frequency converter CDS803 / VLZ028-035-044 code G & code J	Single pack	1

Decoupling Plate

Frame	Compressor		Decoupling plate	Packaging	Pack size
	200-240V	380-480V			
H3	-	VLZ028/035/044	120Z0582	Single pack	1
H4	VLZ028/035/044	-	120Z0583	Single pack	1

Note: use the decoupling plate for EMC correct installation

Danfoss Commercial Compressors

is a worldwide manufacturer of compressors and condensing units for refrigeration and HVAC applications. With a wide range of high quality and innovative products we help your company to find the best possible energy efficient solution that respects the environment and reduces total life cycle costs.

We have 40 years of experience within the development of hermetic compressors which has brought us amongst the global leaders in our business, and positioned us as distinct variable speed technology specialists. Today we operate from engineering and manufacturing facilities spanning across three continents.



Danfoss Scrolls



Danfoss Inverter Scrolls



Danfoss Turbocor Compressors



Danfoss Light Commercial Refrigeration Compressors



Danfoss Maneurop Reciprocating Compressors



Danfoss Optyma Condensing Units

Our products can be found in a variety of applications such as rooftops, chillers, residential air conditioners, heatpumps, coldrooms, supermarkets, milk tank cooling and industrial cooling processes.

<http://cc.danfoss.com>

Danfoss Commercial Compressors, BP 331, 01603 Trévoux Cedex, France | +334 74 00 28 29



Danfoss can accept no responsibility for possible errors in catalogues, brochures and other printed material. Danfoss reserves the right to alter its products without notice. This also applies to products already on order provided that such alterations can be made without subsequential changes being necessary in specifications already agreed. All trademarks in this material are property of the respective companies. Danfoss and the Danfoss logotype are trademarks of Danfoss A/S. All rights reserved.