

ENGINEERING  
TOMORROW

*Danfoss*

Ball valves, butterfly valves, non-return valves and strainers

# Shut off the pressure loss Open up for energy savings

For heating, district heating and cooling systems

Up to

**30%**

energy savings and  
short payback time  
due to low pressure  
drop engineering.



## ЮГОВ - Проект

інженерно-виробниче підприємство

Офіційний дистриб'ютор  
Danfoss в Україні



ugov.ua

heating.danfoss.com

# What is shut-off system control?

**In every district heating utility, combined heat and power plant, distribution network and substation, there is a need for on/off control of the building system connection.**

With on/off regulation (opening and closing) shut-off valves create sectioning of the system that enables service, maintenance and repairs to be carried out in sections, without shutting down and emptying the whole system.

Using special types of ball valves (hot tap and branching), the network can be expanded while the system is fully operational.

From a heat generation plant to the smallest subscriber Danfoss gives you a comprehensive range of ball valves, butterfly valves as well as non-return valves and strainers to ensure system sectioning and maintenance for any application.

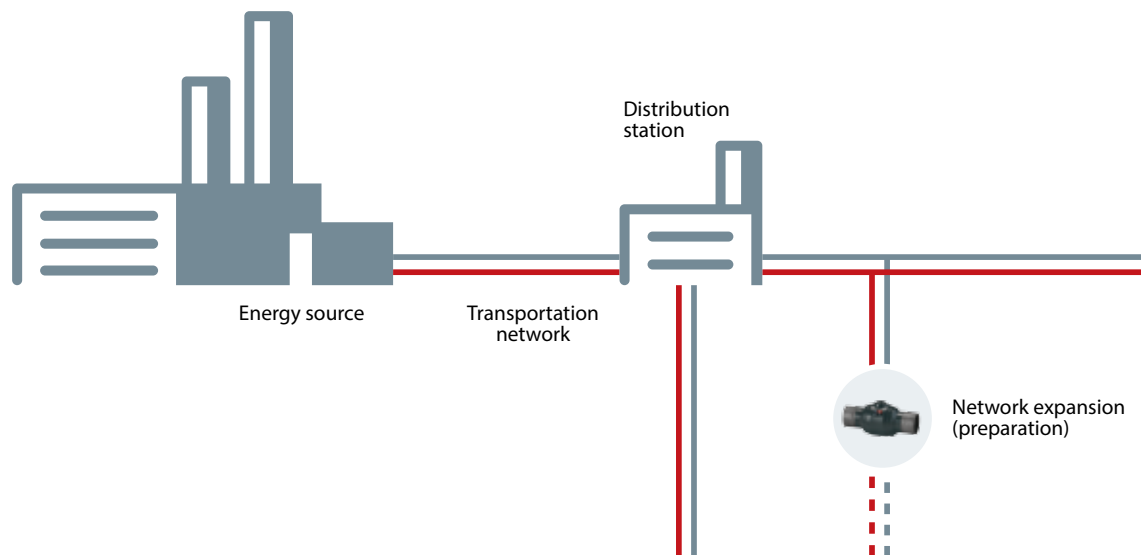

## Energy source and transportation network

The energy source and transportation network place the highest demands on equipment. This is because of the high demands of safety and reliability as well as the large volumes and pressures involved. Danfoss offers a full range of shut-off valves (JIP™ ball valves, SBFV butterfly valves) and FVF strainers suitable for high temperatures and available in large dimensions.

## Distribution network

The distribution network is the part of the primary network between the transportation network and consumption / subscriber stations. Operating conditions are not as tough as in the transportation network but demands placed on Danfoss products still are. This is because many smaller and mid-size systems are connected directly to the energy source. For distribution network Danfoss offers JIP™ ball valves and VFY butterfly valves.

## Expansion of the network

Both Transportation and Distribution network are often being expanded with new areas and users. Using Danfoss JIP™ branching ball valves network can be prepared in the initial phase to allow for future expansion. With Danfoss JIP™ hot tap ball valves new connections to the network can be added while the system is fully operational. This saves time and eliminates interruptions for the users.



JIP™

SBFV

FVF



JIP™

SBFV

FVF



JIP™ Branching

JIP™ Hot Tap

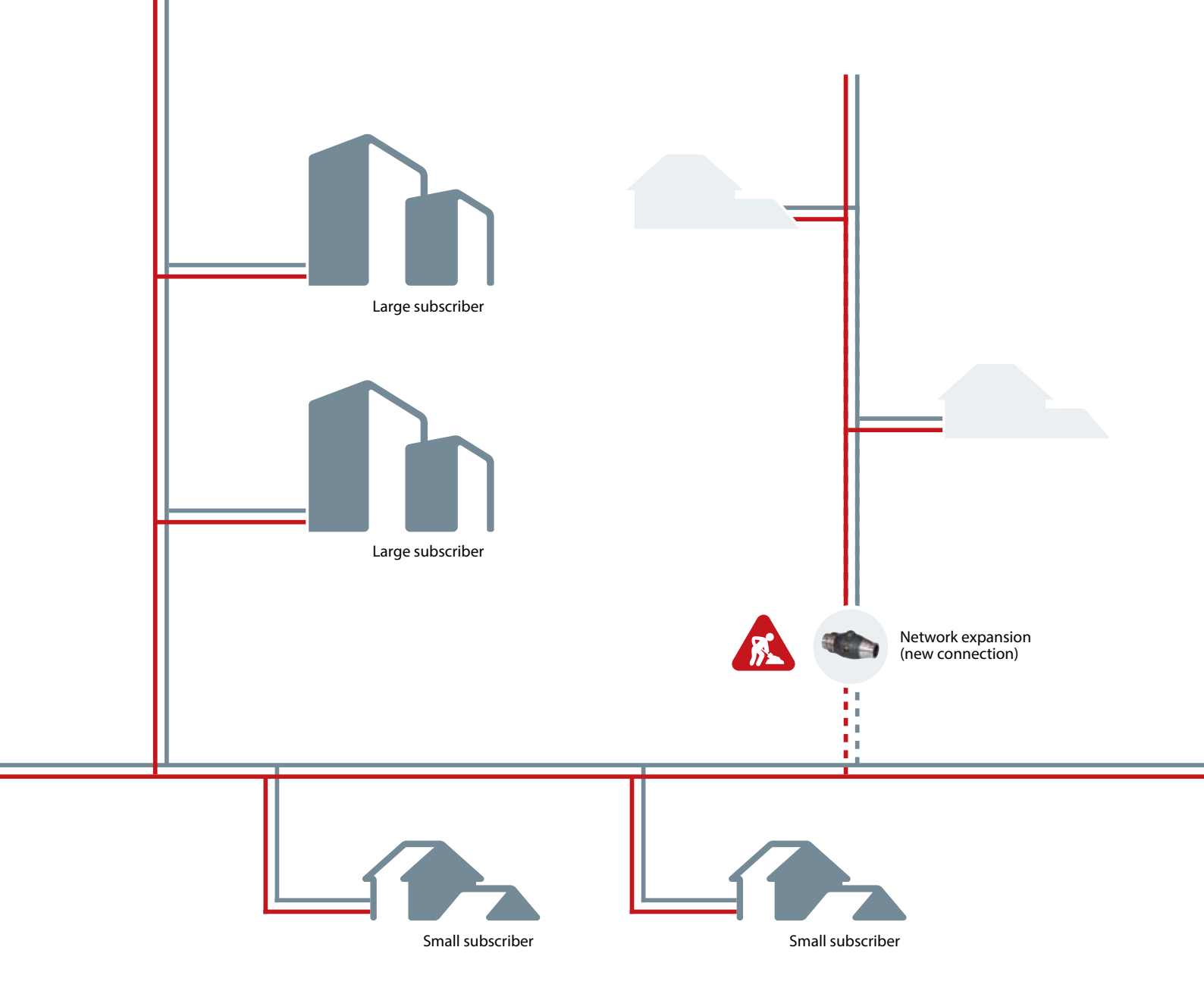

### Large subscriber substation

Large subscriber substations (commercial and multi-family residential buildings) are either directly or indirectly connected to the distribution network where ball valves (JIP™), butterfly valves (VFY), check valves (NVD) or strainers (FVF) can be used.

### Small subscriber

Small subscribers (single family houses) can be connected to the system using small sized twin ball valves (flow/return) dedicated for single or double preinsulated pipe connection. In addition to twin ball valves Danfoss offers also small sized single ball valves in different connections as well as small butterfly valves.



JIP™

VFY

FVF



VFY

JIP™ (single or twin)

# What defines an **optimum** ball valve solution?

## **Long lifetime**

An optimum ball valve is expected to have the same lifetime as the pipeline itself which is from 25 to 35 years, depending on the conditions.

## **Energy saving**

Ball valves are not big contributors to total pressure drop in the system, but since each application contains several shut-off valves in different locations the effect is multiplied. An optimum ball valve has low pressure drop and adds minimum resistance to the system.

## **Reliable sealing**

Optimum ball valves have sealing that is reliable and maintenance free during the lifetime.

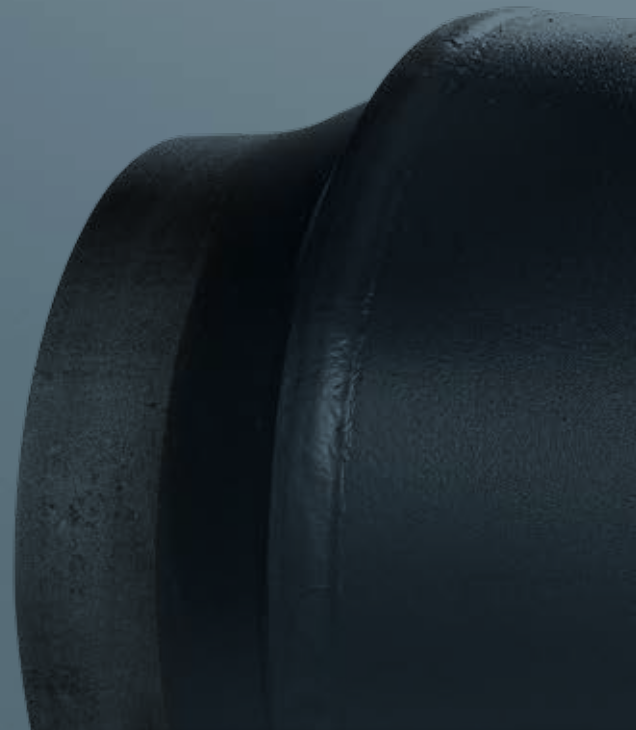



## What are the **key challenges** to overcome?

### **Achieving long lifetime**

Ball valves can, if used in proper conditions (treated water, no sediments, etc.), last 25 to 30 years. But polymer sealing materials (f.e. EPDM) that are often used for stem sealing of valves, age over the years and lose the initial performance which can lead to leakage.

### **Enabling energy savings**

Saving energy in a ball valve requires good knowledge in fluid dynamics in order to minimize the pressure loss.

### **The solution is... Danfoss JIP™**

# Danfoss JIP™

## The advanced ball valve with **optimum flow design**

Ball valves are expected to be maintenance free. They create sections in the system and are used during maintenance on other products. Larger sections of the system need to be closed down for maintenance on a ball valve.

Danfoss JIP™ steel ball valves with their features, present the leading and unique solution on the market of ball valves.

## What makes JIP™ **special?**

The unique flow design is represented by guiding pipes and pipe insert in the ball which ensures smooth flow through the ball eliminating cavitation and achieving a lower pressure drop.

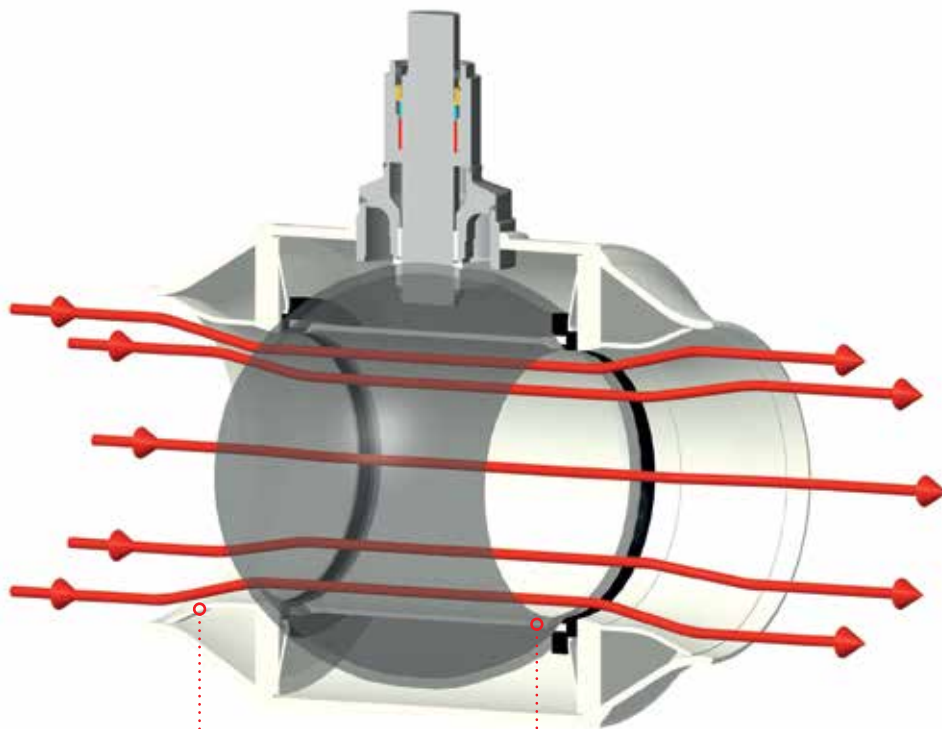

**Guiding pipes**  
Danfoss ball valves have cylindrical inlets and outlets that ensure smooth transition of the flow in and out of the ball valve.

**Ball with pipe insert**  
Ball design with pipe insert ensures smooth flow through the ball and eliminates cavitation.

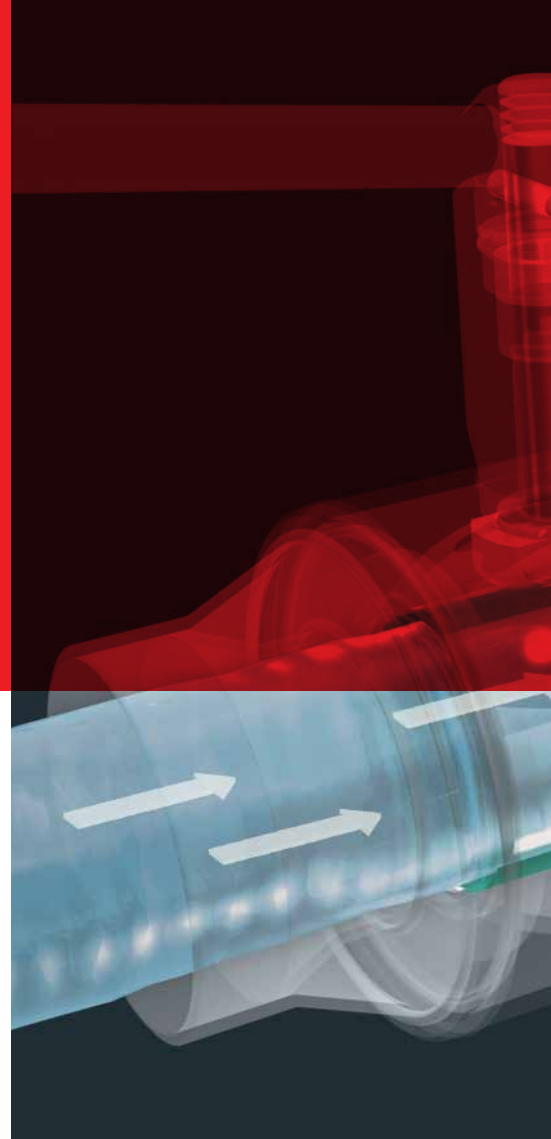

*Conventional ball valve creating disrupted flow*

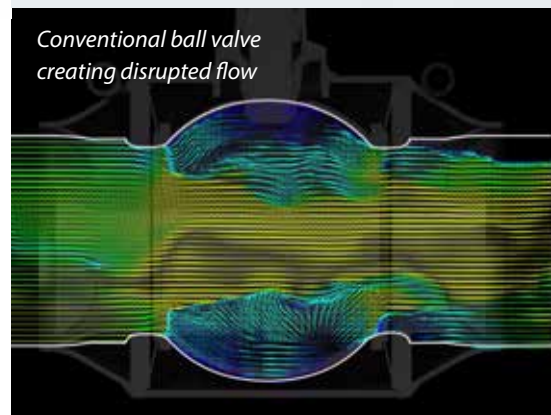

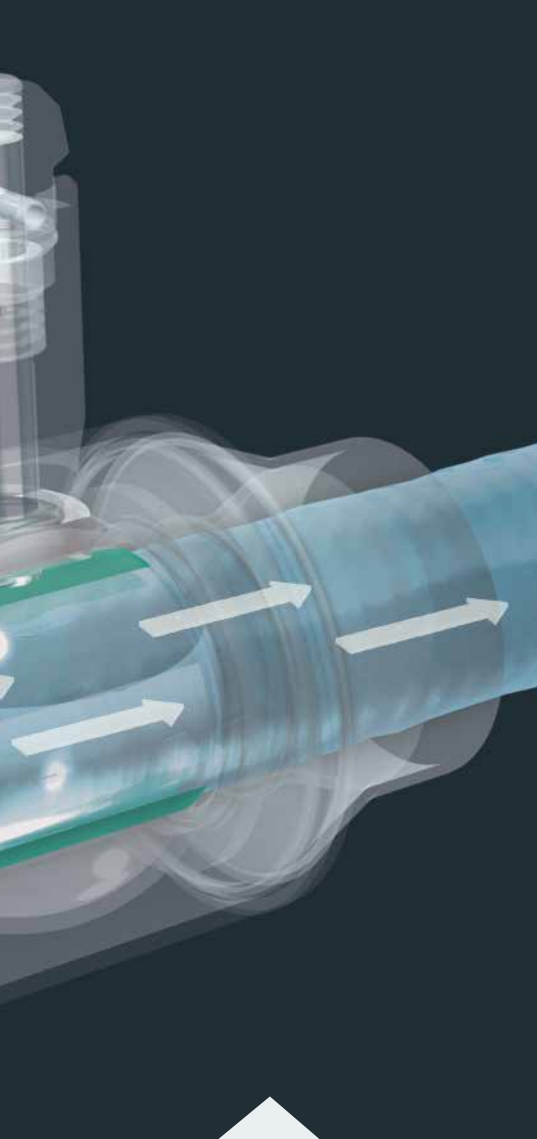

# The unique flow design enables a chain of events **leading to benefits**

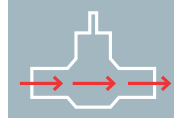

## **Optimum flow design**

Optimum flow design reduces pressure drop through the ball valve

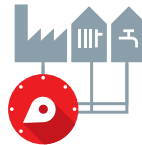

## **Low pressure drop**

Lower pressure drop equals higher kv value of the valve

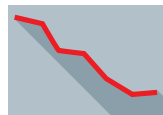

## **Low pump power consumption**

With reduced pressure drop through ball valves in the system, pumping power can be decreased which leads to lower operating costs



## Outcome 1: **Lower operating costs**

## Outcome 2: **Lower CO<sub>2</sub> emissions**

## Outcome 3: **Energy savings**

With low pressure drop due to the unique flow design we achieve lower pump consumption. Lower pump consumption contributes to lower operating costs and leads to energy saving. This means, that when using Danfoss JIP™ up to 30% less energy is needed to pump working media through a ball valve.

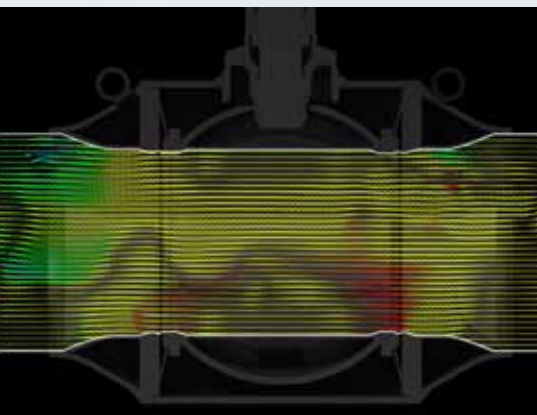

# Unique body design developed by Danfoss

Ensuring long lifetime and reliable tightness of the ball valve.

## Packing box construction

In order to secure complete tightness, we have developed a stem construction called a packing box. The packing box consists of stem sealing and an adjustable packing screw that prevents any external leakage.

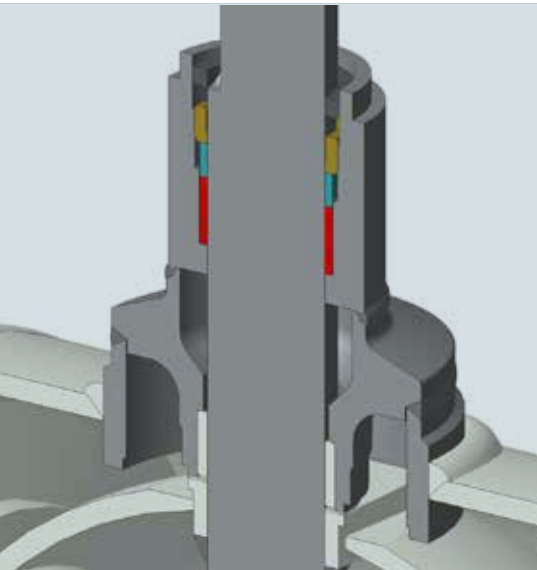
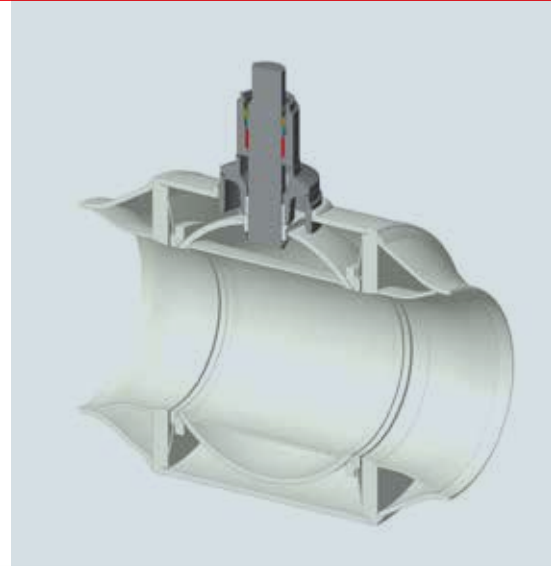

## Carbon reinforced sealing

Stem sealing is ensured with a carbon reinforced Teflon seal (PTFE+C) that will not deteriorate over the years even at high temperatures and temperature variations as opposed to polymer based O-rings.

## Adjustable packing screw

During the lifetime there is no need to change the stem seal. It can simply be re-tightened using the adjustable packing screw.

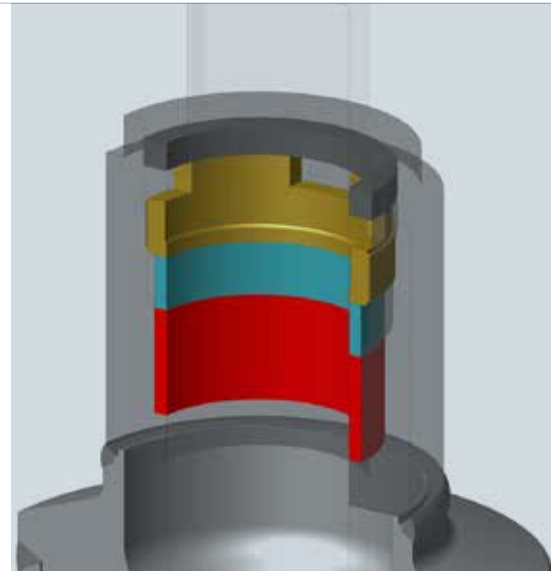

# Fully welded **body design**

This unique design is represented by a sophisticated break loose system, spring construction system and fully welded body.

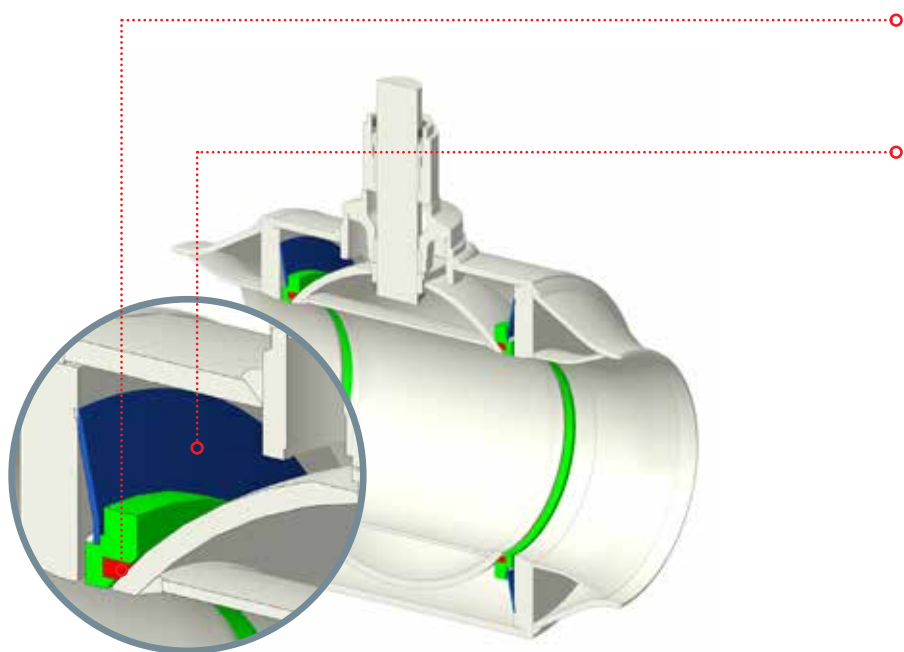

## **Carbon reinforced PTFE Rings**

Ensure complete tightness.

## **Sophisticated spring construction**

Ensures that the seals always will be pressed against the ball with a controlled operating force, independent of the axial forces.

## The advanced body design **benefit summary**

### **Extended lifetime of the product with no maintenance**

- Danfoss has developed a unique body design for ball valves
- This unique design consists of sophisticated packing box and spring construction
- Materials used for stem sealing (PTFE+C) does not age and extend the lifetime of the product
- With extended product lifetime we can achieve lower operating costs

### **Energy savings**

- Danfoss has developed a unique body design for ball valves
- These unique design features include optimized inlets and outlets (guiding pipes) and ball (pipe insert).
- Optimized flow design minimizes the pressure loss over the ball valve which reduces operating costs and saves on energy and CO<sub>2</sub> emissions



# Danfoss JIP™ Ball Valves for building installations

## Danfoss JIP™ reduce bore valves



OPERATION	L - Handle			Worm Gear / Actuator		L - Handle			Worm Gear / Actuator	
TYPE	Flange (FF)					Welding (WW)				
DN	15-50	65-200		65-500		15-50	65-200	65-600		
PN	40	16	25	16	25	40	25	25		



OPERATION	L - Handle		T - Handle	L - Handle		T - Handle	L - Handle		
TYPE	Flange / Welding (FW)			Internal thread (II)			Internal thread / Welding (IW)		
DN	15-50	65-200		15-25	15-50		15-25	15-50	
PN	40	16	25	40	40		40	40	

## Danfoss JIP™ full bore valves



OPERATION	L - Handle			Worm Gear / Actuator		L - Handle		Worm Gear / Actuator		L - Handle		
TYPE	Full Bore Flange (FF)					Full Bore Welding (WW)					Flange / Welding (FW)	
DN	15-50	65-150		150-400		15-50	65-150	50-400		15-50	65-150	
PN	40	16	25	16	25	40	25	25	40	16	25	

## Danfoss JIP™ draining valves



OPERATION	Hexagon		L - Handle		
TYPE	Welding / External thread + closing cap (WE)		Welding / External thread + closing cap (WE)		
DN	15-50		15-25		
PN	40		40		

# Danfoss JIP™ Ball Valves for building installations

## Danfoss JIP™ twin valves



OPERATION	T - Handle	L - handle	T - Handle	L - Handle	T - Handle	L - Handle	Insulation for twin single pipe  
TYPE	<b>Welded (WW)</b>		<b>Internal thread (II)</b>		<b>Internal thread / Welding (IW)</b>		
DN	15-25	32	15-25	32	15-25	32	
PN	40	40	40	40	40	40	



OPERATION	45° T - Handle		Insulation for twin double pipe  	
TYPE	<b>Internal thread (II)</b>			<b>Internal thread / Welding (IW)</b>
DN	15-25			15-25
PN	40			40

## Danfoss JIP™ copper valves



OPERATION	L - Handle	L - Handle
<b>TYPE</b>	<b>Copper (CC)</b>	<b>Internal thread / Copper (IC)</b>
DN	15-25	15-25
PN	16	16

## Danfoss JIP™ balancing ball valves

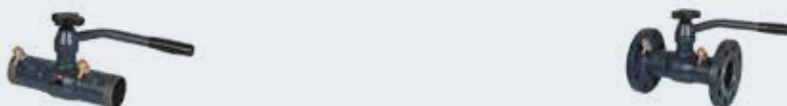

OPERATION	Handle and preset wheel	Handle and preset wheel
<b>TYPE</b>	<b>BaBV WW</b>	<b>BaBV FF</b>
DN	50-125	50-125
PN	25	25

# Danfoss JIP™ Ball Valves for extension of pre-insulated systems

## Danfoss JIP™ hot tap valves

The hot tap system enables an easy, safe, environmental friendly and economical connection of a new customer - without having to cut off the heating supply to other district heating customers. This ensures better service towards existing customers of the district heating net.



OPERATION	Allen Key	
<b>TYPE</b>	<b>Hot Tap (WW)</b>	
DN	20-50	65-100
PN	40	25



Toolbox DN65 - 100



Toolbox DN20 - 50



# Danfoss JIP™ branching valves

Branching ball valves are the solution for preparing the network for future extension. The valves are welded in place and the connection is added in the future when needed. When the extension is done, valves can be secured in the open position and easily insulated.



OPERATION	Allen Key / Hex		Allen Key / Hex		Allen Key / Hex
TYPE	Branching reduced bore (WW)		Branching Full bore (WW)		Branching reduced bore (CC)
DN	20-50	65-200	20-50	65-100	20-80
PN	40	25	40	25	25



# High performance butterfly valves

## Tight and reliable solution

### Special design for district heating and cooling applications

Danfoss SBFV are high performance steel butterfly valves that together with Danfoss JIP™ ball valves complete the family of shut off valves designed especially for district heating and district cooling systems.

Danfoss SBFV are triple offset butterfly valves with unique lamellar seat design that ensures reliable operation and tightness in both directions even at high and low temperatures. They are primarily designed as shut off valves, but can also be used for simple control purposes.

The packing box has been designed on the same principle as the JIP™ ball valves. Carbon reinforced PTFE sealing is used as it does not deteriorate over the years and can be tightened while in the pipeline thus ensuring external tightness for the lifetime of the valve.



OPERATION	Worm Gear or Electric actuator		
<b>TYPE</b>	<b>Flange (FF)</b>		<b>Welding (WW)</b>
DN	200-1400		200-1400
PN	16	25	25

# Danfoss VFY

Danfoss VFY are concentric butterfly valves with a replaceable EPDM liner design that ensures reliable operation and tightness in both directions. They have a one piece shaft with splines that ensure strong connection with the disc and anti blow-out protection for safe use.



OPERATION	Handle		Gearbox		Electric actuator
TYPE	Wafer	Lug	Wafer	Lug	Wafer
DN	25-300	32-300	50-600	50-600	50-600
PN	16		16		16



# Non return valves and strainers

Protect your components in the system

## Danfoss NVD

Danfoss NVD is a wide range of non-return valves available in different designs to meet different demands in relation to head loss, speed of operation, connection type and price.



TYPE	NVD 402	NVD 462	NVD 802	NVD 812	NVD 895	NVD 805
Connection	Flange		Between flange		Between flange	
DN	40-500	50-200	32-200	15-200	50-400	50-600

# Danfoss FVF

Strainers protect sensitive equipment like meters, pumps and control valves against danger caused by foreign particles in the working media.

Danfoss FVF are cast iron strainers with flanged connection available with a plug, magnetic insert or drain valve. Combination with drain valve allows quick and efficient cleaning.



Connection	Flange	
DN	15-300	
PN	16	25



Magnetic insert



Strainer with mounted draining valve

# Long lasting quality to the core

## Danfoss valves in fact

System reliability, building and occupant safety are crucial when it comes to district heating and cooling applications. This is why we pay special attention to design and material selection used in our products. Valve bodies are made of high quality bronze and cast iron/steel. Critical internal parts are made of well-proven stainless steel 1.4404 /1.4571 /1.4021. that in combination with a specially designed valve seat and cone ensures resistance to cavitation and corrosion. Danfoss products will ensure trouble free operation, low maintenance and operational costs.

### About Danfoss

For more than 75 years Danfoss has been supplying innovative heating solutions that cover everything from individual components to complete district heating systems. Danfoss engineers technologies that enable the world of tomorrow to do more with less. We employ 24,000 people and serve customers in more than 100 countries. Driven by our customers' needs, we build on years of experience to be at the forefront of innovation, continually supplying components, expertise and complete systems for climate and energy applications.

Today, our advanced, reliable and user-friendly technology helps to keep people comfortable and companies competitive across the world.

We play an active role in the main growth themes in a world that is rapidly changing: Infrastructure, food, energy and climate are the focus of our business. Cities for millions that touch the sky. A richer harvest to feed a growing world. Keeping food fresh and our children warm in a world that can make more out of less. This is how we are Engineering Tomorrow.

Read more online at  
[www.heating.danfoss.com](http://www.heating.danfoss.com)



**Danfoss A/S** · Heating Segment · 6430 Nordborg · Denmark  
Tel.: +45 74 88 22 22 · Email: [heating@danfoss.com](mailto:heating@danfoss.com) · [www.heating.danfoss.com](http://www.heating.danfoss.com)

Danfoss can accept no responsibility for possible errors in catalogues, brochures and other printed material. Danfoss reserves the right to alter its products without notice. This also applies to products already on order provided that such alterations can be made without subsequential changes being necessary in specifications already agreed. All trademarks in this material are property of the respective companies. Danfoss and the Danfoss logotype are trademarks of Danfoss A/S. All rights reserved.