

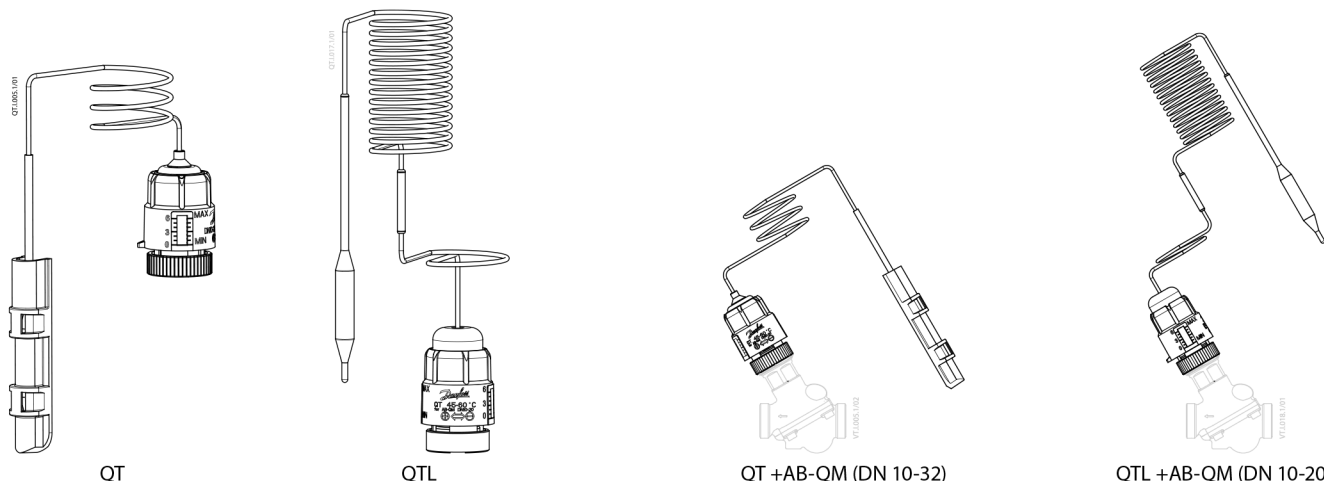

Operating Guide

Thermostatic actuator QT / QTL / 73693940

# Thermostatic actuator QT / QTL



<b>ENGLISH</b>	Thermostatic actuator QT / QTL	<a href="http://www.danfoss.com">www.danfoss.com</a>	Page 3
<b>DEUTSCH</b>	Thermostatischer Stellantrieb QT / QTL	<a href="http://www.waerme.danfoss.de">www.waerme.danfoss.de</a>	Seite 4
<b>MAGYAR</b>	QT / QTL Termostatikuss állítómű	<a href="http://www.danfoss.com">www.danfoss.com</a>	5. oldal
<b>POLSKI</b>	Element termostatyczny QT / QTL	<a href="http://www.heating.danfoss.pl">www.heating.danfoss.pl</a>	Strona 6
<b>РУССКИЙ</b>	Термостатический элемент QT / QTL	<a href="http://www.danfoss.ru">www.danfoss.ru</a>	Страница 7
<b>中文</b>	恒温驱动器 QT / QTL	<a href="http://www.danfoss.com.cn">www.danfoss.com.cn</a>	8页
<b>ČESKY</b>	Termostatický pohon QT / QTL	<a href="http://www.cz.danfoss.com">www.cz.danfoss.com</a>	Strana 9
<b>EESTI</b>	Termostaat QT / QTL	<a href="http://www.kyte.danfoss.ee">www.kyte.danfoss.ee</a>	Lehekülj 10
<b>LIETUVIŲ K.</b>	Termostatinė pavara QT / QTL	<a href="http://www.sildymas.danfoss.lt">www.sildymas.danfoss.lt</a>	Puslapis 11
<b>LATVISKI</b>	Termostatiskais aktuātors QT / QTL	<a href="http://www.danfoss.com">www.danfoss.com</a>	Lappuse 12

Thermostatic actuator QT / QTL

1

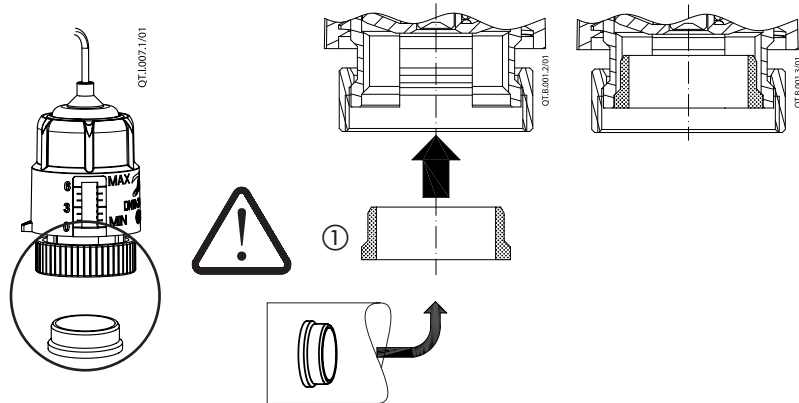

2

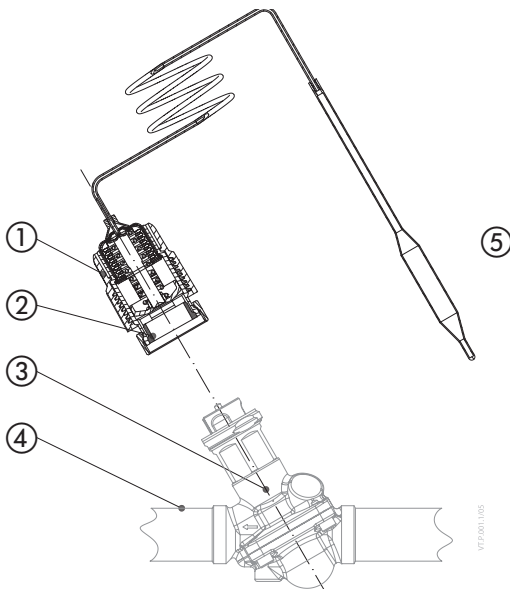

3

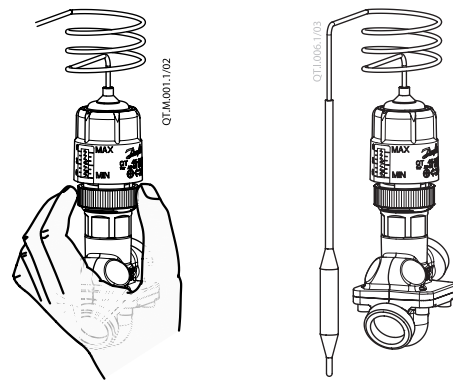

4

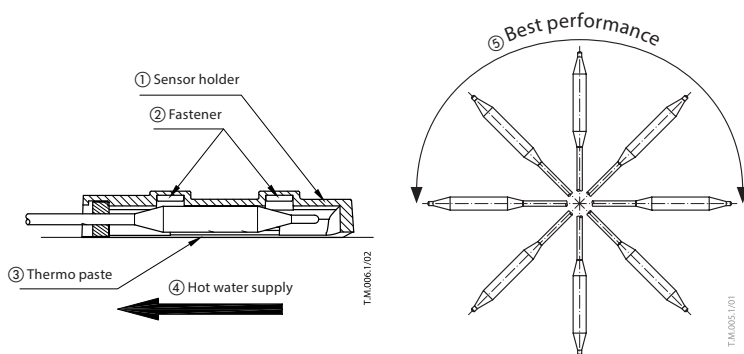

5

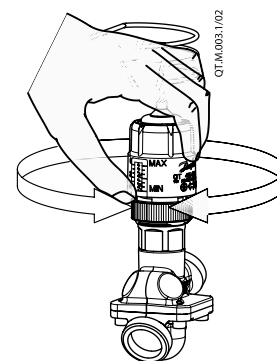

## Thermostatic actuator QT / QTL

### ENGLISH

#### Assembly ①

Insert adapter ① into thermostat neck

#### Design ②

Mount AB-QM valve ③ on hot-water pipe (see instruction for AB-QM)

- ① Setting knob
- ② Adapter
- ③ AB-QM valve
- ④ Hot-water pipe
- ⑤ Temperature sensor

Set desired setting on AB-QM (see instruction for AB-QM)

#### Mounting ③

QT/QTL should be mounted on the AB-QM by hand. Maximum allowed torque is 5 Nm.

#### Sensor installation ④

AB-QM is to be installed on the return pipe. In general the sensor must always be placed warmer than the thermostat head.

In case of one-pipe system the AB-QM needs to be installed after and as close as possible to the last radiator.

QT should be mounted on the AB-QM by hand. Maximum allowed torque is 5 Nm.

For proper heat transfer between a heating water pipe and the thermostat sensor, it is very important to apply thermo paste (included in the box) on the surfaces in contact.

It is recommended to insulate the sensor if the thermostat is installed in a very cold place (< 5 °C).

Sensor itself can be mounted in any direction. It can be mounted above or below sensor head.

#### Setting ⑤

QT/QTL temperature setting depends on AB-QM flow setting.

It is necessary to set the AB-QM to desired setting before the thermostat is mounted. It is recommended to set AB-QM between 30 and 70 % flow setting.

QT/QTL thermostat is set to the desired setting by hand. When minimum or maximum setting is required, QT/QTL setting knob is to be moved slightly in opposite direction to ensure optimal performance of the thermostat.

**Please note that the attached tables are indicative and will vary depending on the application. They are to be used as a guidance only. For exact temperature verification temperature needs to be measured at reference point and the sensor setting adjusted accordingly.**

#### AB-QM DN 10-20 (35-50 °C)

Temp. setting (°C)	QT Sensor setting (turns)						
	0	1	2	3	4	5	6
20 %	38.0	40.5	43.0	45.5	48.0	50.5	53.0
30 %	37.0	39.5	42.0	44.5	47.0	49.5	52.0
40 %	36.0	38.5	41.0	43.5	46.0	48.5	51.0
50 %	35.0	37.5	40.0	42.5	45.0	47.5	50.0
60 %	34.0	36.5	39.0	41.5	44.0	46.5	49.0
70 %	33.0	35.5	38.0	40.5	43.0	45.5	48.0
80 %	32.0	34.5	37.0	39.5	42.0	44.5	47.0
90 %	31.0	33.5	36.0	38.5	41.0	43.5	46.0
100 %	30.0	32.5	35.0	37.5	40.0	42.5	45.0

Factory setting of the thermostat is 4.

#### AB-QM DN 10-20 (45-60 °C)

Temp. setting (°C)	QT Sensor setting (turns)						
	0	1	2	3	4	5	6
20 %	48.0	50.5	53.0	55.5	58.0	60.5	63.0
30 %	47.0	49.5	52.0	54.5	57.0	59.5	62.0
40 %	46.0	48.5	51.0	53.5	56.0	58.5	61.0
50 %	45.0	47.5	50.0	52.5	55.0	57.5	60.0
60 %	44.0	46.5	49.0	51.5	54.0	56.5	59.0
70 %	43.0	45.5	48.0	50.5	53.0	55.5	58.0
80 %	42.0	44.5	47.0	49.5	52.0	54.5	57.0
90 %	41.0	43.5	46.0	48.5	51.0	53.5	56.0
100 %	40.0	42.5	45.0	47.5	50.0	52.5	55.0

Factory setting of the thermostat is 4.

#### AB-QM DN 10-20 (65-85 °C)

Temp. setting (°C)	QT Sensor setting (turns)						
	0	1	2	3	4	5	6
20 %	68.5	71.0	73.5	76.5	80.0	83.5	87.5
30 %	67.0	70.0	72.5	76.0	79.0	82.5	86.5
40 %	66.0	69.0	71.5	75.0	78.5	81.5	85.5
50 %	65.0	68.0	71.0	74.5	77.5	81.0	85.0
60 %	63.5	67.0	70.5	74.0	76.5	80.0	84.0
70 %	62.0	65.5	69.0	72.5	75.5	79.0	83.5
80 %	60.5	64.0	67.5	71.0	74.5	78.0	83.0
90 %	58.5	62.5	66.0	69.5	73.5	77.5	82.0
100 %	57.0	61.0	64.5	68.0	72.5	77.0	81.5

Factory setting of the thermostat is 4.

#### AB-QM DN 25-32 (35-50 °C)

Temp. setting (°C)	QT Sensor setting (turns)						
	0	1	2	3	4	5	6
20 %	39.5	42.0	44.5	47.0	49.5	52.0	54.5
30 %	38.0	40.5	43.0	45.5	48.0	50.5	53.0
40 %	36.5	39.0	41.5	44.0	46.5	49.0	51.5
50 %	35.0	37.5	40.0	42.5	45.0	47.5	50.0
60 %	33.5	36.0	38.5	41.0	43.5	46.0	48.5
70 %	32.0	34.5	37.0	39.5	42.0	44.5	47.0
80 %	30.5	33.0	35.5	38.0	40.5	43.0	45.5
90 %	29.0	31.5	34.0	36.5	39.0	41.5	44.0
100 %	27.5	30.0	32.5	35.0	37.5	40.0	42.5

Factory setting of the thermostat is 4.

#### AB-QM DN 25-32 (45-60 °C)

Temp. setting (°C)	QT Sensor setting (turns)						
	0	1	2	3	4	5	6
20 %	49.5	52.0	54.5	57.0	59.5	62.0	64.5
30 %	48.0	50.5	53.0	55.5	58.0	60.5	63.0
40 %	46.5	49.0	51.5	54.0	56.5	59.0	61.5
50 %	45.0	47.5	50.0	52.5	55.0	57.5	60.0
60 %	43.5	46.0	48.5	51.0	53.5	56.0	58.5
70 %	42.0	44.5	47.0	49.5	52.0	54.5	57.0
80 %	40.5	43.0	45.5	48.0	50.5	53.0	55.5
90 %	39.0	41.5	44.0	46.5	49.0	51.5	54.0
100 %	37.5	40.0	42.5	45.0	47.5	50.0	52.5

Factory setting of the thermostat is 4.

#### AB-QM DN 25-32 (65-85 °C)

Temp. setting (°C)	QT Sensor setting (turns)						
	0	1	2	3	4	5	6
20 %	72.5	75.0	77.5	80.0	84.0	88.0	92.5
30 %	70.0	73.0	75.5	78.0	82.0	86.0	90.5
40 %	67.5	70.5	73.3	76.0	80.0	83.5	87.0
50 %	65.0	68.0	72.0	74.0	77.5	80.5	85.0
60 %	62.5	65.8	69.2	72.5	76.5	79.0	84.0
70 %	60.0	64.5	68.5	71.5	75.5	78.0	83.0
80 %	58.0	63.0	67.0	70.0	74.0	77.0	81.5
90 %	56.5	61.0	65.0	69.0	72.5	76.5	80.5
100 %	55.0	59.0	63.0	67.5	71.5	75.5	79.5

Factory setting of the thermostat is 4.

# Thermostatic actuator QT / QTL

## DEUTSCH

### Installation ①

Den mitgelieferten Adapter ① in den Fühlerhals einlegen.

### Konstruktion ②

Das AB-QM Ventil ③ in der Heizungsleitung montieren (siehe Instruktion für AB-QM)

- ① Handrad mit Einstellskala
- ② Adapter
- ③ AB-QM Ventil
- ④ Heizungsleitung
- ⑤ Temperaturfühler

Den gewünschten Durchfluss an AB-QM einstellen (siehe Instruktion von AB-QM)

### Montage ③

QT/QTL ist ausschließlich von Hand zu montieren. Das maximal zulässige Drehmoment beträgt 5 Nm.

### Montage des Fühlers ④

Das AB-QM ist im Rücklauf zu installieren. Der Fühler muss im Allgemeinen immer an einem wärmeren Platz als der Temperaturregler platziert werden.

Bei einem Einrohrsystem muss das AB-QM so nah wie möglich nach dem letzten Heizkörper installiert werden.

QT ist ausschließlich von Hand zu montieren. Das maximal zulässige Drehmoment beträgt 5 Nm.

Für eine gute Wärmeübertragung von der Heizungsleitung und dem Temperaturfühler ist es erforderlich Wärmeleitpaste (im Lieferumfang enthalten) auf die Kontaktflächen aufzubringen.

Es wird empfohlen den Fühler mit der Rohrleitung zu isolieren.

Der Fühler kann in beliebiger Einbaulage montiert werden. Beste Regeleigenschaften werden bei waagrecht bis aufrechter Einbaulage erzielt.

- ① Fühlerhülse (Sensor holder)
- ② Befestigung (Fastener)
- ③ Wärmeleitpaste (Thermo paste)
- ④ Filiebrichtrung (Hotwater supply)
- ⑤ Beste Regeleigenschaften (Best performance)

### Einstellung des Temperaturreglers ⑤

Die Temperatureinstellung an QT/QTL ist von der VolumenstromEinstellung an AB-QM abhängig.

Es ist erforderlich, den gewünschten Durchfluss an AB-QM vor der Montage des Temperaturreglers einzustellen. Dabei werden Einstellungen zwischen 30 und 70 % am AB-QM empfohlen.

Die gewünschte Einstellung des Temperaturreglers QT/QTL wird durch Drehen des Handrades eingestellt. Dies geschieht von Hand auf den Einstellwert nach Tabelle. Wenn minimale oder maximale Einstellung erforderlich sind, ist das Handrad des QT/QTL bis zum Anschlag und dann ganz leicht in die entgegen gesetzte Richtung zu drehen. Damit sind die optimalen Regeleigenschaften des Temperaturreglers gewährleistet.

**Bitte beachten Sie, dass es sich bei den beigefügten Tabellen um Richtwerte handelt, die je nach Anwendung variieren. Sie sind lediglich zur Orientierungshilfe gedacht. Zur exakten Bestimmung muss die Temperatur am Referenzpunkt gemessen und die Fühler-Einstellung entsprechend angepasst werden.**

#### AB-QM DN 10-20 (35-50 °C)

Temp. einstellung (°C)	QT Handradeinstellung (Umdrehungen)						
	0	1	2	3	4	5	6
20 %	38.0	40.5	43.0	45.5	48.0	50.5	53.0
30 %	37.0	39.5	42.0	44.5	47.0	49.5	52.0
40 %	36.0	38.5	41.0	43.5	46.0	48.5	51.0
50 %	35.0	37.5	40.0	42.5	45.0	47.5	50.0
60 %	34.0	36.5	39.0	41.5	44.0	46.5	49.0
70 %	33.0	35.5	38.0	40.5	43.0	45.5	48.0
80 %	32.0	34.5	37.0	39.5	42.0	44.5	47.0
90 %	31.0	33.5	36.0	38.5	41.0	43.5	46.0
100 %	30.0	32.5	35.0	37.5	40.0	42.5	45.0

Die Werkseinstellung des Temperaturreglers beträgt 4.

#### AB-QM DN 10-20 (45-60 °C)

Temp. einstellung (°C)	QT Handradeinstellung (Umdrehungen)						
	0	1	2	3	4	5	6
20 %	48.0	50.5	53.0	55.5	58.0	60.5	63.0
30 %	47.0	49.5	52.0	54.5	57.0	59.5	62.0
40 %	46.0	48.5	51.0	53.5	56.0	58.5	61.0
50 %	45.0	47.5	50.0	52.5	55.0	57.5	60.0
60 %	44.0	46.5	49.0	51.5	54.0	56.5	59.0
70 %	43.0	45.5	48.0	50.5	53.0	55.5	58.0
80 %	42.0	44.5	47.0	49.5	52.0	54.5	57.0
90 %	41.0	43.5	46.0	48.5	51.0	53.5	56.0
100 %	40.0	42.5	45.0	47.5	50.0	52.5	55.0

Die Werkseinstellung des Temperaturreglers beträgt 4.

#### AB-QM DN 10-20 (65-85 °C)

Temp. einstellung (°C)	QT Handradeinstellung (Umdrehungen)						
	0	1	2	3	4	5	6
20 %	68.5	71.0	73.5	76.0	78.5	81.0	83.5
30 %	67.0	70.0	72.5	75.0	77.5	80.0	82.5
40 %	66.0	69.0	71.5	74.0	76.5	79.0	81.5
50 %	65.0	68.0	70.5	73.0	75.5	78.0	80.5
60 %	63.5	67.0	70.5	74.0	77.5	81.0	84.5
70 %	62.0	65.5	69.0	72.5	76.0	79.5	83.0
80 %	60.5	64.0	67.5	71.0	74.5	78.0	81.5
90 %	58.5	62.5	66.0	69.5	73.5	77.5	81.5
100 %	57.0	61.0	64.5	68.0	72.0	76.0	80.0

Die Werkseinstellung des Temperaturreglers beträgt 4.

#### AB-QM DN 25-32 (35-50 °C)

Temp. einstellung (°C)	QT Handradeinstellung (Umdrehungen)						
	0	1	2	3	4	5	6
20 %	39.5	42.0	44.5	47.0	49.5	52.0	54.5
30 %	38.0	40.5	43.0	45.5	48.0	50.5	53.0
40 %	36.5	39.0	41.5	44.0	46.5	49.0	51.5
50 %	35.0	37.5	40.0	42.5	45.0	47.5	50.0
60 %	33.5	36.0	38.5	41.0	43.5	46.0	48.5
70 %	32.0	34.5	37.0	39.5	42.0	44.5	47.0
80 %	30.5	33.0	35.5	38.0	40.5	43.0	45.5
90 %	29.0	31.5	34.0	36.5	39.0	41.5	44.0
100 %	27.5	30.0	32.5	35.0	37.5	40.0	42.5

Die Werkseinstellung des Temperaturreglers beträgt 4.

#### AB-QM DN 25-32 (45-60 °C)

Temp. einstellung (°C)	QT Handradeinstellung (Umdrehungen)						
	0	1	2	3	4	5	6
20 %	49.5	52.0	54.5	57.0	59.5	62.0	64.5
30 %	48.0	50.5	53.0	55.5	58.0	60.5	63.0
40 %	46.5	49.0	51.5	54.0	56.5	59.0	61.5
50 %	45.0	47.5	50.0	52.5	55.0	57.5	60.0
60 %	43.5	46.0	48.5	51.0	53.5	56.0	58.5
70 %	42.0	44.5	47.0	49.5	52.0	54.5	57.0
80 %	40.5	43.0	45.5	48.0	50.5	53.0	55.5
90 %	39.0	41.5	44.0	46.5	49.0	51.5	54.0
100 %	37.5	40.0	42.5	45.0	47.5	50.0	52.5

Die Werkseinstellung des Temperaturreglers beträgt 4.

#### AB-QM DN 25-32 (65-85 °C)

Temp. einstellung (°C)	QT Handradeinstellung (Umdrehungen)						
	0	1	2	3	4	5	6
20 %	72.5	75.0	77.5	80.0	82.5	85.0	87.5
30 %	70.0	73.0	75.5	78.0	80.5	83.0	85.5
40 %	67.5	70.5	73.0	76.0	78.5	81.0	83.5
50 %	65.0	68.0	71.0	74.0	77.0	80.0	83.0
60 %	62.5	65.8	69.2	72.5	75.8	79.2	82.5
70 %	60.0	64.5	68.5	71.5	75.5	79.0	82.5
80 %	58.0	63.0	67.0	70.0	74.0	77.0	81.0
90 %	56.5	61.0	65.0	69.0	72.5	76.5	80.5
100 %	55.0	59.0	63.0	67.5	71.5	75.5	79.5

Die Werkseinstellung des Temperaturreglers beträgt 4.

**MAGYAR**
**Adapter csatlakoztatása ①**

Helyezze az adaptert ① a termosztát nyakába

**Szelep beépítése ②**

Szerelje az AB-QM szelepet ③ a csővezetékbe (az AB-QM szelephez tartozó beépítési utasításnak megfelelően)

- ① Állító gomb
- ② Adapter
- ③ AB-QM szelep
- ④ Csővezeték
- ⑤ Hőmérséklet érzékelő

Állítsa be a szükséges térfogatáramot az AB-QM szelepen (az AB-QM szelephez tartozó beépítési utasításnak megfelelően)

**Állítómű csatlakoztatása ③**

Szerelje a termosztátot az AB-QM szelepre, a hollandi csavarzatot kéz zel húzza meg max. 5 Nm nyomatékkal.

**Az érzékelő elhelyezése ④**

Az AB-QM egységet a visszatérő ágba kell telepíteni. Az érzékelőt általában mindig melegebb helyen kell elhelyezni, mint a termosztátfejet.

Egycsöves rendszer esetén, az AB-QM egységet az utolsó fűtőtest után, ahhoz a lehető legközelebb kell telepíteni.

A QT érzékelőt kézzel meghúzva kell a szelepre felszerelni, maximum 5 Nm nyomatékkal megszorítani.

A cső és érzékelő közötti megfelelő hőátadás biztosítása érdekében fontos hővezető paszta alkalmazása (tartozék) az érintkező felületek között.

Javasolt az érzékelő hőszigetelése amennyiben az hideg térben kerül felszerelésre (<5 °C).

Az érzékelőt tetszőleges irányban fel lehet szerelni.

- ① Érzékelőtartó (Sensor holder)
- ② Rögzítő (Fastener)
- ③ Hőpaszta (Thermo paste)
- ④ Melegvíz betáplálás (Hotwater supply)
- ⑤ Beépítési helyzet (Best performance)

**Érzékelő beállítása ⑤**

A QT/QTL beállítása függ az AB-QM szelep előbeállításától.

Az AB-QM szelep előbeállítását az érzékelő felszerelése előtt kell elvégezni.

A QT/QTL érzékelő beállítása szintén kézzel történik. Amennyiben minimum vagy maximum beállítás szükséges (végállások) javasolt az érzékelő beállító gombját az ütközéstől számítva egy kicsit visszaforgatni.

**Kérjük, vegye figyelembe, hogy a mellékelt táblázatok csak jelzésértékűek, és az alkalmazástól függően változnak. Csak útmutatóként használhatók. A pontos hőmérséklet-ellenőrzéshez a hőmérsékletet a referenciaponton kell mérni, és az érzékelőt ennek megfelelően kell beállítani.**

**AB-QM DN 10-20 (35-50 °C)**

Hőmérséklet beállítás (°C)	QT érzékelő beállítás (fordulat)						
	0	1	2	3	4	5	6
20 %	38.0	40.5	43.0	45.5	48.0	50.5	53.0
30 %	37.0	39.5	42.0	44.5	47.0	49.5	52.0
40 %	36.0	38.5	41.0	43.5	46.0	48.5	51.0
50 %	35.0	37.5	40.0	42.5	45.0	47.5	50.0
60 %	34.0	36.5	39.0	41.5	44.0	46.5	49.0
70 %	33.0	35.5	38.0	40.5	43.0	45.5	48.0
80 %	32.0	34.5	37.0	39.5	42.0	44.5	47.0
90 %	31.0	33.5	36.0	38.5	41.0	43.5	46.0
100 %	30.0	32.5	35.0	37.5	40.0	42.5	45.0

QT érzékelő gyári beállítása "4"

**AB-QM DN 10-20 (45-60 °C)**

Hőmérséklet beállítás (°C)	QT érzékelő beállítás (fordulat)						
	0	1	2	3	4	5	6
20 %	48.0	50.5	53.0	55.5	58.0	60.5	63.0
30 %	47.0	49.5	52.0	54.5	57.0	59.5	62.0
40 %	46.0	48.5	51.0	53.5	56.0	58.5	61.0
50 %	45.0	47.5	50.0	52.5	55.0	57.5	60.0
60 %	44.0	46.5	49.0	51.5	54.0	56.5	59.0
70 %	43.0	45.5	48.0	50.5	53.0	55.5	58.0
80 %	42.0	44.5	47.0	49.5	52.0	54.5	57.0
90 %	41.0	43.5	46.0	48.5	51.0	53.5	56.0
100 %	40.0	42.5	45.0	47.5	50.0	52.5	55.0

QT érzékelő gyári beállítása "4"

**AB-QM DN 10-20 (65-85 °C)**

Hőmérséklet beállítás (°C)	QT érzékelő beállítás (fordulat)						
	0	1	2	3	4	5	6
20 %	68.5	71.0	73.5	76.5	80.0	83.5	87.5
30 %	67.0	70.0	72.5	76.0	79.0	82.5	86.5
40 %	66.0	69.0	71.5	75.0	78.5	81.5	85.5
50 %	65.0	68.0	71.0	74.5	77.5	81.0	85.0
60 %	63.5	67.0	70.5	74.0	76.5	80.0	84.0
70 %	62.0	65.5	69.0	72.5	75.5	79.0	83.5
80 %	60.5	64.0	67.5	71.0	74.5	78.0	83.0
90 %	58.5	62.5	66.0	69.5	73.5	77.5	82.0
100 %	57.0	61.0	64.5	68.0	72.5	77.0	81.5

QT érzékelő gyári beállítása "4"

**AB-QM DN 25-32 (35-50 °C)**

Hőmérséklet beállítás (°C)	QT érzékelő beállítás (fordulat)						
	0	1	2	3	4	5	6
20 %	39.5	42.0	44.5	47.0	49.5	52.0	54.5
30 %	38.0	40.5	43.0	45.5	48.0	50.5	53.0
40 %	36.5	39.0	41.5	44.0	46.5	49.0	51.5
50 %	35.0	37.5	40.0	42.5	45.0	47.5	50.0
60 %	33.5	36.0	38.5	41.0	43.5	46.0	48.5
70 %	32.0	34.5	37.0	39.5	42.0	44.5	47.0
80 %	30.5	33.0	35.5	38.0	40.5	43.0	45.5
90 %	29.0	31.5	34.0	36.5	39.0	41.5	44.0
100 %	27.5	30.0	32.5	35.0	37.5	40.0	42.5

QT érzékelő gyári beállítása "4"

**AB-QM DN 25-32 (45-60 °C)**

Hőmérséklet beállítás (°C)	QT érzékelő beállítás (fordulat)						
	0	1	2	3	4	5	6
20 %	49.5	52.0	54.5	57.0	59.5	62.0	64.5
30 %	48.0	50.5	53.0	55.5	58.0	60.5	63.0
40 %	46.5	49.0	51.5	54.0	56.5	59.0	61.5
50 %	45.0	47.5	50.0	52.5	55.0	57.5	60.0
60 %	43.5	46.0	48.5	51.0	53.5	56.0	58.5
70 %	42.0	44.5	47.0	49.5	52.0	54.5	57.0
80 %	40.5	43.0	45.5	48.0	50.5	53.0	55.5
90 %	39.0	41.5	44.0	46.5	49.0	51.5	54.0
100 %	37.5	40.0	42.5	45.0	47.5	50.0	52.5

QT érzékelő gyári beállítása "4"

**AB-QM DN 25-32 (65-85 °C)**

Hőmérséklet beállítás (°C)	QT érzékelő beállítás (fordulat)						
	0	1	2	3	4	5	6
20 %	72.5	75.0	77.5	80.0	84.0	88.0	92.5
30 %	70.0	73.0	75.5	78.0	82.0	86.0	90.5
40 %	67.5	70.5	73.3	76.0	80.0	83.5	87.0
50 %	65.0	68.0	72.0	74.0	77.5	80.5	85.0
60 %	62.5	65.8	69.2	72.5	76.5	79.0	84.0
70 %	60.0	64.5	68.5	71.5	75.5	78.0	83.0
80 %	58.0	63.0	67.0	70.0	74.0	77.0	81.5
90 %	56.5	61.0	65.0	69.0	72.5	76.5	80.5
100 %	55.0	59.0	63.0	67.5	71.5	75.5	79.5

QT érzékelő gyári beállítása "4"

**POLSKI**
**Wstępny montaż ①**

Umieścić adapter ① w nakrętce głowicy termostatycznej.

**Budowa ②**

Zamontować zawór AB-QM ③ na rurociągu (pionie) (patrz instrukcja zaworu AB-QM).

- ① Głowica nastawy temperatury
- ② Adapter
- ③ Zawór AB-QM
- ④ Rurociąg (pion) centralnego ogrzewania
- ⑤ Czujnik temperatury

Ustawić żądany przepływ na zaworze AB-QM (patrz instrukcja zaworu AB-QM).

**Montaż ③**

Ręcznie zamontować termostat QT/QTL na zaworze AB-QM ( bez użycia klucza ). Maksymalna dopuszczalna siła dokręcania nakrętki to 5 Nm.

**Instalacja czujnika ④**

Zawór AB-QM jest przeznaczony do montażu na rurociągu powrotnym. Czujnik należy zawsze umieszczać w miejscu cieplejszym niż głowica termostatu.

W instalacji jednorurowej zawór AB-QM należy montować za ostatnim grzejnikiem oraz możliwie jak najbliżej niego.

Ręcznie zamontować termostat QT na zaworze AB-QM (bez użycia klucza). Maksymalna dopuszczalna siła dokręcania nakrętki to 5 Nm.

W celu zapewnienia dobrego przewodzenia ciepła pomiędzy medium a czujnikiem temperatury należy użyć termo pasty (załączonej w opakowaniu termostatu), w miejscu montażu czujnika.

Zaleca się izolację czujnika temperatury w miejscach gdzie temperatura otoczenia może być niższa niż 5 °C.

Czujnik temperatury może być montowany w dowolnym kierunku, poniżej lub powyżej głowicy termostatycznej.

- ① Uchwyt czujnika (Sensor holder)
- ② Zapiecie (Fastener)
- ③ Termo pasta (Thermo paste)
- ④ Zasilanie ciepłej wody (Hot water supply)
- ⑤ Najlepsza wydajność (Best performance)

**Nastawa ⑤**

Nastawa elementu termostatycznego QT/QTL zależy od nastawy przepływu na zaworze AB-QM.

Konieczne jest wykonanie nastawy przepływu na zaworze AB-QM przed zamontowaniem termostatu QT/QTL. Zaleca się taki dobór zaworów AB-QM aby nastawa mieściła się w zakresie od 30 do 70 % maksymalnego przepływu dla danej średnicy.

Nastawy termostatu QT/QTL dokonuje się bez użycia dodatkowych narzędzi, poprzez obrót głowicy odpowiednio na żadaną wartość temperatury.

Należy pamiętać, że załączone tabele mają charakter orientacyjny, a rzeczywiste wartości zależą od zastosowania. Podane informacje służą jako wskazówki. W celu dokładnej weryfikacji temperatury zmierzyc ją w punkcie odniesienia i odpowiednio wyregulować czujnik.

**AB-QM DN 10-20 (35-50 °C)**

Nastawa temperatury (°C)	QT nastawa termostatu (obroty)						
	0	1	2	3	4	5	6
20 %	38.0	40.5	43.0	45.5	48.0	50.5	53.0
30 %	37.0	39.5	42.0	44.5	47.0	49.5	52.0
40 %	36.0	38.5	41.0	43.5	46.0	48.5	51.0
50 %	35.0	37.5	40.0	42.5	45.0	47.5	50.0
60 %	34.0	36.5	39.0	41.5	44.0	46.5	49.0
70 %	33.0	35.5	38.0	40.5	43.0	45.5	48.0
80 %	32.0	34.5	37.0	39.5	42.0	44.5	47.0
90 %	31.0	33.5	36.0	38.5	41.0	43.5	46.0
100 %	30.0	32.5	35.0	37.5	40.0	42.5	45.0

Nastawa fabryczna termostatu: 4

**AB-QM DN 10-20 (45-60 °C)**

Nastawa temperatury (°C)	QT nastawa termostatu (obroty)						
	0	1	2	3	4	5	6
20 %	48.0	50.5	53.0	55.5	58.0	60.5	63.0
30 %	47.0	49.5	52.0	54.5	57.0	59.5	62.0
40 %	46.0	48.5	51.0	53.5	56.0	58.5	61.0
50 %	45.0	47.5	50.0	52.5	55.0	57.5	60.0
60 %	44.0	46.5	49.0	51.5	54.0	56.5	59.0
70 %	43.0	45.5	48.0	50.5	53.0	55.5	58.0
80 %	42.0	44.5	47.0	49.5	52.0	54.5	57.0
90 %	41.0	43.5	46.0	48.5	51.0	53.5	56.0
100 %	40.0	42.5	45.0	47.5	50.0	52.5	55.0

Nastawa fabryczna termostatu: 4

**AB-QM DN 10-20 (65-85 °C)**

Nastawa temperatury (°C)	QT nastawa termostatu (obroty)						
	0	1	2	3	4	5	6
20 %	68.5	71.0	73.5	76.0	78.5	81.0	83.5
30 %	67.0	70.0	72.5	75.0	77.5	80.0	82.5
40 %	66.0	69.0	71.5	74.0	76.5	79.0	81.5
50 %	65.0	68.0	70.5	73.0	75.5	78.0	80.5
60 %	63.5	67.0	70.5	74.0	77.5	81.0	84.5
70 %	62.0	65.5	69.0	72.5	76.0	79.5	83.0
80 %	60.5	64.0	67.5	71.0	74.5	78.0	81.5
90 %	58.5	62.5	66.0	69.5	73.0	76.5	80.0
100 %	57.0	61.0	64.5	68.0	71.5	75.0	78.5

Nastawa fabryczna termostatu: 4

**AB-QM DN 25-32 (35-50 °C)**

Nastawa temperatury (°C)	QT nastawa termostatu (obroty)						
	0	1	2	3	4	5	6
20 %	39.5	42.0	44.5	47.0	49.5	52.0	54.5
30 %	38.0	40.5	43.0	45.5	48.0	50.5	53.0
40 %	36.5	39.0	41.5	44.0	46.5	49.0	51.5
50 %	35.0	37.5	40.0	42.5	45.0	47.5	50.0
60 %	33.5	36.0	38.5	41.0	43.5	46.0	48.5
70 %	32.0	34.5	37.0	39.5	42.0	44.5	47.0
80 %	30.5	33.0	35.5	38.0	40.5	43.0	45.5
90 %	29.0	31.5	34.0	36.5	39.0	41.5	44.0
100 %	27.5	30.0	32.5	35.0	37.5	40.0	42.5

Nastawa fabryczna termostatu: 4

**AB-QM DN 25-32 (45-60 °C)**

Nastawa temperatury (°C)	QT nastawa termostatu (obroty)						
	0	1	2	3	4	5	6
20 %	49.5	52.0	54.5	57.0	59.5	62.0	64.5
30 %	48.0	50.5	53.0	55.5	58.0	60.5	63.0
40 %	46.5	49.0	51.5	54.0	56.5	59.0	61.5
50 %	45.0	47.5	50.0	52.5	55.0	57.5	60.0
60 %	43.5	46.0	48.5	51.0	53.5	56.0	58.5
70 %	42.0	44.5	47.0	49.5	52.0	54.5	57.0
80 %	40.5	43.0	45.5	48.0	50.5	53.0	55.5
90 %	39.0	41.5	44.0	46.5	49.0	51.5	54.0
100 %	37.5	40.0	42.5	45.0	47.5	50.0	52.5

Nastawa fabryczna termostatu: 4

**AB-QM DN 25-32 (65-85 °C)**

Nastawa temperatury (°C)	QT nastawa termostatu (obroty)						
	0	1	2	3	4	5	6
20 %	72.5	75.0	77.5	80.0	82.5	85.0	87.5
30 %	70.0	73.0	75.5	78.0	80.5	83.0	85.5
40 %	67.5	70.5	73.5	76.0	78.5	81.0	83.5
50 %	65.0	68.0	71.0	74.0	77.0	80.0	83.0
60 %	62.5	65.8	69.2	72.5	75.8	79.2	82.5
70 %	60.0	64.5	68.5	71.5	75.5	79.0	82.5
80 %	58.0	63.0	67.0	70.0	74.0	77.0	81.0
90 %	56.5	61.0	65.0	69.0	72.5	76.5	80.5
100 %	55.0	59.0	63.0	67.5	71.5	75.5	79.5

Nastawa fabryczna termostatu: 4

**РУССКИЙ**
**Порядок установки ①**

Вставьте адаптер ① внутрь термоэлемента

**Устройство ②**

Установите клапан АВ-QM ③ на стояке однострунной системы отопления (см. инструкцию АВ-QM)

- ① Настроечная рукоятка
- ② Присоединительная гайка
- ③ Клапан АВ-QM
- ④ Стояк системы отопления
- ⑤ Температурный датчик

Установите требуемую настройку клапана АВ-QM (см. инструкцию АВ-QM)

**Монтаж ③**

Установите термоэлемент QT/QTL на клапан АВ-QM вручную. Установка должна происходить без использования инструментов! Макс. крутящий момент не должен превышать 5 Нм.

**Установка датчика температуры ④**

Датчик АВ-QM должен устанавливаться на обратном трубопроводе. Как правило, датчик всегда должен устанавливаться так, чтобы температура в нём была выше температуры в головке термостата.

В случае однострунной системы датчик АВ-QM необходимо устанавливать за последним радиатором на минимальном от него расстоянии.

Термоэлемент QT следует устанавливать на клапаны вручную не превышая крутящий момент 5Нм.

Для улучшения теплопередачи от трубы стояка к температурному датчику следует обязательно использовать термо-гель (входит в комплект поставки термоэлемента, в коробке) между стояком и контактной стороной датчика.

Рекомендуется также закрыть датчик теплоизоляцией; обязательно, если датчик установлен в холодном помещении с температурой менее 5 °С.

Датчик может быть установлен в любом положении, выше или ниже клапана. Для оптимального регулирования рекомендуется устанавливать выше термоэлемента.

- ① Кожух датчика (Sensor holder)
- ② Крепежные пазы (Fastener)
- ③ Термо-гель (Thermo paste)
- ④ Направление движения теплоносителя (Hot water supply)
- ⑤ Наилучшая эффективность (Best performance)

**Настройка термоэлемента ⑤**

Настройка термоэлемента QT/QTL зависит от настройки клапана АВ-QM.

Первым действием должна быть настройка клапан АВ-QM на требуемый расход. Для оптимального регулирования термоэлемента, настройки клапана рекомендуются в диапазоне 30 – 70 %.

Термостат QT/QTL настраивается на требуемую температуру вручную, поворотом рукоятки. Если требуется максимальные, либо минимальные настройки, после выполненной процедуры рекомендуется на четверть повернуть настроечную рукоятку в сторону противоположную настройке. Это обеспечит наилучшую работу термоэлемента.

**Пожалуйста, имейте в виду, что прилагаемые таблицы являются ориентировочными и варьируются в зависимости от области применения. Они предназначены для использования в качестве руководства. Для обеспечения точности проверки температуры температура должна быть измерена в референсной точке и в соответствии с этим должен быть настроен датчик.**

**АВ-QM Ду = 10-20 мм (35-50 °С)**

Температурная настройка	Настройка термоэлемента QT (обороты)							
	0	1	2	3	4	5	6	
Настройка клапана АВ-QM	20 %	38.0	40.5	43.0	45.5	48.0	50.5	53.0
	30 %	37.0	39.5	42.0	44.5	47.0	49.5	52.0
	40 %	36.0	38.5	41.0	43.5	46.0	48.5	51.0
	50 %	35.0	37.5	40.0	42.5	45.0	47.5	50.0
	60 %	34.0	36.5	39.0	41.5	44.0	46.5	49.0
	70 %	33.0	35.5	38.0	40.5	43.0	45.5	48.0
	80 %	32.0	34.5	37.0	39.5	42.0	44.5	47.0
	90 %	31.0	33.5	36.0	38.5	41.0	43.5	46.0
	100 %	30.0	32.5	35.0	37.5	40.0	42.5	45.0

Заводская настройка термоэлемента 4.

**АВ-QM Ду = 10-20 мм (45-60 °С)**

Температурная настройка	Настройка термоэлемента QT (обороты)							
	0	1	2	3	4	5	6	
Настройка клапана АВ-QM	20 %	48.0	50.5	53.0	55.5	58.0	60.5	63.0
	30 %	47.0	49.5	52.0	54.5	57.0	59.5	62.0
	40 %	46.0	48.5	51.0	53.5	56.0	58.5	61.0
	50 %	45.0	47.5	50.0	52.5	55.0	57.5	60.0
	60 %	44.0	46.5	49.0	51.5	54.0	56.5	59.0
	70 %	43.0	45.5	48.0	50.5	53.0	55.5	58.0
	80 %	42.0	44.5	47.0	49.5	52.0	54.5	57.0
	90 %	41.0	43.5	46.0	48.5	51.0	53.5	56.0
	100 %	40.0	42.5	45.0	47.5	50.0	52.5	55.0

Заводская настройка термоэлемента 4.

**АВ-QM Ду = 10-20 мм (65-85 °С)**

Температурная настройка	Настройка термоэлемента QT (обороты)							
	0	1	2	3	4	5	6	
Настройка клапана АВ-QM	20 %	68.5	71.0	73.5	76.5	80.0	83.5	87.5
	30 %	67.0	70.0	72.5	76.0	79.0	82.5	86.5
	40 %	66.0	69.0	71.5	75.0	78.5	81.5	85.5
	50 %	65.0	68.0	71.0	74.5	77.5	81.0	85.0
	60 %	63.5	67.0	70.5	74.0	76.5	80.0	84.0
	70 %	62.0	65.5	69.0	72.5	75.5	79.0	83.5
	80 %	60.5	64.0	67.5	71.0	74.5	78.0	83.0
	90 %	58.5	62.5	66.0	69.5	73.5	77.5	82.0
	100 %	57.0	61.0	64.5	68.0	72.5	77.0	81.5

Заводская настройка термоэлемента 4.

**АВ-QM Ду = 25-32 мм (35-50 °С)**

Температурная настройка	Настройка термоэлемента QT (обороты)							
	0	1	2	3	4	5	6	
Настройка клапана АВ-QM	20 %	39.5	42.0	44.5	47.0	49.5	52.0	54.5
	30 %	38.0	40.5	43.0	45.5	48.0	50.5	53.0
	40 %	36.5	39.0	41.5	44.0	46.5	49.0	51.5
	50 %	35.0	37.5	40.0	42.5	45.0	47.5	50.0
	60 %	33.5	36.0	38.5	41.0	43.5	46.0	48.5
	70 %	32.0	34.5	37.0	39.5	42.0	44.5	47.0
	80 %	30.5	33.0	35.5	38.0	40.5	43.0	45.5
	90 %	29.0	31.5	34.0	36.5	39.0	41.5	44.0
	100 %	27.5	30.0	32.5	35.0	37.5	40.0	42.5

Заводская настройка термоэлемента 4.

**АВ-QM Ду = 25-32 мм (45-60 °С)**

Температурная настройка	Настройка термоэлемента QT (обороты)							
	0	1	2	3	4	5	6	
Настройка клапана АВ-QM	20 %	49.5	52.0	54.5	57.0	59.5	62.0	64.5
	30 %	48.0	50.5	53.0	55.5	58.0	60.5	63.0
	40 %	46.5	49.0	51.5	54.0	56.5	59.0	61.5
	50 %	45.0	47.5	50.0	52.5	55.0	57.5	60.0
	60 %	43.5	46.0	48.5	51.0	53.5	56.0	58.5
	70 %	42.0	44.5	47.0	49.5	52.0	54.5	57.0
	80 %	40.5	43.0	45.5	48.0	50.5	53.0	55.5
	90 %	39.0	41.5	44.0	46.5	49.0	51.5	54.0
	100 %	37.5	40.0	42.5	45.0	47.5	50.0	52.5

Заводская настройка термоэлемента 4.

**АВ-QM Ду = 25-32 мм (65-85 °С)**

Температурная настройка	Настройка термоэлемента QT (обороты)							
	0	1	2	3	4	5	6	
Настройка клапана АВ-QM	20 %	72.5	75.0	77.5	80.0	84.0	88.0	92.5
	30 %	70.0	73.0	75.5	78.0	82.0	86.0	90.5
	40 %	67.5	70.5	73.3	76.0	80.0	83.5	87.0
	50 %	65.0	68.0	72.0	74.0	77.5	80.5	85.0
	60 %	62.5	65.8	69.2	72.5	76.5	79.0	84.0
	70 %	60.0	64.5	68.5	71.5	75.5	78.0	83.0
	80 %	58.0	63.0	67.0	70.0	74.0	77.0	81.5
	90 %	56.5	61.0	65.0	69.0	72.5	76.5	80.5
	100 %	55.0	59.0	63.0	67.5	71.5	75.5	79.5

Заводская настройка термоэлемента 4.

**中文**
**安装说明 ①**

将连接适配器 ① 插入温控器下方

**设计 ②**

将AB-QM阀体 ③ 连接到热水水管上  
(见AB-QM 安装说明)

- ① 设定手轮
- ② 适配器
- ③ AB-QM 阀体
- ④ 热水水管
- ⑤ 温度传感器

将AB-QM设定到所需要的流量上  
(见AB-QM安装说明)

**安装 ③**

将QT/QTL 用手轻柔缓慢安装到AB-QM上, 扭矩不超过5 Nm

**温度传感器安装 ④**

AB-QM 应该安装在回水管道上。一般来说, 传感器安装位置的温度必须始终高于温控器顶部。

在单管系统中, AB-QM 需要安装在最后一个散热器之后且尽可能与之接近的位置。

QT 应当用手轻柔安装到AB-QM上, 扭矩不超过5 Nm

为了使温度传感器更好的感知水管温度, 一定要在传感器和热水管接触面上使用导热胶(产品自带)

如果传感器安装位置环境温度低于5 °C强烈建议对温度传感器做保温处理

传感器需要和管道同向安装, 安装位置在QT温控器的上下均可

- ① 传感器卡套 (Sensor holder)
- ② 固定器 (Fastener)
- ③ 热粘合 (Thermo paste)
- ④ 热水供应 (Hot water supply)
- ⑤ 最佳效果 (Best performance)

**QT/QTL温控器的设定 ⑤**

QT/QTL 温控器的设定基于AB-QM阀门的流量设定

应当在安装温控器前先设定AB-QM的流量, 推荐AB-QM的流量设定范围在30%~70%

QT/QTL温控器可以直接用手来设定, 不需要特殊工具 当QT/QTL温控器需要设定到最大值或者最小值时, 可以将设定手轮在到底后往相反方向复位一点, 这样可以保证QT温控器的最佳性能

请注意, 附表只是指示性的, 针对不同应用场合, 可能有所差别。仅用于指导使用。精确的温度测量验证, 需要将温度传感器设定在参考点上并进行校准。

**AB-QM DN 10-20 (35-50 °C)**

温度设定 (°C)	QT 温控器设定 (圈数)						
	0	1	2	3	4	5	6
20 %	38.0	40.5	43.0	45.5	48.0	50.5	53.0
30 %	37.0	39.5	42.0	44.5	47.0	49.5	52.0
40 %	36.0	38.5	41.0	43.5	46.0	48.5	51.0
50 %	35.0	37.5	40.0	42.5	45.0	47.5	50.0
60 %	34.0	36.5	39.0	41.5	44.0	46.5	49.0
70 %	33.0	35.5	38.0	40.5	43.0	45.5	48.0
80 %	32.0	34.5	37.0	39.5	42.0	44.5	47.0
90 %	31.0	33.5	36.0	38.5	41.0	43.5	46.0
100 %	30.0	32.5	35.0	37.5	40.0	42.5	45.0

工厂默认QT温控器设定值为4

**AB-QM DN 10-20 (45-60 °C)**

温度设定 (°C)	QT 温控器设定 (圈数)						
	0	1	2	3	4	5	6
20 %	48.0	50.5	53.0	55.5	58.0	60.5	63.0
30 %	47.0	49.5	52.0	54.5	57.0	59.5	62.0
40 %	46.0	48.5	51.0	53.5	56.0	58.5	61.0
50 %	45.0	47.5	50.0	52.5	55.0	57.5	60.0
60 %	44.0	46.5	49.0	51.5	54.0	56.5	59.0
70 %	43.0	45.5	48.0	50.5	53.0	55.5	58.0
80 %	42.0	44.5	47.0	49.5	52.0	54.5	57.0
90 %	41.0	43.5	46.0	48.5	51.0	53.5	56.0
100 %	40.0	42.5	45.0	47.5	50.0	52.5	55.0

工厂默认QT温控器设定值为4

**AB-QM DN 10-20 (65-85 °C)**

温度设定 (°C)	QT 温控器设定 (圈数)						
	0	1	2	3	4	5	6
20 %	68.5	71.0	73.5	76.5	80.0	83.5	87.5
30 %	67.0	70.0	72.5	76.0	79.0	82.5	86.5
40 %	66.0	69.0	71.5	75.0	78.5	81.5	85.5
50 %	65.0	68.0	71.0	74.5	77.5	81.0	85.0
60 %	63.5	67.0	70.5	74.0	76.5	80.0	84.0
70 %	62.0	65.5	69.0	72.5	75.5	79.0	83.5
80 %	60.5	64.0	67.5	71.0	74.5	78.0	83.0
90 %	58.5	62.5	66.0	69.5	73.5	77.5	82.0
100 %	57.0	61.0	64.5	68.0	72.5	77.0	81.5

工厂默认QT温控器设定值为4

**AB-QM DN 25-32 (35-50 °C)**

温度设定 (°C)	QT 温控器设定 (圈数)						
	0	1	2	3	4	5	6
20 %	39.5	42.0	44.5	47.0	49.5	52.0	54.5
30 %	38.0	40.5	43.0	45.5	48.0	50.5	53.0
40 %	36.5	39.0	41.5	44.0	46.5	49.0	51.5
50 %	35.0	37.5	40.0	42.5	45.0	47.5	50.0
60 %	33.5	36.0	38.5	41.0	43.5	46.0	48.5
70 %	32.0	34.5	37.0	39.5	42.0	44.5	47.0
80 %	30.5	33.0	35.5	38.0	40.5	43.0	45.5
90 %	29.0	31.5	34.0	36.5	39.0	41.5	44.0
100 %	27.5	30.0	32.5	35.0	37.5	40.0	42.5

工厂默认QT温控器设定值为4

**AB-QM DN 25-32 (45-60 °C)**

温度设定 (°C)	QT 温控器设定 (圈数)						
	0	1	2	3	4	5	6
20 %	49.5	52.0	54.5	57.0	59.5	62.0	64.5
30 %	48.0	50.5	53.0	55.5	58.0	60.5	63.0
40 %	46.5	49.0	51.5	54.0	56.5	59.0	61.5
50 %	45.0	47.5	50.0	52.5	55.0	57.5	60.0
60 %	43.5	46.0	48.5	51.0	53.5	56.0	58.5
70 %	42.0	44.5	47.0	49.5	52.0	54.5	57.0
80 %	40.5	43.0	45.5	48.0	50.5	53.0	55.5
90 %	39.0	41.5	44.0	46.5	49.0	51.5	54.0
100 %	37.5	40.0	42.5	45.0	47.5	50.0	52.5

工厂默认QT温控器设定值为4

**AB-QM DN 25-32 (65-85 °C)**

温度设定 (°C)	QT 温控器设定 (圈数)						
	0	1	2	3	4	5	6
20 %	72.5	75.0	77.5	80.0	84.0	88.0	92.5
30 %	70.0	73.0	75.5	78.0	82.0	86.0	90.5
40 %	67.5	70.5	73.3	76.0	80.0	83.5	87.0
50 %	65.0	68.0	72.0	74.0	77.5	80.5	85.0
60 %	62.5	65.8	69.2	72.5	76.5	79.0	84.0
70 %	60.0	64.5	68.5	71.5	75.5	78.0	83.0
80 %	58.0	63.0	67.0	70.0	74.0	77.0	81.5
90 %	56.5	61.0	65.0	69.0	72.5	76.5	80.5
100 %	55.0	59.0	63.0	67.5	71.5	75.5	79.5

工厂默认QT温控器设定值为4

## Thermostatic actuator QT / QTL

### ČESKY

#### Sestavení ①

Vložte adaptér ① do hrdla termostatického pohonu

#### Konstrukce ②

Namontujte ventil AB-QM ③ do potrubí (viz pokyny pro ventil AB-QM)

- ① Nastavovací otočná hlavice
- ② Adaptér
- ③ Ventil AB-QM
- ④ Potrubí teplé vody
- ⑤ Teplotní čidlo

Proveďte požadované nastavení na ventilu AB-QM (viz pokyny pro ventil AB-QM)

#### Montáž ③

Termostat QT/QTL se ručně namontuje na ventil AB-QM. Maximální přípustný utahovací moment je 5 Nm.

#### Instalace čidla ④

Ventil AB-QM je třeba nainstalovat na vratné potrubí. Obecně musí být snímač umístěn vždy na teplejším místě než hlava termostatu.

V případě systému s jednou trubkou je třeba ventil AB-QM nainstalovat za poslední radiátor a co nejlíže k němu.

Termostat QT se ručně namontuje na ventil AB-QM. Maximální přípustný utahovací moment je 5 Nm.

Pro správný přenos tepla mezi potrubím s teplou vodou a termostatickým čidlem je velmi důležité nanést termo pastu (přiložena v krabici) na styčné plochy.

Pokud je termostat instalován na velmi chladném místě (<5 °C), doporučuje se čidlo zaizolovat.

Samotné čidlo lze namontovat v libovolném směru. Lze jej namontovat nad nebo pod hlavu čidla.

- ① Držák čidla (Sensor holder)
- ② Příchytky (Fastener)
- ③ Termo pasta (Thermo paste)
- ④ Přívod teplé vody (Hotwater supply)
- ⑤ Nejlepší výkon (Best performance)

#### Nastavení ⑤

Nastavení teploty na termostatu QT/QTL závisí na nastavení průtoku ventilu AB-QM.

Požadované nastavení ventilu AB-QM je třeba provést před montáží termostatu. Doporučuje se nastavit ventil AB-QM na průtok 30 až 70 %.

Nastavení termostatu QT/QTL se provádí ručně. Při nastavování na minimální nebo maximální hodnotu posuňte hlavici termostatu QT/QTL nepatrně opačným směrem, abyste zajistili optimální funkčnost termostatu.

Prosím, berte na zřetel, že přiložené tabulky jsou orientační a budou se lišit v závislosti na aplikaci. Jsou pro použití pouze jako vodítko. Pro přesné ověření teploty je třeba teplotu měřit v referenčním bodě a dle toho nastavit snímač.

#### AB-QM DN 10-20 (35-50 °C)

Nastavení teploty (°C)	Nastavení čidla QT (stupně otočení)						
	0	1	2	3	4	5	6
20 %	38.0	40.5	43.0	45.5	48.0	50.5	53.0
30 %	37.0	39.5	42.0	44.5	47.0	49.5	52.0
40 %	36.0	38.5	41.0	43.5	46.0	48.5	51.0
50 %	35.0	37.5	40.0	42.5	45.0	47.5	50.0
60 %	34.0	36.5	39.0	41.5	44.0	46.5	49.0
70 %	33.0	35.5	38.0	40.5	43.0	45.5	48.0
80 %	32.0	34.5	37.0	39.5	42.0	44.5	47.0
90 %	31.0	33.5	36.0	38.5	41.0	43.5	46.0
100 %	30.0	32.5	35.0	37.5	40.0	42.5	45.0

Výrobní nastavení termostatu je 4.

#### AB-QM DN 10-20 (45-60 °C)

Nastavení teploty (°C)	Nastavení čidla QT (otáčky)						
	0	1	2	3	4	5	6
20 %	48.0	50.5	53.0	55.5	58.0	60.5	63.0
30 %	47.0	49.5	52.0	54.5	57.0	59.5	62.0
40 %	46.0	48.5	51.0	53.5	56.0	58.5	61.0
50 %	45.0	47.5	50.0	52.5	55.0	57.5	60.0
60 %	44.0	46.5	49.0	51.5	54.0	56.5	59.0
70 %	43.0	45.5	48.0	50.5	53.0	55.5	58.0
80 %	42.0	44.5	47.0	49.5	52.0	54.5	57.0
90 %	41.0	43.5	46.0	48.5	51.0	53.5	56.0
100 %	40.0	42.5	45.0	47.5	50.0	52.5	55.0

Výrobní nastavení termostatu je 4.

#### AB-QM DN 10-20 (65-85 °C)

Nastavení teploty (°C)	Nastavení čidla QT (otáčky)						
	0	1	2	3	4	5	6
20 %	68.5	71.0	73.5	76.5	80.0	83.5	87.5
30 %	67.0	70.0	72.5	76.0	79.0	82.5	86.5
40 %	66.0	69.0	71.5	75.0	78.5	81.5	85.5
50 %	65.0	68.0	71.0	74.5	77.5	81.0	85.0
60 %	63.5	67.0	70.5	74.0	76.5	80.0	84.0
70 %	62.0	65.5	69.0	72.5	75.5	79.0	83.5
80 %	60.5	64.0	67.5	71.0	74.5	78.0	83.0
90 %	58.5	62.5	66.0	69.5	73.5	77.5	82.0
100 %	57.0	61.0	64.5	68.0	72.5	77.0	81.5

Výrobní nastavení termostatu je 4.

#### AB-QM DN 25-32 (35-50 °C)

Nastavení teploty (°C)	Nastavení čidla QT (stupně otočení)						
	0	1	2	3	4	5	6
20 %	39.5	42.0	44.5	47.0	49.5	52.0	54.5
30 %	38.0	40.5	43.0	45.5	48.0	50.5	53.0
40 %	36.5	39.0	41.5	44.0	46.5	49.0	51.5
50 %	35.0	37.5	40.0	42.5	45.0	47.5	50.0
60 %	33.5	36.0	38.5	41.0	43.5	46.0	48.5
70 %	32.0	34.5	37.0	39.5	42.0	44.5	47.0
80 %	30.5	33.0	35.5	38.0	40.5	43.0	45.5
90 %	29.0	31.5	34.0	36.5	39.0	41.5	44.0
100 %	27.5	30.0	32.5	35.0	37.5	40.0	42.5

Výrobní nastavení termostatu je 4.

#### AB-QM DN 25-32 (45-60 °C)

Nastavení teploty (°C)	Nastavení čidla QT (stupně otočení)						
	0	1	2	3	4	5	6
20 %	49.5	52.0	54.5	57.0	59.5	62.0	64.5
30 %	48.0	50.5	53.0	55.5	58.0	60.5	63.0
40 %	46.5	49.0	51.5	54.0	56.5	59.0	61.5
50 %	45.0	47.5	50.0	52.5	55.0	57.5	60.0
60 %	43.5	46.0	48.5	51.0	53.5	56.0	58.5
70 %	42.0	44.5	47.0	49.5	52.0	54.5	57.0
80 %	40.5	43.0	45.5	48.0	50.5	53.0	55.5
90 %	39.0	41.5	44.0	46.5	49.0	51.5	54.0
100 %	37.5	40.0	42.5	45.0	47.5	50.0	52.5

Výrobní nastavení termostatu je 4.

#### AB-QM DN 25-32 (65-85 °C)

Nastavení teploty (°C)	Nastavení čidla QT (stupně otočení)						
	0	1	2	3	4	5	6
20 %	72.5	75.0	77.5	80.0	84.0	88.0	92.5
30 %	70.0	73.0	75.5	78.0	82.0	86.0	90.5
40 %	67.5	70.5	73.3	76.0	80.0	83.5	87.0
50 %	65.0	68.0	72.0	74.0	77.5	80.5	85.0
60 %	62.5	65.8	69.2	72.5	76.5	79.0	84.0
70 %	60.0	64.5	68.5	71.5	75.5	78.0	83.0
80 %	58.0	63.0	67.0	70.0	74.0	77.0	81.5
90 %	56.5	61.0	65.0	69.0	72.5	76.5	80.5
100 %	55.0	59.0	63.0	67.5	71.5	75.5	79.5

Výrobní nastavení termostatu je 4.

## Thermostatic actuator QT / QTL

### EESTI

#### Kokkupanek ①

Ühenda adapter ① termostaadiga

#### Ehitus ②

Paigalda AB-QM ventiil ③ kütteeve torule (vt AB-QM instruksiooni)

- ① Seadistamise käepide
- ② Adapter
- ③ AB-QM ventiil
- ④ Kütteeve toru
- ⑤ Temperatuuriandur

Seadke AB-QM ventiilil soovitud seade (vt AB-QM instruksioonist)

#### Paigaldamine ③

QT/QTL tuleb paigaldada AB-QM ventiilile käsitsi. Suurim lubatud pöördemoment on 5 Nm.

#### Anduri paigaldamine ④

AB-QM tuleb paigaldada tagasivoolutorule. Üldiselt tuleb andur alati paigutada termostaadipeast soojemasse kohta.

Ühetorusüsteemi korral tuleb AB-QM paigaldada viimase radiaatori järel ja sellele võimalikult lähedale.

QT tuleb paigaldada AB-QM ventiilile käsitsi. Suurim lubatud pöördemoment on 5 Nm.

Laitmatuks soojusülekaneks toru ja termostaatanduri vahel on väga oluline kokkupuutuvatel pindadel kasutada termopastat (karbis kaasas).

Kui termostaat on paigaldatud väga külma kohta (< 5 °C), on soovitatav andur isoleerida.

Andurit ise võib paigaldada mis tahes asendis. Selle võib paigaldada suunaga ülespoole või allapoole.

- ① Anduri hoidik (Sensor holder)
- ② Kinnitus (Fastener)
- ③ Termopasta (Thermo paste)
- ④ Kütte pealevool (Hotwater supply)
- ⑤ Parim tulemus (Best performance)

#### Seadistamine ⑤

QT/QTL temperatuuri seade sõltub AB-QM vooluhulga seadest.

Enne termostaadi paigaldamist on vaja seadistada AB-QM soovitud suurusele. Soovitatav on seadistada AB-QM 30 ja 70 % vahele vooluhulga seadest.

QT/QTL termostaat seatakse käsitsi soovitud suurusele. Kui on vajalik miinimum või maksimum seadesuurus, keeratakse seadistamise käepidet veidi vastassuunas, et tagada termostaadi optimaalne töö.

**Tähelepanu!** Lisatud tabelid on soovituslikud ja on erinevad sõltuvalt rakendusest. Neid tuleb kasutada ainult juhendamiseks. Täpseks temperatuurikontrollimiseks tuleb temperatuuri mõõta võrdluspunkti ja andur vastavalt seadistada.

#### AB-QM DN 10-20 (35-50 °C)

Temp. seade (°C)	QT anduri seade (pööret)						
	0	1	2	3	4	5	6
20 %	38.0	40.5	43.0	45.5	48.0	50.5	53.0
30 %	37.0	39.5	42.0	44.5	47.0	49.5	52.0
40 %	36.0	38.5	41.0	43.5	46.0	48.5	51.0
50 %	35.0	37.5	40.0	42.5	45.0	47.5	50.0
60 %	34.0	36.5	39.0	41.5	44.0	46.5	49.0
70 %	33.0	35.5	38.0	40.5	43.0	45.5	48.0
80 %	32.0	34.5	37.0	39.5	42.0	44.5	47.0
90 %	31.0	33.5	36.0	38.5	41.0	43.5	46.0
100 %	30.0	32.5	35.0	37.5	40.0	42.5	45.0

Termostaadi tehaseseade on 4.

#### AB-QM DN 10-20 (45-60 °C)

Temp. seade (°C)	QT anduri seade (pööret)						
	0	1	2	3	4	5	6
20 %	48.0	50.5	53.0	55.5	58.0	60.5	63.0
30 %	47.0	49.5	52.0	54.5	57.0	59.5	62.0
40 %	46.0	48.5	51.0	53.5	56.0	58.5	61.0
50 %	45.0	47.5	50.0	52.5	55.0	57.5	60.0
60 %	44.0	46.5	49.0	51.5	54.0	56.5	59.0
70 %	43.0	45.5	48.0	50.5	53.0	55.5	58.0
80 %	42.0	44.5	47.0	49.5	52.0	54.5	57.0
90 %	41.0	43.5	46.0	48.5	51.0	53.5	56.0
100 %	40.0	42.5	45.0	47.5	50.0	52.5	55.0

Termostaadi tehaseseade on 4.

#### AB-QM DN 10-20 (65-85 °C)

Temp. seade (°C)	QT anduri seade (pööret)						
	0	1	2	3	4	5	6
20 %	68.5	71.0	73.5	76.5	80.0	83.5	87.5
30 %	67.0	70.0	72.5	76.0	79.0	82.5	86.5
40 %	66.0	69.0	71.5	75.0	78.5	81.5	85.5
50 %	65.0	68.0	71.0	74.5	77.5	81.0	85.0
60 %	63.5	67.0	70.5	74.0	76.5	80.0	84.0
70 %	62.0	65.5	69.0	72.5	75.5	79.0	83.5
80 %	60.5	64.0	67.5	71.0	74.5	78.0	83.0
90 %	58.5	62.5	66.0	69.5	73.5	77.5	82.0
100 %	57.0	61.0	64.5	68.0	72.5	77.0	81.5

Termostaadi tehaseseade on 4.

#### AB-QM DN 25-32 (35-50 °C)

Temp. seade (°C)	QT anduri seade (pööret)						
	0	1	2	3	4	5	6
20 %	39.5	42.0	44.5	47.0	49.5	52.0	54.5
30 %	38.0	40.5	43.0	45.5	48.0	50.5	53.0
40 %	36.5	39.0	41.5	44.0	46.5	49.0	51.5
50 %	35.0	37.5	40.0	42.5	45.0	47.5	50.0
60 %	33.5	36.0	38.5	41.0	43.5	46.0	48.5
70 %	32.0	34.5	37.0	39.5	42.0	44.5	47.0
80 %	30.5	33.0	35.5	38.0	40.5	43.0	45.5
90 %	29.0	31.5	34.0	36.5	39.0	41.5	44.0
100 %	27.5	30.0	32.5	35.0	37.5	40.0	42.5

Termostaadi tehaseseade on 4.

#### AB-QM DN 25-32 (45-60 °C)

Temp. seade (°C)	QT anduri seade (pööret)						
	0	1	2	3	4	5	6
20 %	49.5	52.0	54.5	57.0	59.5	62.0	64.5
30 %	48.0	50.5	53.0	55.5	58.0	60.5	63.0
40 %	46.5	49.0	51.5	54.0	56.5	59.0	61.5
50 %	45.0	47.5	50.0	52.5	55.0	57.5	60.0
60 %	43.5	46.0	48.5	51.0	53.5	56.0	58.5
70 %	42.0	44.5	47.0	49.5	52.0	54.5	57.0
80 %	40.5	43.0	45.5	48.0	50.5	53.0	55.5
90 %	39.0	41.5	44.0	46.5	49.0	51.5	54.0
100 %	37.5	40.0	42.5	45.0	47.5	50.0	52.5

Termostaadi tehaseseade on 4.

#### AB-QM DN 25-32 (65-85 °C)

Temp. seade (°C)	QT anduri seade (pööret)						
	0	1	2	3	4	5	6
20 %	72.5	75.0	77.5	80.0	84.0	88.0	92.5
30 %	70.0	73.0	75.5	78.0	82.0	86.0	90.5
40 %	67.5	70.5	73.3	76.0	80.0	83.5	87.0
50 %	65.0	68.0	72.0	74.0	77.5	80.5	85.0
60 %	62.5	65.8	69.2	72.5	76.5	79.0	84.0
70 %	60.0	64.5	68.5	71.5	75.5	78.0	83.0
80 %	58.0	63.0	67.0	70.0	74.0	77.0	81.5
90 %	56.5	61.0	65.0	69.0	72.5	76.5	80.5
100 %	55.0	59.0	63.0	67.5	71.5	75.5	79.5

Termostaadi tehaseseade on 4.

## Thermostatic actuator QT / QTL

### LIETUVIŲ K.

#### Surinkimas ①

Įstatykite adapterį ① į termostato angą

#### Konstrukcija ②

Sumontuokite AB-QM ③ ventiliį (žiūrėkite AB-QM instrukciją)

- ① Nustatymo mygtukas
- ② Adapteris
- ③ AB-QM ventilis
- ④ Šildymo vamzdis
- ⑤ Temperatūros jutiklis

AB-QM ventilyje nustatykite norimą dydį (žiūrėkite AB-QM instrukciją)

#### Montavimas ③

QT/QTL montuojamas ant AB-QM rankiniu būdu. Maksimalus leistinas sukimo momentas yra 5 Nm.

#### Jutiklio montavimas ④

AB-QM turi būti sumontuotas ant grįžtamojo vamzdžio. Paprastai jutiklis turi visada būti uždėtas šiltesnėje vietoje nei termostato galvutė.

Vienvamzdės sistemos atveju AB-QM turi būti sumontuotas po ir kaip galima arčiau paskutinio radiatoriaus.

QT montuojamas ant AB-QM rankiniu būdu. Maksimalus leistinas sukimo momentas yra 5 Nm.

Tinkamam šilumos perdavimui iš šilumos tiekimo vamzdžio į termostato elementą labai svarbu panaudoti terminę pastą (pridedama pakuotėje), užtepant ją tarp kontaktuojančių paviršių.

Rekomenduojame izoliuoti jutiklį, jei termostatas montuojamas labai šaltoje vietoje (< 5 °C).

Jutiklį galima montuoti bet kokia kryptimi. Jį galima montuoti aukščiau arba žemiau termostato galvutės.

- ① Jutiklio laikiklis (Sensor holder)
- ② Tvirtinimo elementas (Fastener)
- ③ Terminė pasta (Thermo paste)
- ④ Karšto vandens tiekimas (Hotwater supply)
- ⑤ Geriausias veikimas (Best performance)

#### Nustatymas ⑤

QT/QTL temperatūros nustatymas priklauso nuo AB-QM srauto nustatymo.

Svarbu nustatyti norimą nustatymą AB-QM vožtuve prieš sumontuojant termostatą. Rekomenduojamos AB-QM nustatymo ribos – 30 -70 %.

QT/QTL termostatas nustatomas ties reikiamu dydžiu rankiniu būdu. Kai reikalingas minimalus arba maksimalus dydis, nustačius pasukite QT/QTL nustatymo rankenėlę nežymiai į priešingą pusę, siekiant užtikrinti optimalų termostato veikimą.

Atkreipiame jūsų dėmesį, kad duomenys pateiktose lentelėse yra orientaciniai, ir jie gali keistis, priklausomai nuo sistemos. Naudokite juos tik kaip orientacinius duomenis. Tiksliai temperatūrai nustatyti kontroliniame taške reikia atilkti temperatūros patikrą ir atitinkamai nustatyti jutiklį.

#### AB-QM DN 10-20 (35-50 °C)

Temp. nustatymas (°C)	QT jutiklio nustatymas (pasukimai)						
	0	1	2	3	4	5	6
20 %	38.0	40.5	43.0	45.5	48.0	50.5	53.0
30 %	37.0	39.5	42.0	44.5	47.0	49.5	52.0
40 %	36.0	38.5	41.0	43.5	46.0	48.5	51.0
50 %	35.0	37.5	40.0	42.5	45.0	47.5	50.0
60 %	34.0	36.5	39.0	41.5	44.0	46.5	49.0
70 %	33.0	35.5	38.0	40.5	43.0	45.5	48.0
80 %	32.0	34.5	37.0	39.5	42.0	44.5	47.0
90 %	31.0	33.5	36.0	38.5	41.0	43.5	46.0
100 %	30.0	32.5	35.0	37.5	40.0	42.5	45.0

Termostato nustatymas gamykloje - ties 4 padala.

#### AB-QM DN 10-20 (45-60 °C)

Temp. nustatymas (°C)	QT jutiklio nustatymas (pasukimai)						
	0	1	2	3	4	5	6
20 %	48.0	50.5	53.0	55.5	58.0	60.5	63.0
30 %	47.0	49.5	52.0	54.5	57.0	59.5	62.0
40 %	46.0	48.5	51.0	53.5	56.0	58.5	61.0
50 %	45.0	47.5	50.0	52.5	55.0	57.5	60.0
60 %	44.0	46.5	49.0	51.5	54.0	56.5	59.0
70 %	43.0	45.5	48.0	50.5	53.0	55.5	58.0
80 %	42.0	44.5	47.0	49.5	52.0	54.5	57.0
90 %	41.0	43.5	46.0	48.5	51.0	53.5	56.0
100 %	40.0	42.5	45.0	47.5	50.0	52.5	55.0

Termostato nustatymas gamykloje - ties 4 padala.

#### AB-QM DN 10-20 (65-85 °C)

Temp. nustatymas (°C)	QT jutiklio nustatymas (pasukimai)						
	0	1	2	3	4	5	6
20 %	68.5	71.0	73.5	76.5	80.0	83.5	87.5
30 %	67.0	70.0	72.5	76.0	79.0	82.5	86.5
40 %	66.0	69.0	71.5	75.0	78.5	81.5	85.5
50 %	65.0	68.0	71.0	74.5	77.5	81.0	85.0
60 %	63.5	67.0	70.5	74.0	76.5	80.0	84.0
70 %	62.0	65.5	69.0	72.5	75.5	79.0	83.5
80 %	60.5	64.0	67.5	71.0	74.5	78.0	83.0
90 %	58.5	62.5	66.0	69.5	73.5	77.5	82.0
100 %	57.0	61.0	64.5	68.0	72.5	77.0	81.5

Termostato nustatymas gamykloje - ties 4 padala.

#### AB-QM DN 25-32 (35-50 °C)

Temp. nustatymas (°C)	QT jutiklio nustatymas (pasukimai)						
	0	1	2	3	4	5	6
20 %	39.5	42.0	44.5	47.0	49.5	52.0	54.5
30 %	38.0	40.5	43.0	45.5	48.0	50.5	53.0
40 %	36.5	39.0	41.5	44.0	46.5	49.0	51.5
50 %	35.0	37.5	40.0	42.5	45.0	47.5	50.0
60 %	33.5	36.0	38.5	41.0	43.5	46.0	48.5
70 %	32.0	34.5	37.0	39.5	42.0	44.5	47.0
80 %	30.5	33.0	35.5	38.0	40.5	43.0	45.5
90 %	29.0	31.5	34.0	36.5	39.0	41.5	44.0
100 %	27.5	30.0	32.5	35.0	37.5	40.0	42.5

Termostato nustatymas gamykloje - ties 4 padala.

#### AB-QM DN 25-32 (45-60 °C)

Temp. nustatymas (°C)	QT jutiklio nustatymas (pasukimai)						
	0	1	2	3	4	5	6
20 %	49.5	52.0	54.5	57.0	59.5	62.0	64.5
30 %	48.0	50.5	53.0	55.5	58.0	60.5	63.0
40 %	46.5	49.0	51.5	54.0	56.5	59.0	61.5
50 %	45.0	47.5	50.0	52.5	55.0	57.5	60.0
60 %	43.5	46.0	48.5	51.0	53.5	56.0	58.5
70 %	42.0	44.5	47.0	49.5	52.0	54.5	57.0
80 %	40.5	43.0	45.5	48.0	50.5	53.0	55.5
90 %	39.0	41.5	44.0	46.5	49.0	51.5	54.0
100 %	37.5	40.0	42.5	45.0	47.5	50.0	52.5

Termostato nustatymas gamykloje - ties 4 padala.

#### AB-QM DN 25-32 (65-85 °C)

Temp. nustatymas (°C)	QT jutiklio nustatymas (pasukimai)						
	0	1	2	3	4	5	6
20 %	72.5	75.0	77.5	80.0	84.0	88.0	92.5
30 %	70.0	73.0	75.5	78.0	82.0	86.0	90.5
40 %	67.5	70.5	73.3	76.0	80.0	83.5	87.0
50 %	65.0	68.0	72.0	74.0	77.5	80.5	85.0
60 %	62.5	65.8	69.2	72.5	76.5	79.0	84.0
70 %	60.0	64.5	68.5	71.5	75.5	78.0	83.0
80 %	58.0	63.0	67.0	70.0	74.0	77.0	81.5
90 %	56.5	61.0	65.0	69.0	72.5	76.5	80.5
100 %	55.0	59.0	63.0	67.5	71.5	75.5	79.5

Termostato nustatymas gamykloje - ties 4 padala.

## Thermostatic actuator QT / QTL

### LATVISKI

#### Komplektēšana ①

Ievietojiet ① adapteri termostatā

#### Sastāvdaļas ②

Uzstādiet AB-QM vārstu ③ (skat. AB-QM instrukciju)

- ① Ieregulēšanas gredzens
- ② Adapters
- ③ AB-QM vārsts
- ④ Caurule
- ⑤ Temperatūras sensors

Ieregulējiet vajadzīgo iestatījumu AB-QM vārstam (skat. AB-QM instrukciju)

#### Montāža ③

QT/QTL nepieciešams uzstādīt uz AB-QM ar roku. Maksimālais pieļaujamais griezes moments ir 5 Nm.

#### Sensora montāža ④

AB-QM ir jāmontē uz atgaitas caurules. Vispārīgā gadījumā sensors vie Nmēr ir jānovieto vietā, kura ir siltāka nekā termostata galva.

Vienas caurules sistēmā AB-QM ir jāmontē aiz pēdējā radiatora un pēc iespējas tuvāk tam.

QT nepieciešams uzstādīt uz AB-QM ar roku. Maksimālais pieļaujamais griezes moments ir 5 Nm.

Lai nodrošinātu siltuma pārvadi starp apkures cauruli un termostata sensoru, ir ļoti svarīgi uzklāt termosmēri (ir komplektā) uz kontakta virsmas.

Ieteicams izolēt sensoru, ja termostats ir uzstādīts ļoti aukstā vietā (< 5 °C).

Pašu sensoru var uzstādīt jebkurā virzienā. To var uzstādīt gan virs gan zem sensora galvas.

- ① Sensora kabata (Sensor holder)
- ② Savilce (Fastener)
- ③ Termo pasta (Thermo paste)
- ④ Turpgaita (Hotwater supply)
- ⑤ Labākā darbība (Best performance)

#### Ieregulēšana ⑤

QT/QTL temperatūras uzstādījums ir atkarīgs no AB-QM plūsmas uzstādījuma.

Nepieciešams ieregulēt AB-QM vārstu uz vēlamu plūsmu pirms termostata montāžas. Ieteicamais plūsmas diapazons AB-QM vārstam ir no 30 līdz 70 %.

QT/QTL termostats tiek iestatīts uz vēlamu vērtību ar roku. Kad nepieciešams minimālais vai maksimālais iestatījums, QT/QTL ieregulēšanas gredzenu nepieciešams nedaudz pagriezt pretējā virzienā, lai nodrošinātu optimālu termostata darbību.

**Nemiet vērā, ka pievienotās tabulas ir informatīvas un var atšķirties atkarībā no pielietojuma. Tās var izmantot tikai kā vadlīniju. Precīzai temperatūras verificācijai temperatūru ir jāmēra atskaites punktā un sensors jāiestata atbilstoši.**

#### AB-QM DN 10-20 (35-50 °C)

Temp. (°C)	QT Sensora stāvoklis (apgriezieni)						
	0	1	2	3	4	5	6
20 %	38.0	40.5	43.0	45.5	48.0	50.5	53.0
30 %	37.0	39.5	42.0	44.5	47.0	49.5	52.0
40 %	36.0	38.5	41.0	43.5	46.0	48.5	51.0
50 %	35.0	37.5	40.0	42.5	45.0	47.5	50.0
60 %	34.0	36.5	39.0	41.5	44.0	46.5	49.0
70 %	33.0	35.5	38.0	40.5	43.0	45.5	48.0
80 %	32.0	34.5	37.0	39.5	42.0	44.5	47.0
90 %	31.0	33.5	36.0	38.5	41.0	43.5	46.0
100 %	30.0	32.5	35.0	37.5	40.0	42.5	45.0

Termostata rūpnīcas iestatījums ir 4.

#### AB-QM DN 10-20 (45-60 °C)

Temp. (°C)	QT Sensora stāvoklis (apgriezieni)						
	0	1	2	3	4	5	6
20 %	48.0	50.5	53.0	55.5	58.0	60.5	63.0
30 %	47.0	49.5	52.0	54.5	57.0	59.5	62.0
40 %	46.0	48.5	51.0	53.5	56.0	58.5	61.0
50 %	45.0	47.5	50.0	52.5	55.0	57.5	60.0
60 %	44.0	46.5	49.0	51.5	54.0	56.5	59.0
70 %	43.0	45.5	48.0	50.5	53.0	55.5	58.0
80 %	42.0	44.5	47.0	49.5	52.0	54.5	57.0
90 %	41.0	43.5	46.0	48.5	51.0	53.5	56.0
100 %	40.0	42.5	45.0	47.5	50.0	52.5	55.0

Termostata rūpnīcas iestatījums ir 4.

#### AB-QM DN 10-20 (65-85 °C)

Temp. (°C)	QT Sensora stāvoklis (apgriezieni)						
	0	1	2	3	4	5	6
20 %	68.5	71.0	73.5	76.5	80.0	83.5	87.5
30 %	67.0	70.0	72.5	76.0	79.0	82.5	86.5
40 %	66.0	69.0	71.5	75.0	78.5	81.5	85.5
50 %	65.0	68.0	71.0	74.5	77.5	81.0	85.0
60 %	63.5	67.0	70.5	74.0	76.5	80.0	84.0
70 %	62.0	65.5	69.0	72.5	75.5	79.0	83.5
80 %	60.5	64.0	67.5	71.0	74.5	78.0	83.0
90 %	58.5	62.5	66.0	69.5	73.5	77.5	82.0
100 %	57.0	61.0	64.5	68.0	72.5	77.0	81.5

Termostata rūpnīcas iestatījums ir 4.

#### AB-QM DN 25-32 (35-50 °C)

Temp. (°C)	QT Sensora stāvoklis (apgriezieni)						
	0	1	2	3	4	5	6
20 %	39.5	42.0	44.5	47.0	49.5	52.0	54.5
30 %	38.0	40.5	43.0	45.5	48.0	50.5	53.0
40 %	36.5	39.0	41.5	44.0	46.5	49.0	51.5
50 %	35.0	37.5	40.0	42.5	45.0	47.5	50.0
60 %	33.5	36.0	38.5	41.0	43.5	46.0	48.5
70 %	32.0	34.5	37.0	39.5	42.0	44.5	47.0
80 %	30.5	33.0	35.5	38.0	40.5	43.0	45.5
90 %	29.0	31.5	34.0	36.5	39.0	41.5	44.0
100 %	27.5	30.0	32.5	35.0	37.5	40.0	42.5

Termostata rūpnīcas iestatījums ir 4.

#### AB-QM DN 25-32 (45-60 °C)

Temp. (°C)	QT Sensora stāvoklis (apgriezieni)						
	0	1	2	3	4	5	6
20 %	49.5	52.0	54.5	57.0	59.5	62.0	64.5
30 %	48.0	50.5	53.0	55.5	58.0	60.5	63.0
40 %	46.5	49.0	51.5	54.0	56.5	59.0	61.5
50 %	45.0	47.5	50.0	52.5	55.0	57.5	60.0
60 %	43.5	46.0	48.5	51.0	53.5	56.0	58.5
70 %	42.0	44.5	47.0	49.5	52.0	54.5	57.0
80 %	40.5	43.0	45.5	48.0	50.5	53.0	55.5
90 %	39.0	41.5	44.0	46.5	49.0	51.5	54.0
100 %	37.5	40.0	42.5	45.0	47.5	50.0	52.5

Termostata rūpnīcas iestatījums ir 4.

#### AB-QM DN 25-32 (65-85 °C)

Temp. (°C)	QT Sensora stāvoklis (apgriezieni)						
	0	1	2	3	4	5	6
20 %	72.5	75.0	77.5	80.0	84.0	88.0	92.5
30 %	70.0	73.0	75.5	78.0	82.0	86.0	90.5
40 %	67.5	70.5	73.3	76.0	80.0	83.5	87.0
50 %	65.0	68.0	72.0	74.0	77.5	80.5	85.0
60 %	62.5	65.8	69.2	72.5	76.5	79.0	84.0
70 %	60.0	64.5	68.5	71.5	75.5	78.0	83.0
80 %	58.0	63.0	67.0	70.0	74.0	77.0	81.5
90 %	56.5	61.0	65.0	69.0	72.5	76.5	80.5
100 %	55.0	59.0	63.0	67.5	71.5	75.5	79.5

Termostata rūpnīcas iestatījums ir 4.

#### ИМПОРТЕР:

UA: ТОВ з ІІ «Данфосс ТОВ», вул. Вікентія Хвойки, 15/15/6, м. Київ, 04080, Україна

#### Danfoss A/S

Climate Solutions • danfoss.com • +45 7488 2222

All information, including, but not limited to information on selection of product, its application or use, product design, weight, dimensions, capacity or any other technical data in product manuals, catalogues descriptions, advertisements, etc. and whether made available in writing, orally, electronically, online or via download, shall be considered informative, and is only binding if and to the extent, explicit reference is made in a quotation or order confirmation. Danfoss cannot accept any responsibility for possible errors in catalogues, brochures, videos and other material. Danfoss reserves the right to alter its products without notice. This also applies to products ordered but not delivered provided that such alterations can be made without changes to form, fit or function of the product.

All trademarks in this material are property of Danfoss A/S or Danfoss group companies. Danfoss and the Danfoss logo are trademarks of Danfoss A/S. All rights reserved.