

ENGINEERING  
TOMORROW

*Danfoss*

Application Guide

# Designing hydronic floor heating

Get the optimum results

**7** applications

to help you design  
and install Danfoss  
floor heating systems.



**ЮГОВ - Проект**

інженерно-виробниче підприємство

Офіційний дистриб'ютор  
Danfoss в Україні



ugov.ua

heating.danfoss.com



# THE RIGHT PRODUCTS FOR YOUR APPLICATION

Choosing the right products not only depends on the application. Once you have identified the product groups relevant for your application, simply go to the Product Guide brochure to narrow down the choice to specific product codes.

This application guide:

- Recommends specific product groups for different applications
- Recommends which pipe layout pattern to use in different situations
- Shows the benefits and impact of using cement and liquid screed

# Application guides for manifolds and controls

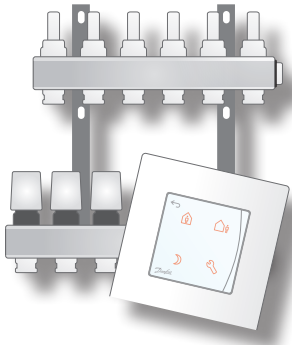

- 05 | Floor heating system with individual room control  
**Low temperature**
- 06 | Floor heating system with individual room control  
**High temperature**
- 07 | Floor heating system with individual room control  
**High and low temperature**
- 08 | Mixed system with individual room control  
**High temperature**
- 09 | Floor heating system with reference room control  
**Low temperature**
- 10 | Floor heating system with individual room control  
**Low temperature and cooling in 2-pipe system**
- 11 | Floor heating system with hybrid Air/Water heat pump with integrated condensing boiler (example: Itho Cool Cube). Reference room control  
**Low temperature**
- 12 | Floor heating system with automatic changeover for cooling based on supply temperature. Individual room control  
**Low temperature**
- 13 | **Mixed system**  
With self-acting room control
- 14 | Floor heating system with individual room control  
**Low temperature and cooling in 3/4-pipe system**
- 15 | Floor heating 3-pipe system with cooling controlled via motorized valve. Reference room control  
**High and low temperature**
- 16 | Floor heating 4-pipe system with cooling controlled via 6-port valve, automatic changeover. Reference room control  
**High and low temperature**

## How to design effective pipe layout



- 20 | Meander pattern vs. snail pattern  
**Benefits**
- 21 | Small windows vs. large windows  
**Pipe distance**
- 22 | Bathroom and kitchen  
**Laying patterns and distance**
- 23 | Large rooms  
**Laying patterns and distance**

## Choosing the right floor screed

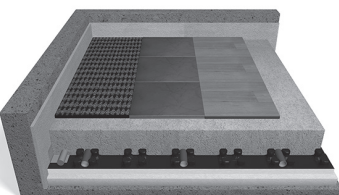

- 25 | Liquid screed vs. cement screed  
**Benefits and impact**

# APPLICATION SYMBOLS

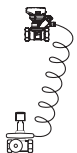

Balancing valves

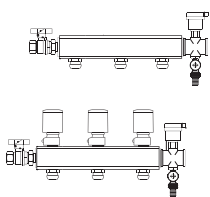

Manifold with control valves for actuators

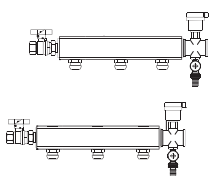

Manifold without control valves for actuators

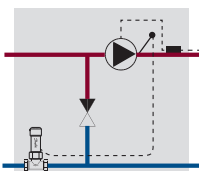

Mixing shunt

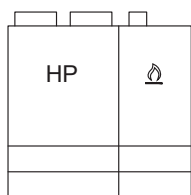

Hybrid Air/Water heat pump with integrated condensing boiler

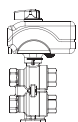

6-port valve



Room thermostat wired



3-way valve



2-way valve



RA-HC with actuator TWA



FHV self-acting thermostatic valve

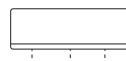

Master controller



ECL weather compensator



ESM-11 pipe sensor for supply pipe for automatic change over between cooling and heating



Reference thermostat



Dew point sensor



Room thermostat generic

# Floor heating system with individual room control

## Low temperature

### Where to use:



1 and 2 family houses



Multi family houses

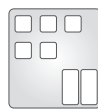

Light commercial buildings



### Advantages:

- Individual room comfort and energy savings achieved by room thermostats
- Energy savings on heat production and pump energy with connection box relays
- Ensure correct flow to heating system on apartment level with balancing valves and manifold flow setting

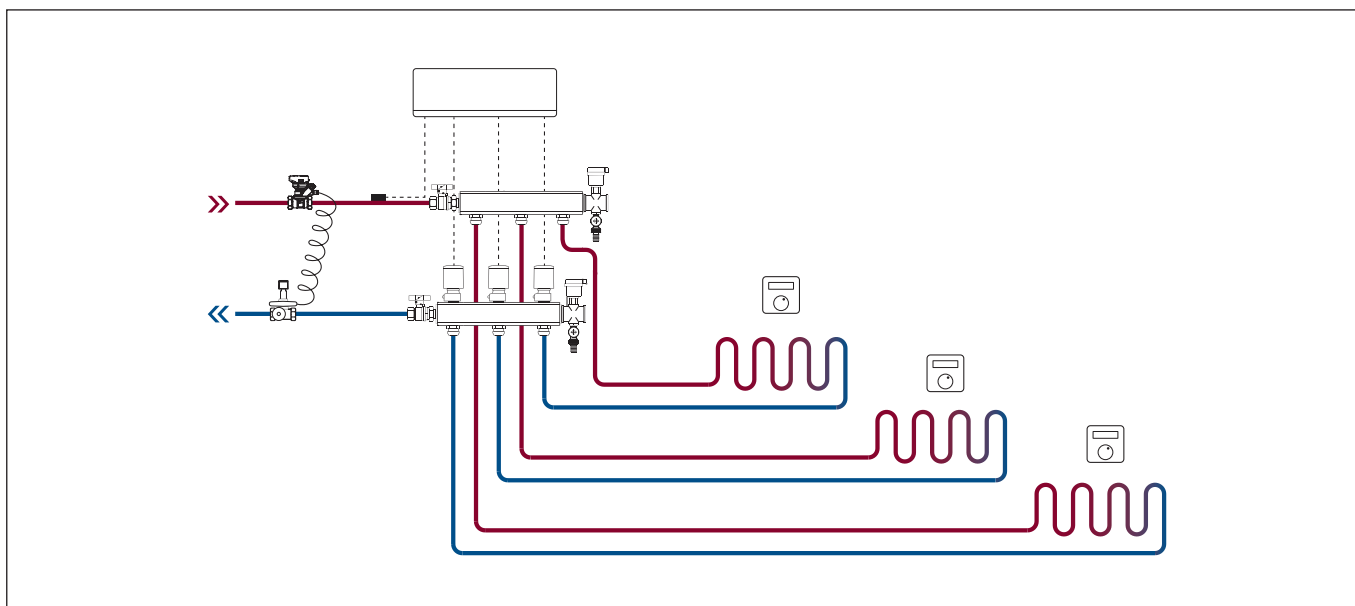

### Components suitable for application:

<b>Controls</b>	Danfoss Link™	Danfoss Icon™ 24V / Wireless	Danfoss Icon™ 230V	FH-Wx	BacisPlus <sup>2</sup>	FHV
	✓	✓	(✓)*	✓	(✓)*	
<b>Manifolds</b>	FHF-F	FHF	FH-ME	FHF-B	SSM-F	SSM
	✓	✓	✓	✓	✓	✓
<b>Balancing valve</b>	AB-PM	ASV-PV + ASV-BD				
	✓	✓				

### Complementary product suitable for application:

- Mixing shunts are not needed in low supply temperature applications

\* Danfoss Icon™ 230 V and BasicPlus<sup>2</sup> can be combined with connection box to achieve energy savings on heat production and pump energy with relays

# Floor heating system with individual room control

## High temperature

**Where to use:**

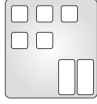
-   
 1 and 2 family houses  
 ✓
-   
 Multi family houses  
 ✓
-   
 Light commercial buildings  
 ✓

- Advantages:**
- Individual room comfort and energy savings achieved by room thermostats
  - Energy savings on heat production and pump energy with connection box relays
  - Ensure correct flow to heating system on apartment level with balancing valves and manifold flow setting

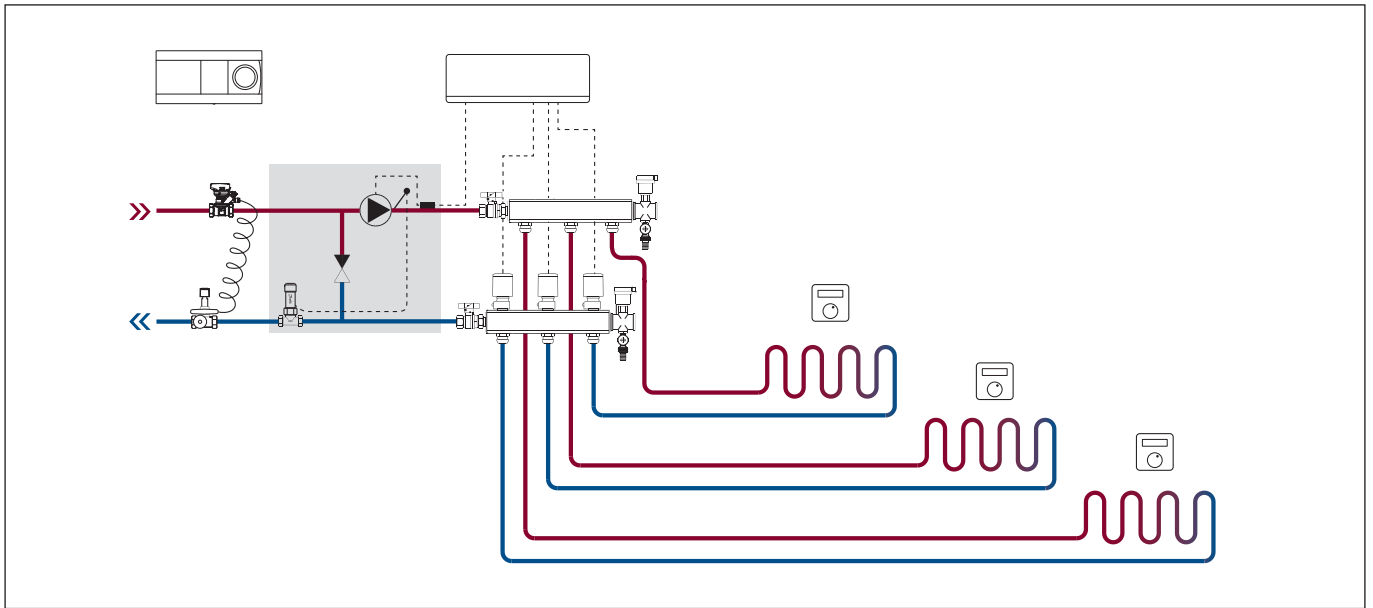

### Components suitable for application:

<b>Controls</b>	Danfoss Link™	Danfoss Icon™ 24V / Wireless	Danfoss Icon™ 230V	FH-Wx	BacisPlus <sup>2</sup>	FHV
	✓	✓	(✓)*	✓	(✓)*	
<b>Manifolds</b>	FHF-F	FHF	FH-ME	FHF-B	SSM-F	SSM
	✓	✓	✓	✓	✓	✓
<b>Balancing valve</b>	AB-PM	ASV-PV + ASV-BD				
	✓	✓				

### Complementary product suitable for application:

- Mixing shunts to be used in applications with high supply temperatures
- Use ECL to allow for weather compensated supply temperatures.

\* Danfoss Icon™ 230 V and BasicPlus<sup>2</sup> can be combined with connection box to achieve energy savings on heat production and pump energy with relays

# Floor heating system with individual room control

## High and low temperature

### Where to use:



1 and 2 family houses



Multi family houses

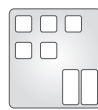

Light commercial buildings



### Advantages:

- Fixed or based on demand supply temperature control
- Low (25 °C to 65 °C) and High (30 °C to 70 °C) temperature modes
- Supply temperature controlling is based on super fast PWM pulsing (patented)
- Auto balancing function by Danfoss Icon™

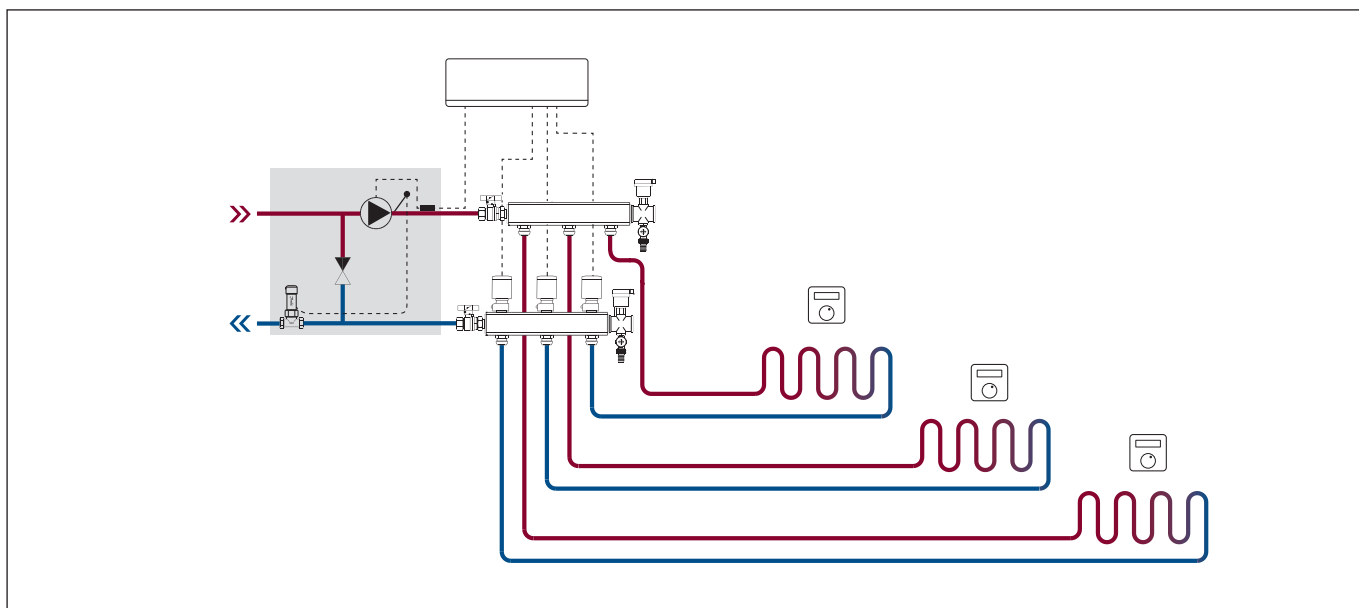

### Components suitable for application:

<b>Controls</b>	Danfoss Link™	Danfoss Icon™ 24V / Wireless	Danfoss Icon™ 230V	FH-Wx	BacisPlus <sup>2</sup>	FHV
		✓				
<b>Manifolds</b>	FHF-F	FHF	FH-ME	FHF-B	SSM-F	SSM
	✓	✓	✓	✓	✓	✓
<b>Balancing valve</b>	AB-PM	ASV-PV + ASV-BD				
	✓	✓				



### Complementary product suitable for application:

- Danfoss Icon™ Expansion module and surface temperature sensor are required for this application

# Mixed system with individual room control

## High temperature

**Where to use:**

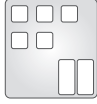
-   
 1 and 2 family houses  
 ✓
-   
 Multi family houses  
 ✓
-   
 Light commercial buildings  
 ✓

- Advantages:**
- Individual room comfort and energy savings achieved by room thermostats
  - Energy savings on heat production and pump energy with connection box relays
  - Ensure correct flow to heating system on apartment level with balancing valves and manifold flow setting

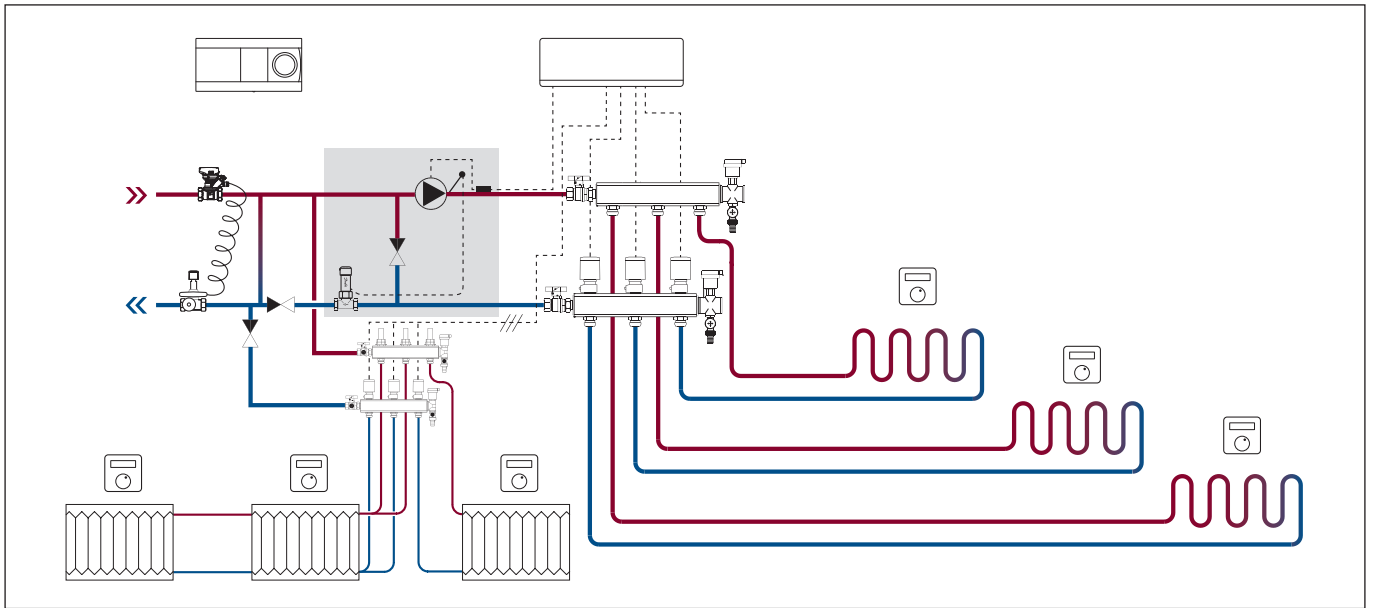

### Components suitable for application:

Controls	Danfoss Link™	Danfoss Icon™ 24V / Wireless	Danfoss Icon™ 230V	FH-Wx	BacisPlus²	FHV
	✓	✓	(✓)*	✓	(✓)*	
Manifolds	FHF-F	FHF	FH-ME	FHF-B	SSM-F	SSM
	✓	✓	✓	✓	✓	✓
Balancing valve	AB-PM	ASV-PV + ASV-BD				
	✓	✓				

### Complementary product suitable for application:

- Mixing shunts to be used in mixed systems where there is a need to differentiate the supply temperature in part of the system e.g. radiator system with high supply temperature and floor heating with low temperature.
- Use ECL to allow for weather compensated supply temperatures.

\* Danfoss Icon™ 230 V and BasicPlus² can be combined with connection box to achieve energy savings on heat production and pump energy with relays

# Floor heating system with reference room control

## Low temperature

**Where to use:**

-   
 1 and 2 family houses  
 ✓
-   
 Multi family houses  
 ✓
-   
 Light commercial buildings  
 ✓

**Advantages:**

- Ensure correct flow to heating system on apartment level with balancing valves and manifold flow setting

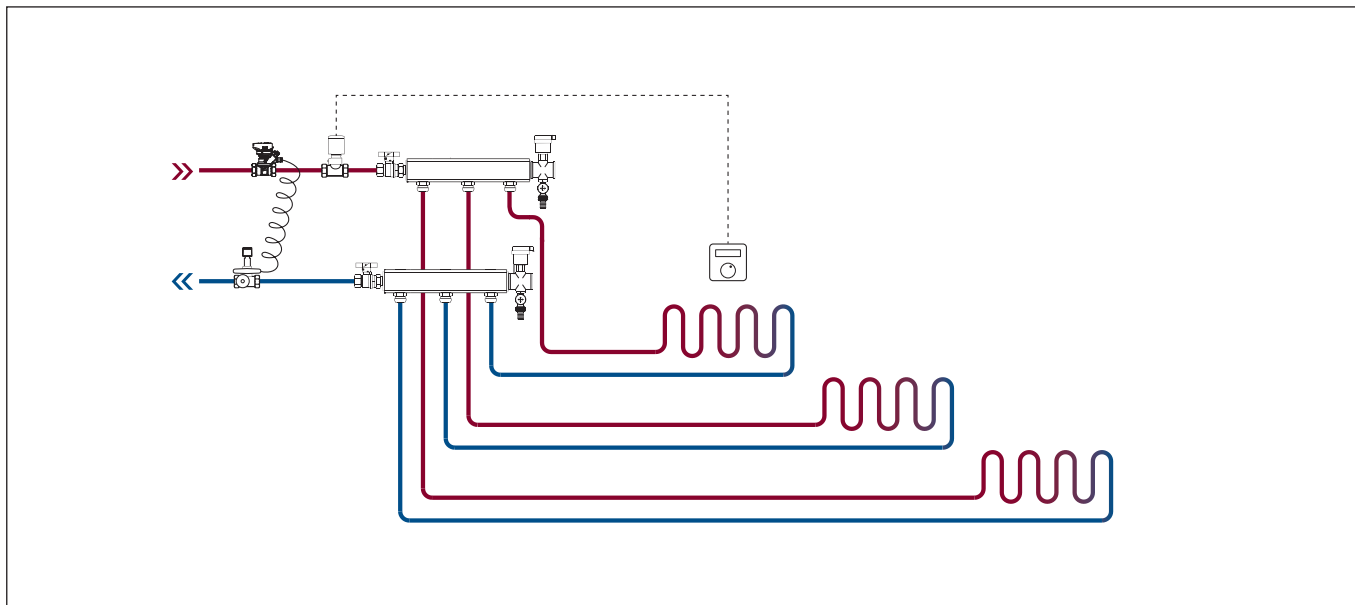

### Components suitable for application:

<b>Controls</b>	Danfoss Link™	Danfoss Icon™ 24V / Wireless	Danfoss Icon™ 230V	FH-Wx	BacisPlus <sup>2</sup>	FHV
	✓	✓	(✓)*	✓	(✓)*	
<b>Manifolds</b>	FHF-F	FHF	FH-ME	FHF-B	SSM-F	SSM
	✓	✓	✓	✓	✓	✓
<b>Balancing valve</b>	AB-PM	ASV-PV + ASV-BD				
	✓	✓				

### Complementary product suitable for application:

- Use manifolds FHF, FHF-F, SSM and SSM-F for easier flow setting
- Rough pre-setting with Allen key

\* Danfoss Icon™ 230 V and BasicPlus<sup>2</sup> can be combined with connection box to achieve energy savings on heat production and pump energy with relays

# Floor heating system with individual room control

## Low temperature and cooling in 2-pipe system

**Where to use:**

-   
 1 and 2 family houses  
 ✓
-   
 Multi family houses  
 ✓
-   
 Light commercial buildings  
 ✓

- Advantages:**
- Individual room comfort and energy savings achieved by room thermostats
  - Energy savings on heat production and pump energy with connection box relays
  - Ensure correct flow to heating system on apartment level with balancing valves and manifold flow setting
  - Use floor heating system for passive cooling

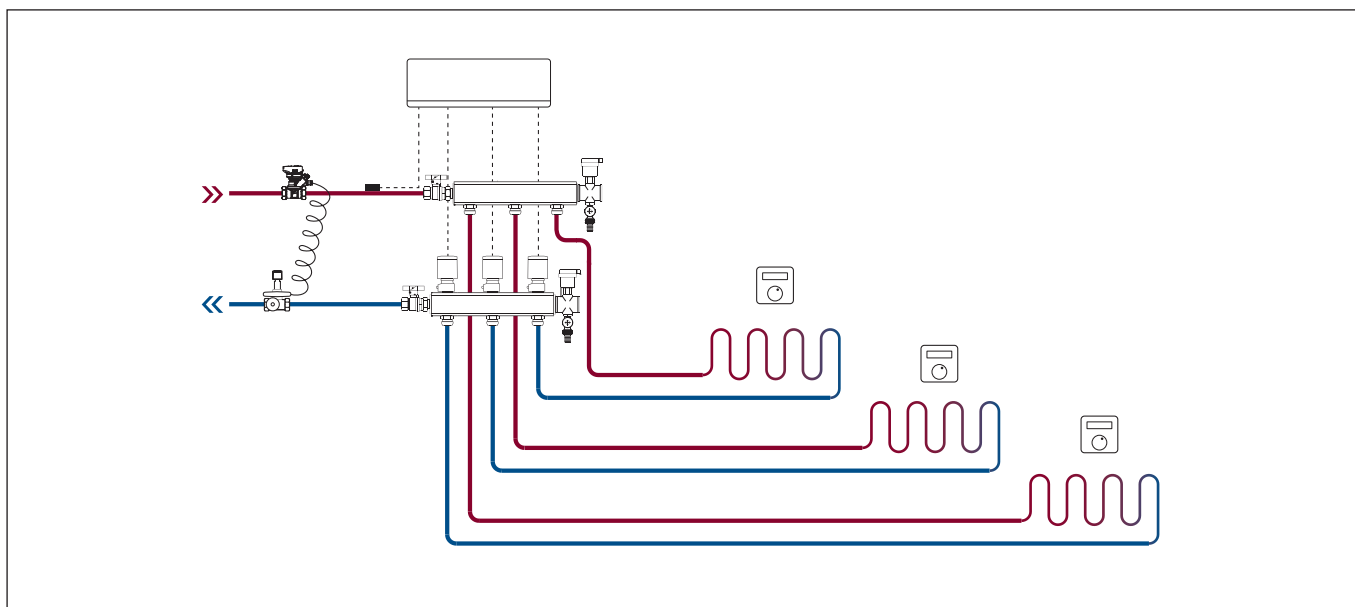

### Components suitable for application:

Controls	Danfoss Link™	Danfoss Icon™ 24V / Wireless	Danfoss Icon™ 230V	FH-Wx	BacisPlus <sup>2</sup>	FHV
	✓	✓	(✓)*	✓	(✓)*	
Manifolds	FHF-F	FHF	FH-ME	FHF-B	SSM-F	SSM
	✓	✓	✓	✓		
Balancing valve	AB-PM	ASV-PV + ASV-BD				
	✓	✓				

### Complementary product suitable for application:

- ESM-11 pipe sensor for automatic change over between cooling and heating based on supply pipe temperature (Danfoss Icon™ 24V Wireless only)
- Remote controller for configuration of system Danfoss Icon™ 230V
- To use dew point sensor a separate 24V power supply is required (Danfoss Icon™ 24V Wireless only)

\* Manual change over between cooling and heating

# Floor heating system with hybrid Air/Water heat pump with integrated condensing boiler (example: Itho Cool Cube). Reference room control

## Low temperature

**Where to use:**

-   
 1 and 2 family houses  
 ✓
-   
 Multi family houses  
 ✓
-   
 Light commercial buildings  
 ✓

- Advantages:**
- Automatically changes to the relevant heat / cooling source
  - Energy saving by setting a neutral time period
  - Auto balancing function by Danfoss Icon™

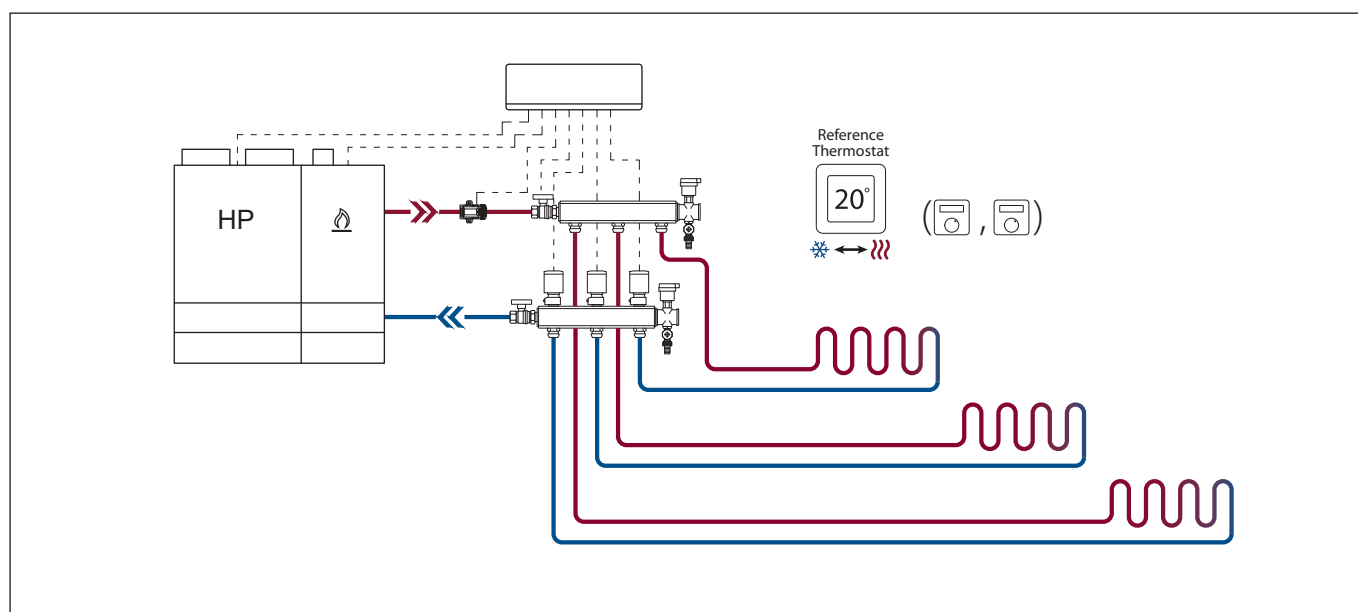

### Components suitable for application:

<b>Controls</b>	Danfoss Link™	Danfoss Icon™ 24V / Wireless	Danfoss Icon™ 230V	FH-Wx	BacisPlus <sup>2</sup>	FHV
		✓				
<b>Manifolds</b>	FHF-F	FHF	FH-ME	FHF-B	SSM-F	SSM
	✓	✓	✓	✓	✓	✓
<b>Balancing valve</b>	AB-PM	ASV-PV + ASV-BD				
	✓	✓				

### Complementary product suitable for application:

- Cool Cube is required for this application
- Danfoss Icon Expansion module
- Dew point sensor

# Floor heating system with automatic changeover for cooling based on supply temperature.

## Individual room control

### Low temperature

**Where to use:**

-  1 and 2 family houses ✓
-  Multi family houses ✓
-  Light commercial buildings ✓

- Advantages:**
- Fixed or based on demand supply temperature control
  - Automatic changing to heating or cooling based on demand
  - Global away relay on expansion module can be used as remote control
  - Auto balancing function by Danfoss Icon™

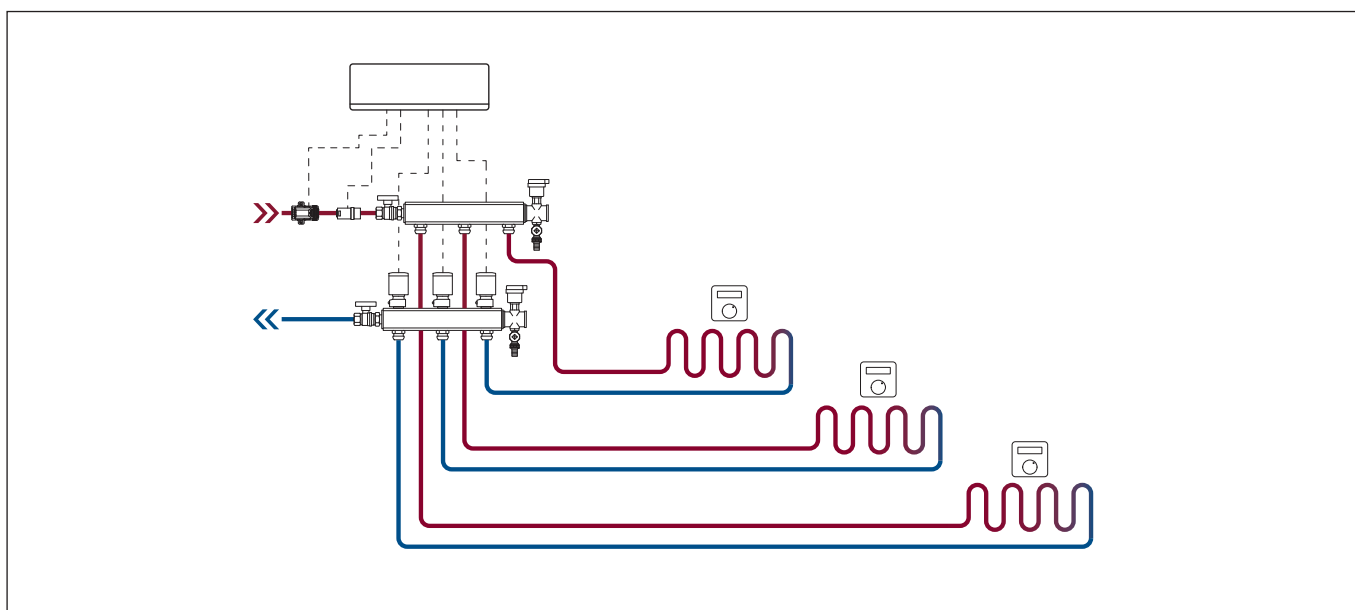

#### Components suitable for application:



Controls	Danfoss Link™	Danfoss Icon™ 24V / Wireless	Danfoss Icon™ 230V	FH-Wx	BacisPlus <sup>2</sup>	FHV
		✓				
Manifolds	FHF-F	FHF	FH-ME	FHF-B	SSM-F	SSM
	✓	✓	✓	✓	✓	✓
Balancing valve	AB-PM	ASV-PV + ASV-BD				
	✓	✓				

#### Complementary product suitable for application:

- Danfoss Icon™ Expansion module, dew point sensor and surface temperature sensor are required for Danfoss Icon™ 24V/Wireless

# Mixed system

## With self-acting room control

**Where to use:**  1 and 2 family houses ✓  Multi family houses ✓

**Advantages:** • Individual room comfort and energy savings achieved by room thermostats

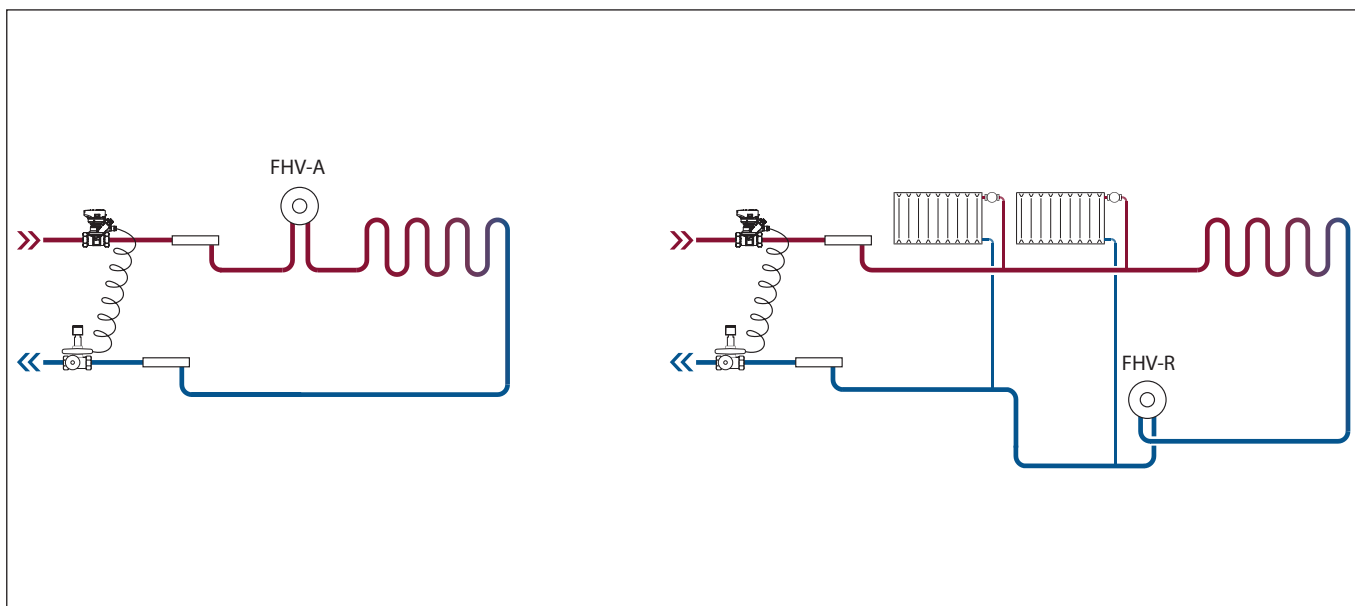

### Components suitable for application:

<b>Controls</b>	Danfoss Link™	Danfoss Icon™ 24V / Wireless	Danfoss Icon™ 230V	FH-Wx	BacisPlus <sup>2</sup>	FHV ✓
<b>Manifolds</b>	FHF-F	FHF	FH-ME	FHF-B ✓	SSM-F	SSM
<b>Balancing valve</b>	AB-PM ✓	ASV-PV + ASV-BD ✓				

### Complementary product suitable for application:



• In case of multi family houses, balancing valve AB-QM should be used

\* Danfoss Icon™ 230 V and BacisPlus<sup>2</sup> can be combined with connection box to achieve energy savings on heat production and pump energy with relays

# Floor heating system with individual room control

## Low temperature and cooling in 3/4-pipe system

**Where to use:**

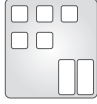
-   
 1 and 2 family houses  
 ✓
-   
 Multi family houses  
 ✓
-   
 Light commercial buildings  
 ✓

- Advantages:**
- Individual room comfort and energy savings achieved by room thermostats
  - Energy savings on heat production and pump energy with connection box relays
  - Ensure correct flow to heating system on apartment level with balancing valves and manifold flow setting
  - Use floor heating system for passive cooling

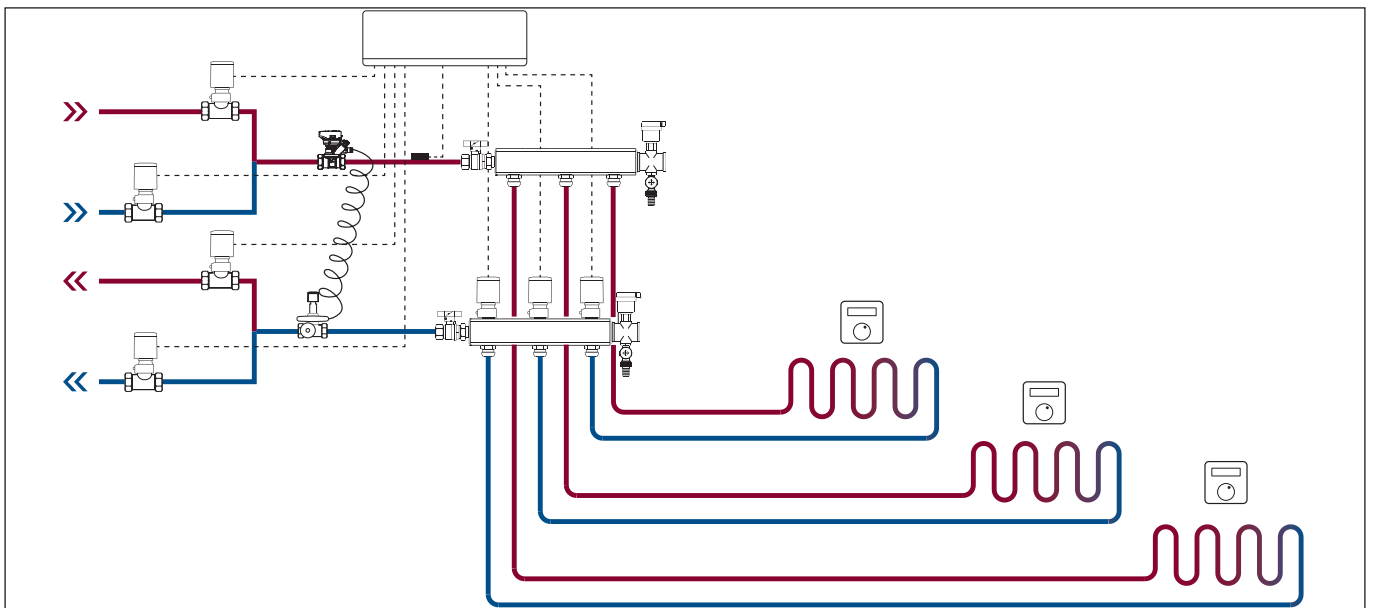

### Components suitable for application:

	Danfoss Link™	Danfoss Icon™ 24V / Wireless	Danfoss Icon™ 230V	FH-Wx	BacisPlus²	FHV
<b>Controls</b>	✓	✓	(✓)*	✓	(✓)*	
<b>Manifolds</b>	FHF-F ✓	FHF ✓	FH-ME ✓	FHF-B ✓	SSM-F	SSM
<b>Balancing valve</b>	AB-PM ✓	ASV-PV + ASV-BD ✓				

### Complementary product suitable for application:

- Remote controller CF-RC for configuration of system
- Dew point sensor CF-DS

\* Only if differential pressure in the system is <1 bar. If differential pressure is higher please contact Danfoss.

# Floor heating 3-pipe system with cooling controlled via motorized valve. Reference room control

## High and low temperature

**Where to use:**

-   
 1 and 2 family houses  
 ✓
-   
 Multi family houses  
 ✓
-   
 Light commercial buildings  
 ✓

- Advantages:**
- Global away relay on expansion module can be used as remote control
  - Automatic changing to heating or cooling ordered via reference thermostat
  - Energy saving by setting a neutral time period
  - Auto balancing function by Danfoss Icon™

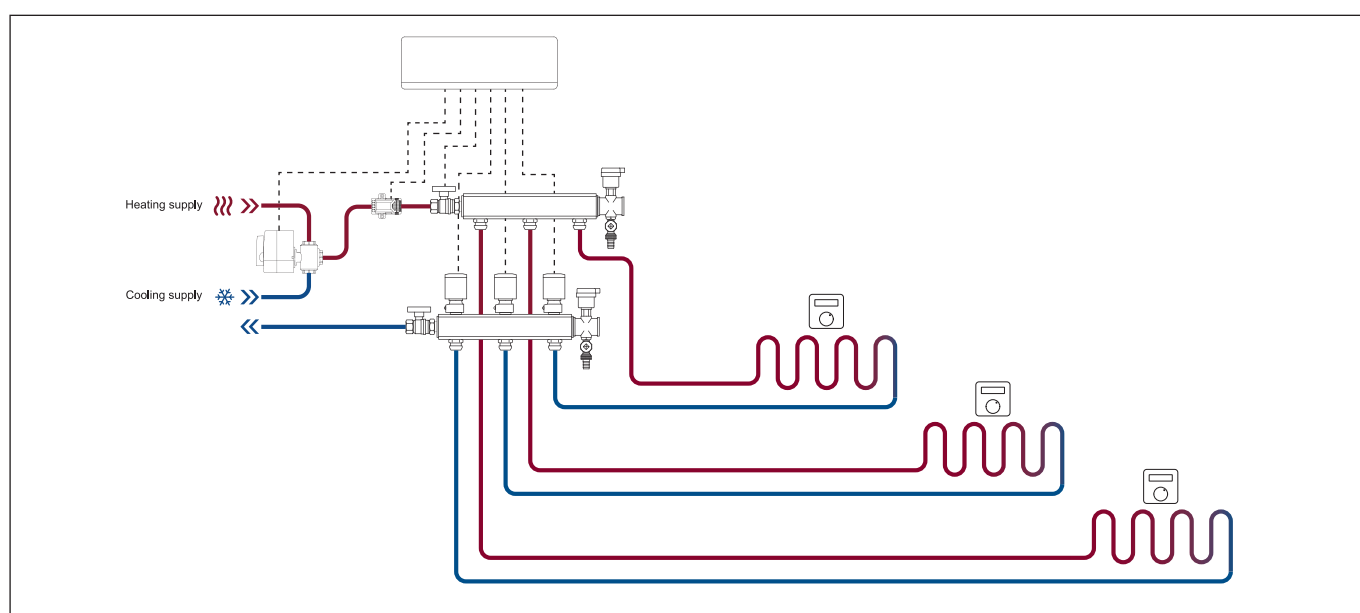

### Components suitable for application:



<b>Controls</b>	Danfoss Link™	Danfoss Icon™ 24V / Wireless	Danfoss Icon™ 230V	FH-Wx	BacisPlus <sup>2</sup>	FHV
		✓				
<b>Manifolds</b>	FHF-F	FHF	FH-ME	FHF-B	SSM-F	SSM
	✓	✓	✓	✓	✓	✓
<b>Balancing valve</b>	AB-PM	ASV-PV + ASV-BD				
	✓	✓				

### Complementary product suitable for application:

- Danfoss Icon™ Expansion module
- Dew point sensor
- 3-way valve (AMZ-113)

# Floor heating 4-pipe system with cooling controlled via 6-port valve, automatic changeover. Reference room control **High** and **Low temperature**

**Where to use:**

-   
 1 and 2 family houses  
 ✓
-   
 Multi family houses  
 ✓
-   
 Light commercial buildings  
 ✓

- Advantages:**
- Global away relay on expansion module can be used as remote control
  - Automatic changing to heating or cooling ordered via reference thermostat
  - Energy saving by setting a neutral time period
  - Automatic shut-off function

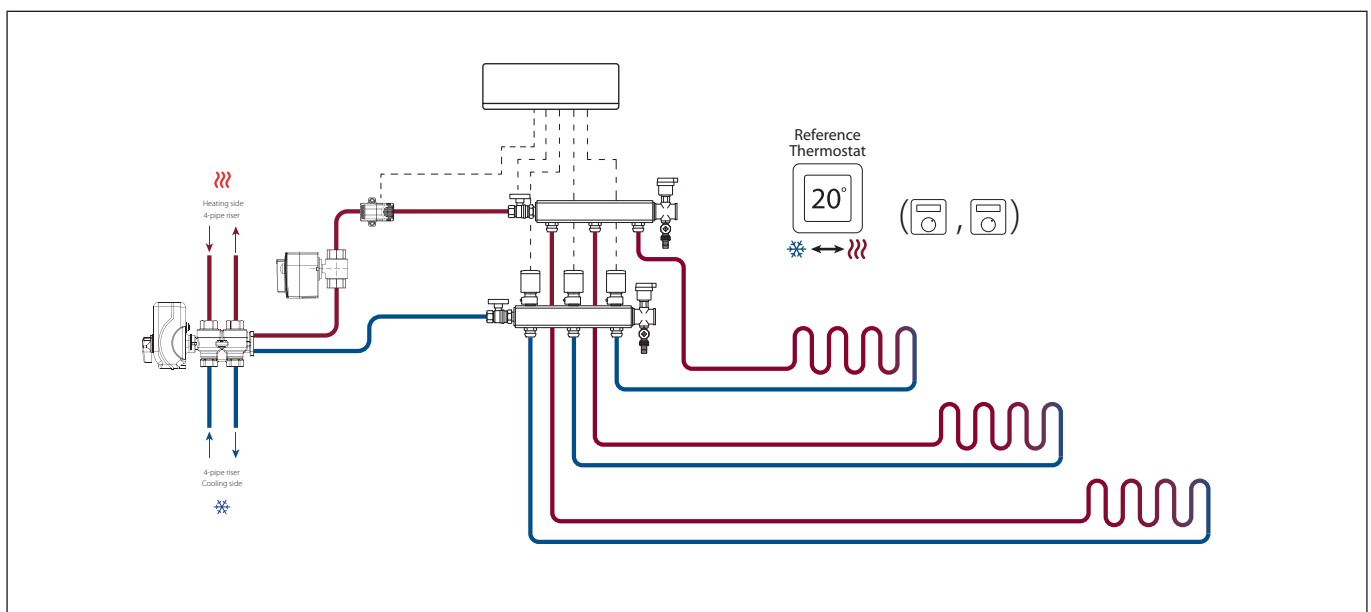

## Components suitable for application:

<b>Controls</b>	Danfoss Link™	Danfoss Icon™ 24V / Wireless	Danfoss Icon™ 230V	FH-Wx	BacisPlus <sup>2</sup>	FHV
		✓				
<b>Manifolds</b>	FHF-F	FHF	FH-ME	FHF-B	SSM-F	SSM
	✓	✓	✓	✓	✓	✓
<b>Balancing valve</b>	AB-PM	ASV-PV + ASV-BD				
	✓	✓				

## Complementary product suitable for application:

- Danfoss Icon Expansion module
- Dew point sensor
- 6-port valve (003Z3155)
- 2-way valve (AMZ-112)



# Easier application specification Online

Our online QuickPlanner dimensioning program enables you to calculate the correct pre-setting values in just minutes. Go online and have the following information ready:

- Room sizes
- Heat requirement (W/m<sup>2</sup>)
- Supply temperature
- Desired room temperature
- Floor type



# HOW TO DESIGN **EFFECTIVE PIPE LAYOUT**

Application guidelines for heating circuit layout.

The application guidelines provide you with basic application ideas and recommendations on how to design effective layout patterns for different rooms.

# Meander pattern vs. snail pattern

## Benefits

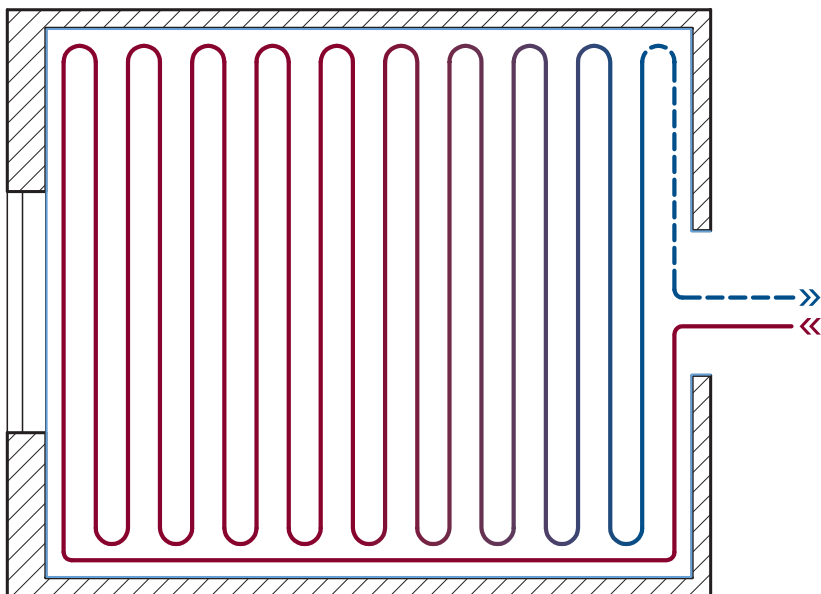

### Meander pattern

- + • The meander pattern is easy to lay
- BasicRail™, BasicClip™ and BasicGrip™ systems can be used
- • The meander pattern will distribute heating less uniformly across the room. In effect, some parts of the floor will be warmer than others

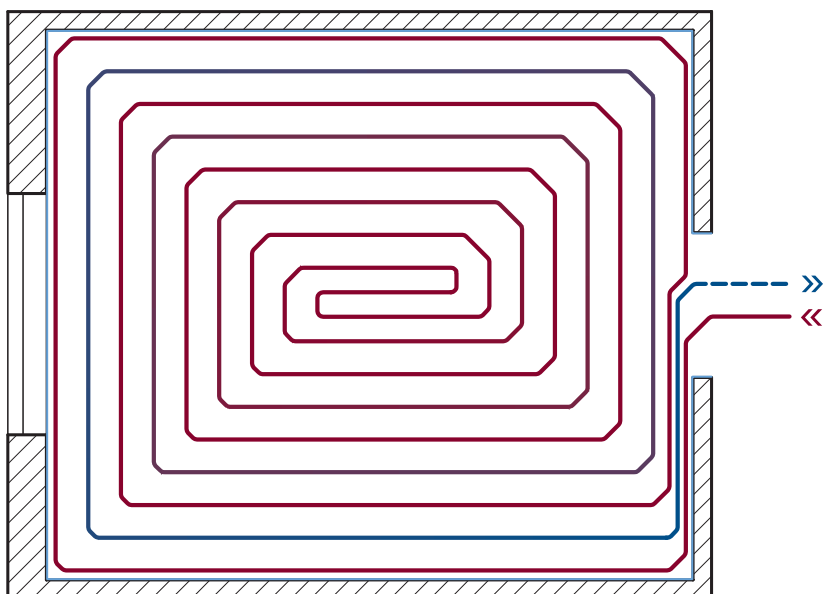

### Snail pattern

- + • Heating is equally distributed as supply and return water runs adjacent. This provides comfort compared to the meander pattern.
- • Requires more planning to lay
- Difficult to use BasicRail™

---

#### Pipe distance independent of pattern

##### type example:

Floor type:	Wooden floor
Heat requirement:	40 W/m <sup>2</sup>
Mean water temp.:	35 °C
Room temperature:	20 °C
<b>= Pipe distance</b>	<b>200 mm CC</b>

---

*For information about your specific building, please consult Danfoss.*

# Small windows vs. large windows

## Pipe distance

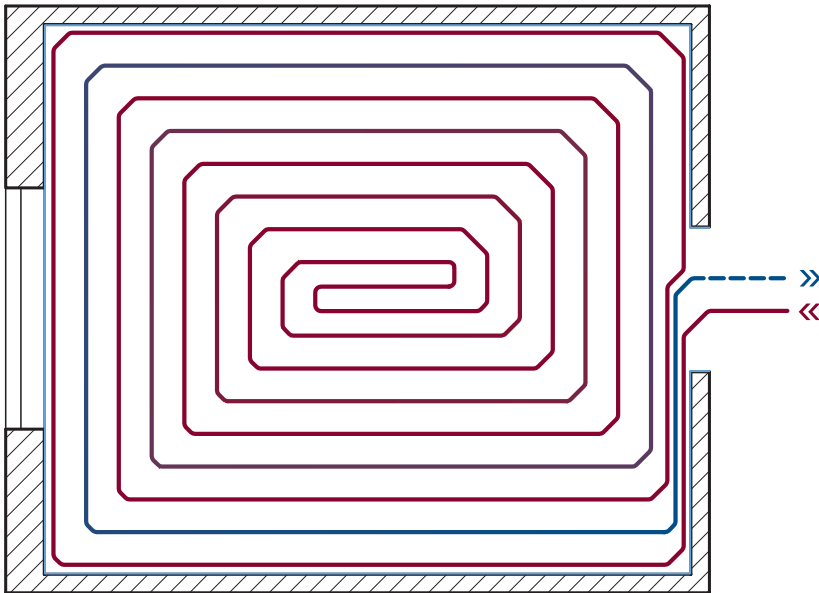

### Small or no windows

Smaller windows do not need to be taken into account as the downdraft is limited.

#### Example:

Floor type:	Tile floor
Heat requirement:	40 W/m <sup>2</sup>
Mean water temp.:	35 °C
Room temperature:	20 °C
<b>= Pipe distance</b>	<b>200 mm CC</b>

*For information about your specific building, please consult Danfoss.*

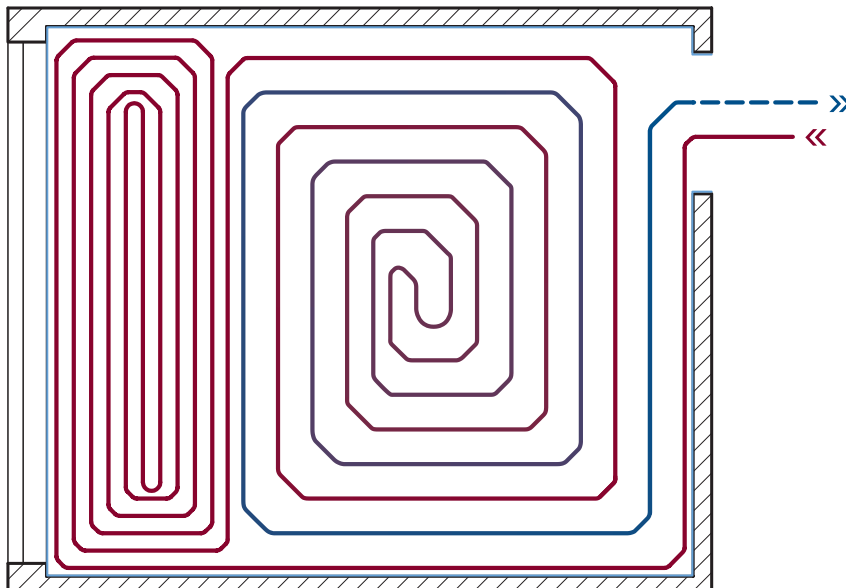

### Large floor-to-ceiling window

At larger windows the pipe distance must be reduced in order to account for downdraft from the windows.

#### Example:

Floor type:	Tile floor
Heat requirement:	92 W/m <sup>2</sup> (at the window)
Mean water temp.:	35 °C
Room temperature:	20 °C
<b>= Pipe distance, window</b>	<b>120 mm CC</b>
<b>= Pipe distance, rest</b>	<b>200 mm CC</b>

*For information about your specific building, please consult Danfoss.*

# Bathroom and kitchen

## Laying patterns and distance

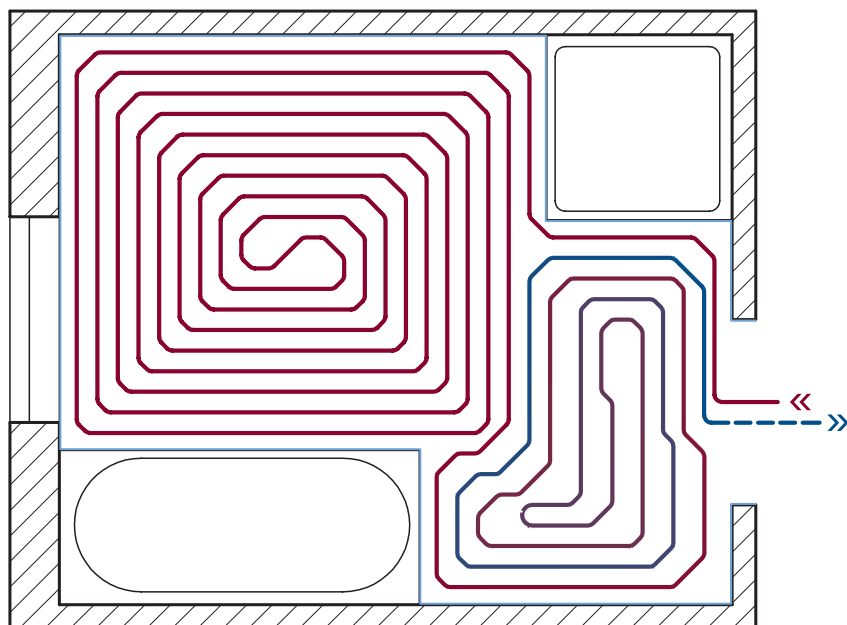

### Bathroom

Suggested snail pattern for a typical bathroom. Due to the requirement for higher temperatures in the bathroom, the pipe distance should be reduced.

#### Example:

Floor type:	Tile floor
Heat requirement:	67 W/m <sup>2</sup> (at the window)
Mean water temp.:	35 °C
Room temperature:	24 °C
<b>= Pipe distance, window</b>	<b>120 mm CC</b>

*For information about your specific building, please consult Danfoss.*

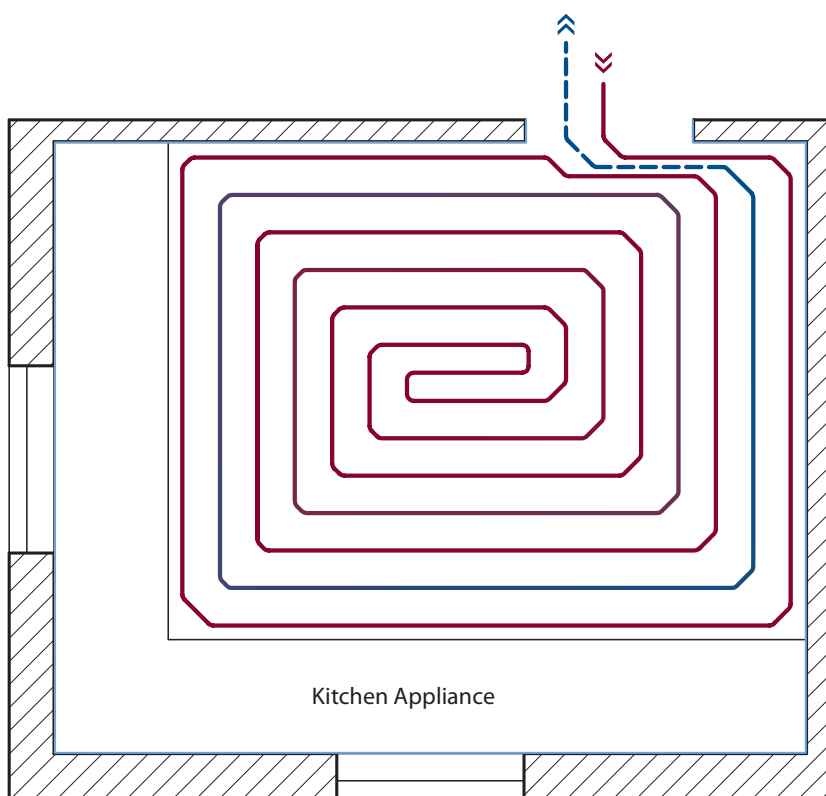

### Kitchen

Avoid placing pipes under the kitchen cabinets. If pipes are placed under the kitchen cabinets, the temperature in the cabinets will increase which is not optimal if they contain food.

#### Example:

Floor type:	Wooden floor
Heat requirement:	40 W/m <sup>2</sup>
Mean water temp.:	35 °C
Room temperature:	20 °C
<b>= Pipe distance</b>	<b>200 mm CC</b>

*For information about your specific building, please consult Danfoss.*

# Large rooms

## Laying patterns and distance

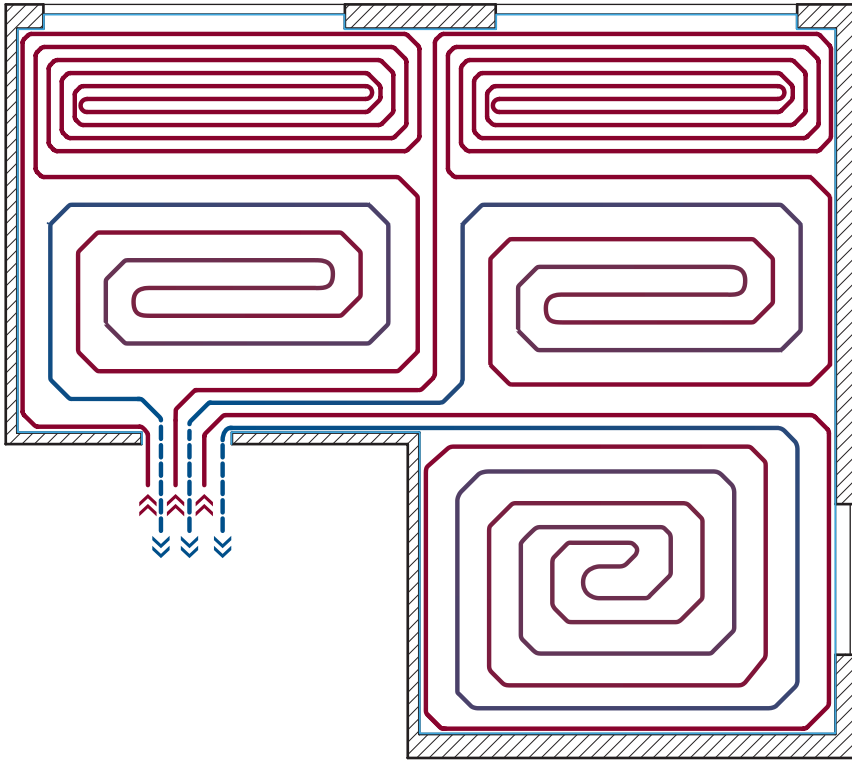

### Large rooms

Suggested snail pattern for a typical large room.

Due to the size of the room the number of circuits must be increased (in this example to three circuits).

---

#### Example:

Floor type:	Wooden floor
Heat requirement:	40 W/m <sup>2</sup>
Mean water temp.:	35 °C
Room temperature:	20 °C

**Number of circuits**     **3**

= Pipe distance, window     120 mm CC

= Pipe distance, rest     200 mm CC

---

*For information about your specific building, please consult Danfoss.*

# CHOOSING THE RIGHT FLOOR SCREED

Application guidelines for floor build-up.

Liquid and cement screed both ensure a smooth and even surface. However, the two types of screed each have different benefits and impact on floor thickness and weight.

# Liquid screed vs. cement screed

## Benefits and impact

### Liquid screed

- + • Floor **thickness** reduced compared to cement screed
- Floor **weight** reduced compared to cement screed
- Reducing thickness and weight can be important in e.g. renovations
  
- • Liquid screed is often more expensive

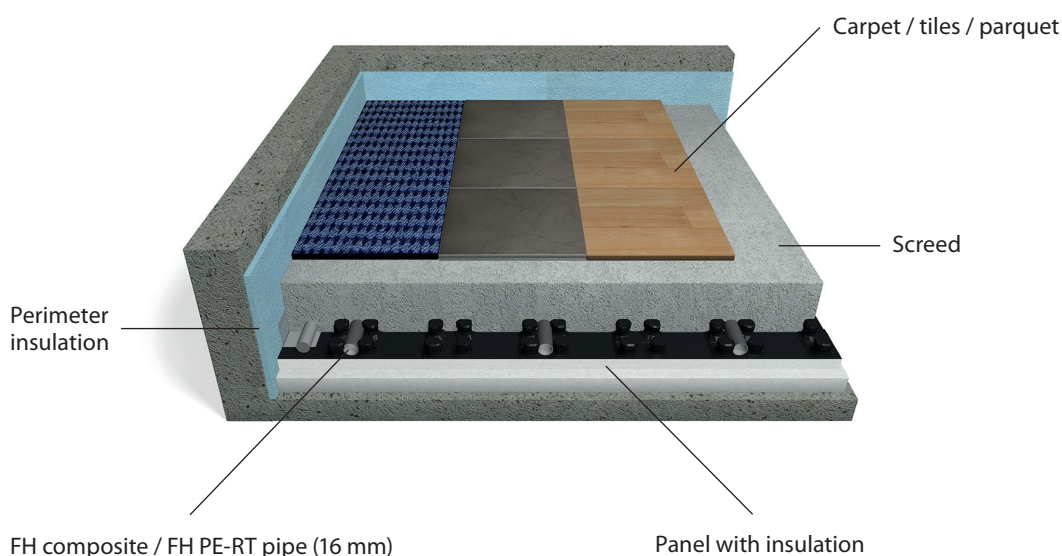

		Liquid *	Cement	
Screed thickness	[mm]	<b>65</b>	<b>85</b>	
Insulation thickness	[mm]	35	35	
Construction height	[mm]	<b>100</b>	<b>120</b>	Height excluding floor finish
Weight	[Kg/m <sup>2</sup> ]	<b>140</b>	<b>176</b>	Weight excluding floor finish
Thermal resistance (R)	[m <sup>2</sup> K/W]	0.87	0.87	Thermal resistance value for floor heating panel
Thermal transmission coefficient (U)	[W/m <sup>2</sup> K]	0.96	0.96	Check building regulation for thermal insulation requirement
Distribution load	[kN/mm <sup>2</sup> ]	<2.0	<2.0	
Point load (>20 cm <sup>2</sup> )	[kN]	<2.0	<2.0	
Impact subsonic noise reduction	[dB]	28	28	Calculated value according to DIN 4109. Applies to concrete slabs thicker than 12 cm (DIN 4109; m <sup>2</sup> > 276 kg/m <sup>2</sup> )

\* Example based on cement screed with CAF F5 additive. Using other CAF additives will impact thickness and weight.

# Pioneering heating controls for decades

Danfoss has been designing and developing heating control systems for more than 80 years. Throughout that time, it has been our goal to continuously innovate, perfect and refine cutting-edge heating and cooling solutions.



First sales of built-in valves (used in floor heating manifolds)

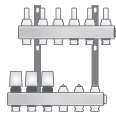

First manifold with Danfoss built-in valves



CF2 wireless room controls introduced with infrared sensor

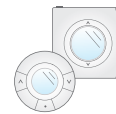

Launch of Danfoss Link™ floor heating and radiator thermostat

1943

1982

1996

1998

2002

2005

2007

2011

2017



Mads Clausen designs the world's first radiator thermostat



World's first wireless room control for floor heating introduced



Danfoss acquires PentaCom floor heating and launches its own TWA



Danfoss acquires Jupiter floor heating



Launch of Danfoss Icon™ 230 V Floor Heating Controls

## Danfoss A/S

Heating Segment • [heating.danfoss.com](http://heating.danfoss.com) • +45 7488 2222 • E-Mail: [heating@danfoss.com](mailto:heating@danfoss.com)

Danfoss can accept no responsibility for possible errors in catalogues, brochures and other printed material. Danfoss reserves the right to alter its products without notice. This also applies to products already on order provided that such alterations can be made without subsequential changes being necessary in specifications already agreed. All trademarks in this material are property of the respective companies. Danfoss and all Danfoss logotypes are trademarks of Danfoss A/S. All rights reserved.