

Data sheet

## Servo-operated 2/2-way solenoid valves

Type EV220B 65 - EV220B 100



EV220B 65 - EV220B 100 is a 2/2-way solenoid valve program for use in robust industrial applications, demanding high flow rates. The valve is designed with cast iron valve body and flanged connection. Water-hammer damped design and built-in pilot filter ensures a reliable operation.

### Features

- ☒ For water and similar neutral media
- ☒ Flow range for water KV: 50 - 130 m<sup>3</sup>/h
- ☒ Ambient temperature: Up to 80 °C
- ☒ Differential pressure: Up to 10 bar
- ☒ Viscosity: Up to 50 cSt
- ☒ Coil enclosure: Up to IP67
- ☒ Flange connections: 2 ½, 3 and 4"
- ☒ Water hammer damped
- ☒ Built-in filter for protection of pilot system
- ☒ Seal material: EPDM and NBR

# ЮГОВ - Проект

інженерно-виробниче підприємство

Офіційний дистриб'ютор  
Danfoss в Україні[ugov.ua](http://ugov.ua)

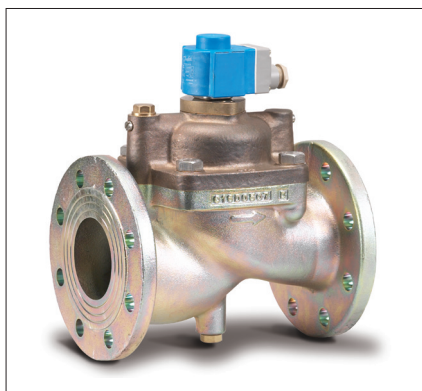
**EV220B 65-100  
Valve body with flange  
connection**

Connection ISO 228/1	Seal material	Orifice size [mm]	kv - value [m <sup>3</sup> /h]	Differential pressure, min. to max. [bar]	Media temperature min. to max. [°C]	Code number
2 ½	EPDM	65	50	0.25 – 10	-25 – 90	<b>016D6065</b>
2 ½	NBR	65	50	0.25 – 10	-25 – 90	<b>016D3330</b>
3	EPDM	80	75	0.25 – 10	-25 – 90	<b>016D6080</b>
3	NBR	80	75	0.25 – 10	-25 – 90	<b>016D3331</b>
4	EPDM	100	130	0.25 – 10	-25 – 90	<b>016D6100</b>

<sup>1)</sup> It is recommended to use filter in front of the valve. Recommended filter 50 mesh (297 microns).

<sup>2)</sup> In water applications, exercise the valves at least once every 24 hours, meaning change the state of the valve. The valve exercise will minimize the risk of the valve sticking due to calcium carbonate, zinc or iron oxide build-up.

<sup>3)</sup> To minimize scaling, and corrosion attack it is recommended that the water passing the valve have the following values:

- Hardness 6-18 °dH to avoid scaling (chalk / lime stone build up)
- Conductivity 50 – 800 µS/cm to avoid brass dezincification and corrosion.
- Above 25°C media temperature avoid stagnant water inside the valve to avoid dezincification and corrosion attack.

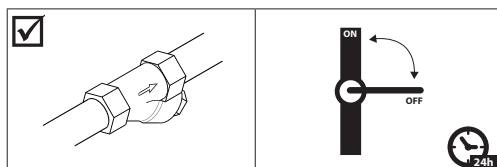

**Technical data**

Main type	EV220B 65	EV220B 80	EV220B 100
Time to open [s] <sup>1)</sup>	5	5	5
Time to close [s] <sup>1)</sup>	7	15	29

<sup>1)</sup> The times are indicative and apply to water.

Type	EV220B 65 - EV220B 100		
Installation	Vertical solenoid system is required (see page 5, mounting angle)		
Max. test pressure	15 bar		
Ambient temperature	Up to 80 °C		
Viscosity	Max. 50 cSt		
Materials	Valve body:	Cast iron	W.no. 0.6020
	Armature:	Stainless steel	W.no. 1.4105/AISI 430L
	Armature tube:	Stainless steel	W.no. 1.4306/AISI 304L
	Springs:	Stainless steel	W.no. 1.4310/AISI 301
	Pilot body	Brass	–
	Ring	Copper	–
	EPDM version	NBR, Cetellen WS3820, PTFE, EPDM, CR	–
NBR version	NBR, centellen WS3820, PTFE	–	
Media	EPDM version	Water, Brine, Glycol	–
	NBR version	Air, Oil	–

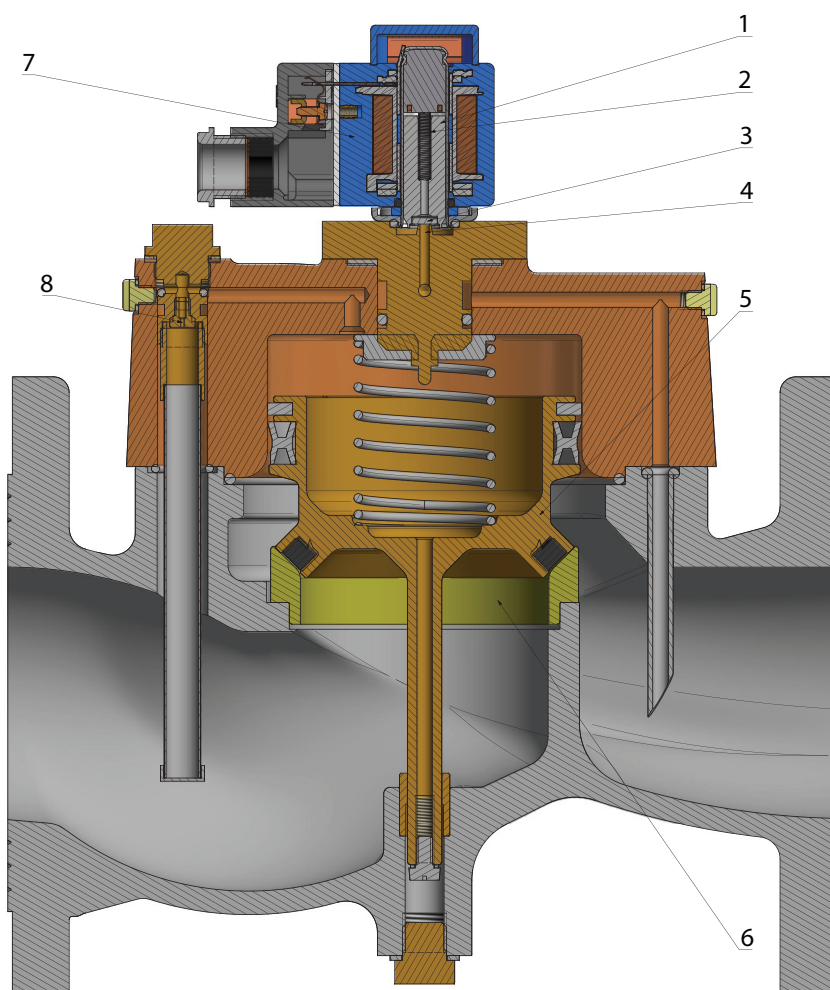
**Function**



- 1. Armature
- 2. Closing spring in pilot system
- 3. Valve plate
- 4. Pilot orifice
- 5. Servo piston
- 6. Main orifice
- 7. Coil
- 8. Equalizing orifice

*Coil voltage disconnected (closed):*

When the voltage is disconnected, the valve plate (3) is pressed down against the pilot orifice (4) by the pilot system's closing spring (2).

The pressure across the servo piston (5) is built up via the equalizing orifice (8). The servo piston closes the main orifice (6) as soon as the pressure across the piston is equivalent to the inlet pressure.

The valve will be closed for as long as the voltage to the coil is disconnected.



*Coil voltage connected (open):*

When voltage is applied to the coil (7), the armature (1) and the valve plate (3) are lifted clear of the pilot orifice (4). As the pilot orifice is larger than the equalizing orifice (8), the pressure across the servo piston (5) drops and therefore it is lifted clear of the main orifice (6).

The valve will be open for as long as the minimum differential pressure across the valve is maintained, and for as long as there is voltage to the coil.

**Data sheet | Solenoid valves, type EV220B 65 - EV220B 100**

**Below coils can be used with EV220B**

Coil	Type	Power consumption	Enclosure	Features
	BB, clip on	10 W AC 18 W DC	IP00 with spade connector	IP20 with protective cap, IP65 with cable plug
	BE, clip on	10 W AC 18 W DC	IP67	With terminal box
	BG, clip-on	12 W AC 20 W DC	IP67	With terminal box

**Accessories:  
Cable plug**

Application	Code number
GDM 2011 (grey) cable plug according to DIN 43650-A PG11	<b>042N0156</b>

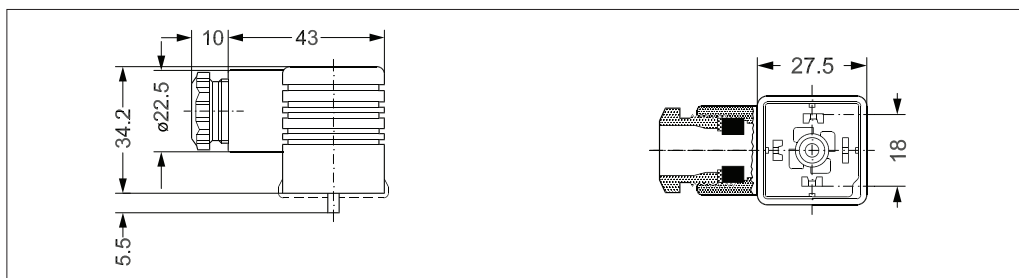

**Ordering of flange set**

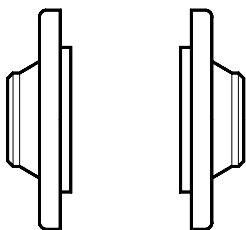

Connection	Type	Code number
2 ½ weld type 11 according to DIN EN 1092-1	EV220B 65	<b>027N3065</b>
3 weld type 11 according to DIN EN 1092-1	EV220B 80	<b>027N3080</b>
4 weld type 11 according to DIN EN 1092-1	EV220B 100	<b>027N3100</b>

**Manuel override kit,  
hand operated**

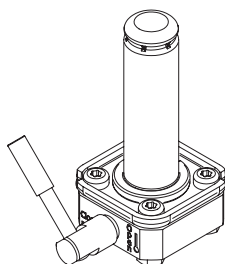

Seal material	Description	Code number
EPDM	Manuel override kit. used for manuel override in event of power failure.] Note: Valve height is increased by 16 mm	<b>032U7390</b>

## Data sheet | Solenoid valves, type EV220B 65 - EV220B 100

### Dimensions and weight

Type	L [mm]	L <sub>1</sub> [mm]	Required min. L <sub>2</sub> * (mm)	B <sub>1</sub> [mm] Coil type		øD [mm]	H <sub>1</sub> [mm]	H <sub>2</sub> [mm]	Weight without coil [kg]	Required min. inside tube diameter d** (mm)
				BB/BE	BG					
EV220B 65	320	224	300	46	66	185	85	185	24	65
EV220B 80	370	265	350	46	66	200	93	215	34	80
EV220B 100	430	315	400	46	66	220	103	240	44	100

### Dimensions

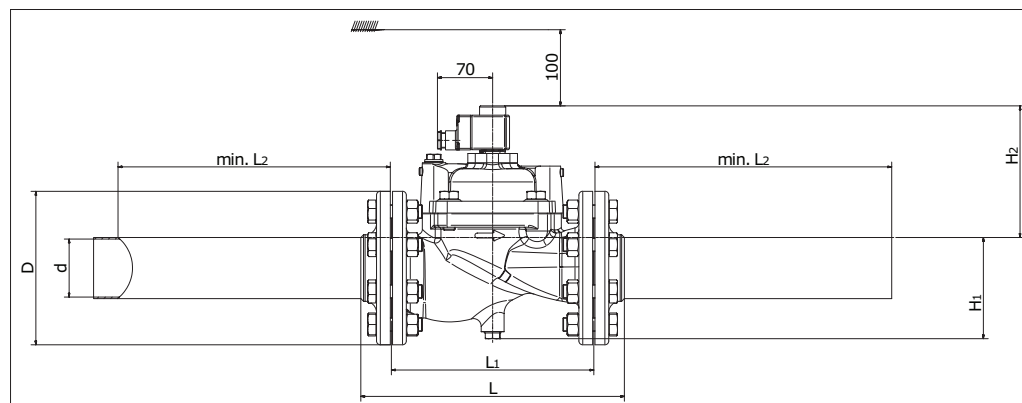

\*Avoid closing problems caused by turbulent flow it is required to have a straight tube on both sides of the valve.

\*\* Required to keep same tube size for entire application, same or bigger inside diameter as valve orifice 65 / 80 / 100 mm

### Mounting angle

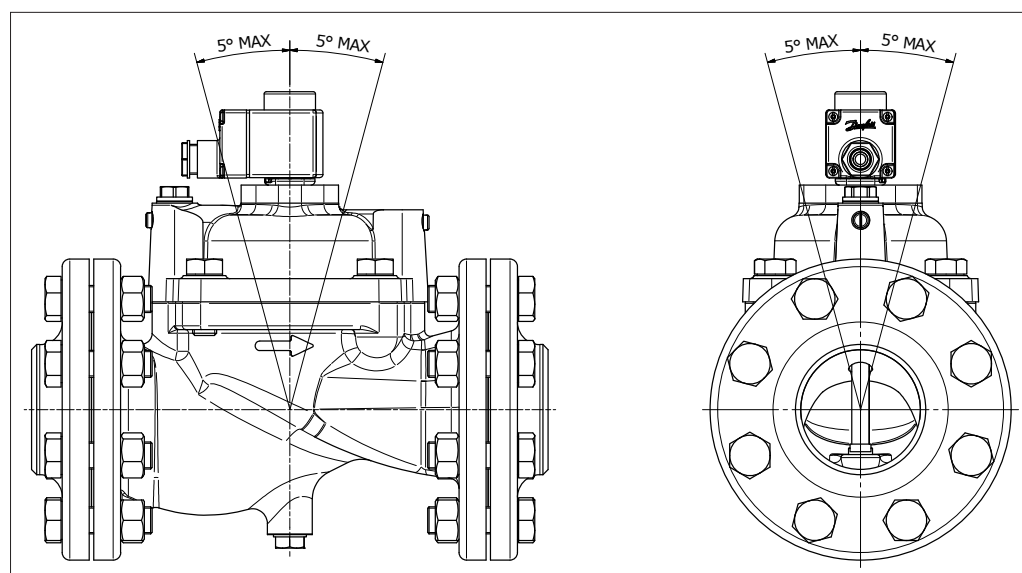

Application diagram

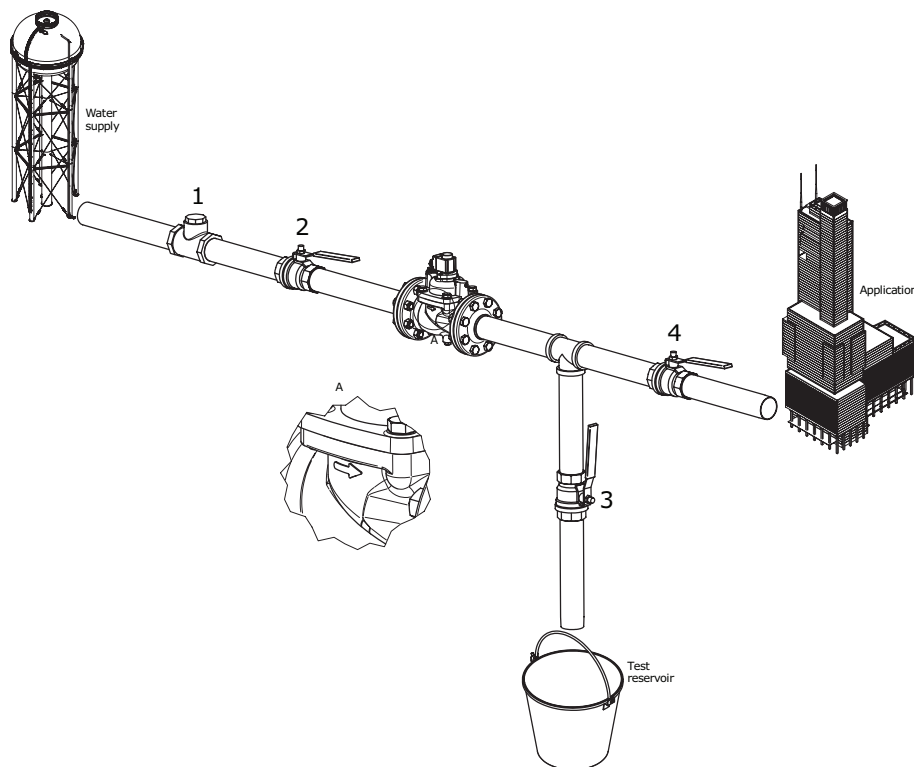

NO.	Part
1	Filter
2	Ball valve, Water supply
3	Ball valve, Test reservoir
4	Ball valve, Application

Capacity diagram for EV220B 65 - 100

Example, water:  
Capacity for EV220B 65 at differential pressure of 4 bar: Approx. 100 m<sup>3</sup>/h

Recommended operating range:  
Grey area 1-6 bar differential pressure.

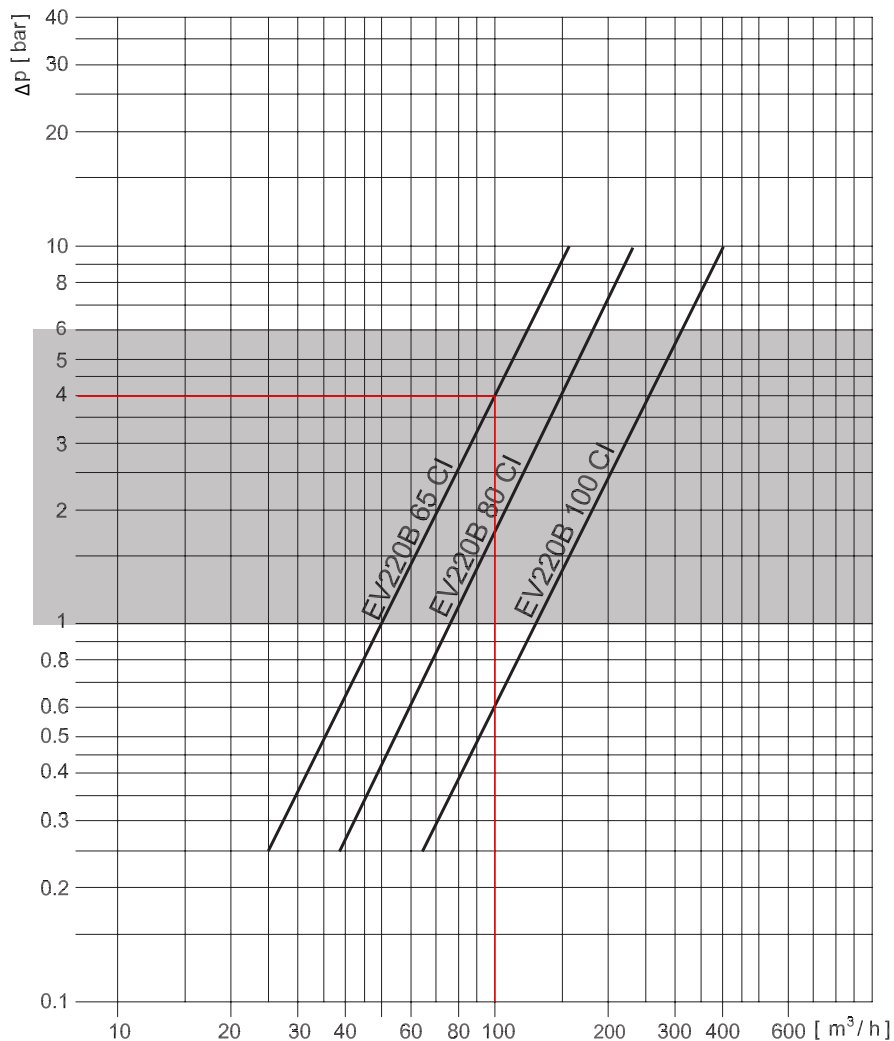

### Periodic maintenance/inspection

Maintenance/Inspection every 6 to 12 months recommended.

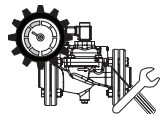

**Before starting maintenance/inspection be sure:**

- Coil is not energized when removed from the armature tube.
- System/solenoid valve is not pressurised. Eventually close ball valves on each side of the valve.
  - Be sure any pumps on the upstream (inlet supply) will not be energized or a pressure sensor or switch will not start the pump.
- After cleaning and service, eventually with Danfoss spare part kit, it is recommended to lubricate piston and piston sealing with a thin layer of lubrication included into the spare part kit.

Frequency and maintenance depend largely on the application and the medium used in the valve. Mechanical contaminants, iron, excessive mineralization, through the valve or may cause problems with the operation of the valves. All maintenance and repair work should be carried out by technically trained personnel who are familiar with the operation of the installation.

In case of large impurities visible on the filter, piston scale and cover, other impurities inside the valve, the frequency of inspections should be increased.

Sparepart kits  
DN65 - DN100

Type	Spare part kit EPDM	Spare part kit NBR	Seal kit EPDM	Seal kit NBR
EV220B 65	<b>016D0078</b>	<b>016D0095</b>	<b>016D0075</b>	<b>016D0084</b>
EV220B 80	<b>016D0079</b>	<b>016D0096</b>	<b>016D0076</b>	<b>016D0085</b>
EV220B 100	<b>016D0080</b>	–	<b>016D0077</b>	<b>016D0086</b>
	<p>1. Armature +Spring 2. 2x O-ring 3. O-ring 4. Piston 5. O-ring</p>		<p>1. Steam gasket 2. 2x Sealing 3. Sealing 4. O-ring 5. Rubber gasket 6. O-ring 7. O-ring 8. 2x Steam gasket 9. O-ring 10. O-ring 11. Filter holder 12. Orifice 13. Filter 14. Drain plug</p>	

For detailed guidance see installation guides for EV220B 65-100 valve, spare part kit and seal kit