

Data sheet

Polymer solenoid valves for water inlet

Type EV220T



Middle size valve range for water fluid controls for washing and processing machines / applications:

- Inlet / shut off valves for Applications
- Laundry
- Dishwashing
- Carwash
- Industrial Processing
- Irrigation

Features and versions

- Clip-on coil
- Flow range for water in Kv: 4 and 6 m³/h
- Differential pressure: 0,3 – 10 bar
- Media temperature from 0 – 85 °C
- Ambient temperature: Up to 80 °C
- Coil enclosure: IP65
- DN 14 and 18
- Water hammer damped
- Built-in filter
- EV220T 14-18, NC, polymer

EV220T
Polymer valve body, NC



- WRAS
- In accordance with:
 - Low Voltage Directive 2014/35/EU
 - EN60730-1
 - EN60730-2-8
 (Notified body by Semko)
- Pressure Equipment Directive 2014/68/EU
- RoHS Directive 2011/65/EU
- UL recognized

G thread connection

ISO 228-1 connection		Seal material	Orifice size [mm]	K _v -value [m ³ /h]	Media temp. [°C]	Differential pressure [bar]	Code no.
Inlet	Outlet						
G 3/4 ext.	3/4 hose	EPDM	DN 14	4	0 – 85	0.3 – 10	042U8105
G 3/4 ext.	G 3/4 ext.	EPDM	DN 14	4	0 – 85	0.3 – 10	042U8125
G 3/4 ext.	3/4 hose	EPDM	DN 18	6	0 – 85	0.3 – 10	042U8155
G 3/4 ext.	G 3/4 ext.	EPDM	DN 18	6	0 – 85	0.3 – 10	042U8175

See separate table for AS/AZ coils.

NPSM thread connection

NPSM connection		Seal material	Orifice size [mm]	K _v -value [m ³ /h]	Media temp. [°C]	Differential pressure [bar]	Code no.
Inlet	Outlet						
3/4-14 NPSM ext.	3/4-14 NPSM ext.	EPDM	DN 14	4	0 – 85	0.3 – 10	042U8135
3/4-14 NPSM ext.	3/4-14 NPSM ext.	EPDM	DN 18	6	0 – 85	0.3 – 10	042U8185

See separate table for AS/AZ coils.

GH thread connection

Garden Hose connection (GH)		Seal material	Orifice size [mm]	K _v -value [m ³ /h]	Media temp. [°C]	Differential pressure [bar]	Code no.
Inlet	Outlet						
3/4 - 11.5 NH	3/4 hose	EPDM	DN 14	6	0 – 85	0.3 – 10	042U8145
3/4 - 11.5 NH	3/4 hose	EPDM	DN 18	6	0 – 85	0.3 – 10	042U8195

See separate table for AS/AZ coils.

¹⁾ It is recommended to use a filter in front of the valve.

²⁾ In water applications, exercise the valves at least once every 24 hours, meaning change the state of the valve. The valve exercise will minimize the risk of the valve sticking due to calcium carbonate, zinc or iron oxide build-up.

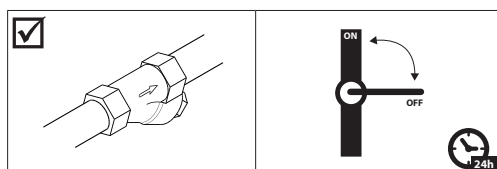

Technical data

Type	EV220T 14	EV220T 18
Time to open [ms] ¹⁾	100	200
Time to close [ms] ¹⁾	400	500
Capacity, K _v [m ³ /h]	4	6
Capacity [C _v gal/min]	4.7	7

¹⁾ Times are indicative and apply to water. Exact times will depend on pressure conditions.

Valve	Max. working pressure (MWP)	10 bar	
	Max. test pressure	15 bar	
	Ambient temperature	Max. 50 °C / 122 °F	
	Media viscosity	50 cSt	
Materials	Body	EMS Grivory HT (Glass-fiber reinforced)	
	Armature	Stainless steel	W no. 1.4105 / AISI 430FR
	Armature stop	Stainless steel	W. no. 1.4105 / AISI 430FR
	Armature tube	Stainless steel	W. no. 1.4303 / AISI 305
	Spring	Stainless steel	W. no. 1.4310 / AISI 301
	O-ring	EPDM	
	Valve plate	EPDM	
	Diaphragm	EPDM	
Features	Mounting	Metal bracket (see dimension drawing on page 4)	
	Media	Built-in filter mesh width 0.45 mm	

Function

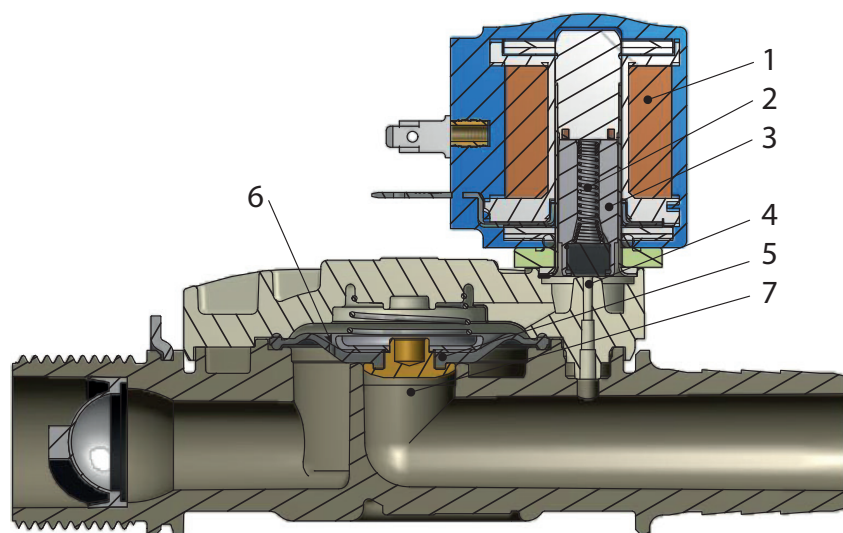

Pos. no.	Description
1	Coil
2	Armature spring
3	Armature
4	Pilot orifice
5	Diaphragm
6	Equalizing orifice
7	Main orifice

Coil voltage disconnected

When voltage is disconnected, the armature spring (2) presses the armature (3) down against the pilot orifice (4). Pressure builds up over the diaphragm (5) via the equalizing orifice (6). The diaphragm (5) closes the main orifice (7) as soon as the pressure over the diaphragm equals the inlet pressure. The valve stays closed for as long as voltage remains disconnected.

Coil voltage connected (open)

When voltage is applied to the coil (1), the pilot orifice (4) is opened. Since the pilot orifice is larger than the equalizing orifice (6), pressure over the diaphragm (5) falls and the diaphragm is lifted clear of the main orifice (7). The valve stays open for as long as the required minimum differential pressure is present and voltage is applied to the coil.

Dimensions and weight

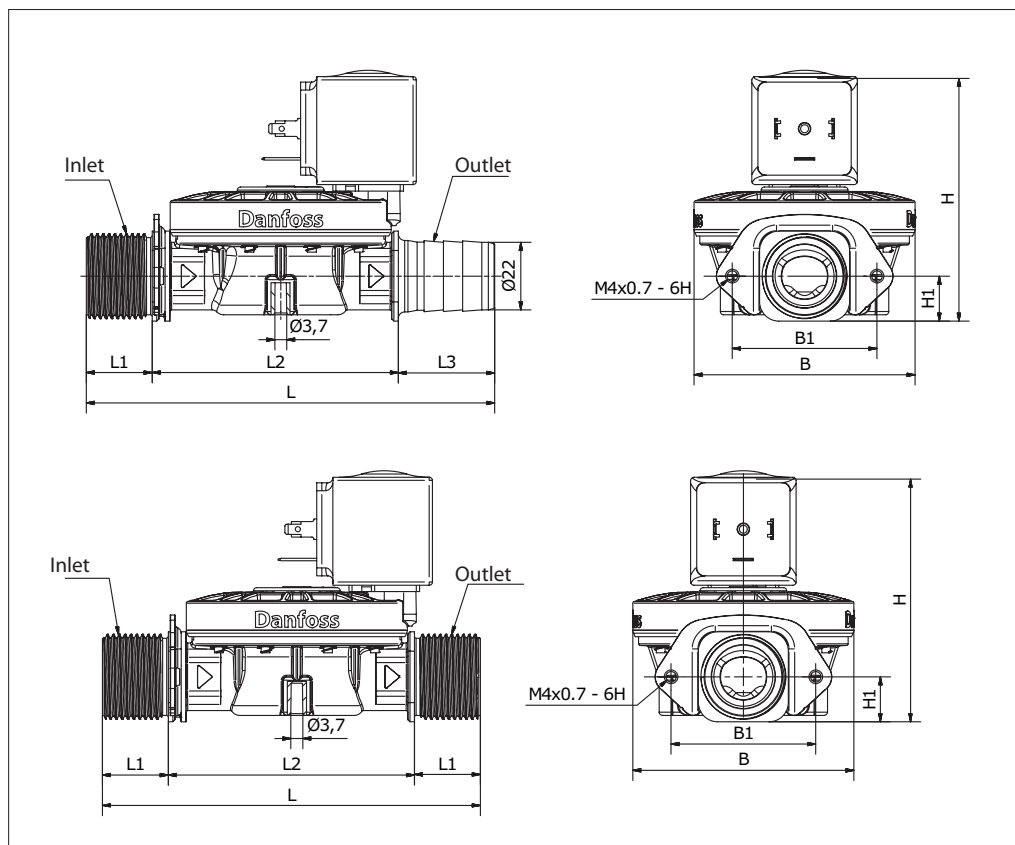

G thread connection

Orifice size [mm]	ISO 228-1 connection		L	L1	L2	L3	B	B1	H	H1
	Inlet	Outlet	[mm]	[mm]	[mm]	[mm]	[mm]	[mm]	[mm]	[mm]
DN 14	G 3/4 ext.	G 3/4 ext.	117.5	20.5	76.5	—	68.8	45.0	77.7	14.0
DN 14	G 3/4 ext.	3/4 Hose	127.5	20.5	76.5	30.0	68.8	45.0	77.7	14.0
DN 18	G 3/4 ext.	G 3/4 ext.	117.5	20.5	76.5	—	68.8	45.0	79.9	14.0
DN 18	G 3/4 ext.	3/4" Hose	127.5	20.5	76.5	30.0	68.8	45.0	79.9	14.0

NPSM thread connection

Orifice size [mm]	NPSM connection		L	L1	L2	L3	B	B1	H	H1
	Inlet	Outlet	[in]	[in]	[in]	[in]	[in]	[in]	[in]	[in]
DN 14	3/4 - 14 NPSM ext.	3/4 - 14 NPSM ext.	4.61	0.81	2.99	—	2.78	1.77	3.03	0.55
DN 14	3/4 - 14 NPSM ext.	3/4 Hose	5.0	0.81	2.99	1.18	2.78	1.77	3.03	0.55
DN 18	3/4 - 14 NPSM ext.	3/4 - 14 NPSM ext.	4.61	0.81	2.99	—	2.78	1.77	3.11	0.55
DN 18	3/4 - 14 NPSM ext.	3/4 Hose	5.0	0.81	2.99	1.18	2.78	1.77	3.11	0.55

Valve type	Gross weight Valve body without coil [kg]	Gross weight Valve body including AM coil, plug [kg]
EV220T 14 - 18	0.16	0.30

GH thread connection

Orifice size [mm]	Garden Hose connection		L	L1	L2	L3	B	B1	H	H1
	Inlet	Outlet	[mm]	[mm]	[mm]	[mm]	[mm]	[mm]	[mm]	[mm]
DN 14	3/4 - 11.5 NH	3/4 hose	127.5	20.5	76.5	30.0	68.8	45.0	77.7	14.0
DN 18	3/4 - 11.5 NH	3/4 hose	127.5	20.5	76.5	30.0	68.8	45.0	77.7	14.0

Mounting angle

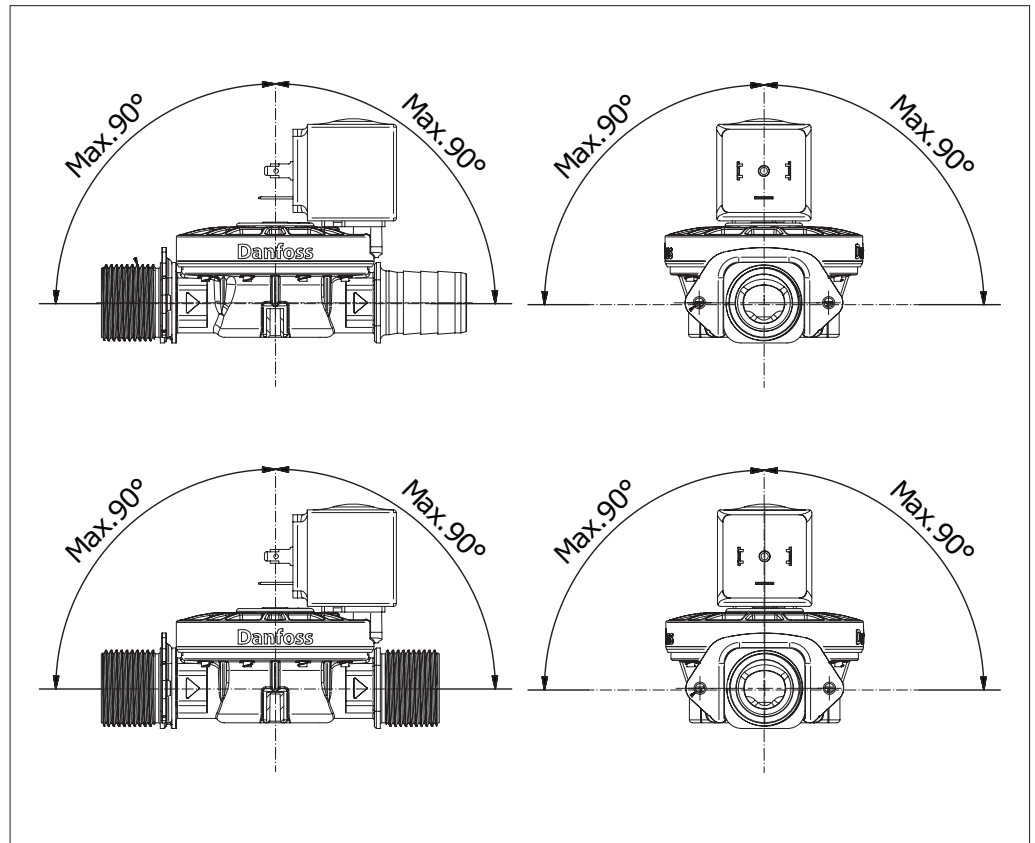

Capacity diagram

Example for water:
Capacity for EV220T at a
differential pressure of 3
bar: Approx. 7 m³/h

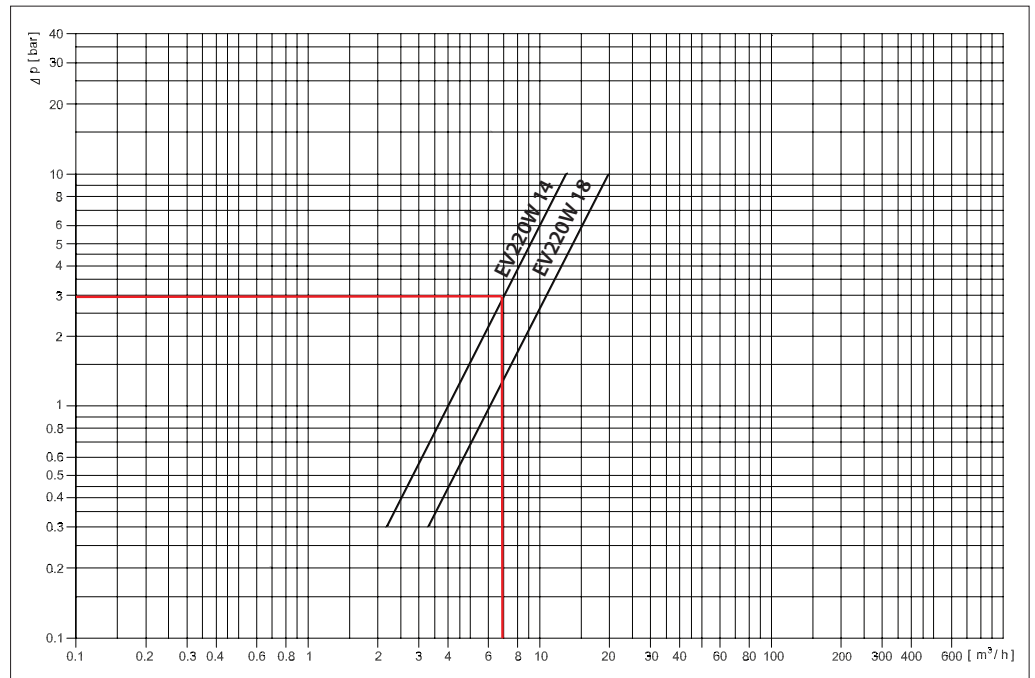

**AS/AZ,
Compact UL recognised,
clip-on coils**



- Enclosure:
Up to IP65 / NEMA 4
- Used with EV220T and EV220W
- For UL recognised valves
- In accordance with:
 - Low Voltage Directive 2014/35/EU
 - EN60730-1
 - EN60730-2-8
 (Notified body by Semko)
 - RoHS Directive 2011/65/EU

Type	Tambient [°C]	Supply voltage [V]	Voltage variation	Frequency [Hz]	Power consumption		Approval	Code no.
					[W]	[VA]		
AS024CS	-40 – 50	24	-10%, +6%	50	9.5	18		042N7608
		24	-10%, +6%	60	7.0	14		
AS230CS	-40 – 50	230	-10%, +6%	50	8.0	16		042N7601
		208 - 240	±6%	60	7.0	14		
AZ012DS	-40 – 50	12	-10%, +6%	DC	6.0	-		042N7616
AZ024DS	-40 – 50	24	-10%, +6%	DC	6.5	-		042N7617

Technical data

Design	In accordance with UL 429
Insulation of coil windings	Class H according to IEC 85
Connection	Spade connector in accordance with DIN 43650 form A
Enclosure, IEC 529	IP00 with DIN spade connector, IP65 with cable plug
Plug type	Cable plug (042N0156)

Dimensions and weight

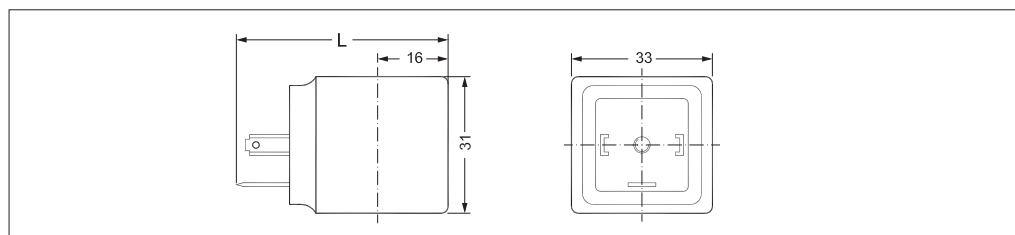

L without cable plug [mm]	L with cable plug [mm]	L with protective cap [mm]	Weight [kg]
48	72	64	0.10

Accessories:
Cable plug



Type, Form A	Code no.
GDM 2011 (grey) cable plug according to DIN 43650-A PG11	042N0156

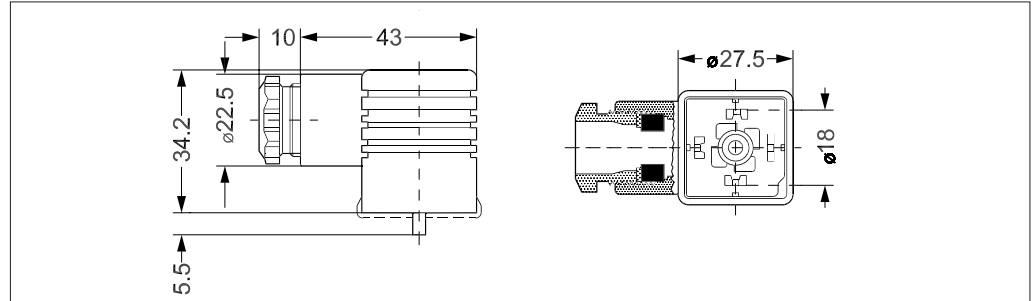

Built-in filter



Type	Code number
Built-in filter mesh width 0.45 mm	042U8199