

# Mini Contactors CI 4-

## Introduction



CI 4 minicontactors cover the power range 1.5 to 5.9 kW and are available for a.c. and d.c. coil voltages. Characteristic of the minicontactors is that they are compact. With add-on auxiliary contact blocks and a timer they offer high flexibility.

The CI 4- range includes low-power d.c. coils, especially for PC and PLC control.

The CI 4- range is particularly suitable for applications where space is at a premium.

In addition, the CI 4- range also includes thermal overload relays for the protection of squirrel-cage motors.

## Ordering

### Minicontactors CI 4-, for a.c. coil voltage

AC-3 load			Main circuit			Built-in auxiliary contacts Number/Function	Code no. <sup>1)</sup>	Type
U <sub>e</sub> 220-240 V kW	U <sub>e</sub> <b>380-500 V</b> kW	I <sub>e</sub> <sup>1)</sup> A	I <sub>th</sub> <sup>1)</sup> (AC-1) Open A	I <sub>the</sub> <sup>2)</sup> (AC-1) Encl. A	Main contacts number A			
1.1	<b>1.5</b>	3.7	16	12	-	4 NO	<b>037H3210</b>	CI 4-2 <sup>2)</sup>
1.1	<b>1.5</b>	3.7	16	12	-	2 NO, 2 NC	<b>037H3211</b>	CI 4-2 <sup>2)</sup>
1.5	<b>2.2</b>	5.3	20	16	3	1 NO	<b>037H3114</b>	CI 4-5
1.5	<b>2.2</b>	5.3	20	16	3	1 NC	<b>037H3115</b>	CI 4-5
3.0	<b>4.0</b>	9	20	16	3	1 NO	<b>037H3116</b>	CI 4-9
3.0	<b>4.0</b>	9	20	16	3	1 NC	<b>037H3117</b>	CI 4-9
3.0	<b>4.0</b>	9	20	16	4	-	<b>037H3118</b>	CI 4-9
3.3	<b>5.9</b>	12	20	16	3	1 NO	<b>037H3457</b>	CI 4-12
3.3	<b>5.9</b>	12	20	16	3	1 NC	<b>037H3458</b>	CI 4-12

<sup>1)</sup> Coil voltage/frequency or Suffix no. (see table below) must be added to the Danfoss code no.

<sup>2)</sup> The thermal current value I<sub>th</sub> gives the maximum load at 40°C, which corresponds to installing the contactor in air (open).

<sup>3)</sup> The thermal current value I<sub>the</sub> gives the maximum load at 60°C, corresponding installing the contactor inside an enclosure.

### a.c. coil voltages for CI 4-

Coil voltage <sup>1)</sup>	Suffix no.
24 V, 50/60 Hz	13
110 V, 50 Hz 110 - 120 V, 60 Hz	23
220-230 V, 50 Hz 230-240 V, 60 Hz	32
240 V, 50/60 Hz	33
380-400 V, 50 Hz 400-415 V, 60 Hz	37

<sup>1)</sup> Standard coil voltage tolerance -15%, +10%

### Correct ordering of contactors

Example: CI 4-5 with NC auxiliary contact and 24 V, 50/60 Hz coil voltage.

Select one of the following two forms of ordering:

1. Danfoss code no. + Suffix no.:

037H3115.13

or

2. Danfoss code no. + coil voltage/frequency:

037H3115, 24 V/50 Hz

Ordering

Minicontactors CI 4-, for d.c. coil voltage

Main circuit						Built-in auxiliary contacts Number/Function	Code no. <sup>1)</sup>	Type
AC-3 load			I <sub>th</sub> <sup>1)</sup> (AC-1) Open A	I <sub>the</sub> <sup>2)</sup> (AC-1) A	Main (AC-1) (make) A			
U <sub>e</sub> 220-240 V kW	U <sub>e</sub> 380-500 V kW	I <sub>e</sub> <sup>1)</sup> A						
1.1	1.5	3.7	16	12	-	4 NO	037H3212	CI 4-2 <sup>2)</sup>
1.1	1.5	3.7	16	12	-	2 NO, 2 NC	037H3213	CI 4-2 <sup>2)</sup>
1.5	2.2	5.3	20	16	3	1 NO	037H3143	CI 4-5
1.5	2.2	5.3	20	16	3	1 NC	037H3144	CI 4-5
3.0	4.0	9	20	16	3	1 NO	037H3145	CI 4-9
3.0	4.0	9	20	16	3	1 NC	037H3146	CI 4-9
3.0	4.0	9	20	16	4	-	037H3147	CI 4-9
4.0	5.9	12	20	16	3	1 NO	037H3459	CI 4-12
4.0	5.9	12	20	16	3	1 NC	037H3460	CI 4-12

- <sup>1)</sup> Coil voltage/frequency or Suffix no. (see table below) must be added to the Danfoss code no.
- <sup>2)</sup> The thermal current value I<sub>th</sub> gives the maximum load at 40°C, which corresponds to installing the contactor in air (open).
- <sup>3)</sup> The thermal current value I<sub>the</sub> gives the maximum load at 60°C, corresponding installing the contactor inside an enclosure.

d.c. coil voltages for CI 4-

Coil voltages <sup>1)</sup>	Suffix no
* 12 V dc	01
24 V, dc	02

- <sup>1)</sup> Standard coil voltage tolerance -15%, +10%
- \* Code no. 037H3145 only

Auxiliary contact blocks CBM for CI 4-



Auxiliary contact CBM-

Contact function	Load				Code no.	Type
	I <sub>e</sub> (AC - 15) A	I <sub>th</sub> <sup>*)</sup> (AC-1) Open A	I <sub>the</sub> <sup>*)</sup> (AC-1) Encl. A	U <sub>e</sub> V		
4 make (NO)	2	10	6	500	037H3149	CBM-40
2 break (NC)					037H3150	CBM-02
1 make (NO) + 1 break (NC)					037H3151	CBM-11
2 make (NO) + 2 break (NC)					037H3152	CBM-22
4 break (NC)					037H3369	CBM-04

<sup>\*)</sup> I<sub>th</sub> and I<sub>the</sub> are defined and specified under Technical data.

Built-in auxiliary contacts and auxiliary contacts CBM- are force-actuated and suitable for safety switching.

The silver tips on the moveable auxiliary contact CBM- are cross stamped and PLC-compatible. Min. load 24 V, 10 mA.

Accessories for minicontactors CI 4-



Mech. interlock

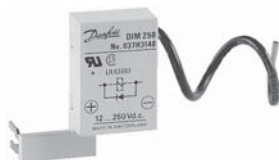

Diode element  
DIM 250



RC element  
RCM



Clip-on timer  
ETM-ON

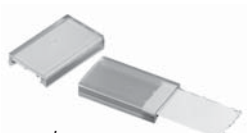

Clip-on markers



Base for ETM-ON



3-pole jumper

Description	Comments	Code no.
Mech. interlock	Mech. interlock can be established between pairs (Applies only to versions with a.c. coils)	<b>037H3157</b>
Diode element	Reduces overvoltage on de-energization of coils Type DIM 250 (12-250 V, d.c.)	<b>037H3148</b>
RC Element	Reduces overvoltage on de-energization of coils Type RCM 48 (24-48 V, 50/60 Hz)	<b>037H3155</b>
	Type RCM 280 (110-280 V, 50/60 Hz)	<b>037H3156</b>
Clip-on timer	Clip-on timer (On-delay) Time range 1-30 s, voltage range 110-250 V a.c./d.c. Type ETM-ON	<b>037H3153</b>
Clip-on markers	Rating plate with cover (100-off)	<b>037H3142</b>
DIN-rail base for ETM-ON	For DIN rail mounting of clip-on timer ETM-ON, suitable for 35 mm DIN rail and 32 mm C rail	<b>037H3154</b>
3-pole jumper	For single-phase loads and star point connection (50-off)	<b>037H0169</b>

Introduction

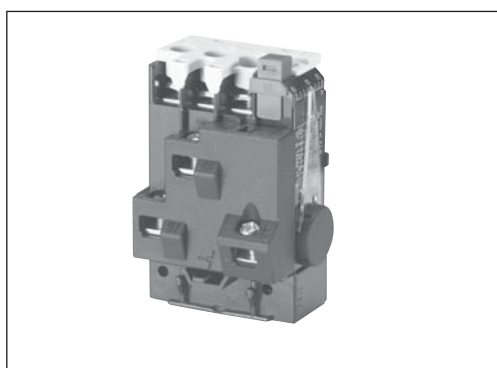

Thermal overload relays TI 9C are used with mini-contactors CI 4- for protection of squirrel-cage motors where compactness is required.

The relays have single-phase protection, i.e. accelerated release if phase drop-out occurs. This is particularly important for motors with delta-connected windings.

Other features of TI 9C:

- stop/reset button
- manual/automatic reset
- test button
- double scale for direct start or Y/D start
- galvanically isolated signal contact

Ordering

Thermal overload relays TI 9C and 12C, for minicontactors CI 4-

Range		Max. fuse <sup>1)</sup>				HRC <sup>2)</sup> Form II	Code no.	Type
Motor starter A	Y/D-starter A	gl, gL, gG		BS 88, type T				
		type 1 A	type 2 A	type 1 A	type 2 A			
0.13 - 0.20	-	25	-	32	-	1	<b>047H3060</b>	TI 9C
0.19 - 0.29	-	25	-	32	2	1	<b>047H3061</b>	
0.27 - 0.42	-	25	2	32	2	1	<b>047H3062</b>	
0.4 - 0.62	-	25	2	32	4	1	<b>047H3063</b>	
0.6 - 0.92	-	25	4	32	6	3	<b>047H3064</b>	
0.85 - 1.3	-	25	4	32	6	3	<b>047H3065</b>	
1.2 - 1.9	-	25	6	32	10	6	<b>047H3066</b>	
1.8 - 2.8	3.2 - 4.8	25	6	32	10	15	<b>047H3067</b>	
2.7 - 4.2	4.7 - 7.3	25	16	32	20	15	<b>047H3068</b>	
4.0 - 6.2	6.9 - 10.7	35	20	40	25	15	<b>047H3069</b>	
6.0 - 9.2	10 - 16	50	20	50	25	35	<b>047H3070</b>	

<sup>1)</sup> To IEC 947-4 coordination types 1 and 2:

Coordination type 1: Any type of damage to the motor starter is permissible. If the motor starter is in an enclosure, no external damage to the enclosure is permissible. After a short-circuit the thermal overload relay shall be partially or wholly replaced.

Coordination type 2: No damage to the motor starter is permissible, but slight contact burning and welding is permissible.

<sup>2)</sup> In accordance with HRC form II, TI 9C is suitable for operation in Canada and the USA.

Selection of thermal overload relay

The selection of a thermal overload relay must be based on the motor full load current and the method of starting:

- With direct start the range for motor starter is used.
- With star-delta start the range for Y/Dstarter is used.

**Construction standards**

Contactors, thermal overload relays and accessories are designed and tested in accordance with IEC 947/EN 60947.

*Pulse voltage*

Type	U <sub>imp</sub>
CI 4-	8 kV

*Environment*

Temperate climate

Tested and passed in accordance with DIN 50 016 and 40 046 part 38 and IEC 68

Max. installation height: 2000 NN, in accordance with IEC 947

*Ambient temperature*

Type	Ambient temperature	
	Operation	Storage/Transport
CI 4-	-50°C ... +60°C	-55°C ... +80°C

*Vibration and shock*

Tested and passed in accordance with IEC 68-2-6

Type	Vibration <sup>1)</sup>	Chok <sup>2)</sup>
CI 4-	3g, 10-300 Hz	5 g, 12 ms

<sup>1)</sup> Operating conditions: All directions with de-energized coil.

<sup>2)</sup> Operating conditions: Parallel with armature and with de-energized coil

*Environment*

Type	Temperature compensated	Ambient temperature	Vibration	Shock perpendicular to contact system	Max. operations per hour
TI 9C	-5 to +40 °C	-50 to +60 °C	2 g at 200 Hz	9 g for 7.5 ms	30

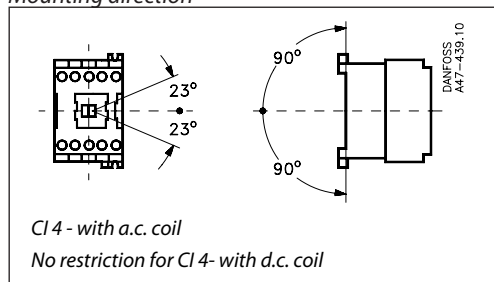
*Mounting direction*

**Rated life**

Type	Mechanical life AC-3 load Operations	Electrical life AC-3 load Operations	Switching per hour AC-3 load Operations
CI 4-	10 x 10 <sup>6</sup> <sup>1)</sup>	0.7 x 10 <sup>6</sup>	600

<sup>1)</sup> Direct current version: 20 million operations.

**Approvals**

Approval authority	CE	SP	UL			
Product type	EN 60947	UL-listed CSA, Canada	UL-listed USA	Lloyds Register of Shipping, UK	Germanischer Lloyd, Germany	Bureau Veritas France
CI 4-	●	●	●	●	●	●
TI 9C	●	● <sup>1)</sup>	● <sup>1)</sup>	●	□	□

● Approved  
□ Not applied for

<sup>1)</sup> c

Electrical life curve

Minicontactor CI 4-5, CI 4-9 and CI 4-12, load categories AC-1, AC-2 and AC-3

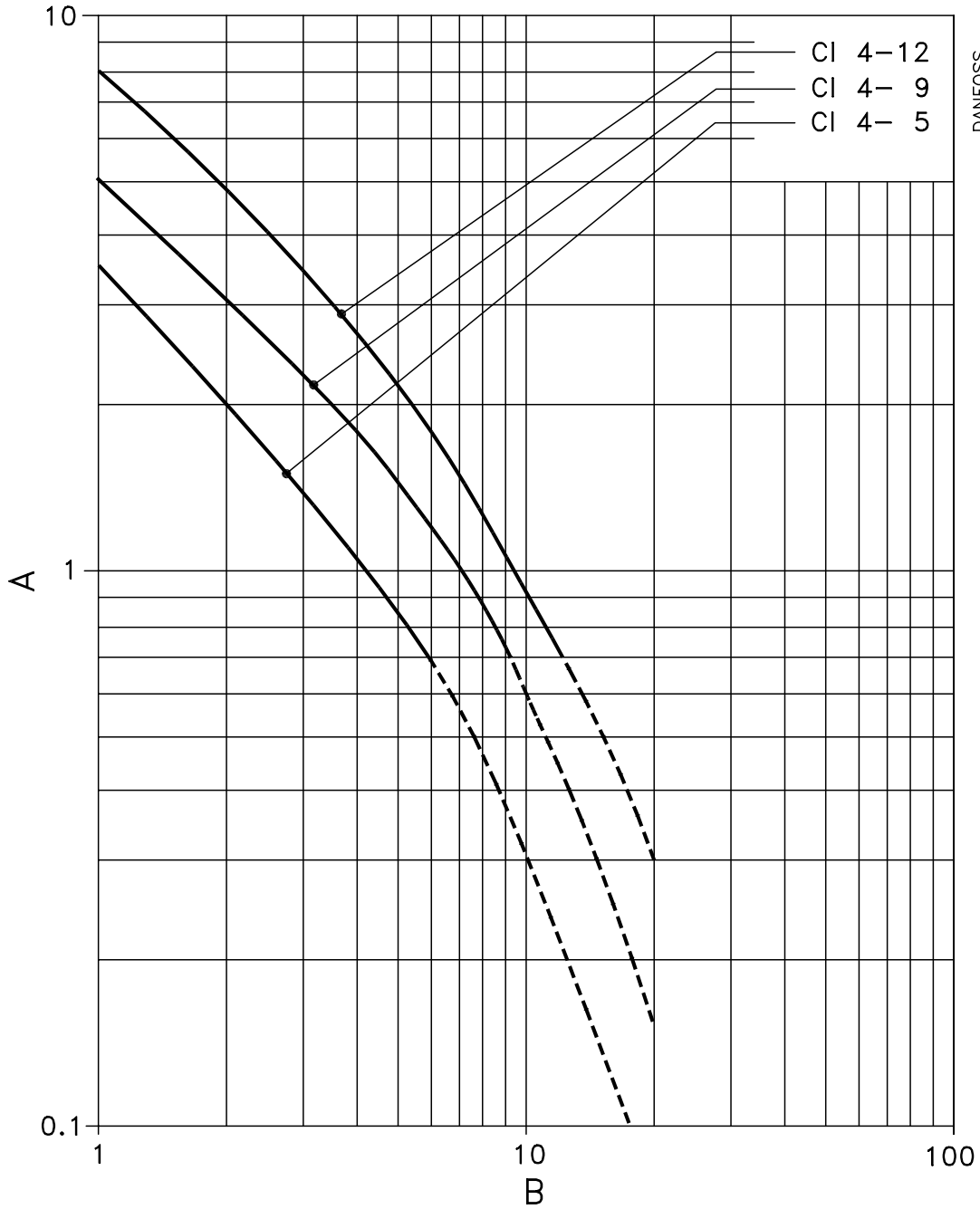

**A:** Electrical life in millions of make/break operations  
**B:** Breaking current (A)

Tripping graphs

TI 9C

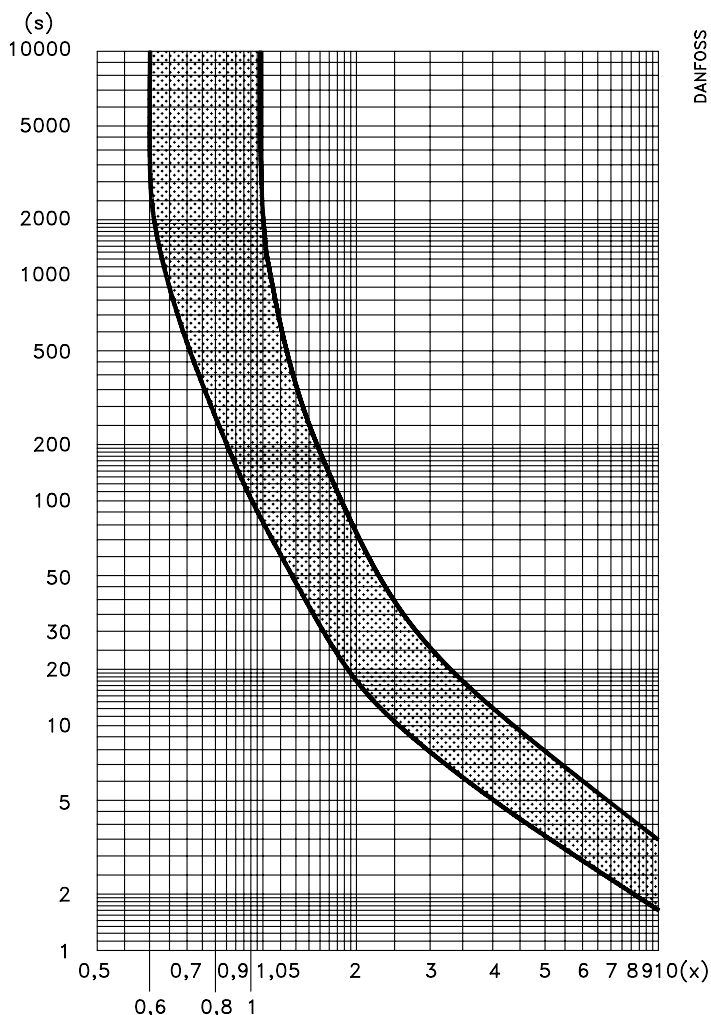

DANFOSS  
A47-392.12

3-phase overload

- 1) Measure overload current
- 2) Find the overload factor (x) by dividing the measured value by the set value of the thermal overload relay (motor full load current).
- 3) Find (x) on the horizontal axis and follow a line vertically up until it intersects the upper curve.
- 4) From the intersection point, follow a horizontal line to the left and read off on the vertical axis the time that will elapse before the thermal overload relay cuts out the motor.

Explanation of graphs

Mean value curves

Upper curve: 3-phase tripping and asymmetric load tripping at min. setting.

Lower curve: Asymmetric load tripping at max. setting.

When tripping from the operationally warm condition, the tripping times are approx. 30% of the values shown. These values apply at an ambient temperature = 20°C.

3-phase tripping:  $x = \frac{\text{measured current}}{\text{rated motor current}}$

Asymmetric load tripping:  $x = \frac{\text{measured current}}{\text{max. scale value on overload relay}}$

Tripping time  $2 < T_p < 10$  s at  $7.2 \times I_n$  class 10 A

Note! In general, the thermal overload relay is always set on motor full load current.

Asymmetric load tripping

- 1) Measure the current the motor draws from one of the intact phases.
- 2) Find the overload factor (x) by dividing the measured value by the maximum scale value of the thermal overload relay.
- 3) Find (x) on the horizontal axis and follow a line vertically up until it intersects the lower curve.
- 4) From the intersection point, follow a horizontal line to the left and read off on the vertical axis the time that will elapse before the thermal overload relay switch off the motor.

**Contact symbols and control relays terminal markings**

*Auxiliary contacts*

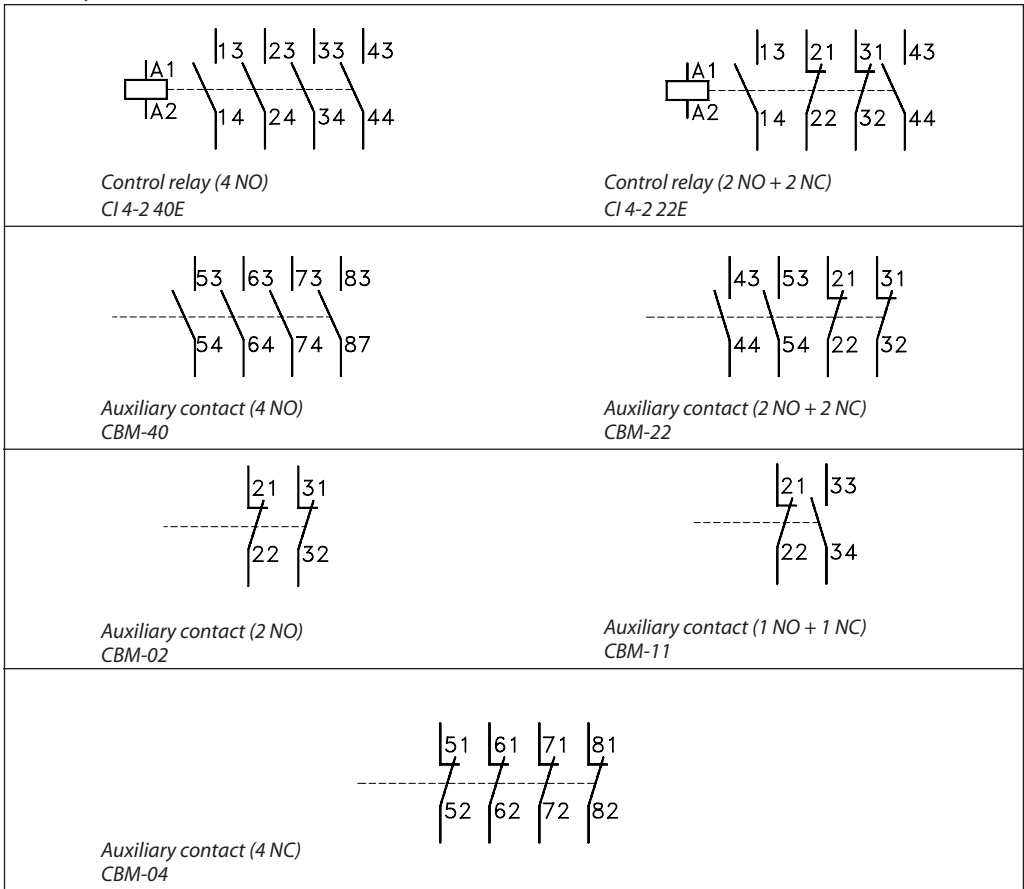

*Contactors*

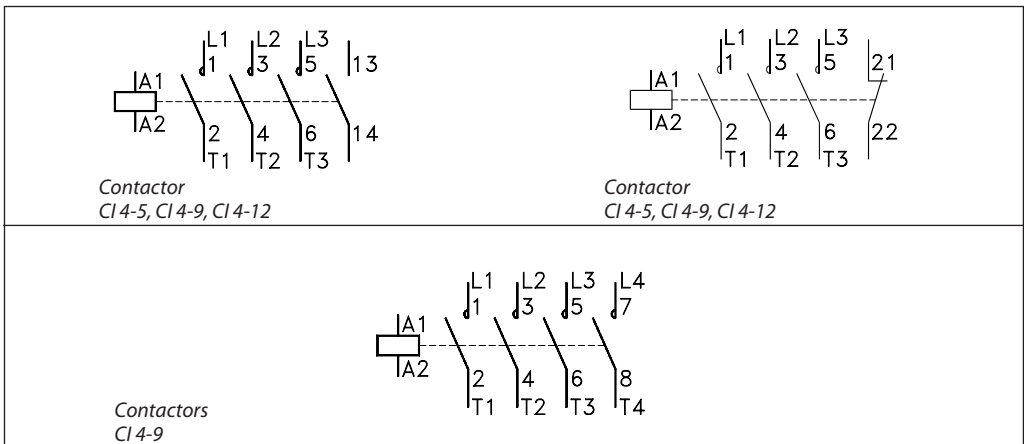

*Thermal overload relay*

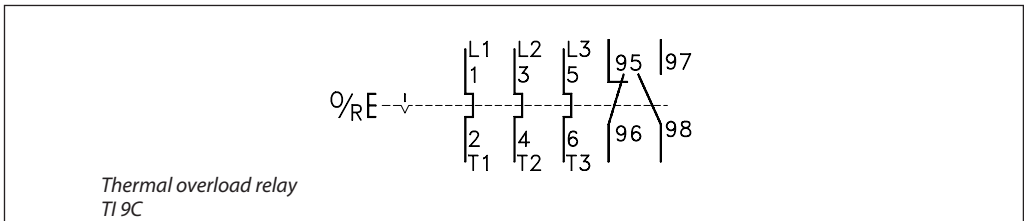



**Main circuit**
*Connections, main contacts*

Type	Connection method	EN 60947			Recommended Tightening torque [Nm]
		Single core [mm <sup>2</sup> ]	Multi core		
			without terminal sleeve [mm <sup>2</sup> ]	with terminal sleeve [mm <sup>2</sup> ]	
CI 4-	Screw and clamp washer	0.75 - 2.5	1-2.5	0.75-1.5	1-1.5
TI 9C	Screw and clamp washer	0.75 - 4	0.75 - 4	1 - 4	0.8 - 2

*Direct start, load categories AC-2, AC-3, AC-4*

Type		Rated loads at 50-60 Hz				
		220-230 V	240 V	380-400 V	415 V	500 V
CI 4-2	A	5.0	5.0	3.7	3.7	2.8
	kW	1.3	1.3	1.7	1.7	1.6
CI 4-5	A	6.5	6.0	5.3	4.8	4.0
	kW	1.5	1.5	2.2	2.2	2.2
CI 4-9	A	12.0	11.0	9.0	8.2	7.0
	kW	3.0	3.0	4.0	4.0	4.0
CI 4-12	A	12.0	12.0	12.0 <sup>1)</sup>	12.0 <sup>1)</sup>	7.0
	kW	3.3	3.4	5.9	6.1	4.2

<sup>1)</sup> Not AC-4

*Star-delta start, load category AC-3*

Type		Rated loads at 50-60 Hz				
		220-230 V	240 V	380-400 V	415 V	500 V
CI 4-9	A	15.0	14.0	16.0	14.0	12.0
	kW	4.0	4.0	7.5	7.5	7.5
CI 4-12	A	21.0	21.0	16.0	16.0	12.0
	kW	5.8	6.3	10.8	11.2	7.7

*Three phase ohmic load, load category AC-1*

Type		Operating temperature max 40°C (Open condition)				
		220-230 V	240 V	380-400 V	415 V	500 V
CI 4-2	A	16.0	16.0	16.0	16.0	16.0
	kW	6.0	6.0	10.0	11.0	13.0
CI 4-5/CI 4-9	A	20.0	20.0	20.0	20.0	20.0
CI 4-12	kW	8.0	8.3	14.0	14.0	17.0

*Three phase ohmic load, load category AC-1*

Type		Operating temperature max 60°C (Enclosed condition)				
		220-230 V	240 V	380-400 V	415 V	500 V
CI 4-2	A	12.0	12.0	12.0	12.0	12.0
	kW	4.5	5.0	7.0	8.0	9.0
CI 4-5/CI 4-9	A	16.0	16.0	16.0	16.0	16.0
CI 4-12	kW	6.4	6.7	11.0	12.0	14.0

*Switching lighting*

Type	Incandescent lamps		Fluorescent lamps, individually compensated			
	Max. operating current		Max. operating current [A] at operating temp. <sup>1)</sup>		Max. capacitor [μF] at I <sub>CC</sub> =	
	A		40 °C	60 °C	10 kA	20 kA
CI 4-2, -5, -9, -12	9.3		18	14.5	750	400

<sup>1)</sup> 40 °C is defined as non-enclosed condition  
 60 °C is defined as enclosed condition

*Short time withstand current I<sub>cw</sub>*

Type	Current transfer time in sec.							Min. cooling in min.
	1	4	10	15	60	240	900	
	Short time withstand current in Amps (I <sub>cw</sub> )							
CI 4-5, CI 4-9	110	85	60	50	30	20	20	3
CI 4-12	144	113	96	78	40	20	20	3

**Main circuit**
*Switching direct current load*

Load categories DC-3 and DC-5, contacts connected in series

Type	Max. operating current [A]								
	DC-3, 3 pole in series					DC-5, 3 pole in series			
	24 V	48 V	110 V	220 V	440 V	24 V	48 V	110 V	220 V
CI 4-5	5	4	2	0.8	0.15	5	2	0.6	0.1
CI 4-9	9	6	3	1.2	0.2	9	3	1	0.1
CI 4-12	9	6	3	1.2	0.2	9	3	1	0.1

<sup>1)</sup> 40 °C is defined as non-enclosed condition  
 60 °C is defined as enclosed condition

*Switching direct current load*

Load categories DC-1, contacts connected in series

Type	Max. operating current [A]														
	24 V			48 V			110 V			220 V			440 V		
	1-pole	2-pole	3-pole	1-pole	2-pole	3-pole	1-pole	2-pole	3-pole	1-pole	2-pole	3-pole	1-pole	2-pole	3-pole
CI 4-5	6	6	6	4	6	6	0.6	4	6	0.2	0.8	3	0.08	0.2	0.4
CI 4-9/CI 4-12	9	9	9	6	8	9	1	6	9	0.3	1.2	4	0.1	0.3	0.6

**Power loss**
*Contact resistance and power losses*

Type	Typical impedance per pole mΩ	Power losses all 3 poles		Coil consumption a.c. W	Total power losses	
		AC-3 W	AC-1 W		AC-3 W	AC-1 W
		CI 4-2	5.5		0.25	4.2
CI 4-5	5.5	0.4	6.6	1.4	1.8	8.0
CI 4-9	5.5	1.3	6.6	1.4	2.7	8.0
CI 4-12	5.5	2.4	6.6	1.4	3.8	8.0

Type	Average power	
	Min. setting	Max. setting
TI 9C	typically 2.15 W	typically 4.87 W

**Control circuit**
*Connections, auxiliary contacts*

Type/Application	Connection method	Single core [mm <sup>2</sup> ]	Multi core		Tightening torque [Nm]
			without terminal sleeve [mm <sup>2</sup> ]	with terminal sleeve [mm <sup>2</sup> ]	
CI 4- built in	Screw and clamp washer	0.75 - 2.5	1 - 2.5	0.75 - 1.5	1 - 1.5
CBM for CI 4-	Screw and clamp washer	0.75 - 2.5	1 - 2.5	0.75 - 1.5	1 - 1.5
TI 9C	Screw and clamp washer	0.75 - 2.5	0.75 - 1.5	0.75 - 1.5	0.78 - 1

*Auxiliary contacts, load categories AC-15 and AC-1*

Type	Comments	Max. operating current [A]						
		AC-15					AC-1	
		220-230 V	240 V	400 V	415 V	500 V	40 °C <sup>1)</sup>	60 °C <sup>1)</sup>
CI 4-	Built into contactor	6	5	2.5	2	1.25	16	12
CBM	For contactor CI 4-	2	2	1	1	0.6	10	6

<sup>1)</sup> 40 °C is defined as non-enclosed condition  
60 °C is defined as enclosed condition

*Auxiliary contacts, load categories DC-12, DC-13, DC-14*

Type	Comments	Max. operating current [A]														
		DC-12					DC-13					DC-14				
		24 V	48 V	110 V	220 V	440 V	24 V	48 V	110 V	220 V	440 V	24 V	48 V	110 V	220 V	440 V
CI 4-	Built into contact.	6	4	0.6	0.2	0.08	5	0.6	0.45	0.25	0.04	4	2.5	0.4	0.12	0.05
CBM	For contact. CI 4-	6	2	0.6	0.2	0.08	2	0.6	0.45	0.1	0.04	4	1.2	0.4	0.12	0.05

*Coil consumption and operating times*

Type	Inrush power			Holding power			Pull-in voltage		Drop-out voltage		Make time		Break time	
	a.c.		d.c.	a.c.		d.c.	a.c.	d.c.	a.c.	d.c.	a.c.	d.c.	a.c.	d.c.
	VA	W	W	VA	W	W	V	V	V	V	ms	ms	ms	ms
CI 4-	22	20	2.5	4	1.4	2.5	$(0.85-1.1) \times U_s$	$(0.85-1.1) \times U_s$	$(0.35-0.65) \times U_s$	$(0.1-0.25) \times U_s$	15-40	18-40	15-25	6-12

*RC Element (charge suppressor)*

Type	Comments	Overvoltage factor $n = \frac{U_{max}}{U_n}$
RCM	Suitable for contactors CI 4	1-2.5

*Max. load control circuit (contact system)*

Type	Load		Max fuse	
	AC-15	DC-13	gl, gL, gG	BS 88 type T
TI 9C	500 V 2 A 200 VA	250 V 2 A 20 W	4 A	6 A

**UL/CSA specifications**
*UL/CSA approved loads*

Type	Motor load (AC-3) [hp]							Other loads (AC-1) [A]			
	1-phase		3-phase					UL		CSA	
	115 V	230 V	115 V	200 V	240 V	460 V	575 V	40 °C <sup>1)</sup>	60 °C <sup>1)</sup>	40 °C <sup>1)</sup>	60 °C <sup>1)</sup>
CI 4-5	0.5	1	1	1.5	1.5	3	3	12	12	12	12
CI 4-9	0.5	1.5	2	2	2	5	5	12	12	12	12
CI 4-12	0.5	2	3	3	3	7.5	10	12	12	12	12

<sup>1)</sup> 40 °C is defined as non-enclosed condition  
60 °C is defined as enclosed condition

*Auxiliary contacts, UL/CSA approved loads*

Type	Comments	Load capacity			
		c.a.		d.c.	
		Category	VA	Category	W
CI 4-	Built into contactor	A600	720	Q600	69
CBM	For contactor CI 4-	A600	720	Q600	69

Dimensions

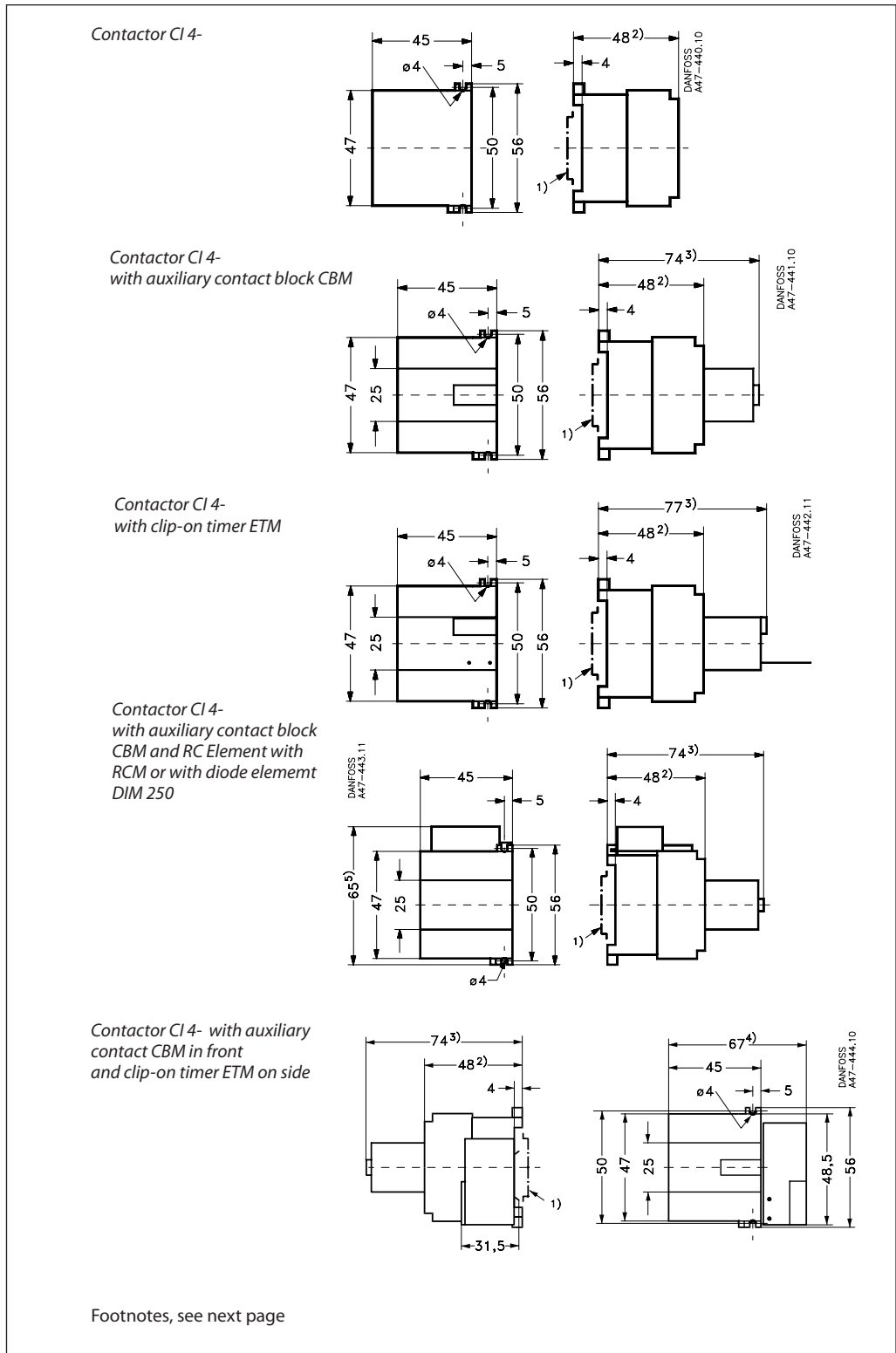

**Dimensions  
Accessories**

*Motor starter CI 4 + TI 9C*

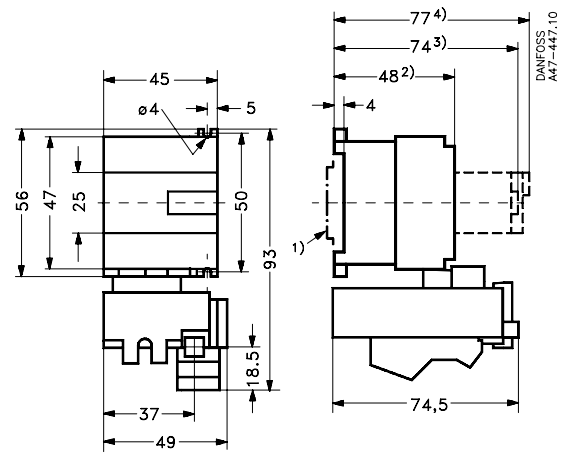

*RC element, type RCM  
Diode element DIM*

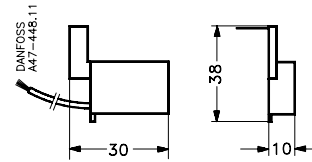

*Clip-on timer ETM  
with adapter on DIN rail  
EN 60715-35*

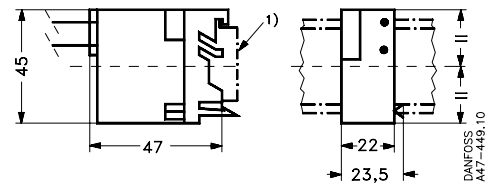

*Clip-on timer ETM  
with adapter on DIN rail*

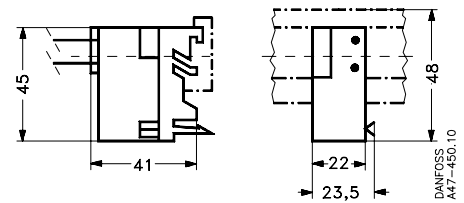

- 1) Fixing possibilities on DIN rail DIN EN 60715-35
- 2) Basic unit without accessories
- 3) With auxiliary contact block CBM
- 4) With Clip-on timer ETM
- 5) With RC Element RCM or diode element DIM

Danfoss can accept no responsibility for possible errors in catalogues, brochures and other printed material. Danfoss reserves the right to alter its products without notice. This also applies to products already on order provided that such alterations can be made without subsequential changes being necessary in specifications already agreed. All trademarks in this material are property of the respective companies. Danfoss and the Danfoss logotype are trademarks of Danfoss A/S. All rights reserved.