

Data sheet

Oil Preheaters Types FPHE 3, 5 and 10

Application

FPHE oil preheaters are designed for oil burners with capacity up to 12 kg/h using standard fuel oil with viscosity up to 10 cSt.

The preheaters are available with different heating elements and thermostats for selection of release time and temperature.

Features:

- Standard types of gasoil with viscosity of max. 10 cSt. (at 20°C)
- Capacity up to 12 kg/h
- Max. temperature limitation
- Improved atomisation
- High average efficiency of the burner

Identification

The preheater is laser engraved with the following information (example):

FPHE 5	Type
030N5004	Code no.
230 V	Voltage
30-110 W	Power consumption
130805	Date of manufacture

Function

Cold start

When the boiler thermostat cuts-in, voltage is applied to the PTC heating element and the oil in the heat exchanger is heated until it reaches the cut-in temperature of the preheater thermostat (see below table). Now the burner performs a normal starting sequence.

Warm start

If the oil temperature in the preheater is higher than the cut-out temperature of the preheater thermostat, the burner starts immediately.

Operation

If the oil temperature is low and the flow rate is high, compared with the preheater capacity, the preheater thermostat might cut off during operation. To avoid this an oil burner control with holding function must be used.

Release times and temperatures

Type	PTC	Thermostat 60/32 & 60/45		Thermostat 73/60	
		Release time, seconds	Release temp. in outlet, °C	Release time, seconds	Release temp. in outlet, °C
FPHE 3	40	80	22	-	-
FPHE 5	50	130	36	-	-
	70	75	26	130	43
	120	50	22	80	32
FPHE 10	2 x 50	120	44	-	-
	2 x 70	110	41	150	60
	2 x 120	65	39	85	49

The figures given are measured average values on cold start and without blown air. Note that the PTC element continues to heat during prepurge.

Technical Data

	FPHE 3	FPHE 5	FPHE 10
Oil types	Standard fuel gas oil and fuel gas oil acc. to DIN 51603-6 EL A (bio content, FAME)		
Nominal voltage*	230 V, 50-60 Hz		
Contact load, thermostat	10 (3) A - 250 V		
Max. permissible pressure	30 bar		
Capacity	max. 3 kg/h	max. 6 kg/h	max. 12 kg/h
Max. ambient temperature	105°C		
Storage temperature	-20 to 105°C		
Max. pressure drop	0.03 bar at 3 kg/h	0.05 bar at 5 kg/h	0.25 bar at 10 kg/h
Recommended tightening torque	15 to 20 Nm		
Viscosity	max. 10 cSt. at 20°C		

* Working voltage: 100 to 265 V, 50-60 Hz

Temperature / capacity

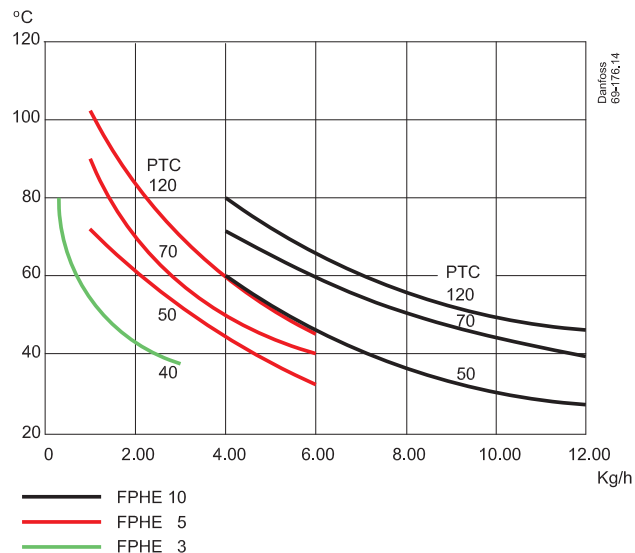

Power consumption / capacity

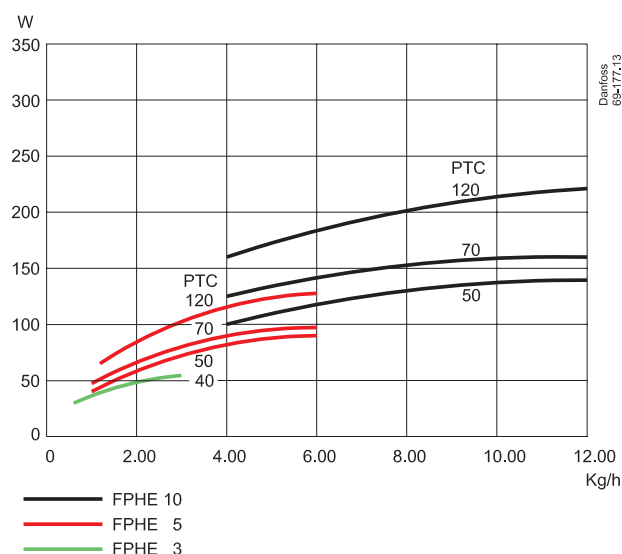

Design

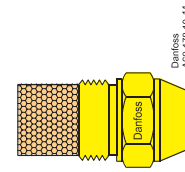
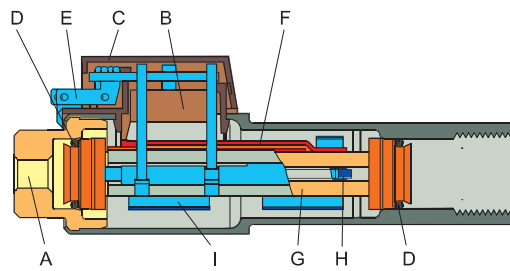

- A. Connection port
- B. Thermostat
- C. Cover
- D. O-ring
- E. Electrical connection
- F. Heat conductor (not FPHE 3)
- G. Heat exchanger
- H. PTC element
- I. Clamp

Electrical Connection

- 4 = Black
- 3 = Blue
- 2 = Brown
- 1 = Yellow / Green

OTR: Thermostat in oil preheater

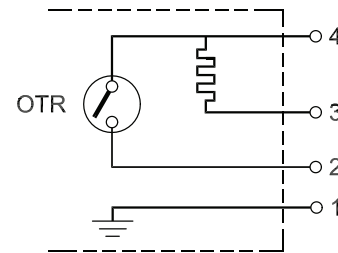

Dimensions

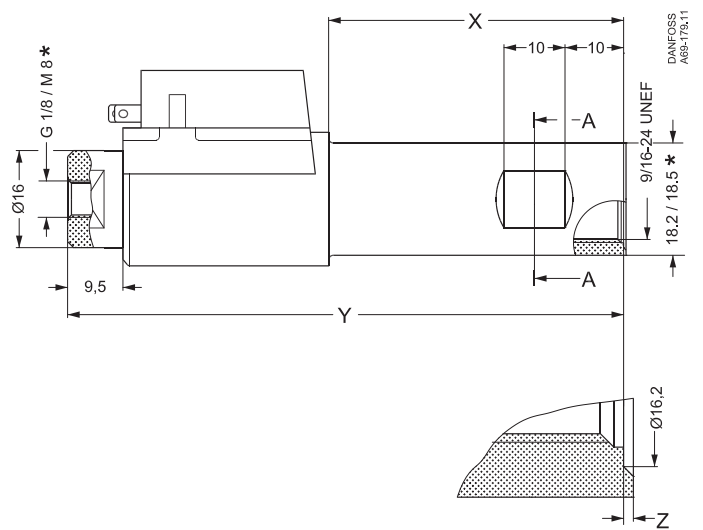
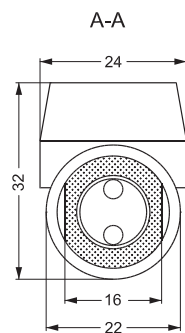

Type	X	Y	Z
FPHE 3	50	92	0.3
FPHE 5	50	92	0.3
FPHE 10*	88	131	-

* FPHE 10 has no recessed sealing surface.



Additional documentation on burner components is available on <http://heating.danfoss.com/>

Danfoss A/S

Heating Segment • heating.danfoss.com • +45 7488 2222 • E-Mail: heating@danfoss.com

Danfoss can accept no responsibility for possible errors in catalogues, brochures and other printed material. Danfoss reserves the right to alter its products without notice. This also applies to products already on order provided that such alterations can be made without subsequential changes being necessary in specifications already agreed. All trademarks in this material are property of the respective companies. Danfoss and all Danfoss logotypes are trademarks of Danfoss A/S. All rights reserved.
