

# BOCK® HG12P (HC/LG)

## Operating guide

HG(X)12P/60-4 S  
HG(X)12P/75-4 (S)  
HG(X)12P/90-4 (S)  
HG(X)12P/110-4 (S)

HGX12P/75 ML 1 LG  
HGX12P/90 ML 2 LG  
HGX12P/110 ML 2 LG

HG12P/60-4 S HC  
HG12P/75-4 (S) HC  
HG12P/90-4 (S) HC  
HG12P/110-4 (S) HC

HGX12P/60 S 0,7 LG  
HGX12P/75 S 1 LG  
HGX12P/90 S 2 LG  
HGX12P/110 S 3 LG

# About these instructions

Read these instructions before assembly and before using the compressor. This will avoid misunderstandings and prevent damage. Improper assembly and use of the compressor can result in serious or fatal injury.

Observe the safety instructions contained in these instructions.

These instructions must be passed onto the end customer along with the unit in which the compressor is installed.

## Contents

Page

<b>1</b>	<b>Safety</b>	<b>4</b>
1.1	Identification of safety instructions	
1.2	Qualifications required of personnel	
1.3	General safety instructions	
1.4	Intended use	
<b>2</b>	<b>Safety instructions for use of flammable refrigerants</b>	<b>6</b>
2.1	Safety instructions	
2.2	Qualifications required of personnel	
<b>3</b>	<b>Product description</b>	<b>7</b>
3.1	Short description	
3.2	Name plate	
3.3	Type key	
3.4	Type key HC compressors	
3.5	Type key LG compressors	
<b>4</b>	<b>Areas of application</b>	<b>10</b>
4.1	Refrigerants	
4.2	Oil charge	
4.3	Limits of application	
<b>5</b>	<b>Areas of application on HC and LG compressors</b>	<b>11</b>
5.1	Refrigerants	
5.2	Oil charge	
5.3	Limits of application	
<b>6</b>	<b>Compressor assembly</b>	<b>12</b>
6.1	Storage and transport	
6.2	Setting up	
6.3	Pipe connections	
6.4	Pipes	
6.5	Laying suction and pressure lines	
6.6	Suction pipe filter and filter drier	
6.7	Operating the shut-off valves	
6.8	Operating mode of the lockable service connections	

GB

<b>7</b>	<b>Electrical connection</b>	<b>15</b>
7.1	Information for contactor and motor contactor selection	
7.2	Connection of the driving motor	
7.3	Circuit diagram for direct start 230 V $\Delta$ / 400 V Y	
7.4	Electronic trigger unit INT69 G	
7.5	Connection of the electronic trigger unit INT69 G	
7.6	Functional test of the electronic trigger unit INT69 G	
7.7	Electronic trigger unit INT69 G on HC and LG compressors	
7.8	Oil sump heater on HC and LG compressors	
7.9	Selection and operation of compressors with frequency converters	
<b>8</b>	<b>Commissioning</b>	<b>21</b>
8.1	Preparations for start-up	
8.2	Pressure strength test	
8.3	Leak test	
8.4	Evacuation	
8.5	Refrigerant charge	
8.6	Start-up	
8.7	Avoiding slugging	
8.8	Connection of oil level regulator	
<b>9</b>	<b>Maintenance</b>	<b>23</b>
9.1	Preparation	
9.2	Work to be carried out	
9.3	Spare parts recommendation/accessories	
9.4	Lubricants / oil	
9.5	Decommissioning	
9.6	Additional information when using flammable refrigerants	
<b>10</b>	<b>Technical data</b>	<b>25</b>
<b>11</b>	<b>Dimensions and connections</b>	<b>26</b>
<b>12</b>	<b>Declaration of incorporation</b>	<b>27</b>

# 1| Safety

## 1.1 Identification of safety instructions:



**DANGER**

Indicates a dangerous situation which, if not avoided, will cause immediate fatal or serious injury.



**WARNING**

Indicates a dangerous situation which, if not avoided, may cause fatal or serious injury.



**CAUTION**

Indicates a dangerous situation which, if not avoided, may cause fairly severe or minor injury.



**ATTENTION**

Indicates a situation which, if not avoided, may cause property damage.



**INFO**

Important information or tips on simplifying work.

GB

## 1.2 Qualifications required of personnel



**WARNING**

**Inadequately qualified personnel poses the risk of accidents, the consequence being serious or fatal injury. Work on compressors is therefore reserved for personnel which is qualified to work on pressurized refrigerant systems:**

- For example, a refrigeration technician, refrigeration mechatronic engineer. As well as professions with comparable training, which enables personnel to assemble, install, maintain and repair refrigeration and air-conditioning systems. Personnel must be capable of assessing the work to be carried out and recognising any potential dangers.

# 1 | Safety

## 1.3 General safety instructions



### WARNING

**Risk of accidents.**

**Refrigerating compressors are pressurised machines and as such call for heightened caution and care in handling.**

**The maximum permissible overpressure must not be exceeded, even for testing purposes.**

**Risk of burns!**

**- Depending on the operating conditions, surface temperatures of over 60 °C on the discharge side or below 0 °C on the suction side can be reached.**

**- Avoid contact with refrigerant necessarily.**

**Contact with refrigerant can cause severe burns and skin damage.**

## 1.4 Intended use



### WARNING

**The compressor may not be used in potentially explosive environments!**

GB

These assembly instructions describe the standard version of the compressor named in the title manufactured by Bock. Bock refrigerating compressors are intended for installation in a machine (within the EU according to the EU Directives 2006/42/EC Machinery Directive and 2014/68/EU Pressure Equipment Directive).

Commissioning is permissible only if the compressor has been installed in accordance with these assembly instructions and the entire system into which it is integrated has been inspected and approved in accordance with legal regulations.

The compressors are intended for use in refrigeration systems in compliance with the limits of application.

Only the refrigerant specified in these instructions may be used.

**Any other use of the compressor is prohibited!**

## 2 | Safety instructions for use of flammable refrigerants

### 2.1 Safety instructions



#### DANGER

- **Explosion and fire risk!** Hydrocarbons and synthetic HFO refrigerants are colourless, combustible gases which occur naturally and which are explosive in a certain blend!



- Hydrocarbons are classified into the safety group A3 (highly-flammable refrigerant) according to EN 378.
- HFO refrigerants are classified into the safety group A2L (hardly-flammable refrigerant) according to EN 378.

As they are heavier than air, the operating location must be above ground level to allow unrestricted discharge of the gas.

- By means of a risk and hazard analysis, appropriate technical measures are to be identified in order to achieve sufficient risk reduction. If necessary, a classification of the hazardous areas according to EN60079-10-1 should be carried out. If the refrigerant concentration exceeds the value of 25% of the lower flammability limit (LEL), all equipment in the hazardous area which is not permitted for operation in hazardous areas must be immediately switched off without any voltage.
- Use only suitable equipment approved for flammable refrigerants.
- Observe the national regulations.



#### INFO

Semi-hermetic compressors are to be classified as "technically tight" (see e.g. TRBS 2152 part 2 / TRGS 722).

### 2.2 Qualifications required of personnel



#### WARNING

Inadequately qualified personnel poses the risk of accidents, the consequence being serious or fatal injury. Work on the compressor may therefore only be carried out by persons who are trained in handling flammable refrigerants.

# 3| Product description

## 3.1 Short description

- Semi-hermetic two-cylinder reciprocating compressor with oil pump lubrication.
- Suction gas cooled drive motor.

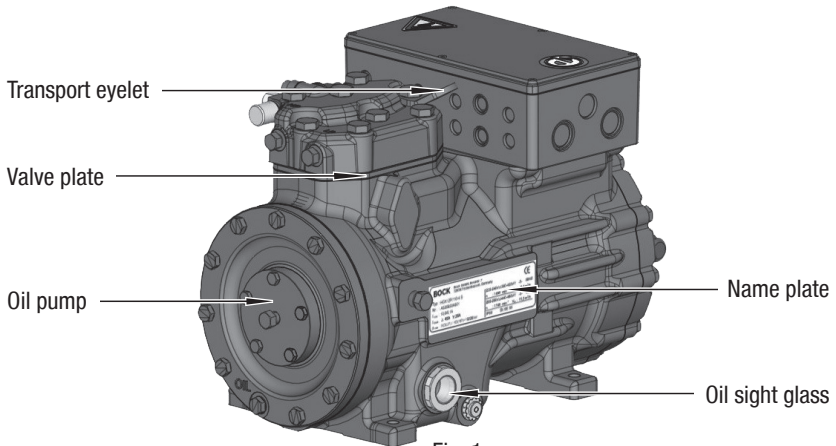

Fig. 1

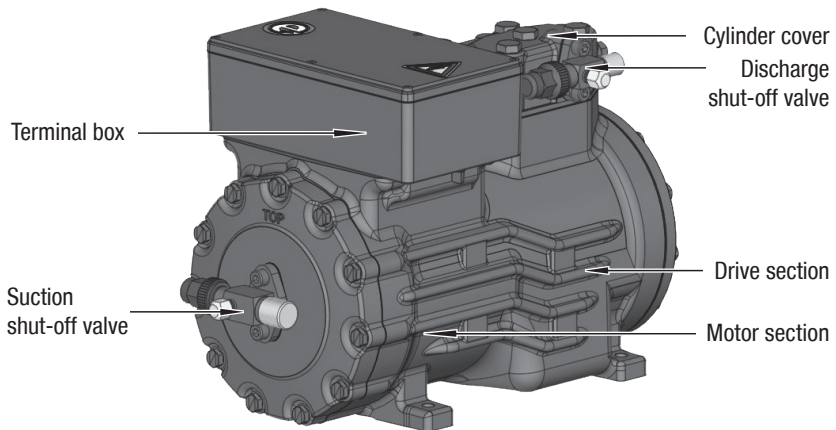

Fig. 2

Dimension and connection values can be found in Chapter 11

GB

# 3| Product description

## 3.2 Name plate (example)

<b>BOCK</b> Bock GmbH, Benzstr. 7 72636 Frickenhausen, Germany		<b>CE</b>
1 Typ : HGX12P/110-4S	220-240VΔ/380-420VY -3- 50HZ	6
2 Nr. : AS35830A001	n : 1450 min <sup>-1</sup> V <sub>th.</sub> : 9,4 m <sup>3</sup> /h	7
3 I <sub>max</sub> : 10,6/6,1A	265-290VΔ/440-480VY -3- 60HZ	8
4 I <sub>block.</sub> Δ: 45A Y: 26A	n : 1740 min <sup>-1</sup> V <sub>th.</sub> : 11,3 m <sup>3</sup> /h	9
5 p <sub>max</sub> : ND(LP) / HD(HP)=19/28 bar	IP65 Öl: BOCK lub E55	10
		11
		12
		13

Fig. 3

1 Type designation	6 Voltage, circuit, frequency
2 Machine number	7 Nominal rotation speed } 50 Hz
3 maximum operating current	8 Displacement
4 Starting current (rotor blocked)	9 Voltage, circuit, frequency
5 ND (LP): max. admissible operating pressure (g) Low pressure side	10 Nominal rotation speed } 60 Hz
HD (HP): max. admissible operating pressure (g) High pressure side	11 Displacement
	12 Oil type filled at the factory
	13 Terminal box protection type



**Observe the limits of application diagrams!**



**Electrical accessories can change the IP protection class!**

GB

## 3.3 Type key (example)

**HG X 12 P / 110-4 S**

- Motor variant <sup>4)</sup>
- Number of poles
- Swept volume
- pluscom** <sup>3)</sup>
- Numbers of cylinders
- Size
- Oil charge <sup>2)</sup>
- Series <sup>1)</sup>

- 1) HG - Hermetic Gas-cooled (suction gas-cooled) for the normal- / air conditioning applications
- 2) X - Ester oil charge (HFC refrigerant, e.g. R134a, R404A/R507, R407C)
- 3) Additional declaration for Pluscom compressors
- 4) S - More powerful motor, e.g. for air-conditioning applications

## 3| Product description

### 3.4 Type key HC compressor (example)

**HG 12 P / 110-4 S HC**

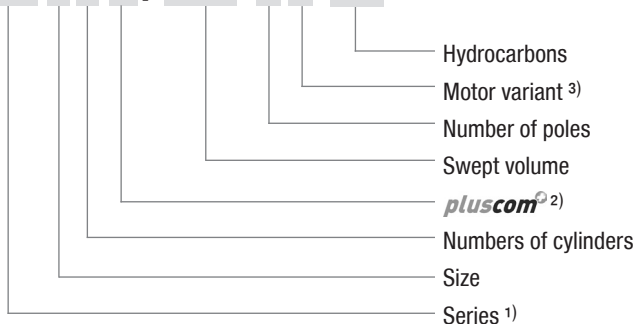

- 1) HG - Hermetic Gas-Cooled (suction gas-cooled)
- 2) Additional declaration for Pluscom compressors
- 3) S - More powerful motor

### 3.5 Typ key LG compressor (example)

**HG X 12 P / 110 S 3 LG**

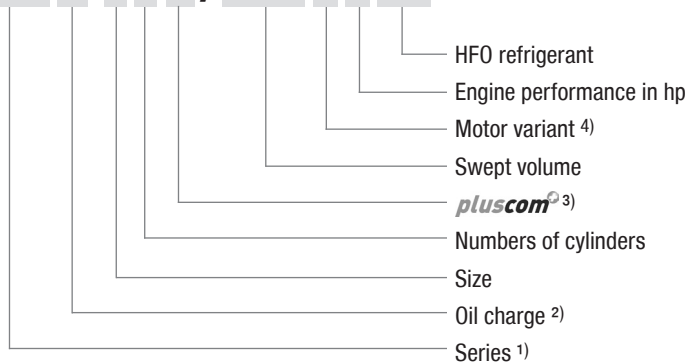

- 1) HG - Hermetic Gas-Cooled (suction gas-cooled)
- 2) X - Ester oil charge
- 3) Additional declaration for Pluscom compressors
- 4) S - More powerful motor, e.g. for air-conditioning applications  
ML - Motor for normal cooling and deep freezing

GB

## 4| Areas of application

### 4.1 Refrigerants

- HFKW / HFC: R134a, R404A/R507, R407C
- (H)FCKW / (H)CFC: R22

### 4.2 Oil charge

- The compressors are filled at the factory with the following oil type:
  - for R404A/R507 **BOCK**lub E55
  - for R22 **BOCK**lub A46

Compressors with ester oil charge (**BOCK**lub E55) are marked with an X in the type designation (e.g. HGX12P/110-4).



#### INFO

For refilling, we recommend the above oil types.  
Alternatives: see chapter 9.4



#### ATTENTION

The oil level must be in the visible part of the sight glass; damage to the compressor is possible if overfilled or underfilled!

max.

oil level

min.

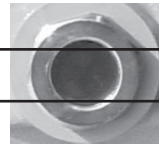

≈ 0,5 Ltr.

Fig. 4

GB

### 4.3 Limits of application



#### ATTENTION

Compressor operation is possible within the operating limits. These can be found in Bock compressor selection tool (VAP) under [vap.bock.de](http://vap.bock.de). Observe the information given there.

- Permissible ambient temperature (-20 °C) - (+60 °C).
- Max. permissible discharge end temperature 140 °C.
- Max. permissible switching frequency 8x / h.
- A minimum running time of 3 min. steady-state condition (continuous operation) must be achieved.

For operation with supplementary cooling:

- Use only oils with high thermal stability.
- Avoid continuous operation near the threshold.

For operation with frequency converter (see also chapter 7.9):

- The maximum current and power consumption must not be exceeded. In the case of operation above the mains frequency, the application limit can therefore be limited.

When operating in the vacuum range, there is a danger of air entering on the suction side. This can cause chemical reactions, a pressure rise in the condenser and an elevated compressed-gas temperature. Prevent the ingress of air at all costs!

Max. permissible operating pressure (LP/HP)<sup>1)</sup>: 19/28 bar

<sup>1)</sup> LP = low pressure HP = high pressure

# 5 | Areas of application at HC and LG compressors

## 5.1 Refrigerants

- Hydrocarbons: R290, R1270 (Recommendation quality 2.5 (< 50 ppm H<sub>2</sub>O))
- HFO refrigerants: R1234ze, R1234yf, R455A, R454C

## 5.2 Oil charge

The compressors are factory-charged with the following oil type:

- HC compressors: **BOCK**lub G68
- LG compressors: **BOCK**lub E55  
**BOCK**lub E85 (from  $t_0 > 15^\circ\text{C}$ , must be specified in the order)

## 5.3 Operating limits



**ATTENTION** Compressor operation is possible within the operating limits. These can be found in Bock compressor selection tool (VAP) under [vap.bock.de](http://vap.bock.de). Observe the information given there and the following notes:

- Minimum superheating  $\Delta t_{\text{oh}} = 20 \text{ K}$  (only at HC compressors)

In order to guarantee the required minimum superheating of  $\Delta t_{\text{oh}} = 20 \text{ K}$ , an internal heat exchanger IHX may have to be installed. (only at HC compressors)

- Min. pressure gas temperature  $\geq 50^\circ\text{C}$  (min. 20K over condensing temperature). Suction gas superheating on compressor entrance should be min. 7 - 10 K, must be increased if necessary (only at LG compressors)
- Min. oil temperature  $\geq 30^\circ\text{C}$ .
- Operation in the vacuum range is not permitted.
- When using a additional fan, the ambient temperature must not exceed  $50^\circ\text{C}$ .

During operation in the vacuum range, there is a danger of air entering on the suction side. This can cause chemical reactions, pressure rise in the condenser and an excessive pressure gas temperature as well as shifting of the refrigerant ignition limit into the critical range. Avoid absolutely any entry of air!

Use a low pressure switch! Select a shut-off point min. 50 Pa higher than the prevailing surrounding pressure!

Maximum permissible operating pressure (LP/HP)<sup>1)</sup>: 19/28 bar

<sup>1)</sup> LP = Low pressure HP = High pressure

GB

## 6| Compressor assembly



### INFO

New compressors are factory-filled with inert gas. Leave this service charge in the compressor for as long as possible and prevent the ingress of air. Check the compressor for transport damage before starting any work.

### 6.1 Storage and transport



- Storage at (-30 °C) - (+70 °C), maximum permissible relative humidity 10 % - 95 %, no condensation
- Do not store in a corrosive, dusty, vaporous atmosphere or in a combustible environment.
- Use transport eyelet.
- Do not lift manually!
- Use lifting gear!

### 6.2 Setting up



**ATTENTION** Attachments (e.g. pipe holders, additional units, fastening parts, etc.) directly to the compressor are not permissible!

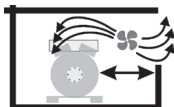

- Provide adequate clearance for maintenance work.
- Ensure adequate compressor ventilation.



- Do not use in a corrosive, dusty, damp atmosphere or a combustible environment.

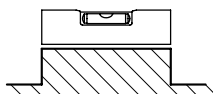

- Setup on an even surface or frame with sufficient load-bearing capacity.
- Single compressor preferably on vibration damper.
- Duplex and parallel circuits always rigid.



- Sun protection: If the compressor is set up outdoors, it has to be protected from direct sunlight.

### 6.3 Pipe connections



**ATTENTION** Damage possible.  
Do not solder as long as the compressor is under pressure. Superheating can damage the valve. Remove the pipe supports therefore from the valve for soldering and accordingly cool the valve body during and after soldering.  
Only solder using inert gas to inhibit oxidation products (scale).

## 6| Compressor assembly

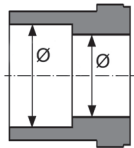

Fig. 5: graduated internal diameter

- The **pipe connections** have graduated inside diameters so that pipes with standart millimetre and inch dimensions can be used.
- The connection diameters of the shut-off valves are rated for maximum compressor output. **The actual required pipe cross section must be matched to the output. The same applies for non-return valves.**

### 6.4 Pipes

- Pipes and system components must be clean and dry inside and free of scale, swarf and layers of rust and phosphate. Only use air-tight parts.
- Lay pipes correctly. Suitable vibration compensators must be provided to prevent pipes being cracked and broken by severe vibrations.
- Ensure a proper oil return.
- Keep pressure losses to an absolute minimum.

### 6.5 Laying suction and pressure lines



**ATTENTION** Improperly installed pipes can cause cracks and tears, the result being a loss of refrigerant.



**INFO** Proper layout of the suction and discharge lines directly after the compressor is integral to the system's smooth running and vibration behaviour.

GB

**A rule of thumb:** Always lay the first pipe section starting from the shut-off valve **downwards and parallel to the drive shaft**.

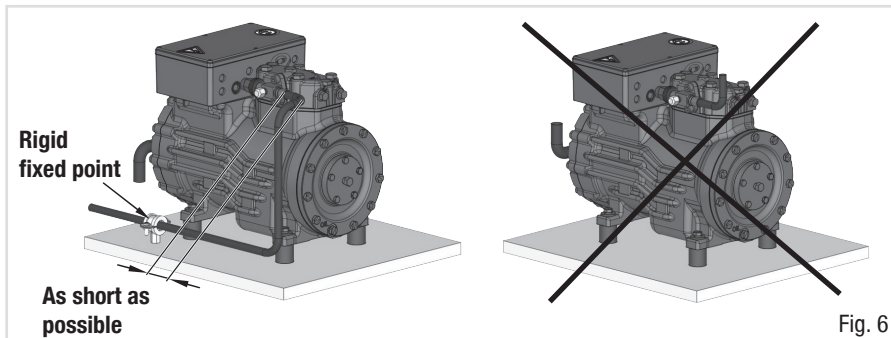

Fig. 6

### 6.6 Suction pipe filter and filter drier

For systems with long pipes and higher degree of contamination, a filter on the suction-side is recommended. The filter has to be renewed depending on the degree of contamination (reduced pressure loss).

Moisture in the refrigeration circuit can lead to crystal and hydrate formation. For this reason, we recommend using a filter drier and a sight glass with a moisture indicator.

# 6| Compressor assembly

## 6.7 Operating the shut-off valves

- Before opening or closing the shut-off valve, release the valve spindle seal by approx.  $\frac{1}{4}$  of a turn counter-clockwise.
- After activating the shut-off valve, re-tighten the adjustable valve spindle seal clockwise.

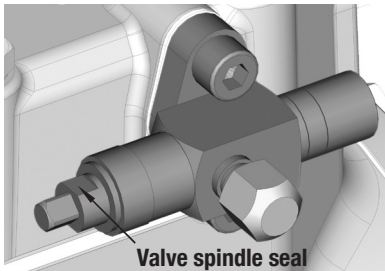

Fig. 7

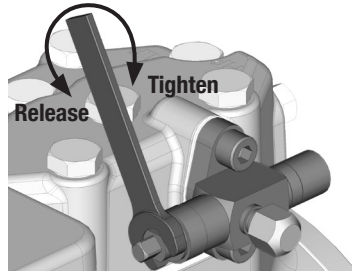

Fig. 8

## 6.8 Operating mode of the lockable service connections

GB

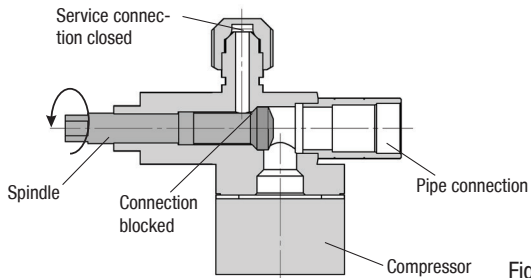

Fig. 9

### Opening the shut-off valve:

Spindle: turn to the left (counter-clockwise) as far as it will go.

—> Shut-off valve completely opened / service connection closed.

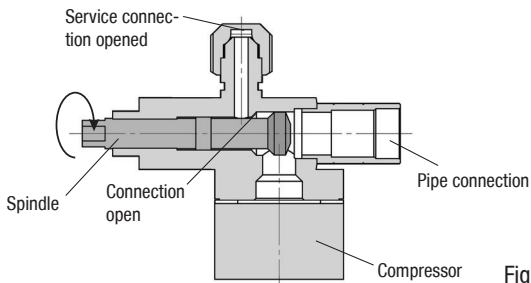

Fig. 10

### Opening the service connection

Spindle: Turn  $\frac{1}{2}$  - 1 turn to the right clockwise.

—> Service connection opened / shut-off valve opened.

After activating the spindle, generally fit the spindle protection cap again and tighten with 14 - 16 Nm. This serves as a second sealing feature during operation.

# 7| Electrical connection



## DANGER

**Risk of electric shock! High voltage!**

**Only carry out work when the electrical system is disconnected from the power supply!**



## ATTENTION

**When attaching accessories with an electrical cable, a minimum bending radius of 3 x the cable diameter must be maintained for laying the cable.**



## INFO

Connect the compressor motor in accordance with the circuit diagram (see inside of terminal box).

- Use suitable cable entry point of the correct protection type (see name plate) for routing cables into the terminal box. Insert the strain reliefs and prevent chafe marks on the cables.
- Compare the voltage and frequency values with the data for the mains power supply.

**Only connect the motor if these values are the same.**

### 7.1 Information for contactor and motor contactor selection

All protection devices and switching or monitoring units must be fitted in accordance with the local safety regulations and established specifications (e.g. VDE) as well as with the manufacturer's information. **Motor protection switches are required!** Motor contactors, feed lines, fuses and motor protection switches must be rated on the basis of the maximum working current (see name plate). For motor protection use a current-dependent and time-delayed overload protection device for monitoring all three phases. Set the overload protection device so that it must be actuated within 2 hours, if there is 1.2 times the max. working current.

### 7.2 Connection of the driving motor

The compressor is designed with a motor for star-delta circuits.

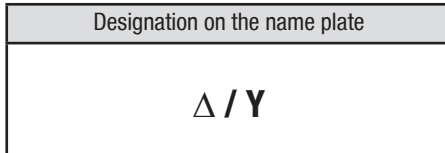

Star-delta start-up is only possible on 230 V voltage supply. Example:

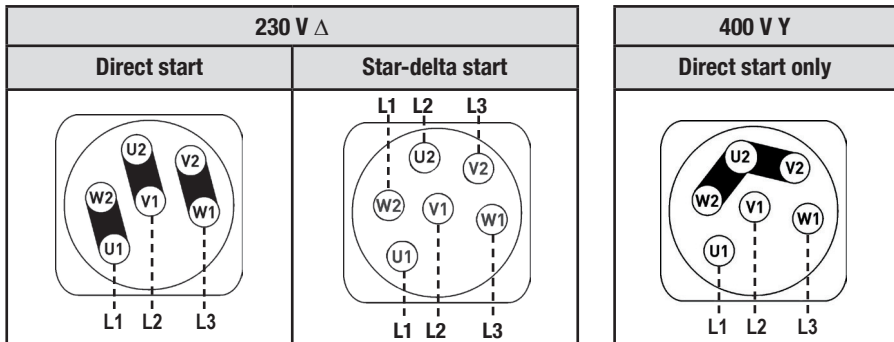

## INFO

**The connection examples shown refer to the standard version. In the case of special voltages, the instructions affixed to the terminal box apply.**

### 7.3 Circuit diagram for direct start 230 V $\Delta$ / 400 V Y

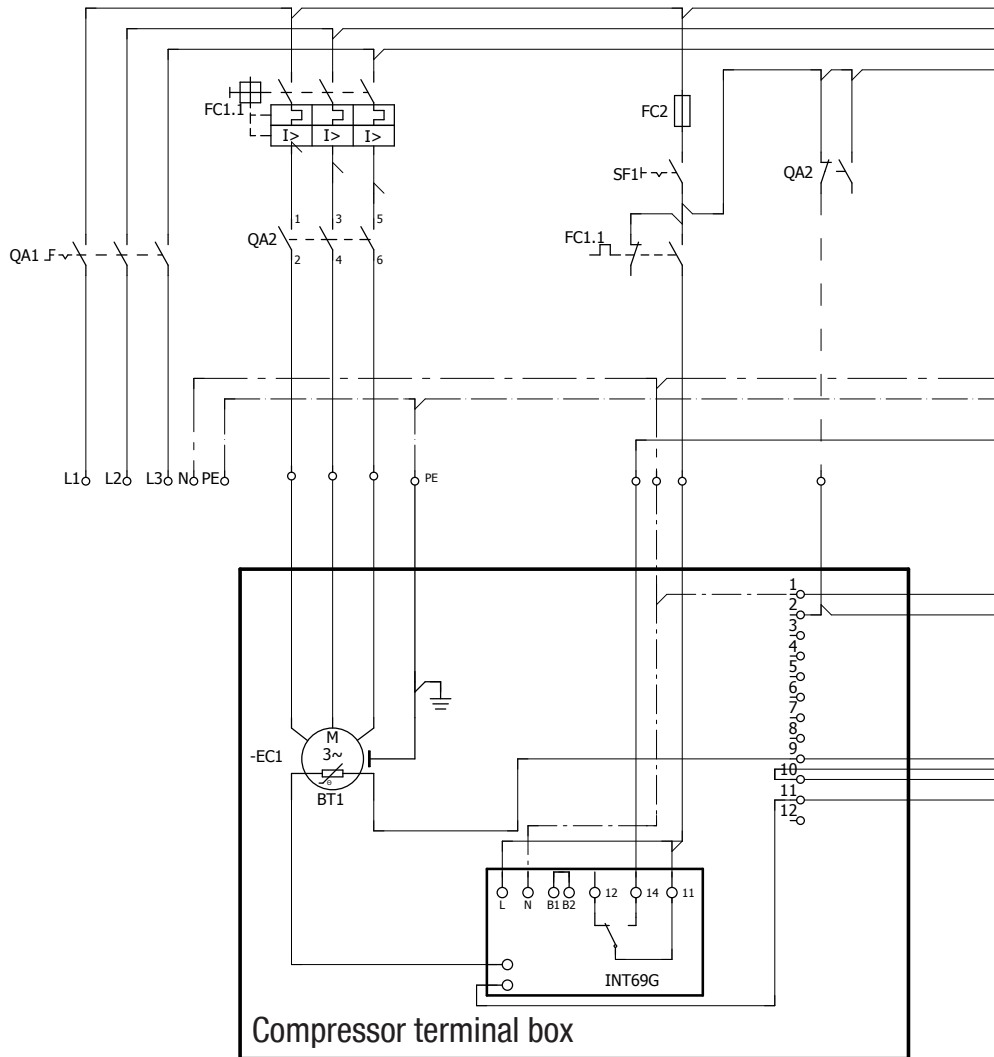
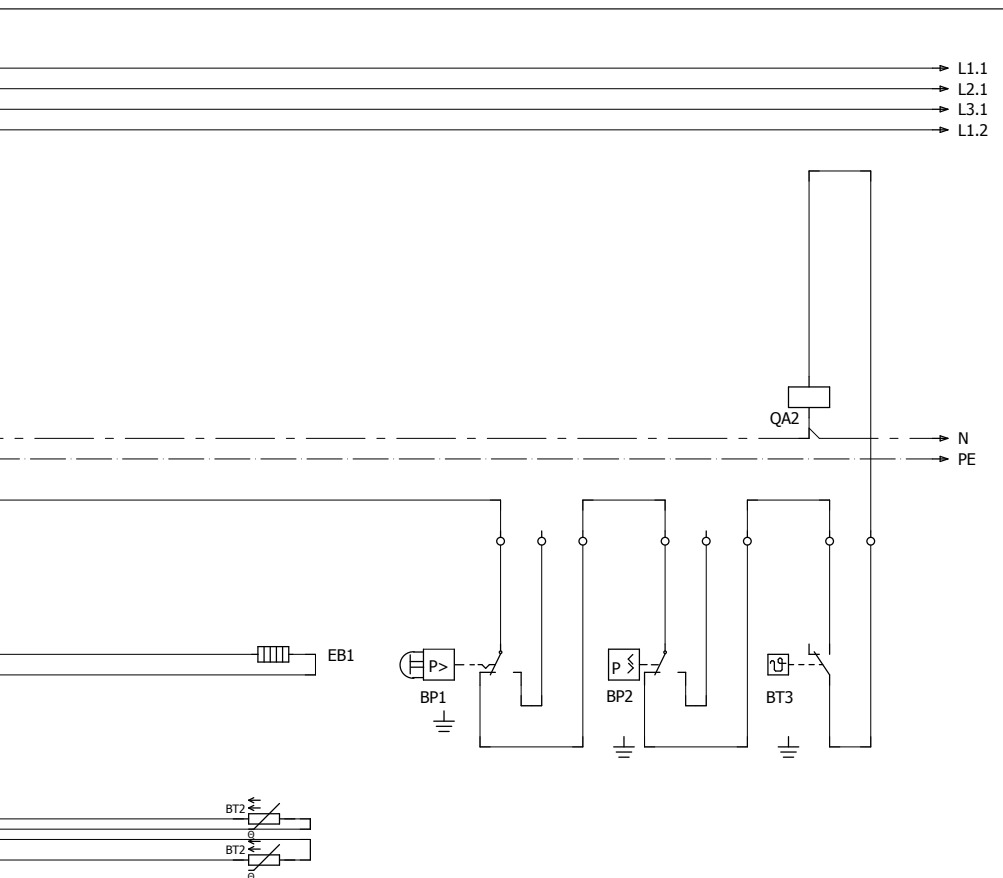

Fig. 11

BT1	Cold conductor (PTC sensor) motor winding
BT2	Thermal protection thermostat (PTC sensor)
FC1	Load circuit safety switches
FC2	Control power circuit fuse
BP1	High pressure safety monitor
BP2	Safety chain (high/low pressure monitoring)
BT3	Release switch (thermostat)



**GB**

**! DANGER**      **Explosion risk!**  
**Electronic trigger INT69 G at HC and LG compressors has to be installed outside any danger area!**  
**See also chapter 7.7.**

QA1	Main switch
SF1	Control voltage switch
EC1	Compressor motor
QA2	Compressor contactor
INT69 G	Electronic trigger unit INT69 G
EB1	Oil sump heater

# 7| Electrical connection

## 7.4 Electronic trigger unit INT69 G

The compressor motor is fitted with cold conductor temperature sensors (PTC) connected to the electronic trigger unit INT69 G in the terminal box. In case of excess temperature in the motor winding, the INT69 G deactivates the motor contactor. Once cooled, it can be restarted only if the electronic lock of the output relay (terminals B1+B2) is released by interrupting the supply voltage.

The hot gas side of the compressor can also be protected against overtemperature using thermal protection thermostats (accessory).

**The unit trips when an overload or inadmissible operating conditions occur. Find and remedy the cause.**



INFO

The relay switching output is executed as a floating changeover contact. This electrical circuit operates according to the quiescent current principle, i.e. the relay drops into a the idle position and deactivates the motor contactor even in case of a sensor break or open circuit.

GB

## 7.5 Connection of the trigger unit INT69 G



INFO

Connect the trigger unit INT69 G in accordance with the circuit diagram. Protect the trigger unit with a delayed-action fuse (FC2) of max. 4 A. In order to guarantee the protection function, install the trigger unit as the first element in the control power circuit.



### ATTENTION

Measure circuit BT1 and BT2 (PTC sensor) must not come into contact with external voltage. This would destroy the trigger unit INT69 G and PTC sensors.

This would destroy the trigger unit INT69 G and PTC sensors.

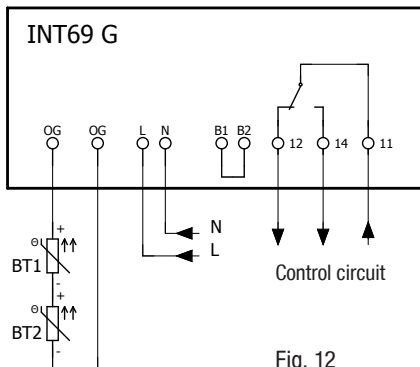

Fig. 12  
Terminal box

# 7 | Electrical connection

## 7.6 Function test of the trigger unit INT69 G

Before commissioning, after troubleshooting or making changes to the control power circuit, check the functionality of the trigger unit. Perform this check using a continuity tester or gauge.

	Gauge state	Relay position
1.	Deactivated state	11-12
2.	INT69 G switch-on	11-14
3.	Remove PTC connector	11-12
4.	Insert PTC connector	11-12
5.	Reset after mains on	11-14

Relay position INT69 G

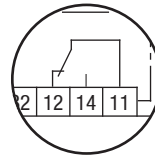

Fig. 13

## 7.7 Electronic trigger unit INT69 G at HC and LG compressors

The supplied INT69 G must be connected according to the wiring diagram shown here in a separate control cabinet, which must be installed outside each danger zone.



**ATTENTION** Install heat protection thermostats and cold conductor motor winding in series!

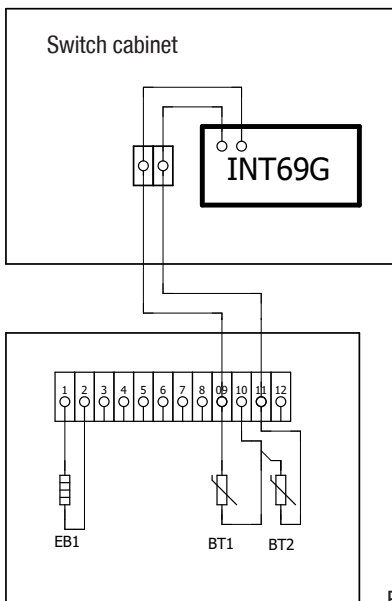

Fig. 14

BT1	Cold conductor (PTC sensor) motor winding
BT2	Heat protection thermostat (PTC sensor)
EB1	Oil sump heater

GB

# 7 | Electrical connection

## 7.8 Oil sump heater at HC and LG compressors

As the solubility of hydrocarbons and HFO refrigerants in oil can be very high, especially at high suction pressures, the compressor must be equipped with an oil sump heater. For this reason, a pump-down circuit is recommended during standstill to reduce the suction-side standstill pressures.



**ATTENTION** The oil sump heater must generally be connected and operated!

- In a TT- or TN system, a residual current protection device (RCD) must be used.
- In an IT system, an insulation monitoring device must be used.

**National standards and regulations must be observed.**

## 7.9 Selection and operation of compressors with frequency converters

For safe operation of the compressor, the frequency converter must be able to apply an overload of at least 140% of the compressor's maximum current (I-max.) for at least 3 seconds.

When using frequency converters, the following things must also be observed

1. The maximum permissible operating current of the compressor (I-max) (see type plate or technical data) must not be exceeded.
2. If abnormal vibrations occur in the system, the affected frequency ranges in the frequency converter must be blanked out accordingly.
3. The maximum output current of the frequency converter must be greater than the maximum current of the compressor (I-max).
4. After each compressor start, run for at least 1 minute at a minimum frequency of 50 Hz.
5. Carry out all designs and installations in accordance with the local safety regulations and common rules (e.g. VDE) and regulations as well as in accordance with the specifications of the frequency converter manufacturer.

The permissible frequency range can be found in the chapter 10.

<b>Rotational speed range</b>	0 - f-min	f-min - f-max
<b>Start-up time</b>	< 1 s	ca. 4 s
<b>Switch-off time</b>	immediately	

# 8 | Commissioning

## 8.1 Preparations for start-up



### INFO

To protect the compressor against inadmissible operating conditions, high pressure and low pressure pressostats are mandatory on the installation side.

The compressor has undergone trials in the factory and all functions have been tested. There are therefore no special running-in instructions.

**Check the compressor for transport damage!**

## 8.2 Pressure strength test

The compressor has been tested in the factory for pressure integrity. If however the entire system is to be subjected to a pressure integrity test, this should be carried out in accordance with EN 378-2 or a corresponding safety standard **without the inclusion of the compressor**.

## 8.3 Leak test



### DANGER

**Risk of bursting!**

**The compressor must only be pressurised using nitrogen (N<sub>2</sub>). Never pressurise with oxygen or other gases!**

**The maximum permissible overpressure of the compressor must not be exceeded at any time during the testing process (see name plate data)! Do not mix any refrigerant with the nitrogen as this could cause the ignition limit to shift into the critical range.**

- Carry out the leak test on the refrigerating plant in accordance with EN 378-2 or a corresponding safety standard, while always observing the maximum permissible overpressure for the compressor.

## 8.4 Evacuation



### ATTENTION

**Do not start the compressor if it is under vacuum. Do not apply any voltage - even for test purposes (must only be operated with refrigerant).**

Under vacuum, the spark-over and creepage current distances of the terminal board connection bolts shorten; this can result in winding and terminal board damage.

- First evacuate the **system** and then include **the compressor in the evacuation process**.
- Relieve the compressor pressure.
- Open the suction and pressure line shut-off valves.
- Evacuate the suction and discharge pressure sides using the vacuum pump.
- At the end of the evacuation process, the vacuum should be < 1.5 mbar when the pump is switched off.
- Repeat this process as often as is required.
- **For HC and LG compressors suitable equipment approved for flammable refrigerants must be used.**

# 8 | Commissioning

## 8.5 Refrigerant charge



### CAUTION

**Wear personal protective clothing such as goggles and protective gloves!**

- Make sure that the suction and pressure line shut-off valves are open.
- With the compressor switched off, add the liquid refrigerant directly to the condenser or receiver, breaking the vacuum.
- If the refrigerant needs topping up after starting the compressor, it can be topped up in vapour form on the suction side, or, taking suitable precautions, also in liquid form at the inlet to the evaporator.



### ATTENTION

- **Avoid overfilling the system with refrigerant!**
- **To avoid shifts in concentration, zeotropic refrigerant blends (e.g. R407C) must always only be filled into the refrigerating plant in liquid form.**
- **Do not pour liquid coolant through the suction line valve on the compressor.**
- **It is not permissible to mix additives with the oil and refrigerant.**

GB

## 8.6 Start-up



### WARNING

**Ensure that both shut-off valves are open before starting the compressor!**

- Check that the safety and protection devices (pressure switch, motor protection, electrical contact protection measures, etc.) are all functioning properly.
- Switch on the compressor and allow to run for a minimum of 10 min.
- **Check the oil level by:** The oil must be visible in the sightglass.



### ATTENTION

**If larger quantities of oil have to be topped up, there is a risk of oil hammer effects.  
If this is the case check the oil return!**

## 8.7 Avoiding slugging



### ATTENTION

**Slugging can damage the compressor and cause refrigerant to leak.**

### To prevent slugging:

- The complete refrigeration system must be properly designed.
- All components must be compatibly rated with each other with regard to output (particularly the evaporator and expansion valves).
- Suction gas superheat at the compressor input **should be min. 7 - 10 K**. (check the setting of the expansion valve). For HC and LG compressors see chapter 5.3.
- The system must reach a state of equilibrium.
- Particularly in critical systems (e.g. several evaporator points), measures are recommended such as replacement of liquid traps, solenoid valve in the liquid line, etc.

# 8| Commissioning

There should be no movement of coolant whatsoever while the compressor is at a standstill.

The use of a check valve is strongly recommended, especially for heat pump applications. Otherwise there is a risk of back condensation, which can result in compressor damage.

## 8.8 Connection of oil level regulator

The connection "O" is provided for installing an oil level regulator. A corresponding adapter must be obtained from the trade.

# 9| Maintenance

## 9.1 Preparation



### WARNING

Before starting any work on the compressor:

- Switch off the compressor and secure it to prevent a restart.
- Relieve compressor of system pressure.
- Prevent air from infiltrating the system!

After maintenance has been performed:

- Connect safety switch.
- Evacuate compressor.
- Release switch lock.

GB

## 9.2 Work to be carried out

In order to guarantee optimum operational reliability and service life of the compressor, **we recommend** carrying out servicing and inspection work at regular intervals:

### ● Oil change:

- not mandatory for factory-produced series systems.
- for field installations or when operating near the application limit: for the first time after 100 to 200 operating hours, then approx. every 3 years or 10,000 - 12,000 operating hours. Dispose of used oil according to the regulations; observe national regulations.

- **Annual checks:** Oil level, leak tightness, running noises, pressures, temperatures, function of auxiliary devices such as oil sump heater, pressure switch.

## 9.3 Spare parts recommendation/accessories

Available spare parts and accessories can be found on our compressor selection tool under [vap.bock.de](http://vap.bock.de) as well as at [bockshop.bock.de](http://bockshop.bock.de).

**Only use genuine Bock spare parts!**

# 9| Maintenance

## 9.4 Lubricants / oil

The oil type filled as standard in the factory is marked on the **name plate**, and this should always be used, even in the case of maintenance units. **Alternative oil types** can vary significantly in quality due to additives or inferior raw materials by the manufacturer. Validation within the compressors entire operating limits can not be guaranteed, if such alternative oil types are used. It is for this reason, that we only recommend the use of oil from Bock! Bock assumes no liability for any damage arising from alternative oil types.

Refrigerants	Bock standard oil types
<b>HFC</b> (e.g. R134a, R407C, R404A)	<b>BOCK</b> lub E55
<b>HFO</b> (e.g. R1234yf, R1234ze, R455A, R454C)	<b>BOCK</b> lub E55 <b>BOCK</b> lub E85 (from $t_0 > 15^{\circ}\text{C}$ )
<b>HCFC</b> (e.g. R22)	<b>BOCK</b> lub A46
<b>HC</b> (e.g. R290)	<b>BOCK</b> lub G68

## 9.5 Decommissioning

Close the shut-off valves on the compressor. Drain the refrigerant (it must not be discharged into the environment) and dispose of it according to the regulations. When the compressor is depressurised, undo the fastening screws of the shut-off valves. Remove the compressor using an appropriate hoist. Dispose of the oil inside in accordance with the applicable national regulations.

GB

## 9.6 Additional information when using flammable refrigerants



### WARNING

- During maintenance and repair, it must be noted that hydrocarbon and synthetic HFO refrigerants residues may dissolve in the oil. Therefore, electrical tests must not be conducted while oil remains in the compressor.
- If the compressor is to be removed from the system for maintenance or repair, the remaining refrigerant must be suctioned out and the compressor evacuated. The compressor must then be filled with nitrogen (max. 0.5 bar) and sealed gas-tight.

# 10 | Technical data

Type*	No. of cylinders	Displacement (1450 / 1740 rpm)		Electrical data ③				Weight	Connections ④		Oil charge (ex works)	Oil charge (sight glass centre)	Sound pressure level
		50 / 60 Hz	m <sup>3</sup> /h	Max. operating current ②	Max. power consumption ②	Starting current (rotor locked) Δ / Y	Permissible frequency range		Discharge line DV	Suction line SV			
HG12P/60-4 S		5.4 / 6.4		6.8 / 3.9	2.2	40 / 23	30-70	48				58.5 / 58 / 57	
HG12P/75-4		6.7 / 8.1		7.1 / 4.1	2.3	40 / 23		48				59 / 58.5 / 58	
HG12P/75-4 S		6.7 / 8.1		8.0 / 4.6	2.6	43 / 25	49					59 / 58.5 / 58	
HG12P/90-4	2	8.0 / 9.6		8.5 / 4.9	2.8	43 / 25	49	12 (1/2)	16 (5/8)	0.8	0.6	59.5 / 59 / 58	
HG12P/90-4 S		8.0 / 9.6		8.8 / 5.1	2.9	45 / 26	49					59.5 / 59 / 58	
HG12P/110-4		9.4 / 11.3		9.2 / 5.3	3.1	43 / 25	49					60 / 59 / 58	
HG12P/110-4 S		9.4 / 11.3		10.6 / 6.1	3.6	45 / 26	49					60 / 59 / 58	

\* The technical data for the HC and LG compressors are identical to the standard compressors. Therefore, these designations are not included in the compressor type specification.

① Tolerance (± 10 %) relative to the mean value of the voltage range.

② - The specifications for max. power consumption apply for 50 Hz operation.

③ All specifications are based on the average of the voltage range

④ For solder connections

⑤ L = low temperature (-35 / 40 °C), M = normal cooling (-10 / 45 °C),

H = air conditioning (5 / 50 °C) sound pressure level measured in

low reflection measuring area, measuring distance 1m.

Compressor operation at 50 Hz (1450 rpm), refrigerant R404A.

Values stated are average values, tolerance ± 2 dB(A).

# 11| Dimensions and connections

## HG12P

(Dimensions and connections for HC and LG compressors are identical to the standard compressors)

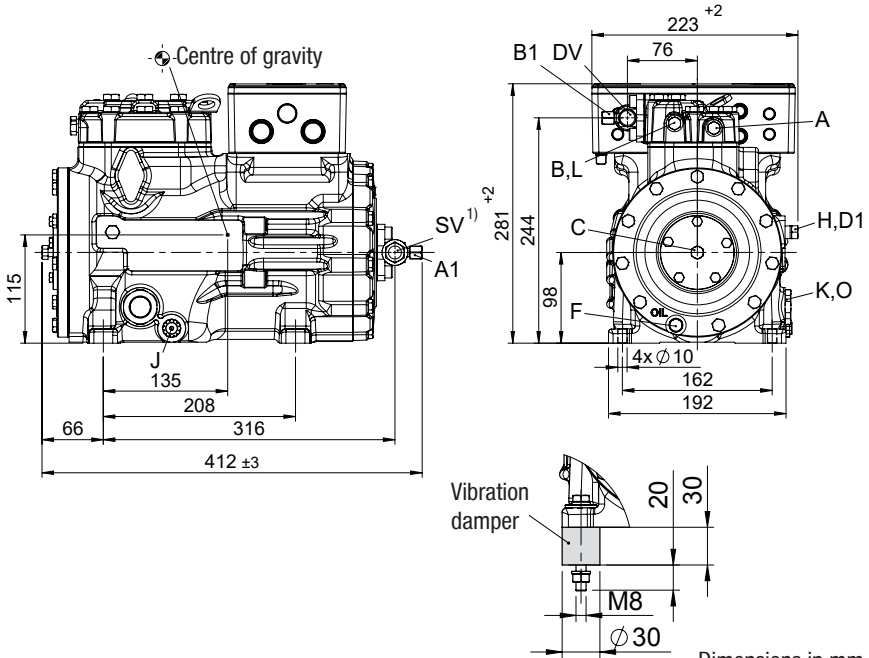

<sup>1)</sup> SV 90° rotatable

Dimensions in mm  
Fig. 15

<b>SV</b>	Suction line	see technical data, Chapter 10	
<b>DV</b>	Discharge line		
<b>A</b>	Connection suction side, not lockable		1/8" NPTF
<b>A1</b>	Connection suction side, lockable		7/16" UNF
<b>B</b>	Connection discharge side, not lockable		1/8" NPTF
<b>B1</b>	Connection discharge side, lockable		7/16" UNF
<b>C</b>	Connection oil pressure safety switch		1/8" UNF
<b>D1</b>	Connection oil return from oil separator		1/4" NPTF
<b>F</b>	Oil drain		M8
<b>H</b>	Oil charge plug		1/4" NPTF
<b>J</b>	Connection oil sump heater		3/8" NPTF
<b>K</b>	Sight glass		1 1/8" - 18 UNEF
<b>L</b>	Connection thermal protection thermostat		1/8" NPTF
<b>O</b>	Connection oil level regulator		1 1/8" - 18 UNEF

# 12 | Declaration of incorporation

## Declaration of incorporation for incomplete machinery in accordance with EC Machinery Directive 2006/42/EC, Annex II 1. B

Manufacturer: Bock GmbH  
Benzstraße 7  
72636 Frickenhausen, Germany

We, as manufacturer, declare in sole responsibility that the incomplete machinery

Name: Semi-hermetic compressor  
Types: HG(X)12P/60-4 S (HC) ..... HG(X)88e/3235-4(S) (HC)  
UL-HGX12P/60 S 0,7 ..... UL-HGX66e/2070 S 60  
HGX12P/60 S 0,7 LG ..... HGX88e/3235 (ML/S) 95 LG  
HG(X)22(P)(e)/125-4 A ..... HG(X)34(P)(e)/380-4 (S) A  
HGX34(P)(e)/255-2 (A) ..... HGX34(P)(e)/380-2 (A)(K)  
HA(X)12P/60-4 ..... HA(X)6/1410-4  
HAX22e/125 LT 2 LG ..... HAX44e/665 LT 14 LG  
HGX12e/20-4 (ML/S) CO<sub>2</sub> (LT) ..... HGX44e/565-4 S CO<sub>2</sub>  
UL-HGX12e/20 (S/ML) 0,7 CO<sub>2</sub> (LT)... UL-HGX44e/565 S 31 CO<sub>2</sub>  
HGX12/20-4 (ML/S/SH) CO<sub>2</sub>T ..... HGX46/440-4 (ML/S/SH) CO<sub>2</sub> T  
UL-HGX12/20 ML(P) 2 CO<sub>2</sub>T ..... UL-HGX46/440 ML(P) 53 CO<sub>2</sub>T  
HGZ(X)7/1620-4 ..... HGZ(X)7/2110-4  
HGZ(X)66e/1340 LT 22 ..... HGZ(X)66e/2070 LT 35  
HRX40-2 CO<sub>2</sub> T H ..... HRX60-2 CO<sub>2</sub> T H

Name: Open type compressor  
Types: F(X)2 ..... F(X)88/3235 (NH3)  
FK(X)1 ..... FK(X)3  
FK(X)20/120 (K/N/TK) ..... FK(X)50/980 (K/N/TK)

Serial number: BC00000A001 – BN99999Z999

complies with the following provisions of the above-mentioned Directive:

According to Annex I, points 1.1.2, 1.1.3, 1.1.5, 1.3.2, 1.3.3, 1.3.7, 1.5.1, 1.5.2, 1.5.13 and 1.7.1 to 1.7.4 (excepted 1.7.4 f) are fulfilled.

Applied harmonised standards, in particular:

EN ISO 12100 :2010 Safety of machinery — General principles for design — Risk assessment and risk reduction  
EN 12693 :2008 Refrigerating systems and heat pumps — Safety and environmental requirements — Positive displacement refrigerant compressors

Remarks: We also declare that the special technical documentation for this incomplete machine has been created in accordance with Annex VII, Part B and we obligate to provide these upon reasoned request from the individual national authorities by data transfer.

Commissioning is prohibited until it has been confirmed that the machinery into which the incomplete machine above is to be incorporated complies with the EC Machinery Directive and an EC Declaration of Conformity, Annex II. 1. A exists.

Authorized person for compiling and handing  
over technical documentation:

Bock GmbH  
Alexander Layh  
Benzstraße 7  
72636 Frickenhausen, Germany

Frickenhausen, 04th of January 2021



i. A. Alexander Layh, Global Head of R&D

# 12 | Declaration of incorporation

## Declaration of incorporation of partly completed machinery in accordance with UK Statutory Instrument Supply of Machinery (Safety) Regulations 2008, Annex II 1. B

Manufacturer: Bock GmbH  
Benzstraße 7  
72636 Frickenhausen, Germany



We, as manufacturer, declare in sole responsibility that the partly completed machinery

Name: Semi-hermetic compressor  
Types: HG(X)12P/60-4 S (HC) ..... HG(X)88e/3235-4(S) (HC)  
UL-HGX12P/60 S 0,7 ..... UL-HGX66e/2070 S 60  
HGX12P/60 S 0,7 LG ..... HGX88e/3235 (ML/S) 95 LG  
HG(X)22(P)(e)/125-4 A ..... HG(X)34(P)(e)/380-4 (S) A  
HGX34(P)(e)/255-2 (A) ..... HGX34(P)(e)/380-2 (A)(K)  
HA(X)22e/125-4 ..... HA(X)6/1410-4  
HAX22e/125 LT 2 LG ..... HAX44e/665 LT 14 LG  
HGX12e/20-4 (ML/S) CO<sub>2</sub> (LT) ..... HGX44e/565-4 S CO<sub>2</sub>  
UL-HGX12e/20 (S/ML) 0,7 CO<sub>2</sub> (LT)... UL-HGX44e/565 S 31 CO<sub>2</sub>  
HGX12/20-4 (ML/S/SH) CO<sub>2</sub>T..... HGX46/440-4 (ML/S/SH) CO<sub>2</sub> T  
UL-HGX12/20 ML(P) 2 CO<sub>2</sub>T..... UL-HGX46/440 ML(P) 53 CO<sub>2</sub>T  
HGZ(X)7/1620-4 ..... HGZ(X)7/2110-4  
HGZ(X)66e/1340 LT 22..... HGZ(X)66e/2070 LT 35  
HRX40-2 CO<sub>2</sub> T H..... HR(Z)X60-2 CO<sub>2</sub> T (H)(V)

Name: Open type compressor  
Types: F(X)2 ..... F(X)88/3235 (NH3)  
FK(X)1 ..... FK(X)3  
FK(X)20/120 (K/N/TK)..... FK(X)50/980 (K/N/TK)

Serial number: BC00000A001 – BN99999Z999

complies with the following provisions of the above-mentioned Statutory instrument:

According to Schedule 2, part1, points 1.1.2, 1.1.3, 1.1.5, 1.3.2, 1.3.3, 1.3.7, 1.5.1, 1.5.2, 1.5.13 and 1.7.1 to 1.7.4 (excepted 1.7.4 f) are fulfilled.

Designated standards: EN ISO 12100 :2010 Safety of machinery — General principles for design — Risk assessment and risk reduction  
EN 12693 :2008 Refrigerating systems and heat pumps — Safety and environmental requirements — Positive displacement refrigerant compressors

Remarks: We also declare that the special technical documentation for this partly completed machine has been created in accordance with Annex II, 1. B and we obligate to provide these upon reasoned request from the individual national authorities by data transfer.

Commissioning is prohibited until it has been confirmed that the machinery into which the partly completed machine above is to be incorporated complies with the UK Statutory Instrument Supply machinery (Safety) regulations 2008 and an EC Declaration of Conformity, Annex II, 1. A exists.

Authorized person for compiling and handing over technical documentation:

Bock GmbH  
Alexander Layh  
Benzstraße 7  
72636 Frickenhausen, Germany

Frickenhausen, 14th of October 2022

i. A. Alexander Layh, Global Head of R&D



**Danfoss GmbH**

Climate Solutions • danfoss.de • +49 69 8088 5400 • cs@danfoss.de

---

Alle Informationen, einschließlich, aber nicht beschränkt auf Informationen zur Auswahl von Produkten, ihrer Anwendung bzw. ihrem Einsatz, zur Produktgestaltung, zum Gewicht, den Abmessungen, der Kapazität oder zu allen anderen technischen Daten von Produkten in Produkthandbüchern, Katalogbeschreibungen, Werbungen usw., die schriftlich, mündlich, elektronisch, online oder via Download erteilt werden, sind als rein informativ zu betrachten, und sind nur dann und in dem Ausmaß verbindlich, als auf diese in einem Kostenvoranschlag oder in einer Auftragsbestätigung explizit Bezug genommen wird. Danfoss übernimmt keine Verantwortung für mögliche Fehler in Katalogen, Broschüren, Videos und anderen Drucksachen. Danfoss behält sich das Recht vor, ohne vorherige Bekanntmachung Änderungen an seinen Produkten vorzunehmen. Dies gilt auch für bereits in Auftrag genommene, aber nicht gelieferte Produkte, sofern solche Anpassungen ohne substanzielle Änderungen der Form, Tauglichkeit oder Funktion des Produkts möglich sind.  
Alle in dieser Publikation enthaltenen Warenzeichen sind Eigentum von Danfoss A/S oder Danfoss-Gruppenunternehmen. Danfoss und das Danfoss Logo sind Warenzeichen der Danfoss A/S. Alle Rechte vorbehalten.

---