

Rittal – The System.

Faster – better – everywhere.

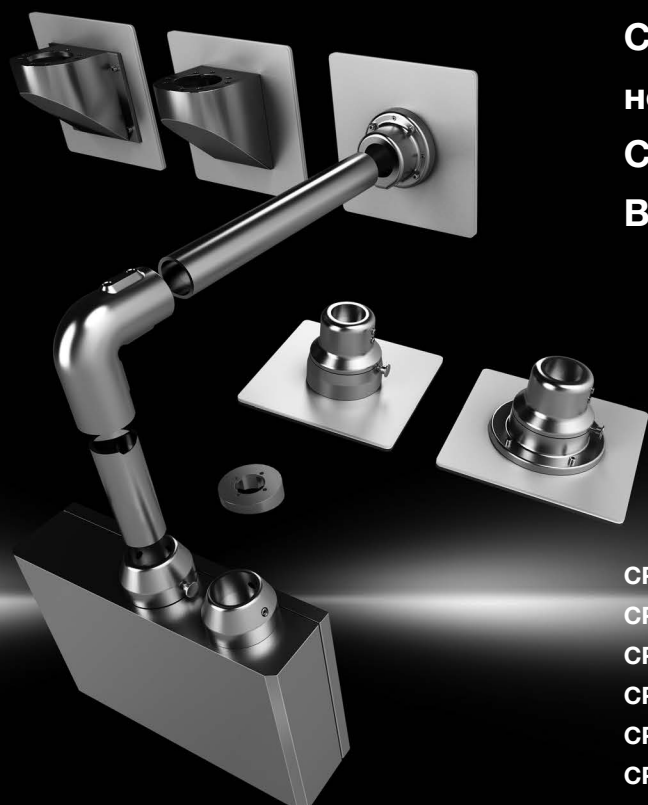

Система несущих рычагов CP 40

нержавеющая сталь

CP 40 Support arm system stainless steel

Bras porteur en acier inoxydable CP 40

CP 6660.010	CP 6664.100
CP 6660.050	CP 6664.300
CP 6663.000	CP 6664.500
CP 6663.400	CP 6665.000
CP 6663.500	CP 6665.500
CP 6664.000	

Руководство по монтажу и эксплуатации
Assembly and operating instructions
Notice d'emploi et de montage

ENCLOSURES

POWER DISTRIBUTION

CLIMATE CONTROL

IT INFRASTRUCTURE







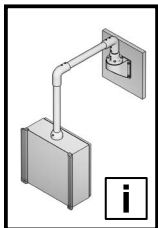

SOFTWARE & SERVICES

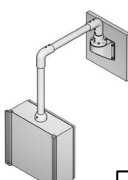
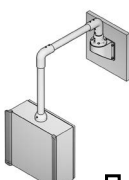
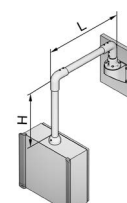
FRIEDHELM LOH GROUP



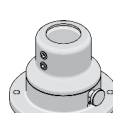
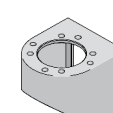
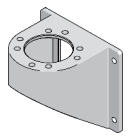

Содержание/Contents/Sommaire

				
2-3, 12	2	3	6663.000 4	6664.300 5
				
6664.500 6	6664.000 7	6663.500 8	6663.400 9	6665.000 10
				
6665.500 11	6664.100 12			

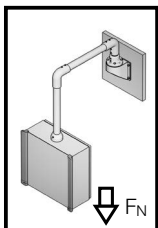

Нагрузочная способность/Load capacity/Charge admissible

Допустимая нагрузка в зависимости от конструкции системы
 Permissible load depending on system configuration
 Charge admissible en fonction de la configuration choisie

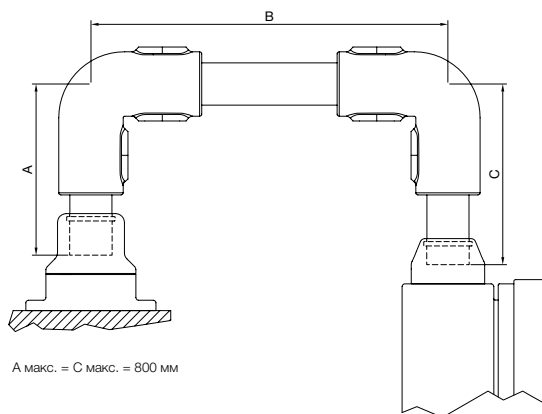
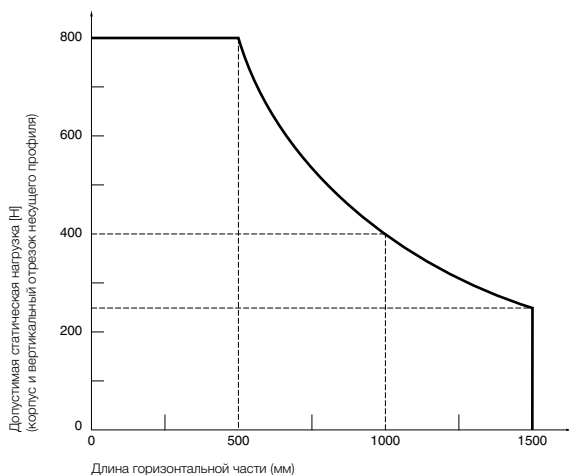

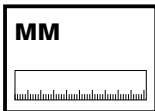
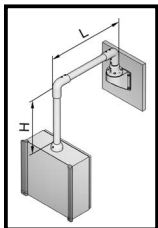

0,7 кг	6664.100	1,3 кг	6664.500	1,1 кг	6664.000
1,3 кг		6664.300		1,7 кг	6663.000
3,9 кг	6663.500	4,5 кг	6663.400	1,5 кг	6665.000
1,8 кг	6665.500	500 мм	2,0 кг	6660.050	
		1000 мм	3,9 кг	6660.010	

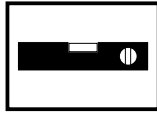
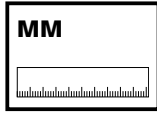
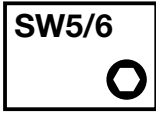
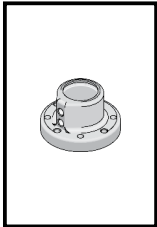

CP 6663.000

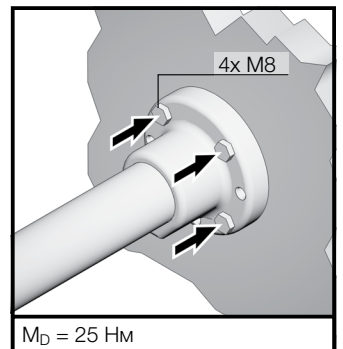
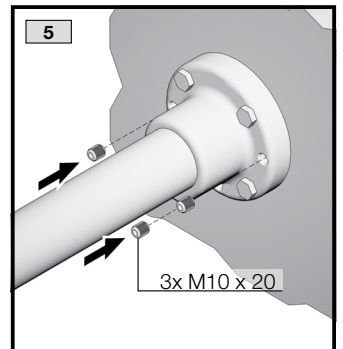
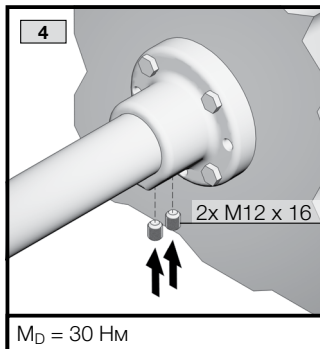
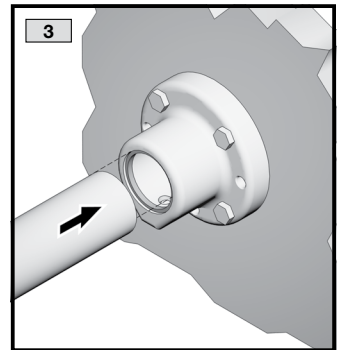
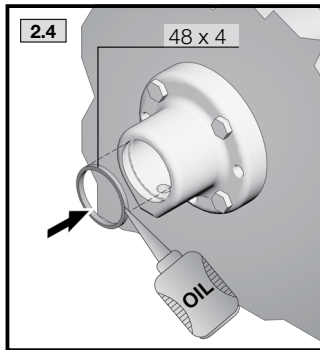
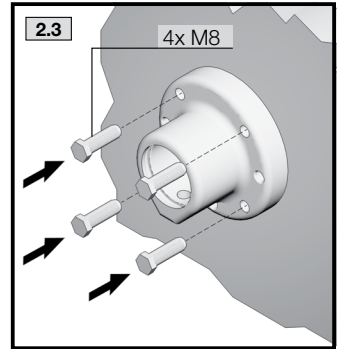
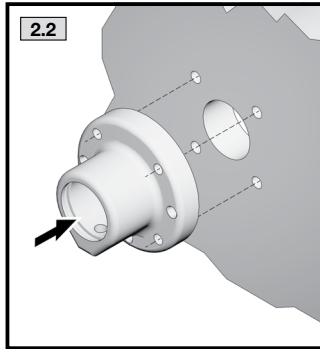
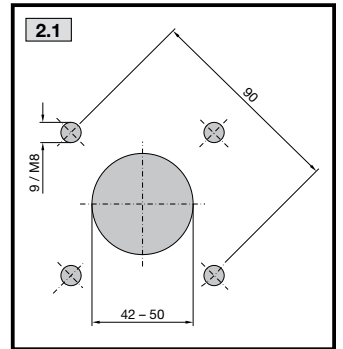
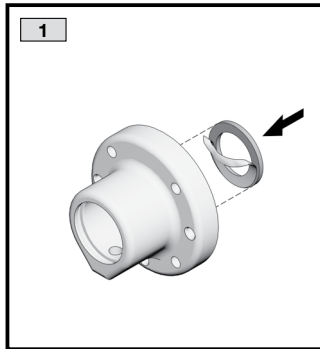
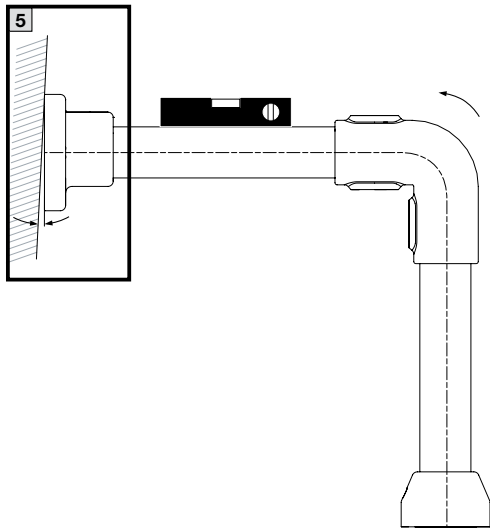
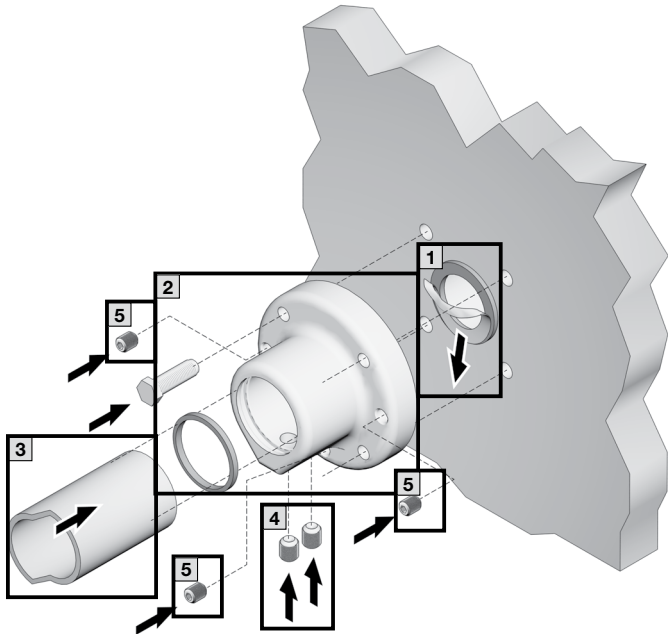

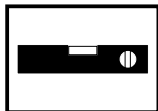
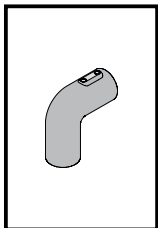

CP 6664.300

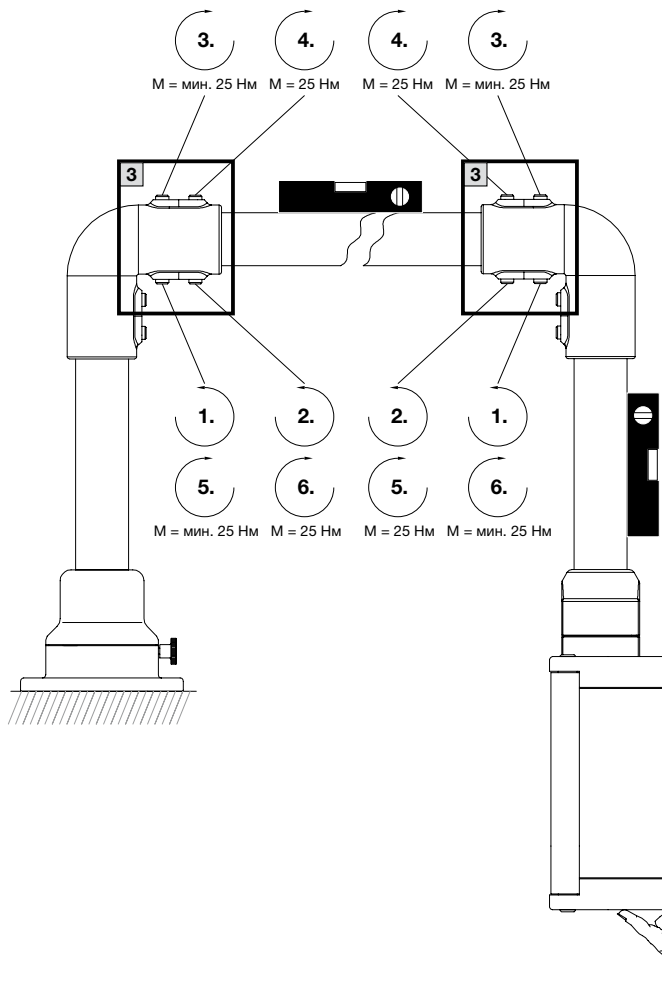
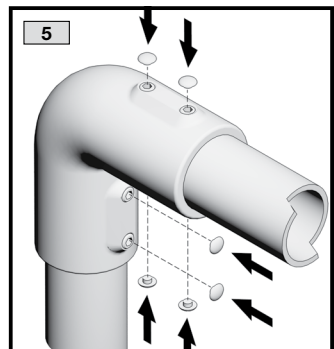
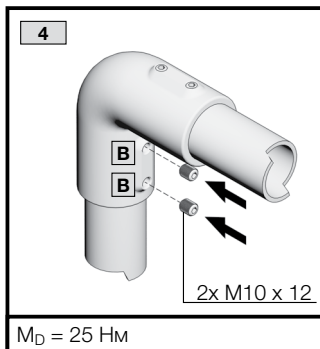
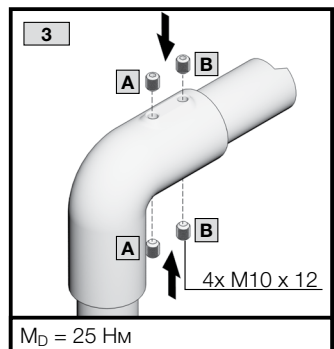
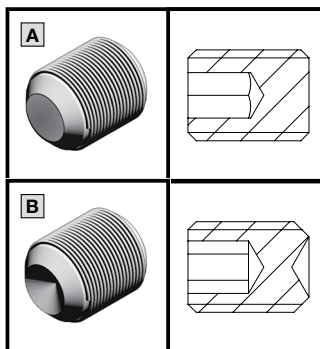
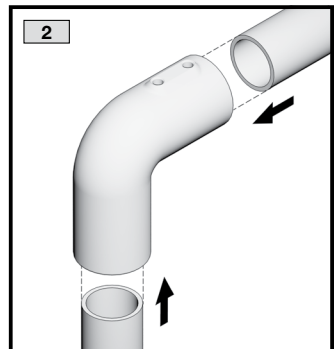
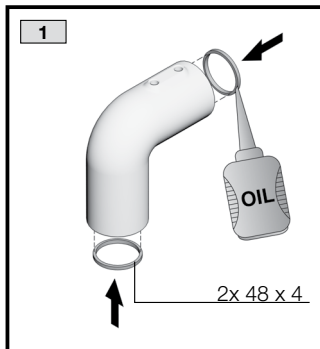
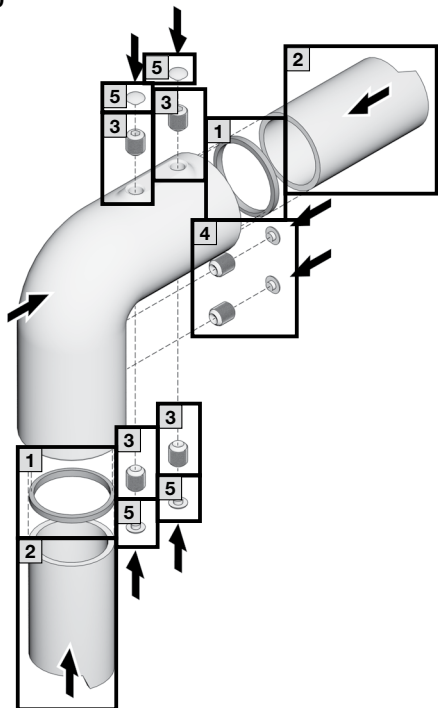

- **ОПАСНОСТЬ!**
 ■ Непосредственная опасность для здоровья и жизни. Соблюдайте указанные на странице 2 данные по нагрузкам. Соблюдайте все указанные моменты затяжки. Превышение или недостижение указанных в этом руководстве моментов затяжки может привести к повреждению установок или к тяжелым или смертельным ранениям.
- Просьба обеспечить надежное и длительное крепление системы несущих рычагов к монтажной поверхности!
- **DANGER!**
 ■ Immediate danger to life and limb. Observe the load specifications given on page 2. Observe all specified tightening torques. If screws or bolts are tightened with torques greater or less than those specified in these instructions, this may result in damage and serious or even fatal injuries.
- Please ensure that the support arm system is securely and permanently fastened to the mounting surface!
- **DANGER!**
 ■ Danger de mort immédiat pour la personne. Respectez les charges mentionnées à la page 2. Respectez les couples indiqués. Un dépassement vers le haut ou vers le bas des couples indiqués dans cette notice peuvent conduire à des dommages au niveau de l'installation ou à de graves blessures qui peuvent même être mortelles.
- Il faut prendre les mesures appropriées pour fixer solidement et de manière durable le bras porteur sur sa surface de montage !



SW4/5

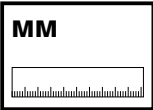

CP 6664.500

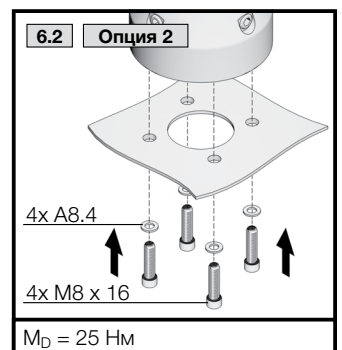
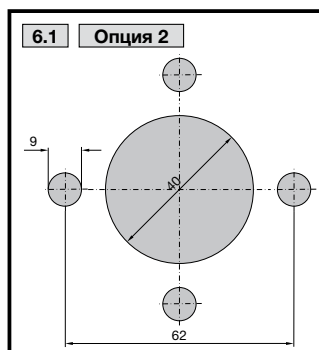
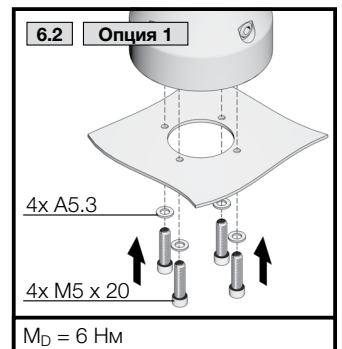
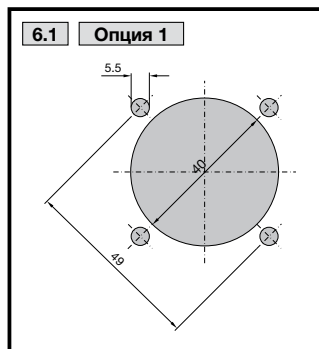
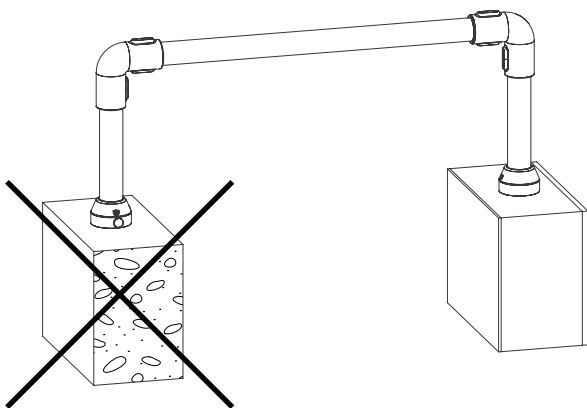
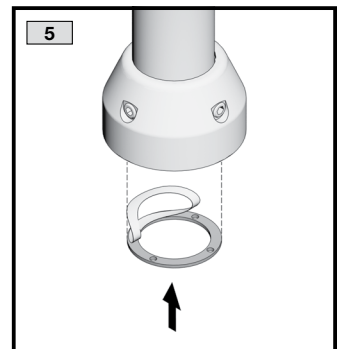
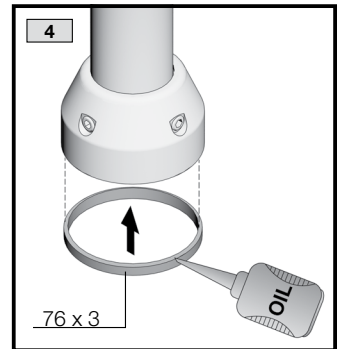
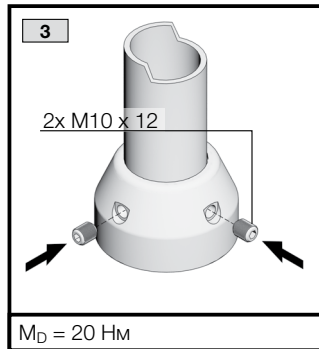
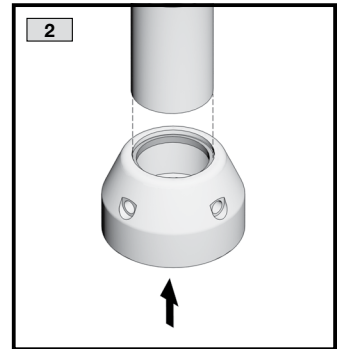
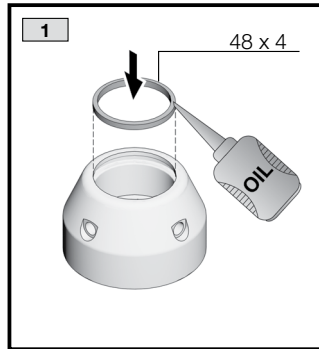
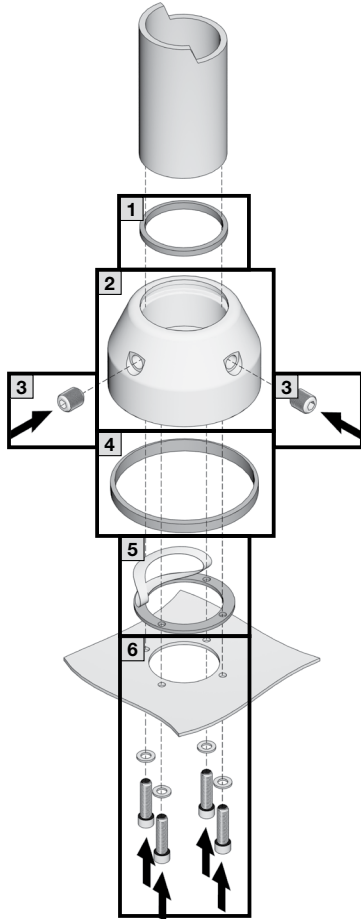

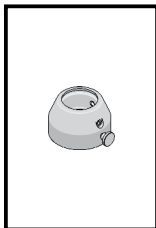

SW4/5

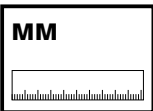

CP 6664.000

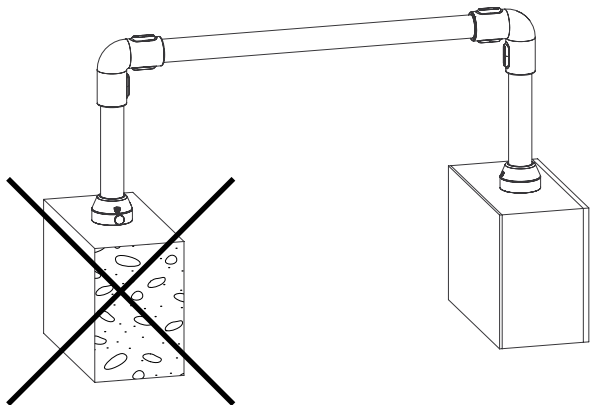
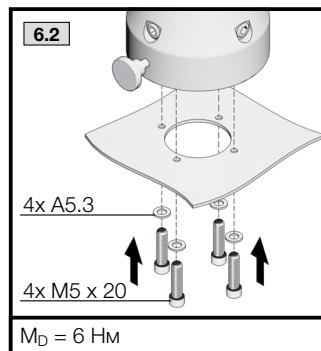
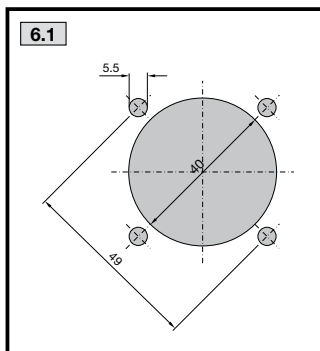
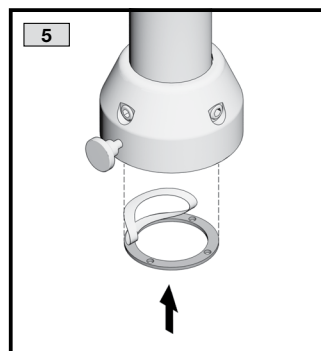
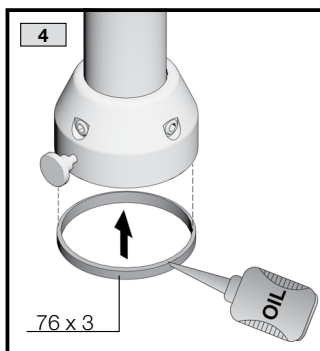
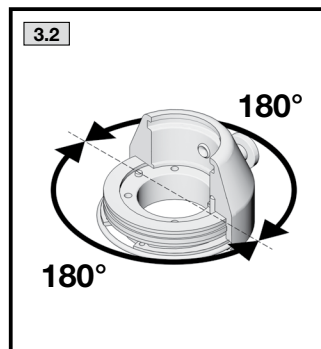
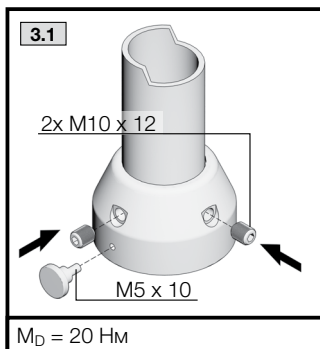
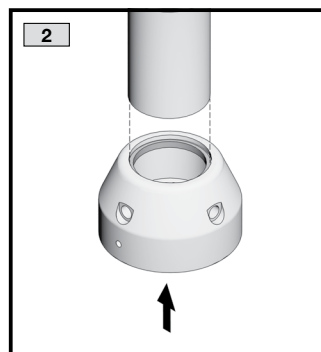
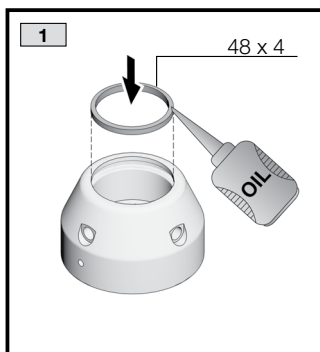
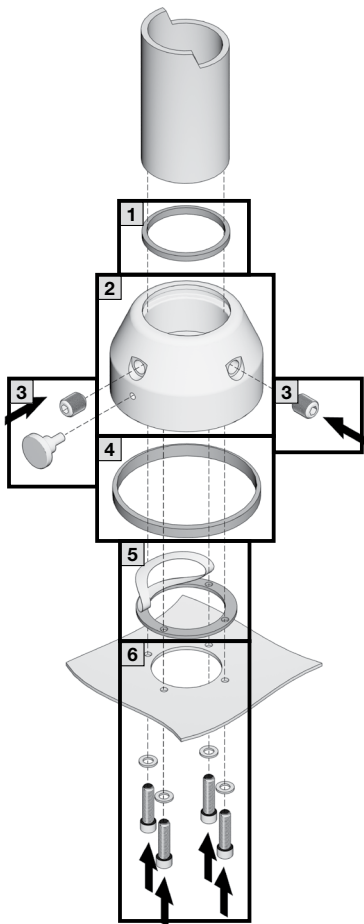

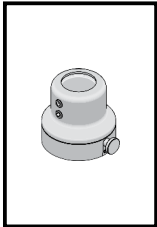

CP 6663.500

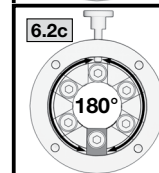
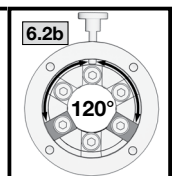
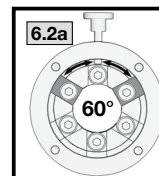
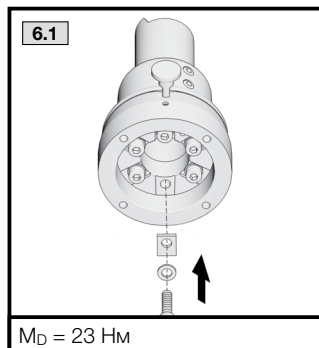
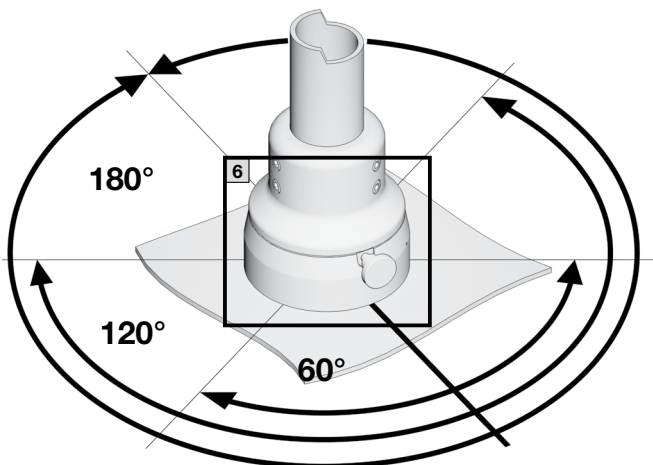
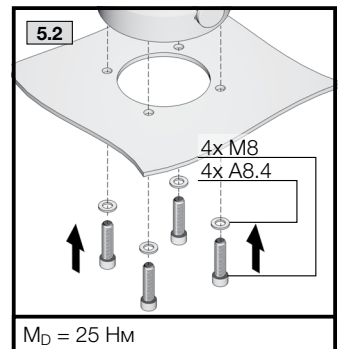
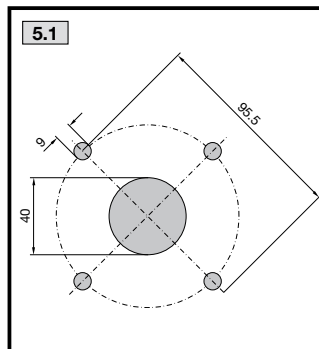
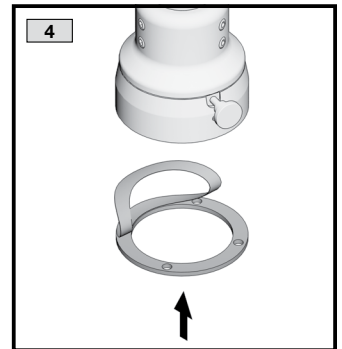
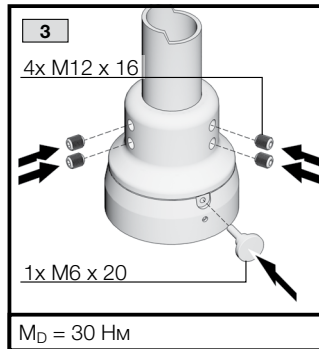
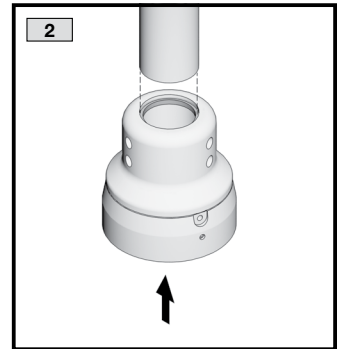
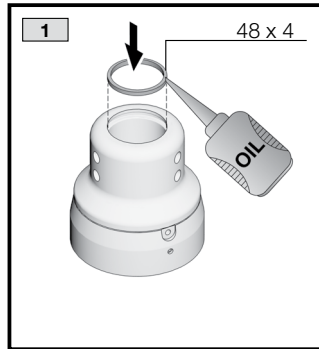
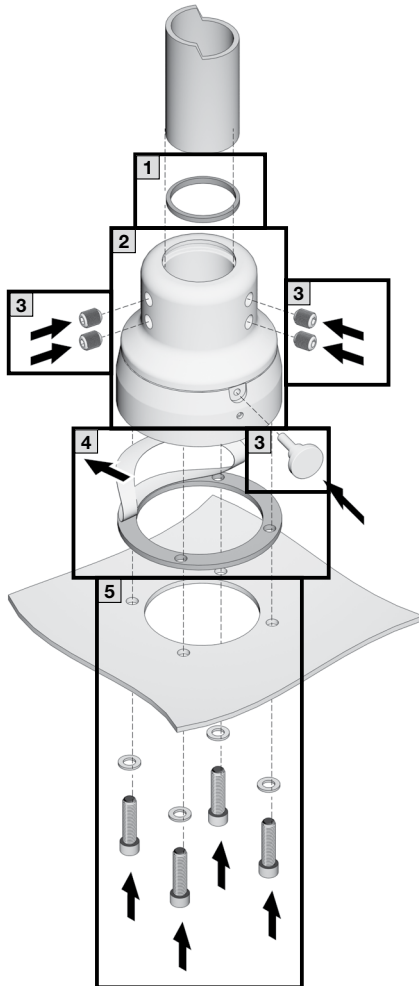
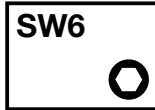

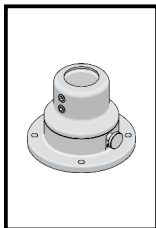

CP 6663.400

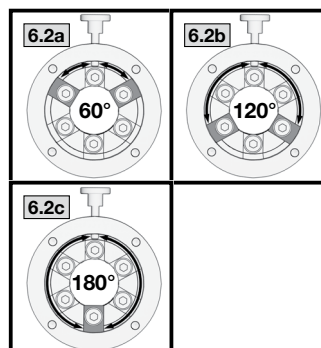
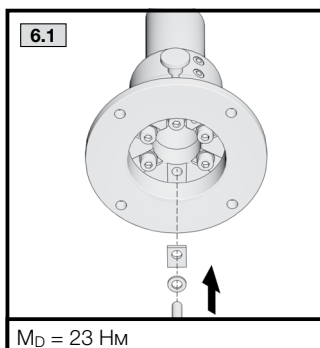
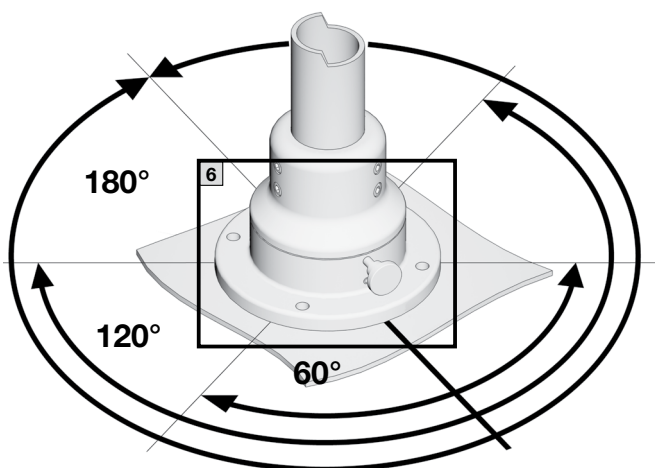
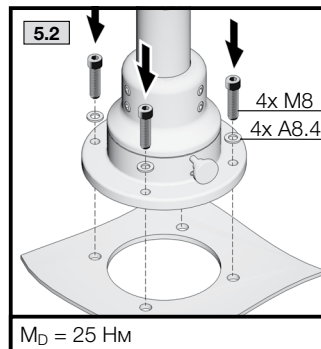
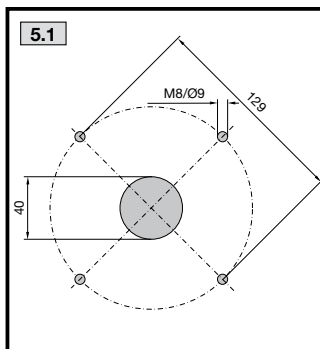
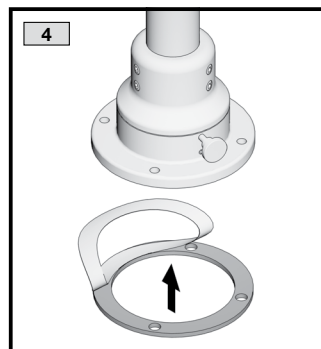
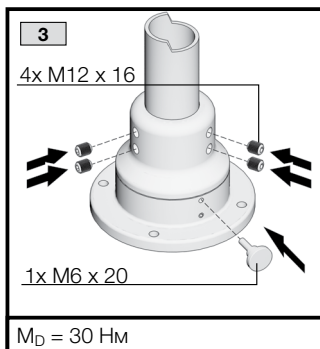
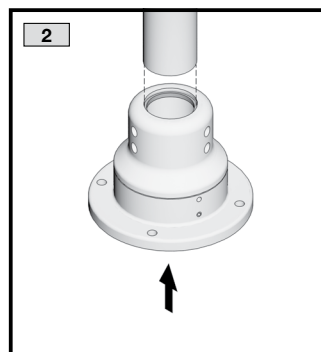
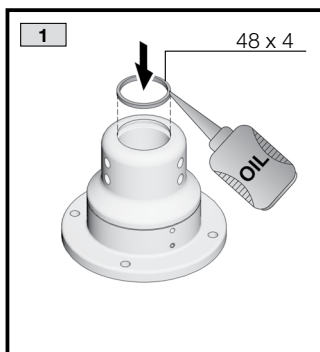
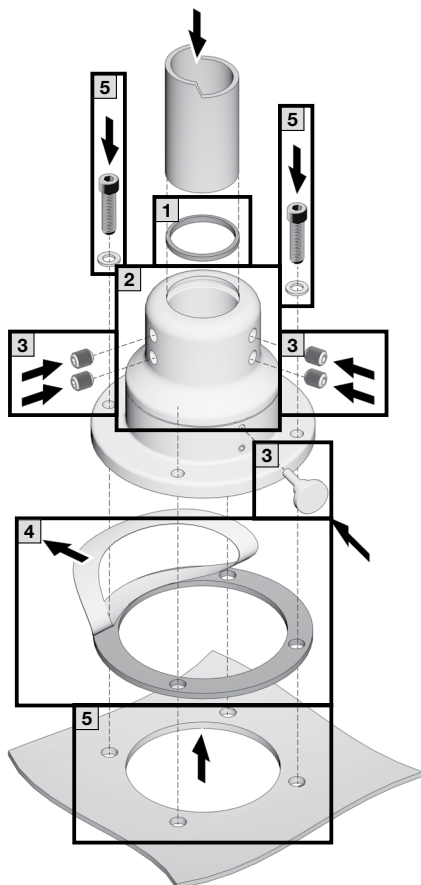

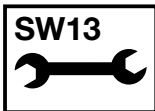
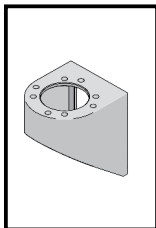

CP 6665.000

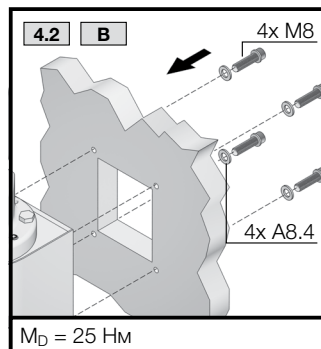
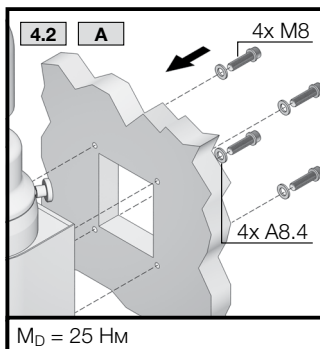
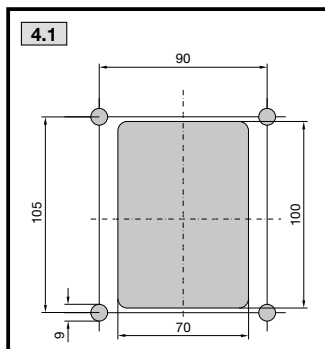
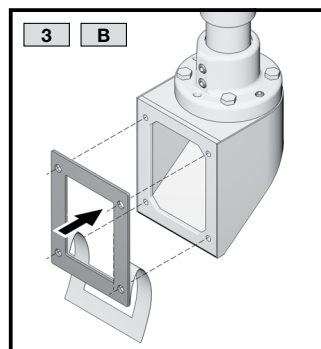
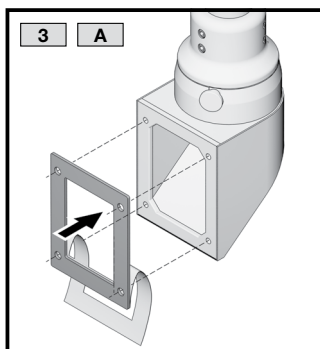
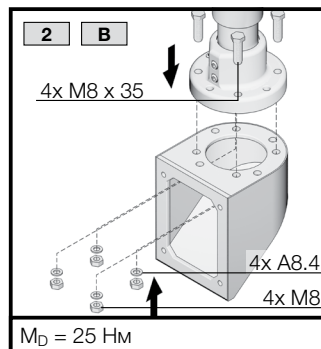
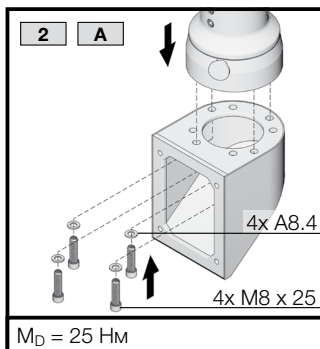
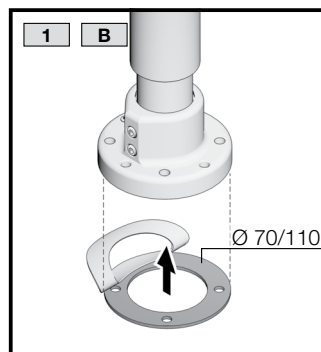
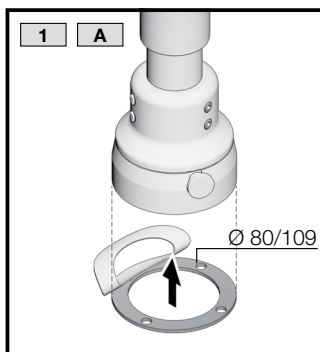
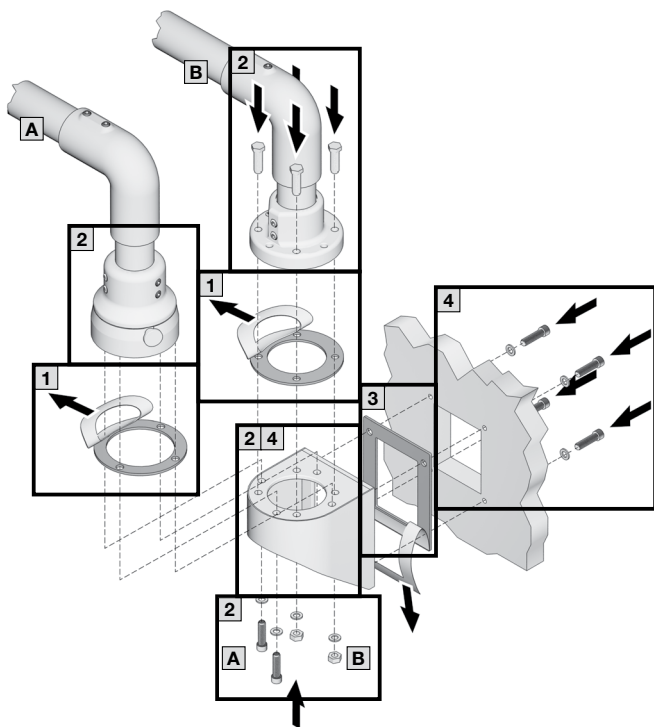

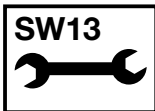
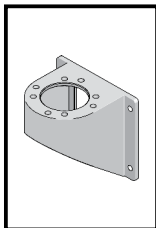

CP 6665.500

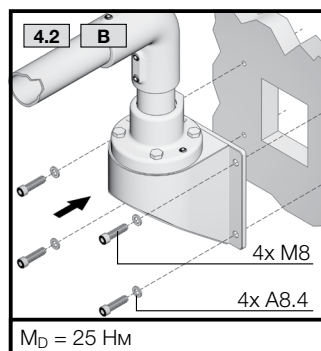
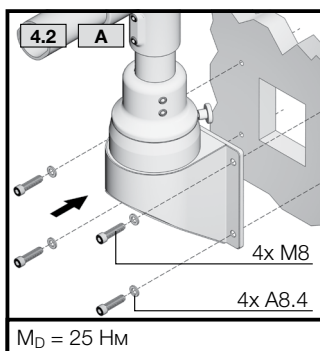
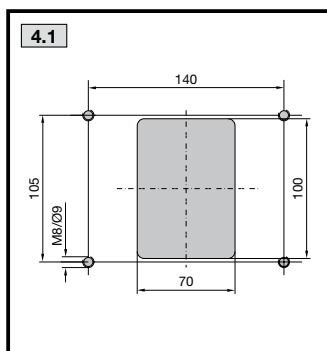
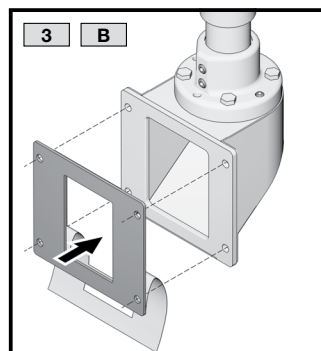
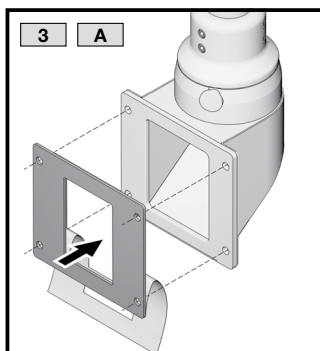
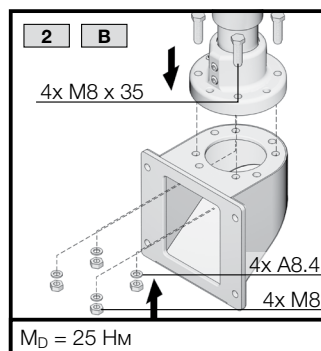
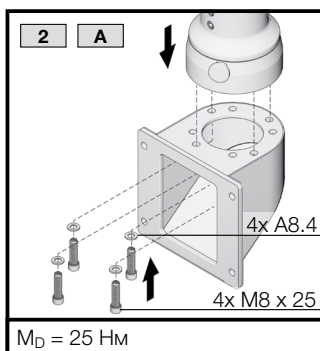
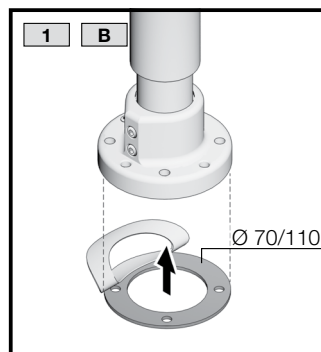
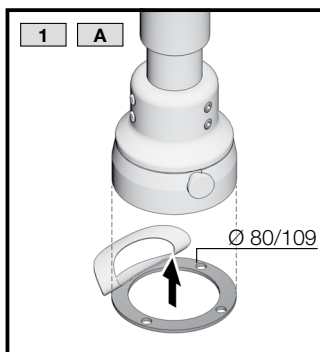
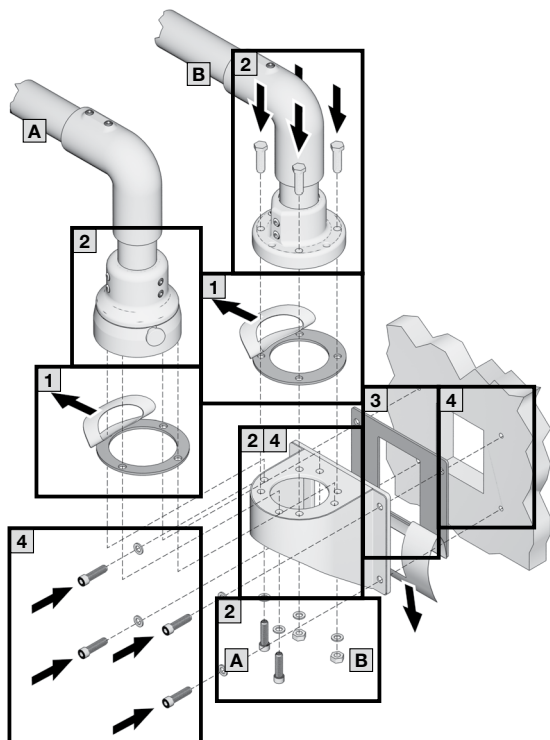

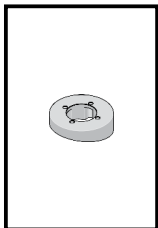

CP 6664.100

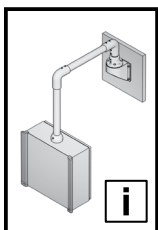
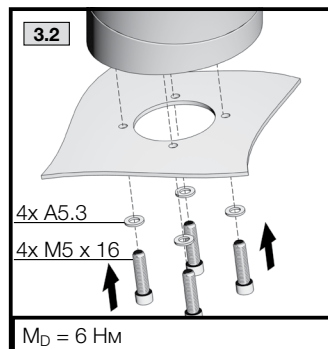
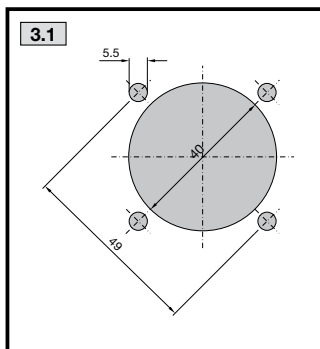
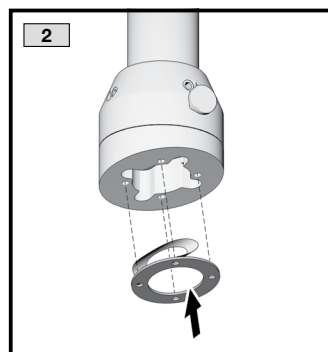
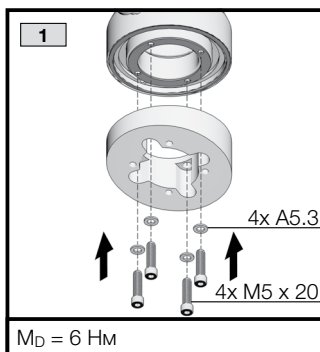
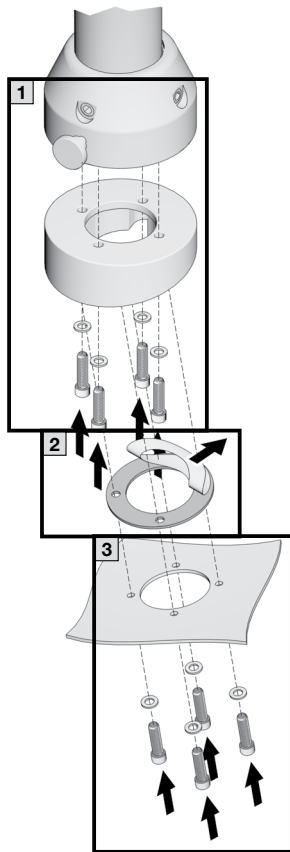
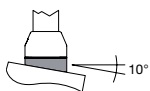

RU	Для транспортировки смонтированные системы несущих рычагов необходимо закрепить соответствующим образом!
EN	Pre-assembled support arm systems must be stabilised securely and protected appropriately for transportation!
F	Des mesures de sécurité adéquates doivent être prises pour le transport des bras porteurs pré-assemblés !
E	¡Deben tomarse las medidas de protección apropiadas para el transporte de los sistemas de brazo soporte!
I	Per il trasporto di sistemi a braccio portante premontati, sono necessarie adeguate misure di sicurezza.
NL	Voor het transport van vooraf gemonteerde draagarmsystemen dienen passende transportbeveiligingsmaatregelen genomen te worden!
S	Förmonterat bärmssystem måste skyddas och stabiliseras på lämpligt sätt för säker transport!
J	組立済みのサポートアームシステムを輸送する際は、適切な輸送対策を実施してください。

Rittal – The System.

Faster – better – everywhere.

- Корпуса
- Электрораспределение
- Контроль микроклимата
- IT-инфраструктура
- ПО и сервис

10.2015/RU-0000-00000444 Rev.00

ООО "Риттал"
Россия · 125252 · г. Москва, ул. Авиаконструктора Микояна, д. 12 (4-й этаж)
Тел.: +7 (495) 775 02 30 · Факс: +7 (495) 775 02 39
E-mail: info@rittal.ru · www.rittal.ru

ENCLOSURES

POWER DISTRIBUTION

CLIMATE CONTROL

IT INFRASTRUCTURE

SOFTWARE & SERVICES



FRIEDHELM LOH GROUP