

Data sheet

PAHT pumps

PAHT 2-6.3/PAHT/10-12.5/PAHT 20-25/
PAHT 50-90 and PAHT 256-308



ЮГОВ - Проект

інженерно-виробниче підприємство

Офіційний дистриб'ютор
Danfoss в Україні



ugov.ua

Table of Contents	1.	Introduction	2
	2.	Benefits	3
	3.	Application examples	3
	4.	Technical data	4
	4.1	PAHT 2-12.5	4
	4.2	PAHT 20-32	5
	4.3	PAHT 50-90	6
	4.4	PAHT 256-308	7
	5.	Flow	8
	5.1	PAHT 2-6.3 typical flow curves at max pressure	8
	5.2	PAHT 10-12.5 typical flow curves at max pressure	9
	5.3	PAHT 20-32 typical flow curves at max pressure	10
	5.4	PAHT 50-90 typical flow curves at max pressure	11
	5.5	PAHT 256-308 typical flow curves at max pressure	12
	6.	Motor requirements	13
	7.	Installation	14
	7.1	Filtration	14
	7.2	Noise	14
	7.3	Open-system design	15
	7.4	Closed-system design	16
	8.	Dimensions and connections	17
	8.1	PAHT 2-6.3	17
	8.2	PAHT 10-12.5	18
	8.3	PAHT 20-32	19
	8.4	PAHT 50-90	20
	8.5	PAHT 256-308	21
	9.	Service	22

1. Introduction

The Danfoss range of PAHT high-pressure pumps is specifically designed for use with technical water such as:

- Ultra-pure water that has undergone multiple reverse osmosis processes
- De-ionized water
- Demineralized water

Danfoss PAHT pumps are positive displacement pumps, with axial pistons that move a fixed amount of water in each cycle. Flow is proportional to the number of input shaft revolutions (rpm). Unlike centrifugal pumps, they produce the same flow at a given speed independently of no matter what the discharge pressure.

Below sectional drawing is an example of a PAHT pump.

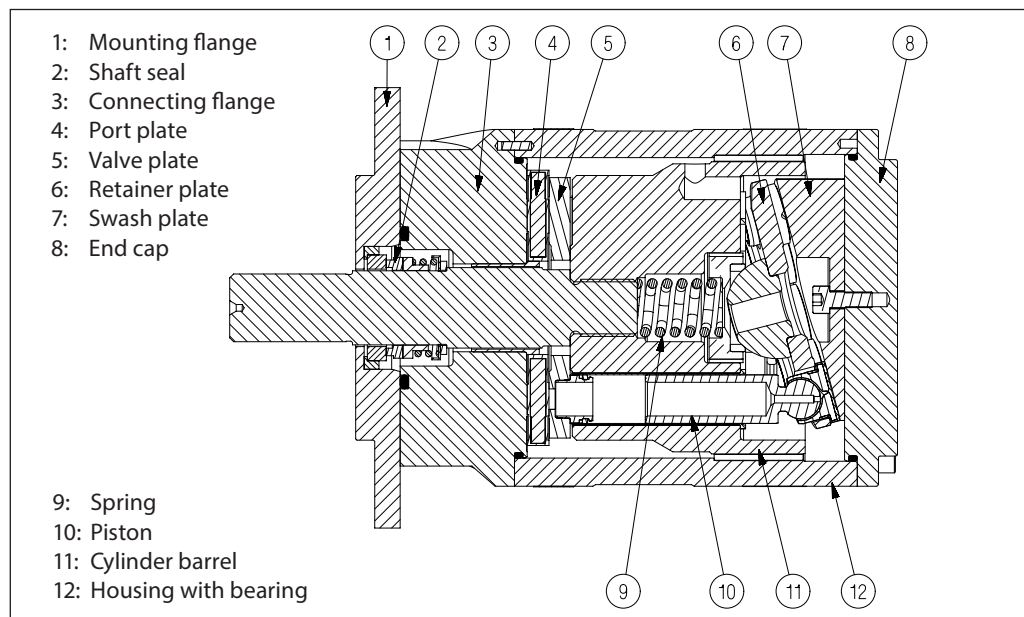

2. Benefits

- **Zero risk of lubricant contamination:**
 - Oil lubricants are replaced with the pumped medium, water, so there is no contamination risk from the pump.
- **Low maintenance costs:**
 - Efficient design and all-stainless steel construction ensure exceptionally long lifetime. When Danfoss specifications are met, service intervals of up to 8,000 hours can be expected. Service is easy, and can be carried out on site due to the simple design and few parts.
- **Low energy costs:**
 - The highly efficient axial piston design provides the lowest energy consumption of any comparable pump on the market.
- **Easy installation:**
 - The lightest and most compact design available.
- **Certified quality:**
 - Pump can be installed horizontally or vertically.
 - No pulsation dampeners necessary due to extremely low-pressure pulsation.
 - Powered by electric motors or combustion engines.
 - Suitable for both boosted inlet pressure and water supply from a tank.
 - No need for cooling circuits due to very high mechanical efficiency.
 - ISO 9001, ISO 14001
 - API available on request

3. Application examples

- High-pressure cleaning with ultra-pure water, as used in the manufacturing of flat-panel displays and many other electronic products.
- High-pressure cleaning with ultra-pure water, as used in the manufacturing of parts for the automobile industry.
- Adiabatic cooling systems to replace or supplement standard A/C systems in server rooms and factories.
- Humidification in office buildings, electronic component manufacturing, dairies, greenhouses, etc.
- Dust suppression and odor control systems, for example in paper, textile and wood production.
- Reduction of NOx emissions in diesel engines and gas turbines.
- Gas turbine by inlet fogging and fuel wash systems.

4. Technical data

4.1 PAHT 2-12.5

Pump size		2	3.2	4	6.3	10	12.5
Code number PAHT		180B0031	180B0077	180B0030	180B0029	180B0032	180B0033
Housing material		AISI 304	AISI 304	AISI 304	AISI 304	AISI 304	AISI 304
Geometric displacement	cm ³ /rev	2	3.2	4	6.3	10	12.5
	in ³ /rev	0.12	0.20	0.24	0.38	0.61	0.76
Pressure							
Min. outlet pressure	barg	10	10	10	10	10	10
	psig	145	145	145	145	145	145
Max. outlet pressure	barg	100	100	100	100	140	140
	psig	1450	1450	1450	1450	2031	2031
Inlet pressure, continuous	barg	0-4	0-4	0-4	0-4	0-4	0-4
	psig	0-58	0-58	0-58	0-58	0-58	0-58
Max. inlet ¹⁾ pressure, peak	barg	4	4	4	4	4	4
	psig	58	58	58	58	58	58
Speed							
Min. speed	rpm	1000	1000	1000	1000	1000	1000
Min. speed, continuous	rpm	1000	1000	1000	1000	1000	1000
Max. speed	rpm	3000	3000	3000	3000	2400	2400
Typical flow - Flow curves available in section 5							
1000 rpm at max. pressure	l/min	0.7	2.0	3.0	5.5	7.6	10.2
1500 rpm at max. pressure	l/min	1.7	3.6	5.0	8.6	12.6	16.5
1200 rpm at max. pressure	gpm	0.3	0.7	1.0	1.8	2.5	3.3
1800 rpm at max. pressure	gpm	0.6	1.2	1.6	2.7	4.0	5.3
Typical motor size							
1500 rpm at max. pressure	kW 50 Hz	0.75	1.1	1.5	2.2	4.0	5.5
1800 rpm at max. pressure	hp 60 Hz	1.0	1.5	2.0	3.0	7.5	7.5
Torque at max. outlet pressure	Nm	4.4	6.7	8.1	12.4	25.6	31.7
	lbf-ft	3.2	4.9	6.0	9.2	18.9	23.4
Media temperature	°C	2-50	2-50	2-50	2-50	2-50	2-50
	°F	37-122	37-122	37-122	37-122	37-122	37-122
Ambient temperature	°C	0-50	0-50	0-50	0-50	0-50	0-50
	°F	32-122	32-122	32-122	32-122	32-122	32-122
Sound pressure level ²⁾	dB(A)	76	76	76	76	75	75
Weight	kg	4.4	4.4	4.4	4.4	7.7	7.7
	lbs	9.7	9.7	9.7	9.7	17.0	17.0

¹⁾ 1% per minute peak, 10% per minute during start up.

²⁾ Measurements according to EN ISO 3744: 2010 / dB(A) [L_{PA,1m}] values are calculated. Measured at max pressure and rpm for a motor pump unit.

4.2 PAHT 20-32

Pump size		20	25	32
Code number PAHT		180B0019	180B0020	180B0021
Housing material		AISI 316 or higher	AISI 316 or higher	AISI 316 or higher
Geometric displacement	cm ³ /rev	20	25	32
	in ³ /rev	1.22	1.53	1.95
Pressure				
Min. outlet pressure	barg	30	30	30
	psig	435	435	435
Max. outlet pressure	barg	100	160	160
	psig	1450	2321	2321
Inlet pressure, continuous ¹⁾	barg	0-6	0-6	0-6
	psig	0-87	0-87	0-87
Max. inlet pressure, peak ²⁾	barg	20	20	20
	psig	290	290	290
Speed				
Min. speed	rpm	700	700	700
Min. speed, continuous	rpm	1000	1000	1000
Max. speed	rpm	2400	2400	2400
Typical flow - Flow curves available in section 5				
1000 rpm at max pressure	l/min	16.9	20.6	28.0
1500 rpm at max pressure	l/min	27.0	33.2	44.2
1200 rpm at max. pressure	gpm	5.4	6.7	9.0
1800 rpm at max. pressure	gpm	8.6	10.6	14.0
Typical motor size				
1500 rpm at max. pressure	kW 50Hz	5.5	11.0	15.0
1800 rpm at max. pressure	hp 60Hz	7.5	20.0	20.0
Torque at max. outlet pressure	Nm	21.0	69.2	89.0
	lbf-ft	15.5	51.1	65.7
Media temperature	°C	2-50	2-50	2-50
	°F	37-122	37-122	37-122
Ambient temperature	°C	0-50	0-50	0-50
	°F	32-122	32-122	32-122
Sound pressure level ³⁾	dB(A)	79	79	79
Weight	kg	19	19	19
	lbs	42	42	42

¹⁾ Above 1800 rpm inlet pressure 2-6 barg

²⁾ 1% per minute peak, 10% per minute during start up.

³⁾ Measurements according to EN ISO 3744: 2010 / dB(A) [L_{PA, 1m}] values are calculated. Measured at max pressure and rpm for a motor pump unit.

4.3 PAHT 50-90

Pump size		50	63	70	80	90
Code number PAHT		180B0085	180B0086	180B0087	180B0088	180B0089
Housing material		AISI 316 or higher	AISI 316 or higher	AISI 316 or higher	AISI 316 or higher	AISI 316 or higher
Geometric displacement	cm ³ /rev	50	63	70	80	90
	in ³ /rev	3.05	3.84	4.27	4.88	5.49
Pressure						
Min. outlet pressure	barg	30	30	30	30	30
	psig	435	435	435	435	435
Max. outlet pressure	barg	80	160	160	160	160
	psig	1160	2321	2321	2321	2321
Inlet pressure, continuous	barg	0-6	0-6	0-6	0-6	0-6
	psig	0-87	0-87	0-87	0-87	0-87
Max. inlet ¹⁾ pressure, peak	barg	20	20	20	20	20
	psig	290	290	290	290	290
Speed						
Min. speed	rpm	700	700	700	700	700
Min. speed, continuous	rpm	1000	1000	1000	1000	1000
Max. speed	rpm	1800	1800	1800	1800	1800
Typical flow - Flow curves available in section 5						
1000 rpm at max. pressure	l/min	43.7	50.5	57.7	68.3	77.6
1500 rpm at max. pressure	l/min	68.7	82.1	92.9	108.5	122.6
1200 rpm at max. pressure	gpm	14.0	16.4	18.7	21.9	24.9
1800 rpm at max. pressure	gpm	21.8	26.3	29.6	34.5	38.9
Typical motor size						
1500 rpm at max. pressure	kW 50 Hz	11	30	30	37	45
1800 rpm at max. pressure	hp 60 Hz	20	50	50	60	75
Torque at max. outlet pressure	Nm	68.5	172.6	191.8	219.8	246.6
	lbf-ft	50.6	127.4	141.5	162.2	182.0
Media temperature	°C	2-50	2-50	2-50	2-50	2-50
	°F	37-122	37-122	37-122	37-122	37-122
Ambient temperature	°C	0-50	0-50	0-50	0-50	0-50
	°F	32-122	32-122	32-122	32-122	32-122
Sound pressure level ²⁾	dB(A)	80	80	80	80	81
Weight	kg	34	34	34	34	34
	lbs	75	75	75	75	75

¹⁾ 1% per minute peak, 10% per minute during start up.

²⁾ Measurements according to EN ISO 3744: 2010 / dB(A) [L_{pA,1m}] values are calculated. Measured at max pressure and rpm for a motor pump unit.

4.4 PAHT 256-308

Pump size		256	308
Code number PAHT		180B1001	180B1002
Housing material		AISI 316 or higher	AISI 316 or higher
Geometric displacement	cm ³ /rev	256	308
	in ³ /rev	15.6	18.8
Pressure			
Min. outlet pressure	barg	30	30
	psig	435	435
Max. outlet pressure	barg	120	120
	psig	1740	1740
Inlet pressure, continuous	barg	2-6	2-6
	psig	29-87	29-87
Max inlet pressure, peak ¹⁾	barg	10	10
	psig	145	145
Speed			
Min. speed	rpm	450	450
Min. speed, continuous	rpm	700	700
Max. speed	rpm	1250	1250
Typical flow - Flow curves available in section 5			
450 rpm at max. pressure	l/min	89.6	107.8
1250 rpm at max. pressure	l/min	294.4	354.2
450 rpm at max. pressure	gpm	23.3	28.0
1250 rpm at max. pressure	gpm	76.5	92.1
Typical motor size			
1000 rpm at max. pressure	kW 50 Hz	55	75
1200 rpm at max. pressure	hp 60 Hz	100	125
Torque at max. outlet pressure	Nm	549.6	661.3
	lbf-ft	405.6	448.0
Media temperature	°C	2-50	2-50
	°F	37-122	37-122
Ambient temperature	°C	0-50	0-50
	°F	32-122	32-122
Sound pressure level ²⁾	dB(A)	82	87
Weight	kg	105	105
	lbs	231	231

¹⁾ 1% per minute peak, 10% per minute during start up.

²⁾ Measurements according to EN ISO 3744: 2010 / dB(A) [L_{PA, 1m}] values are calculated. Measured at max pressure and rpm for a motor pump unit.

5. Flow

The flow (Q_{eff}) at various pressure (p_{max}) can be calculated with the following equation:

$$Q_{eff} = Q_{(th)} - [(Q_{(th)} - Q(p_{max})) \times (p / p_{max})]$$

The theoretical flow can be calculated with the following equation:

$$Q_{(th)} = \frac{V \times n}{1000}$$

At zero pressure the true flow equals the theoretical flow $Q_{(th)}$.

$Q_{(th)}$:	Theoretical flow (l/min / gpm)
$Q(p_{max})$:	Flows at max. pressure (l/min and gpm), see 4.1-4.4
p_{max} :	Max pressure (barg / psig)
p :	Pressure (barg / psig)
V :	Displacement ($cm^3 / rev.$)
n :	Motor speed (rpm)

5.1 PAHT 2-6.3 typical flow curves at max pressure

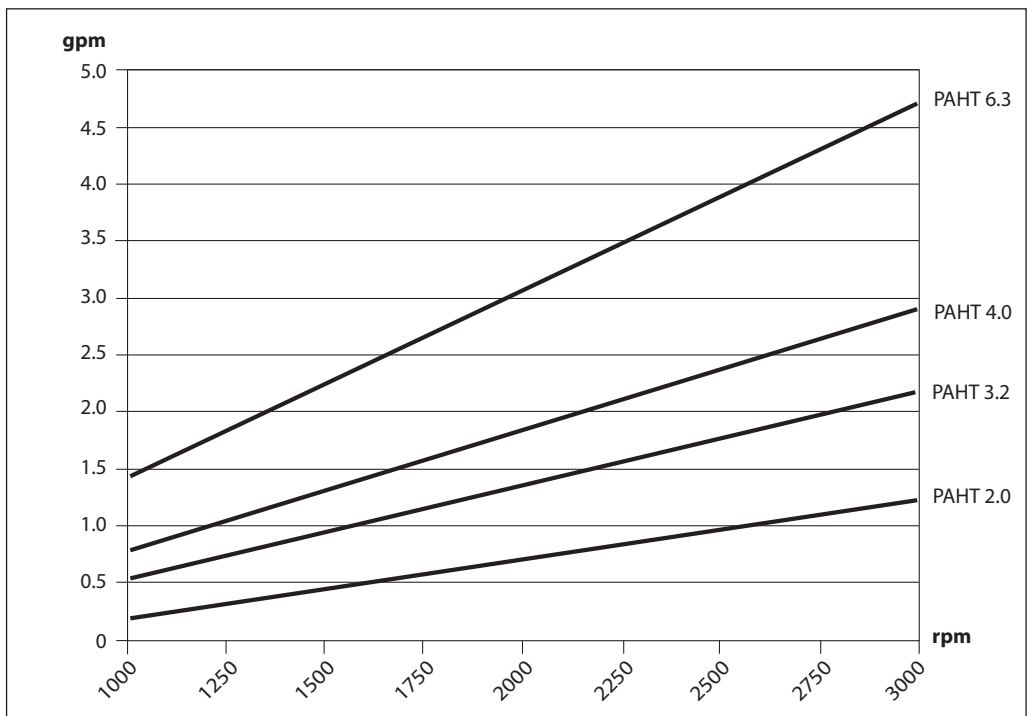
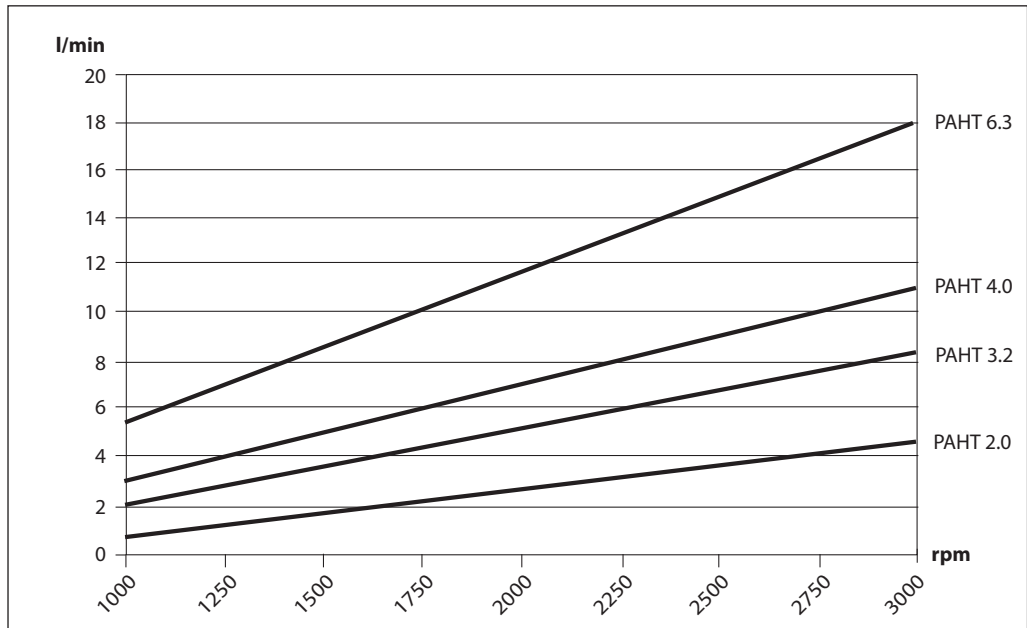

5.2 PAHT 10-12.5 typical flow curves at max pressure

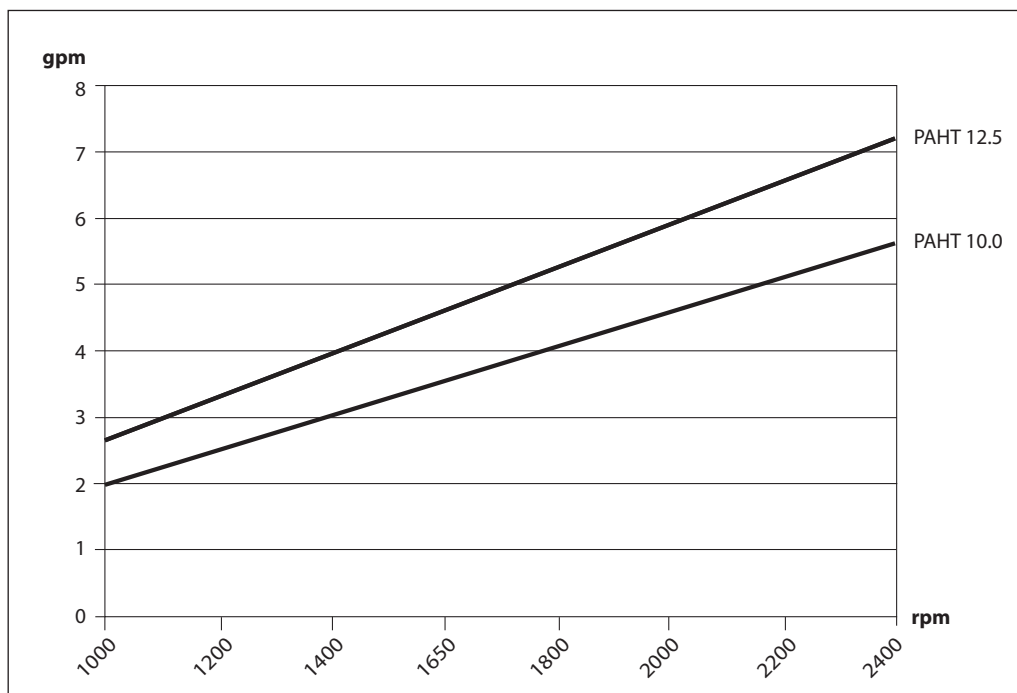
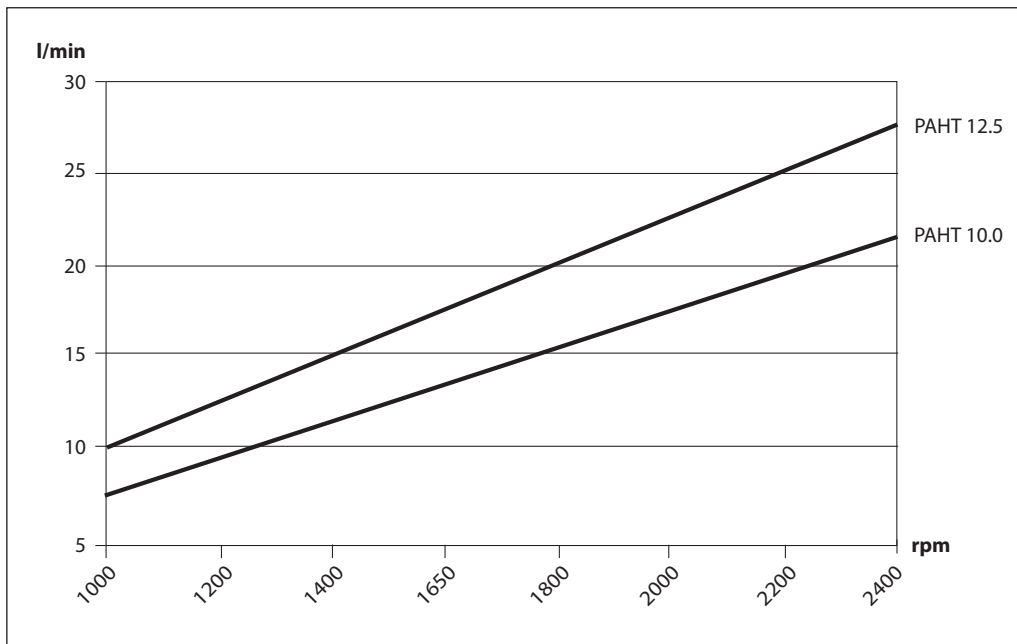

5.3 PAHT 20-32 typical flow curves at max pressure

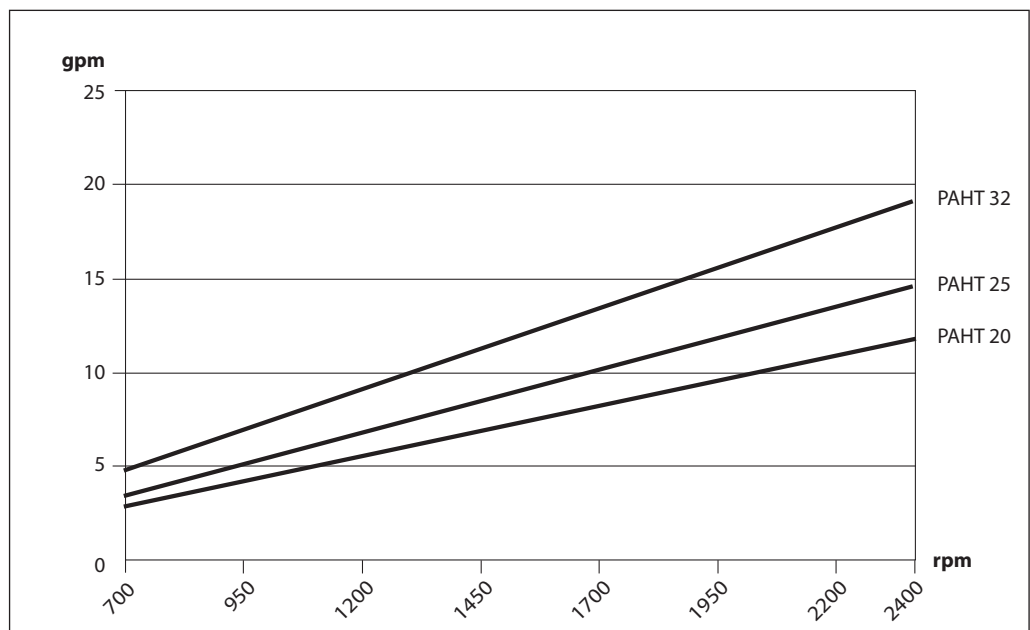
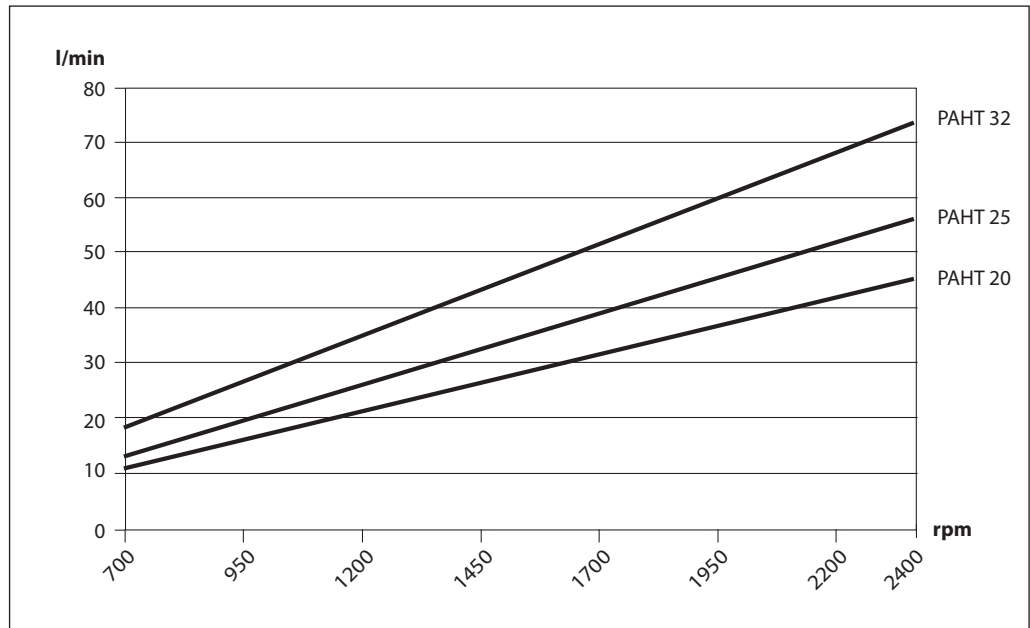

5.4 PAHT 50-90 typical flow curves at max pressure

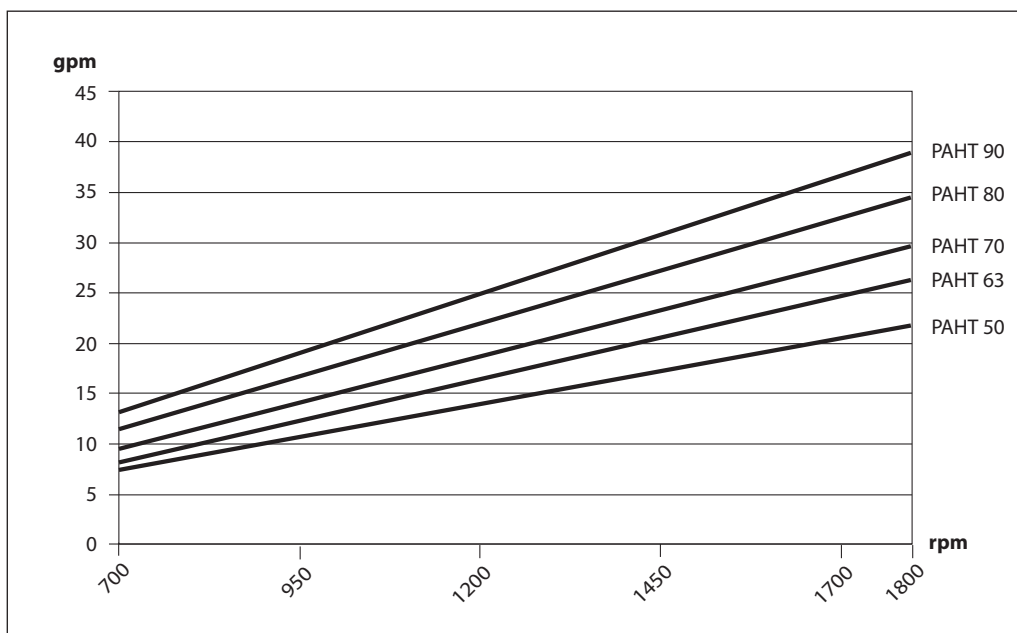
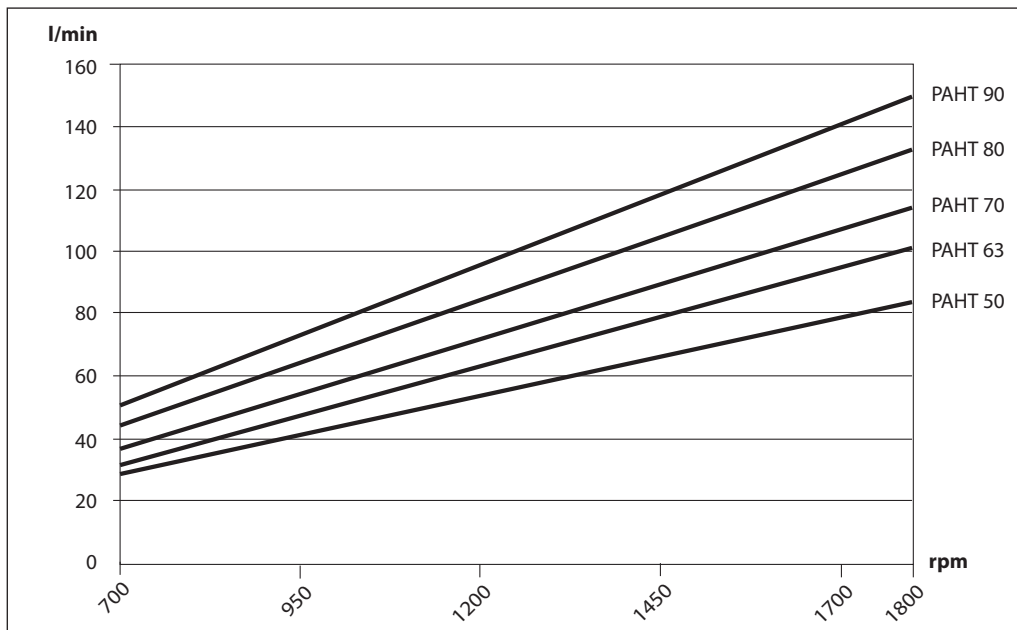

5.5 PAHT 256-308 typical flow curves at max pressure

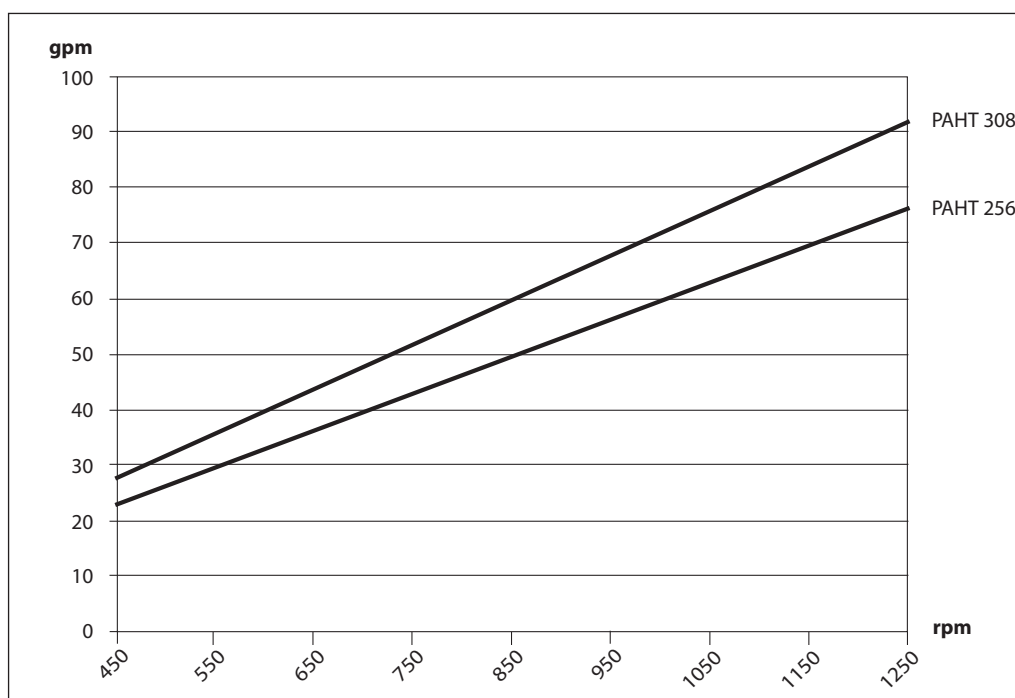
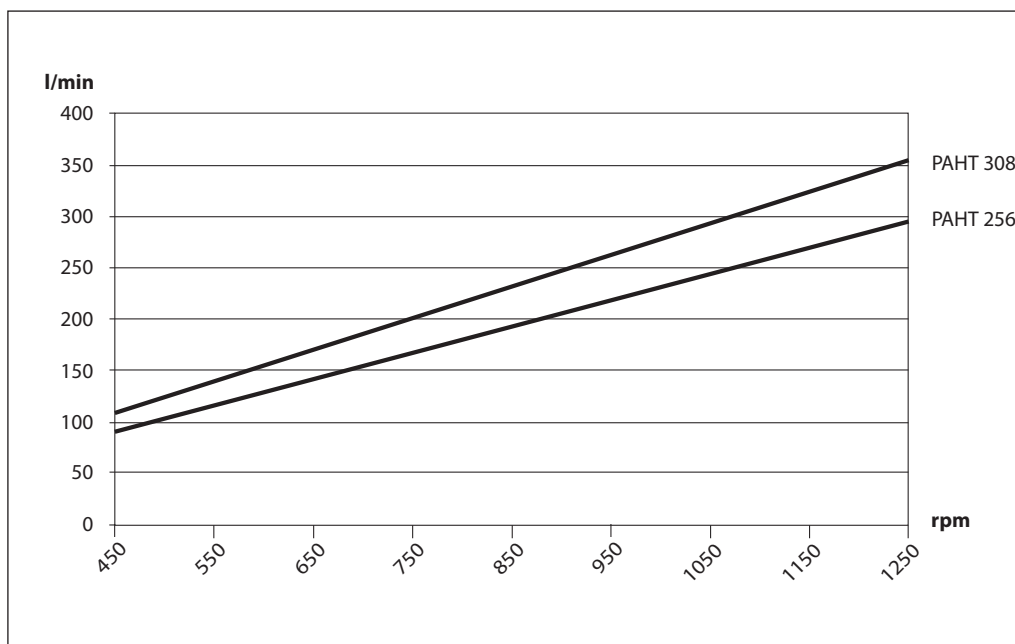

6. Motor requirements

The required motor power can be calculated by using the following equation:

$$P = \frac{n \times V \times p}{600.000 \times \eta}$$

P: Power (kW)
 M: Torque (Nm)
 η: Mechanical efficiency
 p: Pressure (barg)
 n: Motor speed (rpm)
 V: Displacement (cm³/rev.)

From the flow curves in item 5, you can determine the rpm of the pump at the desired flow.

The required torque is calculated as follows:

$$M = \frac{V \times p}{62.8 \times \eta}$$

To determine the correct motor size, both the power and torque requirement must be verified.

The mechanical efficiency of the pump, at max pressure, is as follows:

PAHT 2, 3.2, 4, 6.3	0.8
PAHT 10, 12.5	0.9
PAHT 20, 25, 32, 50, 63, 70, 80, 90	0.95
PAHT 256, 308	0.95

7. Installation

See the figure below for instructions on how to mount the pump and connect it to an electric

motor or combustion engine.

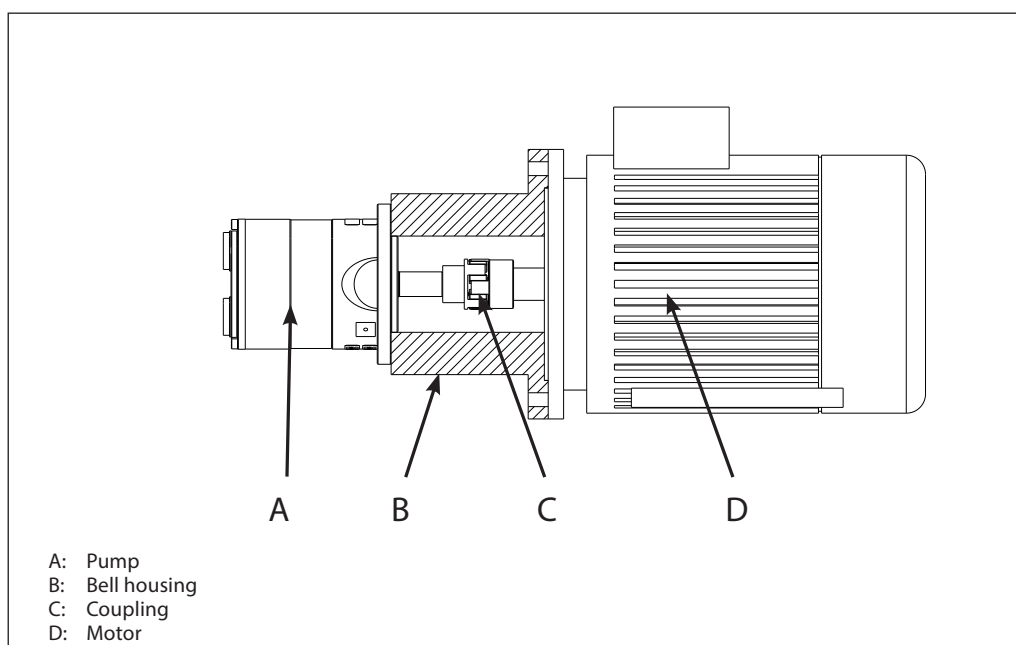

If alternative mounting is required, please contact your Danfoss sales representative for further information.

For more information on the importance of proper filtration, including explanation of filtration principles, definitions, and guidance on how to select the right filter for your pump, please consult our **Filtration** information and specifications (Danfoss document number 521B1009).

Note: Do not add any axial or radial loads to the pump shaft.

7.1 Filtration

Proper filtration is crucial for the performance, maintenance and warranty of your pump.

Protect your pump, and the application in which it is installed, by always ensuring that filtration specifications are met, and by always changing filter cartridges according to schedule.

Since water has very low viscosity, Danfoss PAHT pumps have been designed with very narrow clearances in order to control internal leakage rates and improve component performance. **To minimize wear on the pump, it is therefore essential to filter inlet water properly.**

The main filter must have a filtration efficiency of 99.98% at 10 µm. We strongly recommend that you always use precision depth filter cartridges rated 10 µm abs. $\beta_{10} \geq 5,000$.

Please note that **we do not recommend bag filters or string-wound filter cartridges**, which typically have only 50% filtration efficiency. This means that out of 100,000 particles that enter such filters, 50,000 particles pass right through them; compare this to precision depth filters that are 99.98% efficient, and only allow 20 of the same 100,000 particles to pass through.

7.2 Noise

Since the pump unit is mounted on a frame, the overall noise level can only be determined for a complete system. To minimize vibrations and noise throughout the system, it is therefore very important to mount the pump unit correctly on a frame with dampers and to use flexible hoses rather than metal pipes where possible.

The noise level is influenced by:

- **Pump speed:**
High rpm makes more fluid/structure-borne pulsations/vibrations than low rpm.
- **Discharge pressure:**
High pressures make more noise than low pressures.
- **Pump mounting:**
Rigid mounting makes more noise than flexible mounting because of the structure-borne vibrations. Be sure to use dampers when mounting.
- **Connections to pump:**
Pipes connected directly to the pump make more noise than flexible hoses because of structure-borne vibrations.
- **Variable frequency drives (VFDs):**
Motors regulated by VFDs can produce more noise if the VFD does not have the right settings.

7.3 Open-system design

- A Inlet line:**
Dimension the inlet line to obtain minimum pressure loss (large flow, minimum pipe length, minimum number of bends/connections, fittings with small pressure losses and restrictions).
- B Inlet filter:**
Install the inlet filter (1) in front of the PAHT pump (2). Please consult the Danfoss filter data sheet for guidance on how to select the right filter.
- C Monitoring pressure switch:**
Install the monitoring pressure switch (3) between the filter and the pump inlet. Set the minimum inlet pressure according to specifications described in item 4, technical data. The monitoring pressure switch stops the pump if inlet pressure is lower than the set minimum pressure.
- D Monitoring temperature switch:**
Install the monitoring temperature switch (4) between the filter and the pump, on either side of the monitoring pressure switch. Set the temperature value according to technical data, item 4. The monitoring temperature switch stops the pump if

- inlet temperature is higher than the set value.
- E Hoses:**
Always use flexible hoses (5) to minimize vibrations and noise.
- F Inlet pressure:**
In order to eliminate the risk of cavitation and other pump damage, pump inlet pressure must be maintained according to specifications described in item 4, technical data.
- G Non-return valve (6):**
Should be installed after the outlet to prevent pump backspin, which may ruin the pump.
- H Pressure relief valve:**
As the Danfoss PAHT pump begins to create pressure and flow immediately after start-up regardless of any counter pressure, a pressure relief valve (7) should be installed to prevent system damage.

Note: If a non-return valve is mounted in the inlet line, a low-pressure relief valve is also recommended between the non-return valve (8) and the pump to protect against high-pressure peaks.

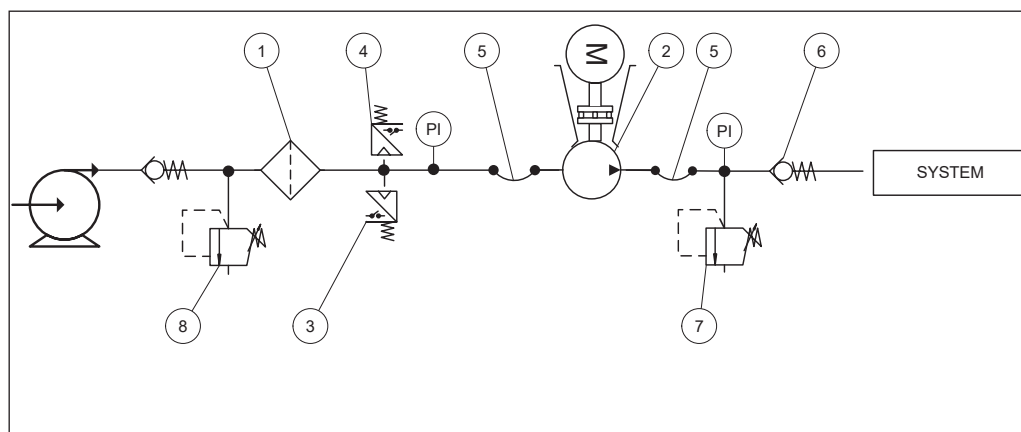

7.4 Closed-system design (not applicable for PAHT 256-308)

- A Inlet line:**
Dimension the inlet line to obtain minimum pressure loss (large flow, minimum pipe length, minimum number of bends/connections, fittings with small pressure losses and restrictions).
- B Inlet filter:**
Install the filter (1) in front of the tank (2). Please consult the Danfoss filter data sheet for guidance on how to select the right filter.
- C Monitoring pressure switch:**
Install the monitoring pressure switch (3) in front of the filter (1). Set the maximum inlet pressure to 2 barg (29.0 psig). The monitoring pressure switch will stop the pump (5) if inlet pressure is higher than 2 barg (29.0 psig), indicating that the filter element must be changed.
- D Monitoring temperature switch:**
Install the monitoring temperature switch (4) in the tank. Set the temperature value according to technical data, item 4. The monitoring temperature stops the pump if inlet temperature is higher than the set value.
- E Hoses:**
Always use flexible hoses (6) to minimize vibrations and noise.
- F Inlet pressure:**
In order to eliminate the risk of cavitation and other pump damage, pump inlet pressure must be maintained according to specifications described in item 4, technical data.
- G Non-return valve (7):**
Should be installed after the outlet to prevent pump backspin, which may ruin the pump.
- H Pressure relief valve:**
As the Danfoss PAHT pump begins to create pressure and flow immediately after start-up regardless of any counter pressure, a pressure relief valve (8) should be installed to prevent system damage.
- I System water filling:**
To ensure proper filtration of new water (10) supplied to the system, always use the filling valve (9).
- J Minimum level switch:**
Install the minimum level switch (11) above the outlet of the reservoir. The level switch must stop the pump if the water in the reservoir is below the switch, which indicates that the reservoir is empty.

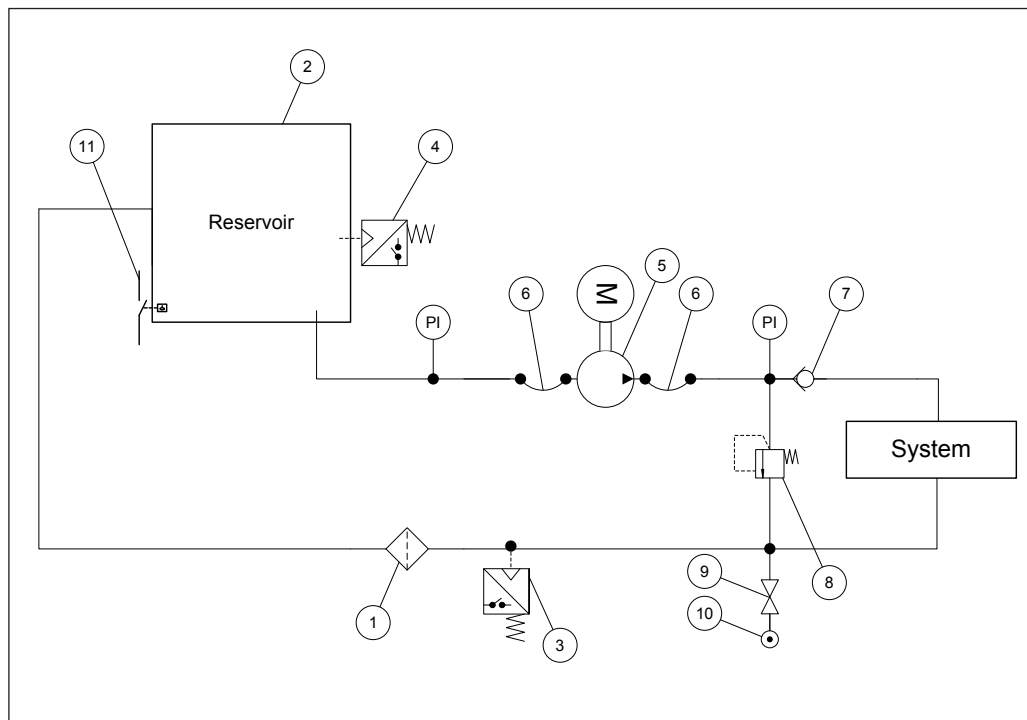

8. Dimensions and connections

8.1 PAHT 2-6.3

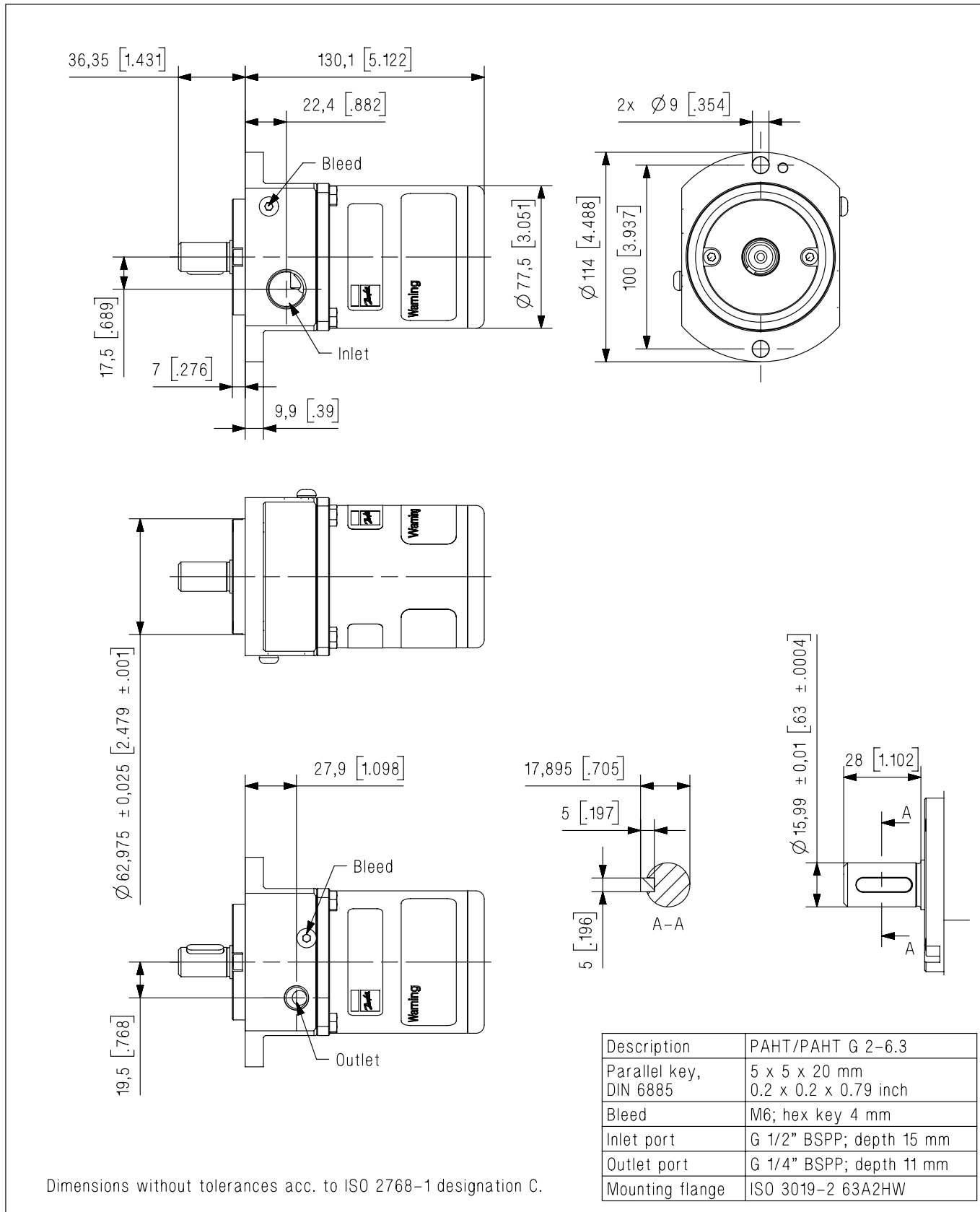

8.2 PAHT 10-12.5

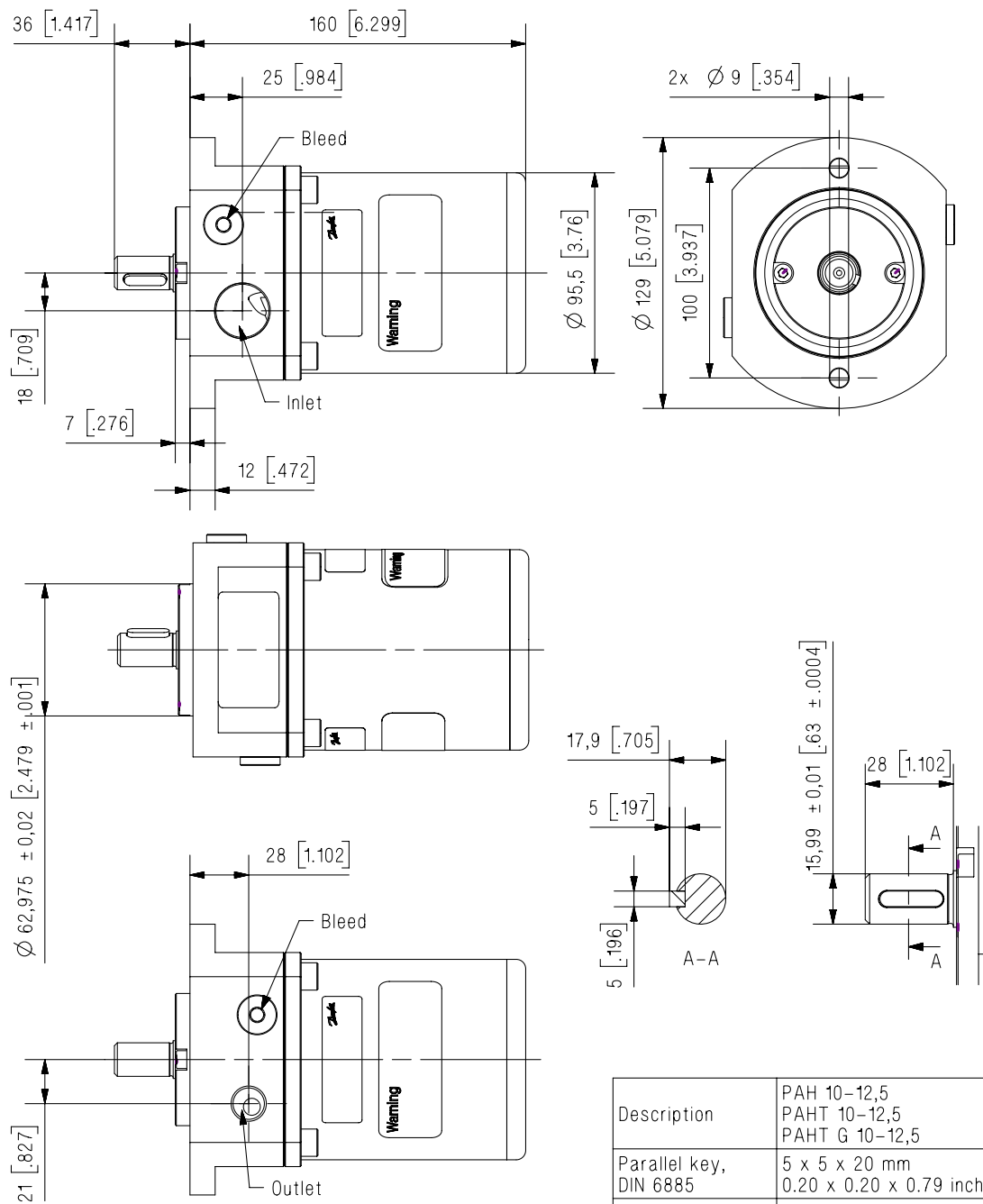

Dimensions without tolerances acc. to ISO 2768-1 designation C.

Description	PAH 10-12,5 PAHT 10-12,5 PAHT G 10-12,5
Parallel key, DIN 6885	5 x 5 x 20 mm 0.20 x 0.20 x 0.79 inch
Bleed	G 1/4" BSPP; hex key 6 mm
Inlet port	G 3/4" BSPP; depth 17 mm
Outlet port	G 3/8" BSPP; depth 15 mm
Mounting flange	ISO 3019-2 63A2HW

8.3 PAHT 20-32

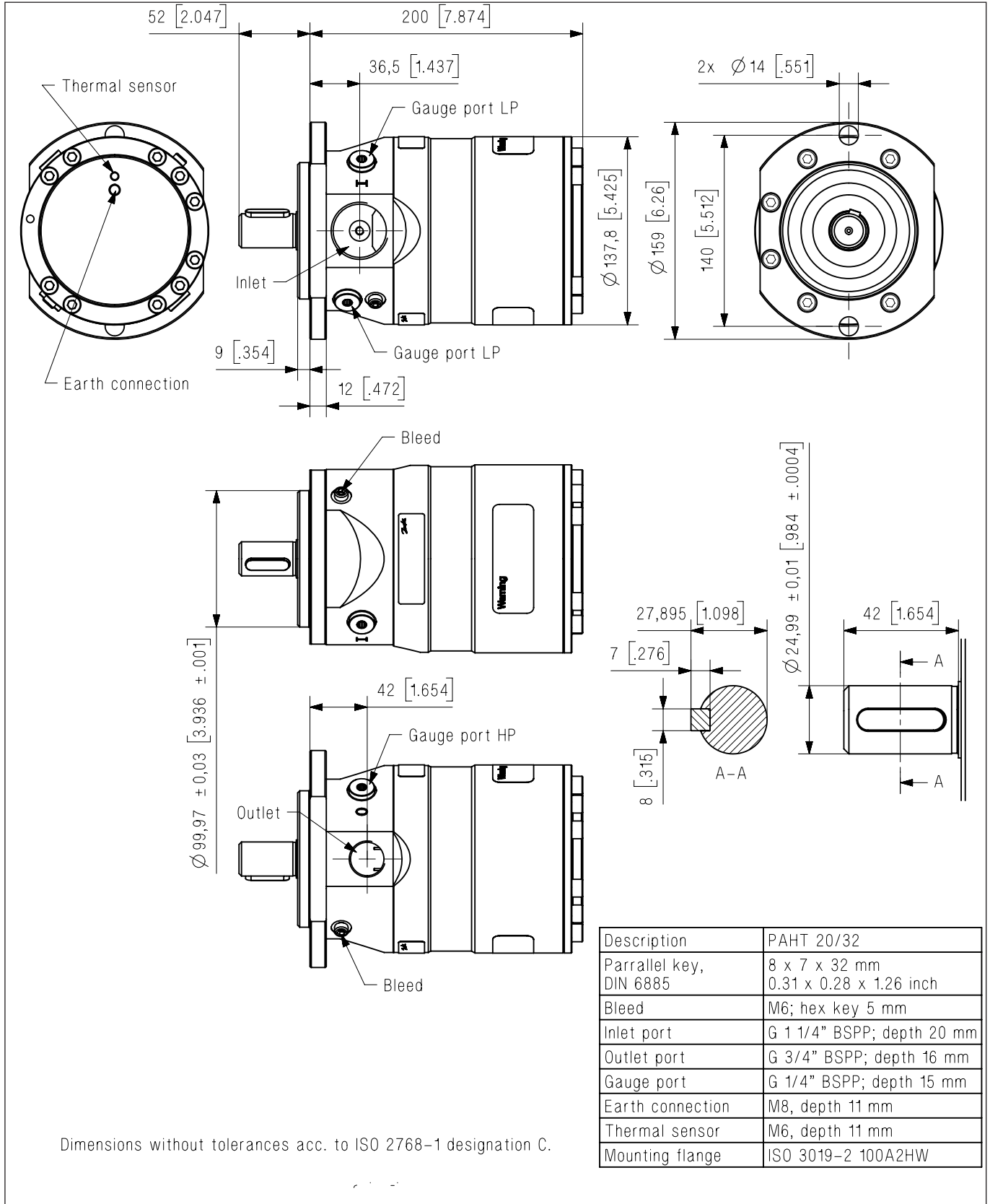

Description	PAHT 20/32
Parallel key, DIN 6885	8 x 7 x 32 mm 0.31 x 0.28 x 1.26 inch
Bleed	M6; hex key 5 mm
Inlet port	G 1 1/4" BSPP; depth 20 mm
Outlet port	G 3/4" BSPP; depth 16 mm
Gauge port	G 1/4" BSPP; depth 15 mm
Earth connection	M8, depth 11 mm
Thermal sensor	M6, depth 11 mm
Mounting flange	ISO 3019-2 100A2HW

8.4 PAHT 50-90

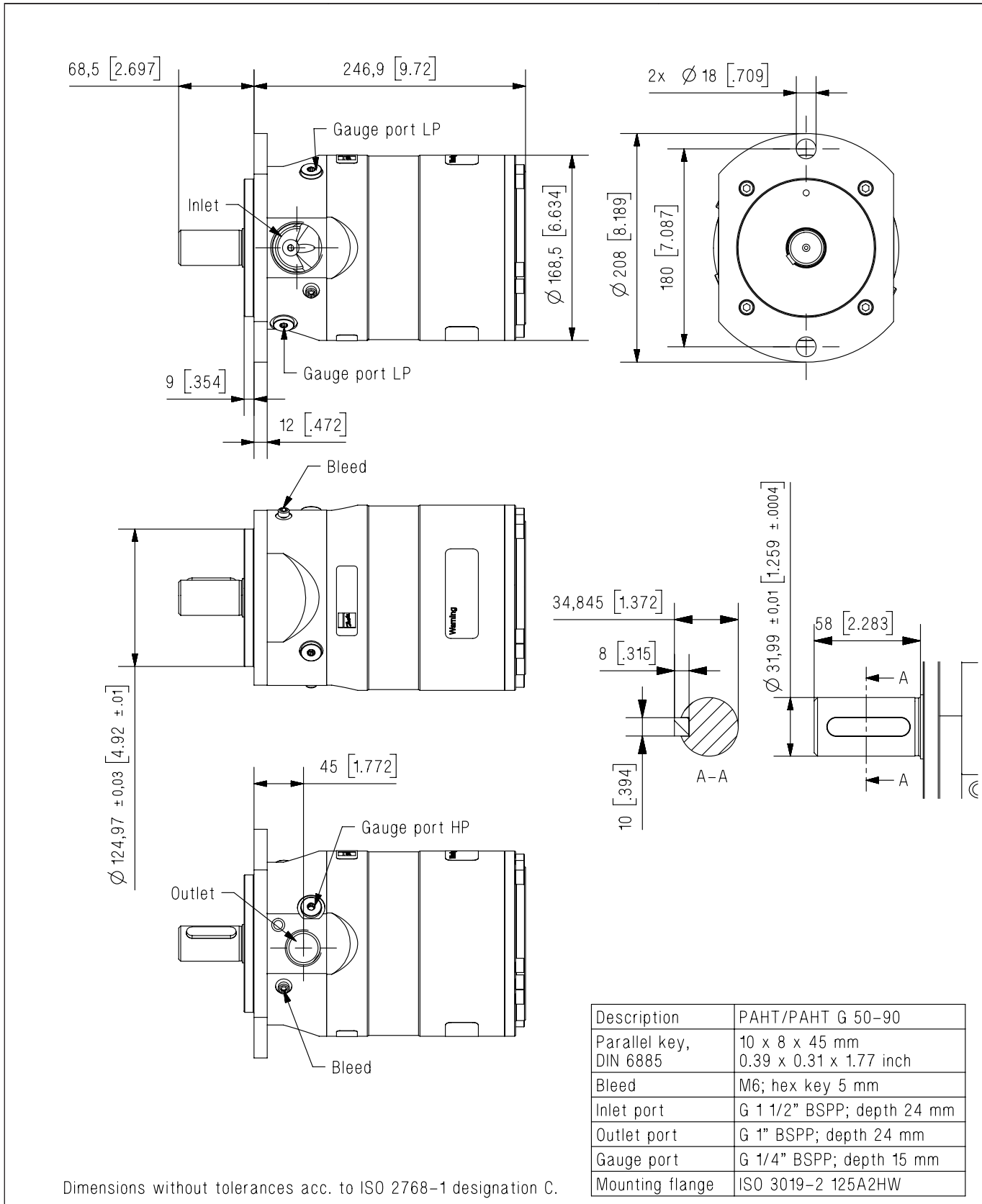

8.5 PAHT 256-308

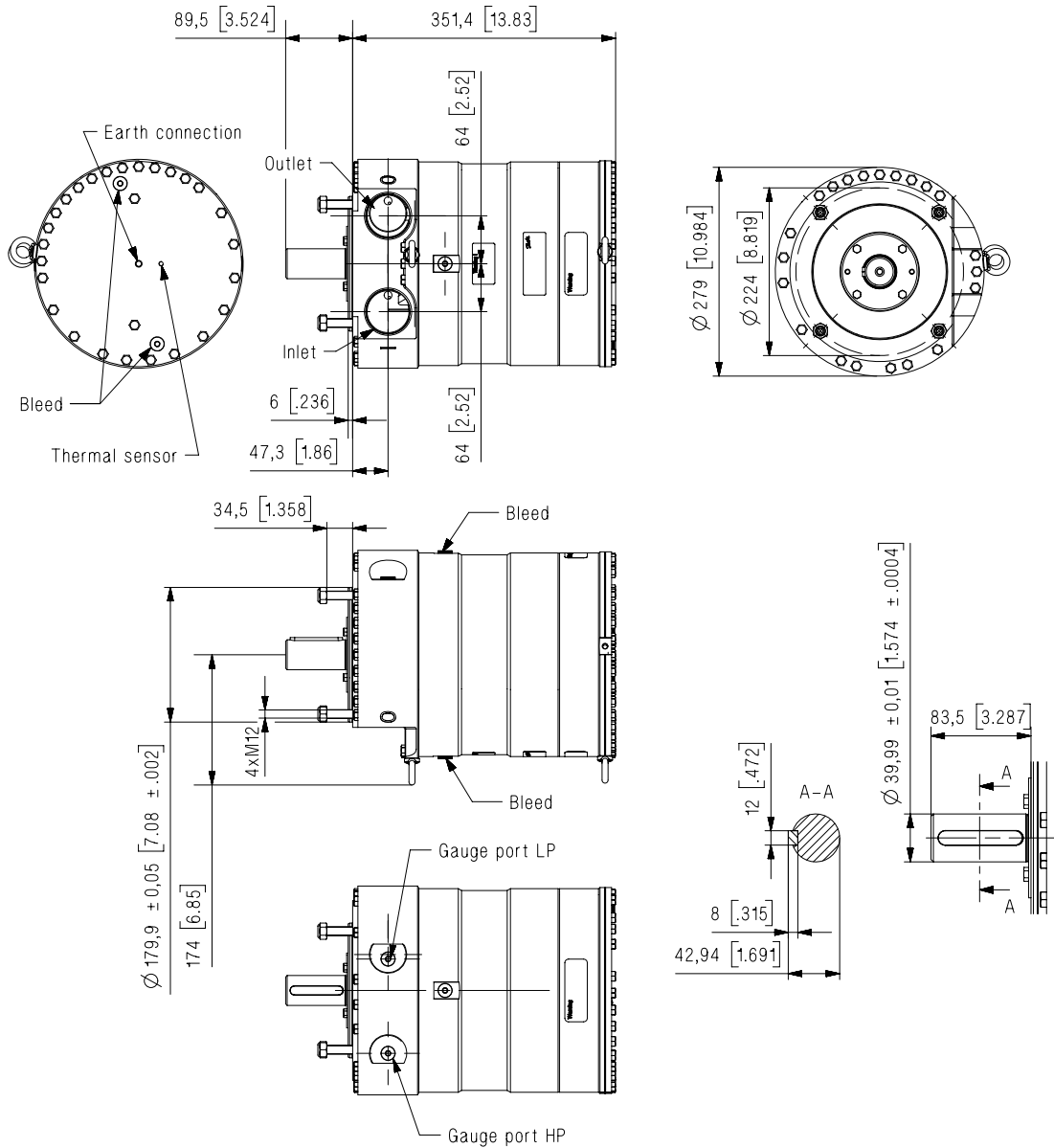

Dimensions without tolerances acc. to ISO 2768-1 designation C.

Description	PAHT/PAHT G 256-308
Parallel key, DIN 6885	12 x 8 x 70 mm 0.47 x 0.31 x 2.76 inch
Bleed	G 1/4"; hex key 6 mm
Inlet port	M60 x 1.5 depth 24 mm
Outlet port	M60 x 1.5 depth 24 mm
Gauge port	G 1/4" BSPP; depth 12 mm
Earth connection	M8, depth 11 mm
Thermal sensor	M6, depth 11 mm
Mounting flange	ISO 3019-2 180B4TW

9. Service

Danfoss PAHT pumps are designed for long periods of service-free operation to ensure low maintenance and life cycle costs. Provided that the pump is installed and operated according to Danfoss specifications, Danfoss PAHT pumps typically run 8,000 hours between service. However, the service schedule for your Danfoss PAHT pump may vary according to the application and other factors.

The life of a pump may be greatly shortened if Danfoss recommendations concerning system design and operation are not followed.

In our experience, poor filtration is the number one cause of pump damage.

Other factors that affect pump performance and lifetime include:

- running the pump at speeds outside specifications
- supplying the pump with water at temperatures higher than recommended
- running the pump at inlet pressures outside specifications
- running the pump at outlet pressures outside the specifications.

We recommend that you inspect your pump after 8,000 hours of operation even if it is running without any noticeable problems. Replace any worn parts if necessary, including pistons and shaft seals, to keep your pump running efficiently and to prevent breakdown. If worn parts are not replaced, then our guidelines recommend more frequent inspection.

If the recommendations in the manual are not followed, Danfoss reserves the right to void the warranty.



Danfoss A/S

High Pressure Pumps • danfoss.com • +45 7488 2222 • highpressurepumps@danfoss.com

Any information, including, but not limited to information on selection of product, its application or use, product design, weight, dimensions, capacity or any other technical data in product manuals, catalogues descriptions, advertisements, etc. and whether made available in writing, orally, electronically, online or via download, shall be considered informative, and is only binding if and to the extent, explicit reference is made in a quotation or order confirmation. Danfoss cannot accept any responsibility for possible errors in catalogues, brochures, videos and other material. Danfoss reserves the right to alter its products without notice. This also applies to products ordered but not delivered provided that such alterations can be made without changes to form, fit or function of the product.

All trademarks in this material are property of Danfoss A/S or Danfoss group companies. Danfoss and the Danfoss logo are trademarks of Danfoss A/S. All rights reserved.