



Installation guide

CETOP 3 Directional Control Valve

VDHT 30 EC 2/2

180R9051

Identifikation
Identification
Kennzeichnung
Identification

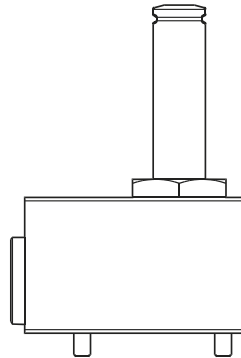

2/2 Directional Valve

Type VDHT 30EC 2/2
Code no. 180LXXXX
Serial no. XXXXXXXXX



MADE IN DENMARK



Danfoss A/S, 6430 Nordborg, Denmark

180R9051

Montage

Ventilen monteres på en blok med CETOP 3 port billede. Til montage af ventilen anvendes de medleverede 4 rustfrie stålskruer og de 4 O-ringe. Husk at smøre/spraye gevindene på skrueerne med f.eks. Molykote® D pasta fra Dow Corning, eller Klüber UH1 84-201 fra Klüber lubrication, inden disse monteres.

Installation

The valve is designed to be mounted on a block with CETOP 3-port connection. Four stainless steel screws and four O-rings are supplied with the valve for mounting. Remember to smear/spray the threads on the screws with Molykote® D pasta from Dow Corning, or Klüber UH1 84-201 from Klüber lubrication, before mounting the valve.

Montage

Das Ventil wird auf einen Block mit der CETOP 3 Port-Kennzeichnung montiert. Zur Montage des Ventils sind die 4 mitgelieferten Edelstahlschrauben und die 4 O-Ringe zu verwenden. Bitte nicht vergessen, die Schraubengewinde vor der Montage mit z.B. Molykote® D pasta von Dow Corning, oder Klüber UH1 84-201 von Klüber lubrication, zu schmieren/einzusprühen.

Montage

Monter le distributeur sur une unité CETOP 3 à l'aide des 4 vis en acier inoxydable et des 4 joints toriques fournis. Avant de monter les vis, ne pas oublier de passer/vaporiser un lubrifiant, de type Molykote® D pasta de Dow Corning, ou Klüber UH1 84-201 de Klüber lubrication, sur le filetage.

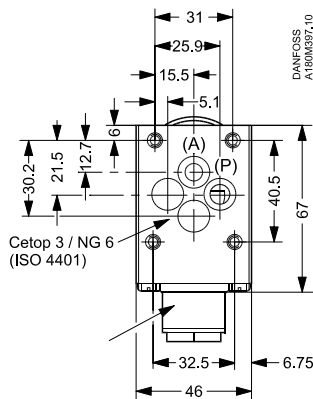

Max. tilspændingsmoment for M 5×40: 7 Nm (60 lbs in)
 Max. tightening torque M 5×40: 7 Nm (60 lbs in)
 Max. Anzugsmoment für M 5×40: 7 Nm (60 lbs in)
 Couple max. de serrage M 5×40: 7 Nm (60 lbs in)

Montage af spoler

Installation of coils

Montage von Spulen

Installation les bobines

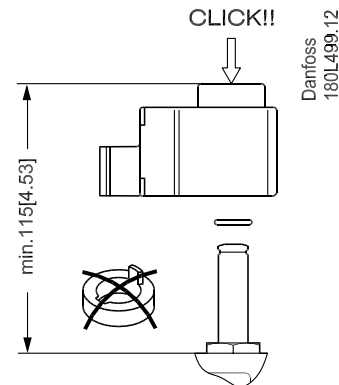

Filtrering

Mediet skal friholdes så vidt muligt for snavs og andre partikler. For at opnå den bedst mulige levetid, anbefales det at man placerer et filter eller en si foran ventilen.

Filter

Keep the medium as free from dirt and foreign particles as possible. To obtain the best possible service life, it is recommendable to place a filter or a strainer before the valve.

Filter

Das Medium muss so weit möglich von Unreinheiten und anderen Fremdkörpern frei gehalten werden. Um die best mögliche Lebensdauer zu erzielen wird empfohlen, ein Filter oder ein Sieb vor dem Ventil zu installieren.

Filtre

Le fluide doit être maintenu aussi propre que possible et libre de particules étrangères. Pour obtenir une durée de vie optimale, il est recommandé de placer un filtre ou une crépine en amont de la vanne.

Danfoss A/S

High Pressure Pumps • danfoss.com • +45 7488 2222 • E-mail: highpressurepumps@danfoss.com

Any information, including, but not limited to information on selection of product, its application or use, product design, weight, dimensions, capacity or any other technical data in product manuals, catalogues descriptions, advertisements, etc. and whether made available in writing, orally, electronically, online or via download, shall be considered informative, and is only binding if and to the extent, explicit reference is made in a quotation or order confirmation. Danfoss cannot accept any responsibility for possible errors in catalogues, brochures, videos and other material. Danfoss reserves the right to alter its products without notice. This also applies to products ordered but not delivered provided that such alterations can be made without changes to form, fit or function of the product. All trademarks in this material are property of Danfoss A/S or Danfoss group companies. Danfoss and the Danfoss logo are trademarks of Danfoss A/S. All rights reserved.