

Installation guide

Shut-off valves

SVA-140B DN 50-100



148R9661

148R9661

Installation / Instalación / Installazione

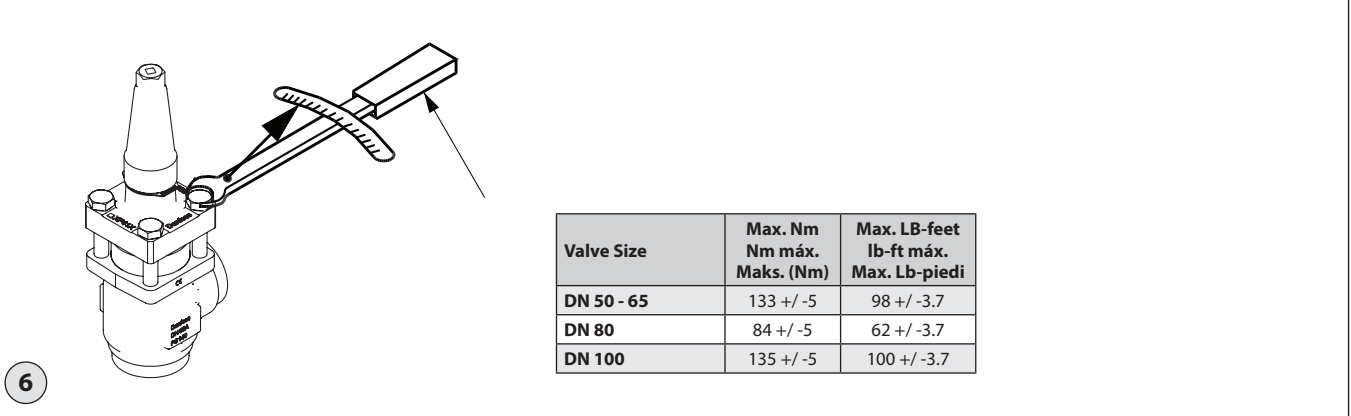
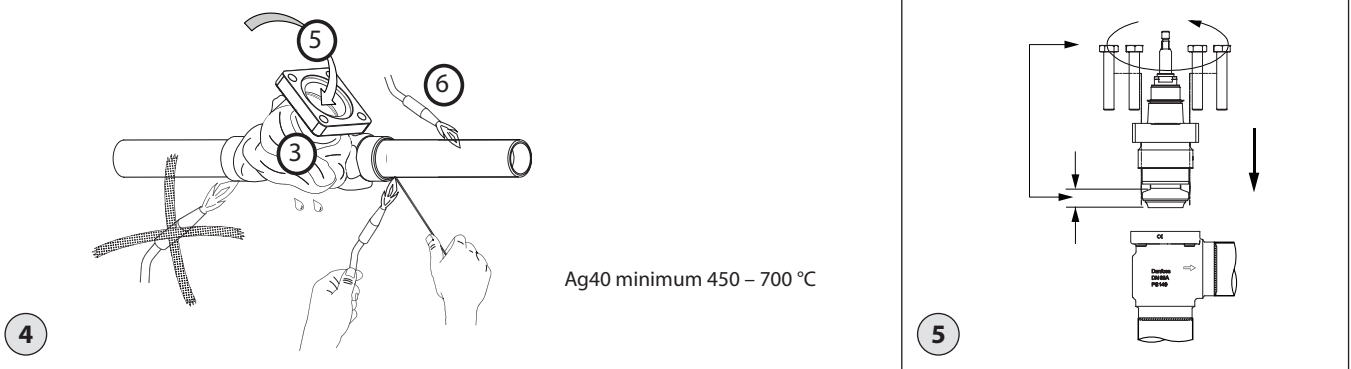
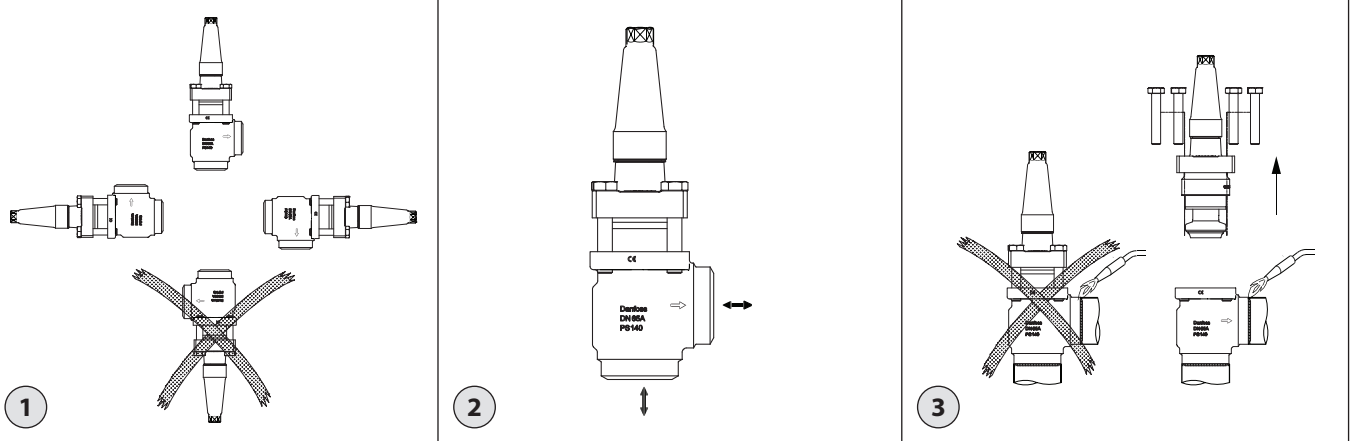

Maintenance / Wartung / Entretien / Mantenimiento / Manutenzione

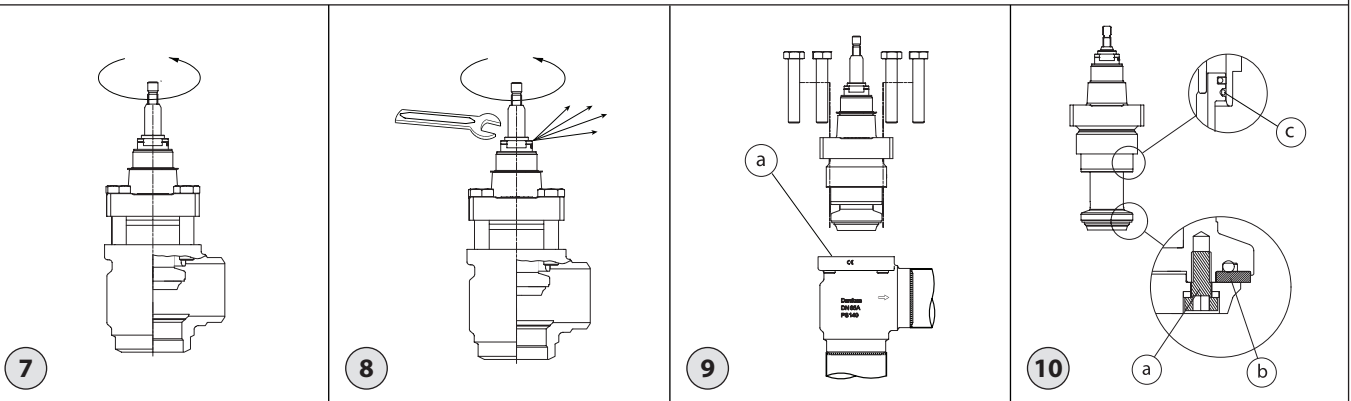

Імпортер: ТОВ з іі "Данфосс ТОВ" 04080, Київ 80, п/с 168, Україна

Info for UK customers only : Danfoss Ltd., 22 Wycombe End, HP9 1NB, GB

ENGLISH

Installation

Refrigerants

Applicable to R744 (CO₂).

The valve is only recommended for use in closed circuits. For further information please contact your local Danfoss sales office.

Pressure and temperature range

SVA-140B (DN 50-100) 140 bar (2030 psi) at -40 °C to +150 °C (-40 °F to +302 °F)

Operation

SVA are shut-off valves and must always be either fully closed or fully open. Half open positions are not allowed.

Attention!

Valves are balanced and should be operated by hand and an appropriate sized wrench. Closing the valve shall be done with a torque not higher than 40 Nm (DN50/65) 70 Nm (DN80) and 100 Nm (DN100).

Open the valve max 1 turn until the differential pressure is lower than 50 bar, then open fully.

Installation

The valve must be installed with the spindle vertically upwards or in horizontal position (fig. 1).

The valve is designed to withstand a high internal pressure. However, the piping system should be designed to avoid liquid traps and reduce the risk of hydraulic pressure caused by thermal expansion. It must be ensured that the valve is protected from pressure transients like "liquid hammer" in the system.

Recommended flow direction

To achieve optimum flow conditions, the valve should be installed with the flow towards the valve cone as indicated by the arrow on the side of the valve body (fig. 2). Flow in the opposite direction is also acceptable but reduces the K_V / C_V value approx. 10%.

Welding

The bonnet should be removed before welding (fig. 3) to prevent damage to the sealing parts in the packing gland, between the valve body and bonnet as well as between cone and valve seat. Be careful not to damage the cone sealing and make sure the complete bonnet is protected from dirt and water while removed.

Removing the bonnet can be omitted provided that: The temperature in the area between the valve body and bonnet during welding does not exceed +150 °C / + 302 °F. This temperature depends on the welding method as well as on any cooling of the valve body during the welding itself. (Cooling can be ensured by, for example, wrapping a wet cloth around the valve body.) Make sure that no dirt, welding debris etc. get into the valve during the welding procedure.

Only materials and welding methods, compatible with the valve housing material, must be used. The valve housing must be free from stresses (external loads) after installation.

The valve should be cleaned internally to remove welding debris on completion of welding and before the valve is reassembled. Avoid welding debris and dirt in the threads of the housing and the bonnet.

Do NOT remove or service the dark colored grease between the spindle thread and the bonnet. In case the grease has been contaminated with dirt, debris, particles or water

the complete top part must be replaced. Stop valves must not be mounted in systems where the outlet side of the valve is open to atmosphere. The outlet side of the valve must always be connected to the system or properly capped off, for example with a welded-on end plate.

Brazing

When brazing Danfoss recommends using Ag40 minimum 450 – 700 °C filler or better which are suitable for the working pressure and following procedure observed:

1. Remove top cover/insert
2. Clean connections with cleaning agent
3. Wrap around wet cloth (Fig. 4)
4. Apply flux on piping ends
5. Apply inert gas internal
6. Heat up piping
7. Braze with recommended brazing material and within temperature range specified
8. Remove residual flux

Assembly

Remove welding or brazing debris and any dirt from pipes and valve body before assembly. Place a flat gasket (fig. 9) in the valve house groove and place the complete top into the valve house. Be careful not to damage the cone sealing while inserting the complete top.

Tightening

Tighten the bonnet with a torque wrench, to the values indicated in the table (fig. 6). Please note that the table (fig. 6) containing maximum torque must be adhered to and **never exceeded**.

Colours and identification

The SVA valves are painted with a green oxide primer in the factory. Precise identification of the valve is made via the ID ring at the top of the bonnet, as well as by the stamping on the valve body. The external surface of the valve housing must be guarded against corrosion with a suitable protective coating after installation and assembly. Protection of the ID ring when repainting the valve is recommended.

Maintenance

Packing gland

When performing service and maintenance please observe, that the packing gland shall not be replaced. Instead, replace the complete top part, which is available as a spare part.

The packing gland can be tightened with a wrench by carefully turning it clockwise until fully tight. Tightening too much will lead to excessive wear of the packing gland and shorten the lifetime and will make the spindle movement tighter.

As a general rule, the packing gland must not be loosened to make the spindle movement easier, if there is internal pressure in the valve. However, if the following precautionary measures are taken, the packing gland can be loosened with the valve still under pressure:

Backseating (fig. 7)

To backseat the valve, turn the spindle counterclockwise until the valve is fully open and tighten with following tightening torques.

| Valve Size | Nm | Lb-ft |
|------------|----------|---------|
| DN 50/65 | 25 - 40 | 19 - 30 |
| DN 80/100 | 70 - 100 | 52 - 74 |

Pressure equalization (fig. 8)

In some cases, pressure forms behind the packing gland. The pressure can be equalized by slowly loosening the gland.

Dismantling the valve (fig. 9)

Do not remove the bonnet while the valve is still under pressure.

Before servicing the valve, isolate it from the system. Drain CO₂ e.g. to above 5,2 bara to prevent large formation of dry ice before evacuation to zero pressure. Check for refrigerant pressure before unscrewing and removing the top cover.

If the flat gasket (pos. a) or the cone sealing has been damaged, it must be replaced. Check that the spindle is free of scratches and impact marks.

Replacement of the cone sealing (fig. 10)

The cone sealing (b) can be replaced using Danfoss repair kits. Unscrew the 3 or 4 cone screws (a) with an allen key.

The cone sealing can then be removed. Place the new cone sealing on the cone. Refit with new cone screws (a) and Nord lock discs.

| Valve Size | Screw size | Nm | Lb-ft |
|------------|------------|------|-------|
| DN 50/65 | M6 | 12±1 | 9±1 |
| DN 80/100 | M8 | 29±2 | 22±2 |

Replacement of the EPDM backup O-ring

The EPDM backup O-ring can be replaced using Danfoss repair kit. This may be needed every second year, when operating constantly close to the +150 °C temperature limit.

Turn the spindle clockwise and stop when the black O-ring (c) (fig. 10) becomes visible. Remove the old O-ring and replace with a new O-ring applied with grease, to avoid damages to the O-ring when mounting.

Do NOT remove or service the dark colored grease between the spindle thread and the bonnet. In case the grease has been contaminated with dirt, debris, particles, or water the complete top part must be replaced.

Assembly

Remove welding debris and any dirt from pipes and valve body before assembly. Place a flat gasket (fig. 9) in the valve house groove and place the complete top into the valve house.

Tightening

Tighten the bonnet with a torque wrench, to the values indicated in the table (fig. 6). Please note that the table (fig. 6) containing maximum torque must be adhered to and never exceeded.

The packing gland can be tightened with a wrench by carefully turning it clockwise until the fully tight. Tightening too much will lead to excessive wear of the packing gland and shorten the lifetime and will make the spindle movement tighter.

Charging

Charge CO₂ gas to above 5,2 bara to prevent large formation of dry ice when charging with CO₂ liquid or equalizing with system pressure.

Use only original Danfoss parts, including packing glands, sealing parts and gaskets for replacement. Materials of new parts are certified for the relevant refrigerant. In cases of doubt, please contact Danfoss. Danfoss accepts no responsibility for errors and omissions. Danfoss Industrial Refrigeration reserves the right to make changes to products and specifications without prior notice.

In cases of doubt, please contact your local Danfoss sales office.

Danfoss A/S

Climate Solutions • danfoss.com • +45 7488 2222

Any information, including, but not limited to information on selection of product, its application or use, product design, weight, dimensions, capacity or any other technical data in product manuals, catalogues descriptions, advertisements, etc. and whether made available in writing, orally, electronically, online or via download, shall be considered informative, and is only binding if and to the extent, explicit reference is made in a quotation or order confirmation. Danfoss cannot accept any responsibility for possible errors in catalogues, brochures, videos and other material. Danfoss reserves the right to alter its products without notice. This also applies to products ordered but not delivered provided that such alterations can be made without changes to form, fit or function of the product.

All trademarks in this material are property of Danfoss A/S or Danfoss group companies. Danfoss and the Danfoss logo are trademarks of Danfoss A/S. All rights reserved.