



Technical brochure

# Electronically operated expansion valve for CO<sub>2</sub> Type AKVH



AKVH are electrically operated expansion valves designed for refrigerating plants using R744 refrigerant.

The AKVH valves are normally controlled by a controller from Danfoss' range of ADAP- KOOL® controllers.

The AKVH valves are supplied as a component programme, as follows:

- Separate valve
- Separate coil with terminal box or cable
- Coil with electronic controller for lower valve noise level, energy saving, higher valve MOPD and longer valve lifetime
- Spare parts in the form upper part, orifice and filter

The individual capacities are indicated with a number forming part of the type designation. The number represents the size of the orifice of the valve in question. A valve with orifice 3 will for example be designated AKVH 10-3.

The orifice assembly is replaceable.

The AKVH 10 valves cover a capacity range from 0.4 kW to 11 kW in refrigeration applications and 0.8 kW to 22 kW in freezing applications.

## Features

- For R744 refrigerant
- The valve requires no adjustment
- Wide regulation range
- Replaceable orifice assembly
- Both expansion valve and solenoid valve.
- Wide range of coils for d.c. and a.c.
- Coil with Electronic coil controller for lower valve noise level, energy saving, higher valve MOPD and longer valve lifetime.

**Approvals**

PED (97/23/EC A3.P3)

 The Low Voltage Directive 73/23/EC  
with amendments EN 60730-2-8

**Technical data  
AKVH valves**

Valve type	AKVH 10
Tolerance of coil voltage	+10 / -15%
Enclosure to IEC 529	Max. IP 67
Working principle (Pulse-width modulation)	PWM
Recommended period of time	6 Seconds
Capacity (R744)	R <sup>1)</sup> 0.4 kW to 11 kW F <sup>2)</sup> 0.8 kW to 22 kW
Regulation range (Capacity range)	10 to 100%
Connection	Solder
Evaporating temperature	- 60 to 60°C
Ambient temperature	- 50 to 50°C
Leak of valve seat	<0.02% of k <sub>v</sub> -value
MOPD	35 bar
Filter, replaceable	Internal 100 µm
Max. working pressure	AKVH10-0 to 6 PS = 90 barg <sup>3)</sup>

- 1) Refrigeration
- 2) Freezing
- 3) 90 barg under stand still conditions, but under normal operating conditions, there must be liquid to the inlet of the valve.

**Technical data  
Coil with electronic  
coil controller**

Noise level	Minimum 5 dB(a) lower noise level (mean level) when using the electronic smartconnector on a given valve
Softstart	Yes
Packing format	Single and multipack
Nominal voltage	208 - 240 VAC 50/60Hz
Power	4 W
Environment temperature	During operation: -20°C to 55°C
IP rating	IP67
Wire dimension	1 - 1.5 mm <sup>2</sup>
Approvals	CE: Low voltage and EMC directives
Neutral, phase and earth in socket	Yes

**⚠ Note!**

Coil must only be used together with electronic coil controller.

Tolerance of supply voltage: + 10 / - 15%.

## Rated capacity and Ordering

**R744**
**AKVH 10**

Valve type / orifice no.	Rated capacity kW		k <sub>v</sub> value	Connections			
	Refrigeration	Freezing	m <sup>3</sup> /h	Solder ODF			
				Industrial pack 32 valves each		Single pack 1 valve each	
				3/8 × 1/2 inch	10 × 12 mm	3/8 × 1/2 inch	10 × 12 mm
AKVH 10-0	0.4	0.8	0.003	<b>068F4068</b>	<b>068F4058</b>	<b>068F4078</b>	<b>068F4088</b>
AKVH 10-1	1.1	2.2	0.010	<b>068F4069</b>	<b>068F4059</b>	<b>068F4079</b>	<b>068F4089</b>
AKVH 10-2	1.7	3.5	0.017	<b>068F4070</b>	<b>068F4060</b>	<b>068F4080</b>	<b>068F4090</b>
AKVH 10-3	2.6	5.4	0.025	<b>068F4071</b>	<b>068F4061</b>	<b>068F4081</b>	<b>068F4091</b>
AKVH 10-4	4.3	8.7	0.046	<b>068F4072</b>	<b>068F4062</b>	<b>068F4082</b>	<b>068F4092</b>
AKVH 10-5	6.7	13.6	0.064	<b>068F4073</b>	<b>068F4063</b>	<b>068F4083</b>	<b>068F4093</b>
AKVH 10-6	10.7	21.7	0.114	<b>068F4074</b>	<b>068F4064</b>	<b>068F4084</b>	<b>068F4094</b>

**Spare parts**  
AKVH 10

Orifice no.	Code no.	Contents
0	<b>068F5283</b>	4 pc. orifice 4 pc. gasket
1		
2		
3		
4	<b>068F5284</b>	3 pc. orifice 3 pc. gasket
5		
6		

**Ordering**
*Coils for AKVH valves*

		18 bar		35 bar <sup>3)</sup>	
		AKVH /orifice no.			
		10-1 10-2 10-3 10-4 10-5	10-6	10-0 10-1 10-2 10-3 10-4 10-5	10-6
D.C. coils	Code no.				
220 V d.c. 20 W, standard with terminal box	<b>018F6851</b>	+	+	+	+
100 V d.c. 18 W, special with terminal box with DIN plugs	<b>018F6780</b>	+	+	+	-
230 V d.c. 18 W, special with terminal box with DIN plugs	<b>018F6781</b> <sup>1)</sup> <b>018F6991</b> <sup>1)</sup>	+	+	+	-
230 V d.c. 18 W, special with 2.5 m cable with 4.0 m cable with 8.0 m cable	<b>018F6288</b> <sup>1)</sup> <b>018F6278</b> <sup>1)</sup> <b>018F6279</b> <sup>1)</sup>	+	+	+	-

A.C. coils	Code no.				
115 V a.c. 10 W, 50 Hz with terminal box with DIN-plugs	<b>018F6711</b> <b>018F6186</b>	+	+	-	-
115 V a.c. 10 W, 60 Hz with terminal box with DIN-plugs	<b>018F6710</b> <b>018F6185</b>	+	+	-	-
110 V a.c. 12 W, 50 Hz with terminal box	<b>018F6811</b>	+	+	+	-
110 V a.c. 12 W, 60 Hz with terminal box	<b>018F6813</b>	+	+	-	-
24 V a.c. 10 W, 50 Hz with terminal box with DIN-plugs	<b>018F6707</b> <b>018F6182</b>	+	-	-	-
24 V a.c. 12 W, 50 Hz with terminal box	<b>018F6807</b>	+	-	-	-
24 V a.c. 12 W, 60 Hz with terminal box	<b>018F6815</b>	+	-	-	-
24 V a.c. 20 W, 50 Hz with terminal box	<b>018F6901</b> <sup>2)</sup>	+	+	+	+
24 V a.c. 20 W, 60 Hz with terminal box	<b>018F6902</b> <sup>2)</sup>	+	+	+	+

 For voltage supply of 208-240 V AC always use coil with electronic coil controller type ECC.

**Ordering**
*Coil with electronic coil controller*

Coil with electronic coil controller type EEC is delivered as multipack.

AC coil	Code no.	18 bar		35 bar <sup>3)</sup>	
208 - 240VAC, 50/60 Hz, 4W	<b>018F6783</b>	+	+	+	+

<sup>1)</sup> Recommended for commercial refrigeration plant

<sup>2)</sup> 20 W coils can not be connected to AKC 24P2 and AKC 24W2

<sup>3)</sup> If operated consistently at or near MOPD, the service interval will decrease.

## Capacity

**R744**

Valve type	Capacity in kW at pressure drop across valve $\Delta p$ bar 1)								
	2	4	6	8	10	12	14	16	18
AKVH 10 - 0	0.33	0.44	0.53	0.59	0.65	0.70	0.73	0.76	0.78
AKVH 10 - 1	0.9	1.2	1.5	1.6	1.8	1.9	2.0	2.1	2.1
AKVH 10 - 2	1.4	2.0	2.3	2.6	2.8	3.1	3.2	3.3	3.4
AKVH 10 - 3	2.2	3.1	3.7	4.1	4.4	4.8	5.0	5.2	5.4
AKVH 10 - 4	3.6	4.9	5.8	6.5	7.1	7.7	8.0	8.3	8.5
AKVH 10 - 5	5.6	7.7	9.2	10.2	11.1	12.0	12.6	13.0	13.5
AKVH 10 - 6	9.0	12.3	14.6	16.3	17.6	19.1	20.0	20.8	21.5

Valve type	Capacity in kW at pressure drop across valve $\Delta p$ bar								
	20	22	24	26	28	30	32	34	35
AKVH 10 - 0	0.80	0.81	0.82	0.84	0.85	0.85	0.86	0.87	0.87
AKVH 10 - 1	2.2	2.2	2.3	2.3	2.3	2.4	2.4	2.4	2.4
AKVH 10 - 2	3.5	3.6	3.7	3.7	3.8	3.8	3.8	3.8	3.8
AKVH 10 - 3	5.5	5.6	5.7	5.8	5.9	5.9	6.0	6.0	6.0
AKVH 10 - 4	8.8	8.9	9.1	9.3	9.4	9.5	9.5	9.6	9.6
AKVH 10 - 5	13.8	14.1	14.4	14.6	14.8	14.9	15.0	15.0	15.0
AKVH 10 - 6	22.0	22.4	22.9	23.3	23.5	23.7	23.9	23.9	24.0

1) Rated capacities are based on  
 Subcooling  $t_{sub} = 4K$   
 Evaporating temperature  $t_e = -25^\circ C$   
 Superheating  $t_{sup} = 5K$

**Valve sizing using calculation software**

It is strongly recommended to use Cool Selector to find the correct valve for our application. The software can be downloaded from the Danfoss website. When using the calculation software it is recommended to choose a valve that is between 50 and 75% loaded at the nominal capacity. In addition, the liquid velocity in the line leading to the valve should not exceed 1m/s (3ft/s).

**Valve sizing**

To obtain an expansion valve that will function correctly under different load conditions it is necessary to consider the following points when sizing the valve.  
These points must be dealt with in the following sequence:

- 1) Evaporator capacity
- 2) Pressure drop across the valve
- 3) Correction for subcooling
- 4) Correction for evaporating temperature
- 5) Determination of valve size
- 6) Correctly dimensioned liquid line

1) *Evaporator capacity*

The evaporator capacity is found in the specifications from the evaporator supplier.

2) *Pressure drop across the valve*

The pressure drop across the valve directly determines the capacity and must therefore be considered.

The pressure drop across the valve is normally calculated as the receiver pressure less the evaporating pressure and sundry other pressure drops in the liquid line, distributor, evaporator, etc. It is indicated in the following formula:  

$$\Delta p_{\text{valve}} = p_c - (p_e + \Delta p_1 + \Delta p_3 + \Delta p_4)$$

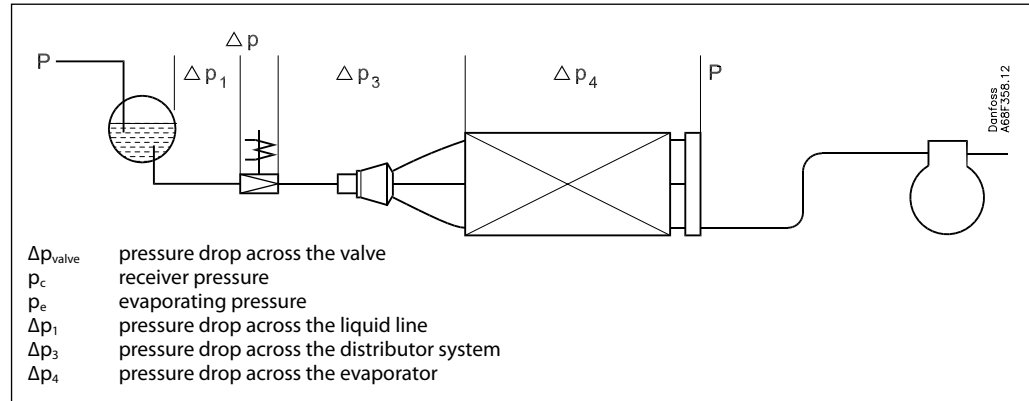

Note! The pressure drop across the liquid line and the distributor system must be calculated on the basis of the valve's max. capacity, as the valve operates with pulse-width modulation.

This will give you the following equation:  

$$\begin{aligned} \Delta p_{\text{valve}} &= p_c - (p_e + \Delta p_1 + \Delta p_3 + \Delta p_4) \\ &= 40 - (29.4 + 0.2 + 0.8 + 0.1) \\ &= 9.5 \text{ bar} \end{aligned}$$

*Example of calculation of pressure drop across a valve:*

Refrigerant: R744  
 $p_c$  = Receiver pressure: 40 barg (at 6°C)  
 Evaporating temperature: -5°C ( $p_e = 29.4$  barg)  
 $\Delta p_1 = 0.2$  bar  
 $\Delta p_3 = 0.8$  bar  
 $\Delta p_4 = 0.1$  bar

The found value for "pressure drop across the valve" is used later in the section "Determination of valve size".

**Valve sizing** (continued)

3) *Correction for subcooling*

The evaporator capacity used must be corrected, if the subcooling deviates from 4 K. Use the actual correction factor indicated in the table.

Multiply the evaporator capacity by the correction factor to obtain the corrected capacity.

*Correction factors for subcooling  $\Delta t_{sub}$*

Correction factor	4 K	10 K	15 K	20 K	25 K	30 K	35 K	40 K	45 K	50 K
R744	1.00	0.91	0.86	0.81	0.77	0.73	0.69	0.66	0.63	0.60

Corrected capacity = evaporator capacity x correction factor.

The corrected capacity is used in the section "Determination of valve size".

Correction factor according to the table = 0.91  
Corrected capacity = 5 × 0.91 = 4.55 kW.

*Example of correction:*  
Refrigerant: R744  
Evaporator capacity  $Q_e$ : 5 kW  
Subcooling: 10 K

*Note: Too little subcooling may cause flash gas.*

4) *Correction for transient conditions and evaporating temperature ( $t_e$ )*

To obtain a correctly dimensioned valve it is important that the application is considered. Depending on the application, the valve should have an overcapacity enabling it to cope with the extra amount of refrigeration needed during certain periods, e.g. during the defrost recovery process.

The valve's opening degree should therefore be between 50 and 75% when regulating. In this way it is ensured that the valve has a sufficiently wide regulation range, so that it can manage changed loads at or near the normal working point. The change in capacity as an effect of the deviation in refrigerant density is included in this correction factor.

*Correction factor for transient conditions and evaporating temperature ( $t_e$ )*

Evaporating temperature $t_e$ °C	10 to -50
AKVH 10	1.6

5) *Determination of valve size*

When the valve size meeting the required capacity is selected it is important to note that the capacity indications are the valve's rated capacity, i.e. when the valve is 100% open. In this section we tell you how the valve's size is determined.

There are three factors that have an influence on the choice of the valve:

- the pressure drop across the valve
- the corrected evaporator (correction for subcooling)
- the corrected capacity for evaporating temperature

The three factors have been described earlier in this section on dimensioning. When these three factors have been established, the selection of the valve can be made:

- First you multiply the "corrected capacity" by a value stated in the table.
- Use the new value in the capacity table in combination with the pressure drop value.
- Now select the valve size.

*Example of selection of valve*

Use as starting point the two earlier mentioned examples, where the following two values have been obtained:

$\Delta p_{valve} = 9.5$  bar

$Q_{e \text{ corrected}} = 4.55$  kW

The valve should be used in a coldroom.

1.6 is the "correction factor for the evaporating temperature".

The dimensioned capacity will then be:  
 $1.6 \times 4.55 \text{ kW} = 7.28 \text{ kW}$ .

Now select a valve size from one of the capacity tables.

With the given values  $\Delta p_{valve} = 9.5$  bar and a capacity of 7.28 kW, select the valve size for AKVH 10-5.

This valve has a capacity of approx. 10.2 kW

Valve sizing (continued)

6) Correctly dimensioned liquid line

To obtain a correct supply of liquid to the AKVH valve, the liquid line to the individual AKVH valve must be correctly dimensioned.

The liquid flow rate should not exceed 1 m/sec.

This must be observed on account of the pressure drop in the liquid line (lack of subcooling) and pulsations in the liquid line.

Dimensioning of the liquid line must be based on the capacity of the valve at the pressure drop with which it is operating (cf. capacity table), and not on the evaporator's capacity.

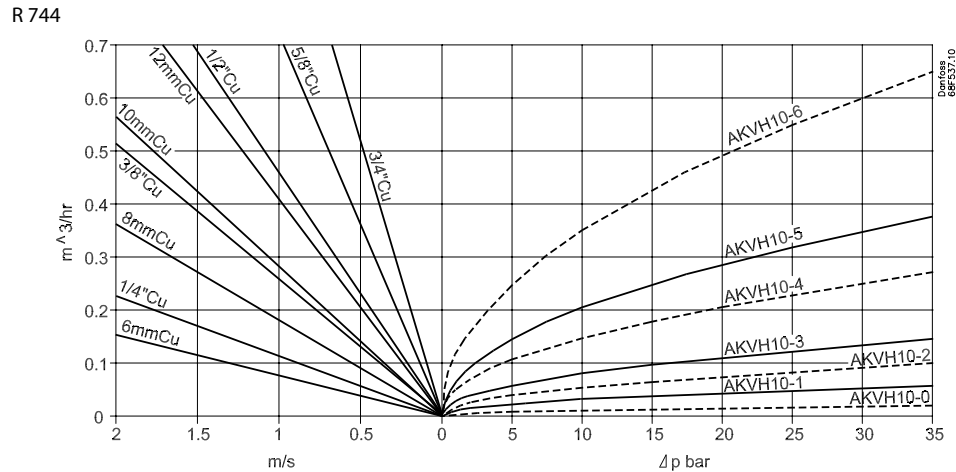

Design

1. Inlet
2. Outlet
3. Orifice
4. Filter
5. Valve seat
6. Armature
7. Copper gasket
8. Coil
9. DIN plug
12. O-ring

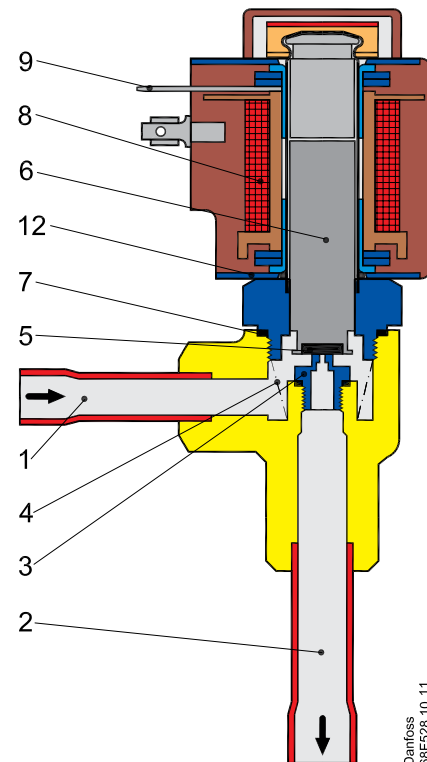

Function  
AKVH valves

The valve capacity is regulated by means of pulse-width modulation. Within a period of six seconds a voltage signal from the controller will be transmitted to and removed from the valve coil. This makes the valve open and close for the flow of refrigerant.

The relation between this opening and closing time indicates the actual capacity. If there is an intense need for refrigeration, the valve will remain open

for almost all six seconds of the period. If the required amount of refrigeration is modest, the valve will only stay open during a fraction of the period. The amount of refrigeration needed is determined by the controller.

When no refrigeration is required, the valve will remain closed and thus function as a solenoid valve.

**Function**  
**Coil with electronic coil controller**

The electronic control ramps up the current over a preset time. The electronic control is integrated with the coil to give the coil a short over-boost and thereby increase the MOPD of the AKVH valve.

The electronic control adjusts the running current between 0% and 100% at a preset level giving lower energy consumption and less wear.



**Dimensions and weights**  
**AKVH valve**

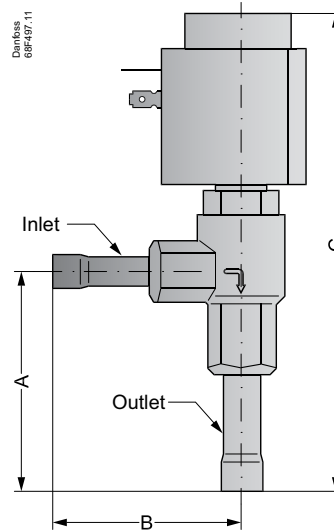

AKVH 10 solder

Valve type	Connection type	n	A	S	C	Inlet		Outlet		Weight without coil kg
			mm	mm	mm	inch	mm	inch	mm	
AKVH 10-n	Solder	0, 1, 2, 3, 4, 5, 6	75	67	154	3/8	10	1/2	12	0.38

**Dimensions**  
**Coil with electronic coil controller**

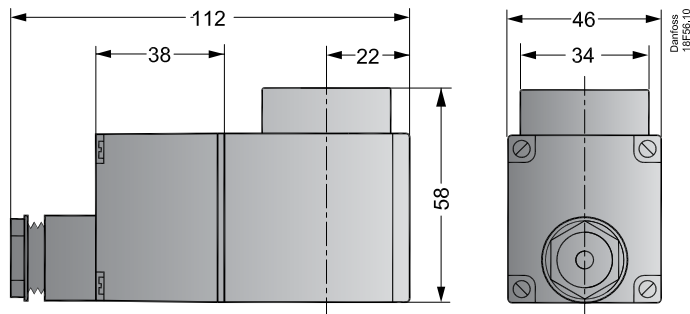

Danfoss can accept no responsibility for possible errors in catalogues, brochures and other printed material. Danfoss reserves the right to alter its products without notice. This also applies to products already on order provided that such alterations can be made without consequential changes being necessary in specifications already agreed. All trademarks in this material are property of the respective companies. Danfoss and the Danfoss logotype are trademarks of Danfoss A/S. All rights reserved.