



Installation guide

Thermostatic expansion valve Type TR6

067R9508

067R9508

Refrigerants:
R22/R407C and R410A

Max. working pressure:
PS / MWP = 42 bar / 610 psig

Max. test pressure:
47 bar / 680 psig

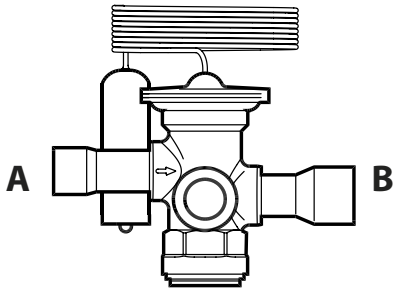

Fixed setting

Flow direction:

→
Normal: A → B

←
Reverse: B → A

$Q_{nom. A \rightarrow B} [kW / TR] = 100\%$

$Q_{nom. B \rightarrow A} [kW / TR] = 80\%$

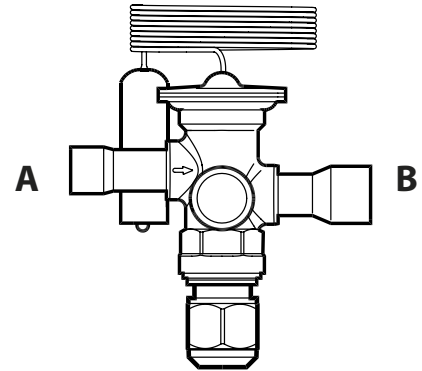

Adjustable setting

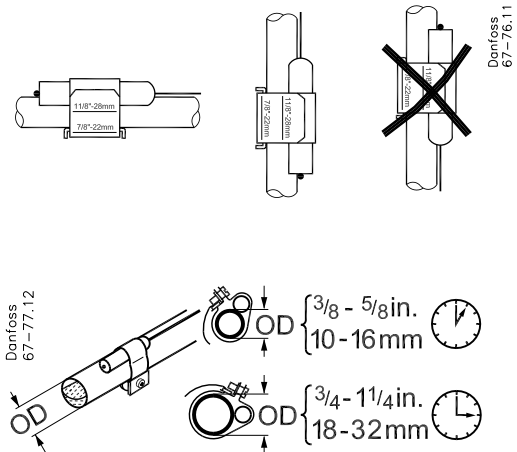
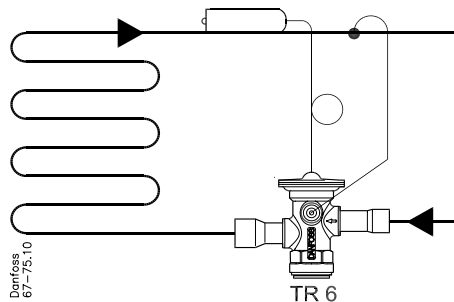
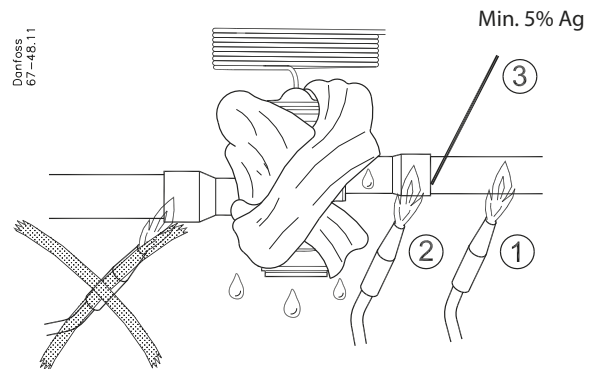
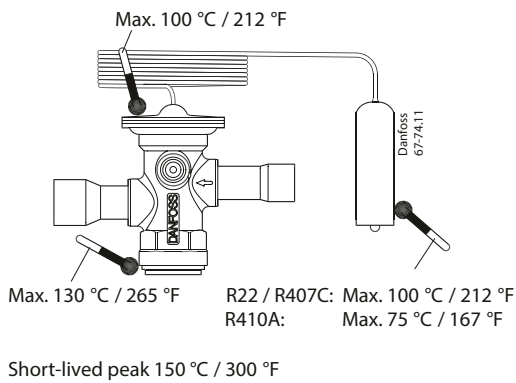

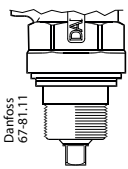
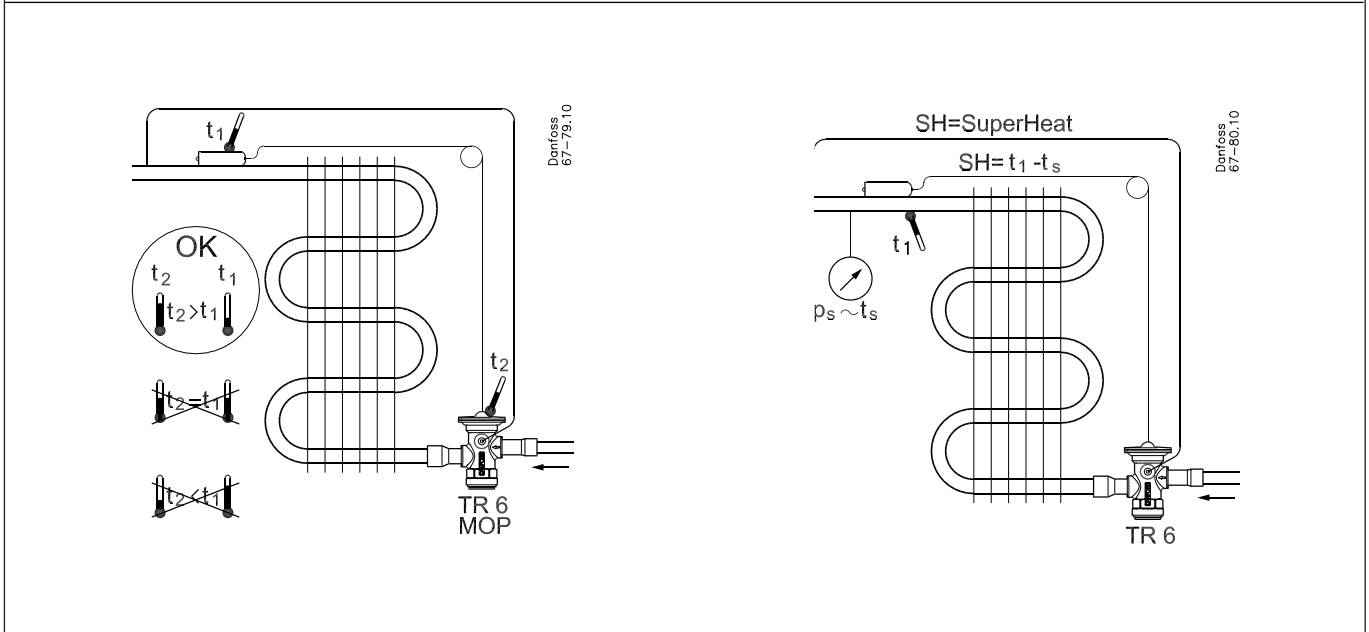
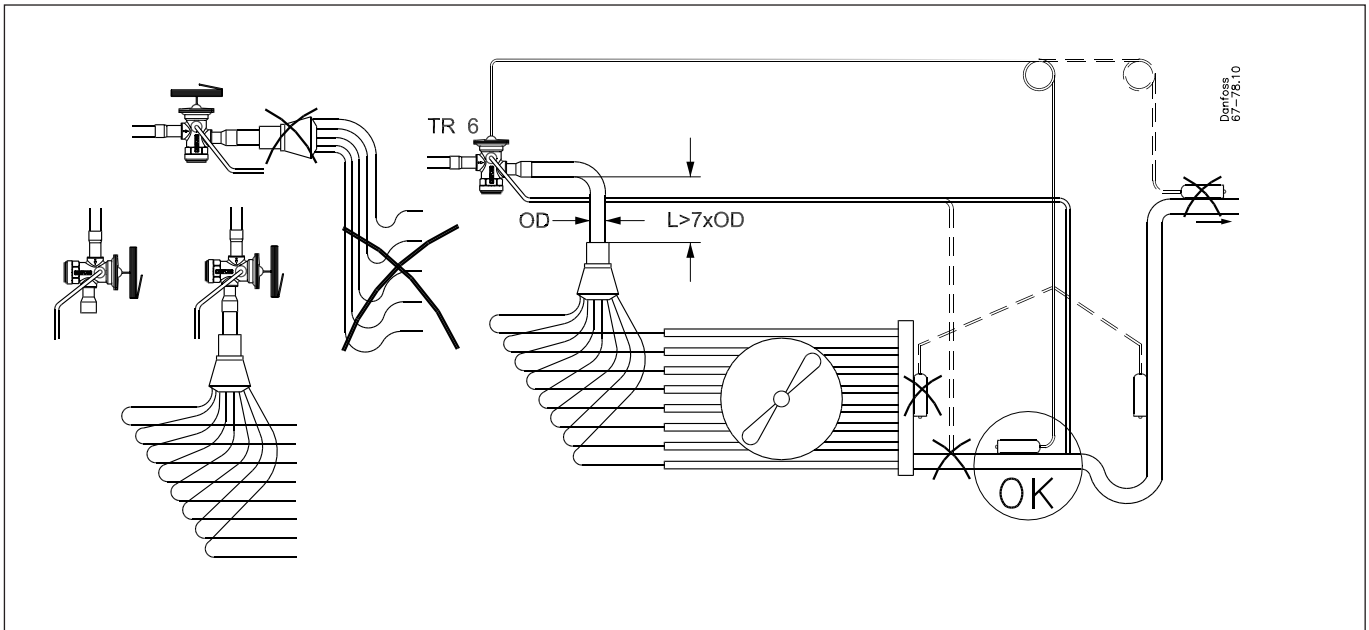

Danfoss
67-81.11



Hexagon = 19 mm / 3/4 in.

Torque = 10 Nm / 7 ft-lb

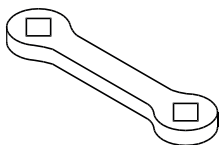

Δ SH / 1 turn / 360° \approx

R22 / R407C: 1.0 °C / 1.8 °F

R410A: 0.8 °C / 1.1 °F



Factory setting

R22/R407C

SS = 4 K or according to customer specification

R410A

SS = 3 K or according to customer specification

Refrigerant	Number of turns from SS to tight spring 	Number of turns from SS to loose spring 
R22 / R407C	+7.25	-4.25
R410A	+9.5	-2