

Installation guide

# Check and Stop valve

## Type OFC

UK  
CA

020R5421



020R5421



**Refrigerant:**

UL listed for R134a, R513A and R515B. CE approved for fluid group 2, including R1234ze(E)  
For other refrigerants, visit <http://store.danfoss.com/> and search for individual code, where refrigerants are listed as part of product details.  
Oil: OFC valve is designed for an oil-free environment

**Media Temperature:**

Min. 0 °C / 32 °F  
Max. 90 °C / 194 °F, short term up to 100°C / 212°F

**Max. Working Pressure:**

PS/MWP = 23 bar / 334 psig

**Installation:**

Install valve directly on Danfoss Turboacor compressor, picture shown with vertical down installation.  
Protect the valve from impact in the installation.

All fasteners and bolts require stainless steel. Bolts with minimum class A2-70.



**NOTE:** Protection of entire valve including steel flange is recommended after installation for outdoor use.

Reference specific compressor requirements

Ball valve clocking may be changed by removing bolts and rotating ball valve housing without retracting the ball valve assembly away from the elbow (for the type of check and stop valve).



**NOTE:** refer to check valve orientation options below

Torque: 38 Nm ± 4 Nm

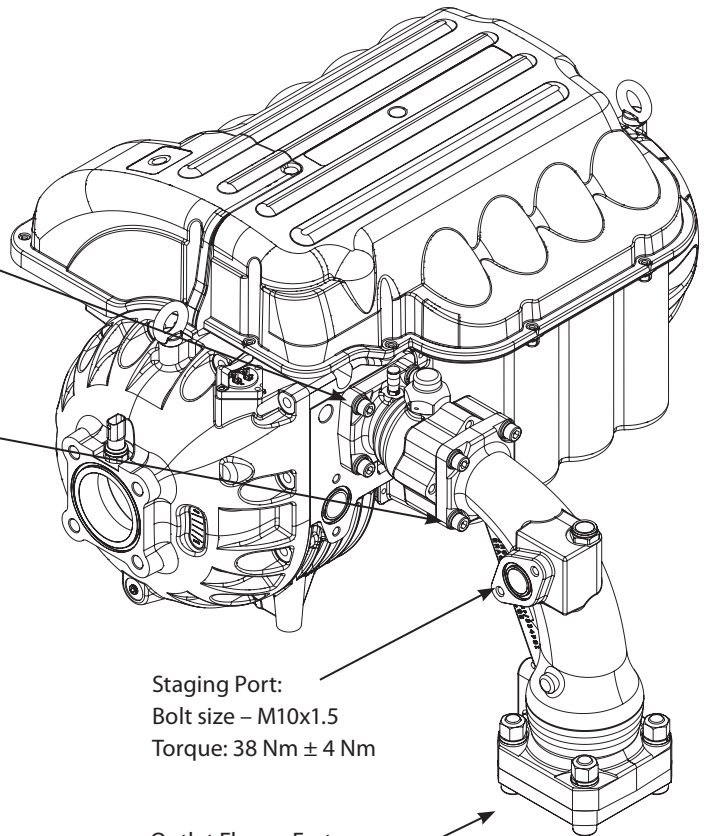

Staging Port:  
Bolt size – M10x1.5  
Torque: 38 Nm ± 4 Nm

Outlet Flange Fasteners:  
Torque - 110 Nm

**Outlet Flange Brazing:**  
Place outer flange on evenly cut copper pipe



**NOTE:** ensure flange is not mounted on main housing during brazing

Min 5% Ag

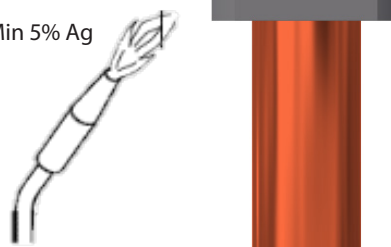

Info for UK customers only: Danfoss Ltd., 22 Wycombe End, HP9 1NB, GB

**Orientation:**

**NOTE:** Check valve spring must be changed when using any orientation other than vertical downing  
**For check and stop valve:**

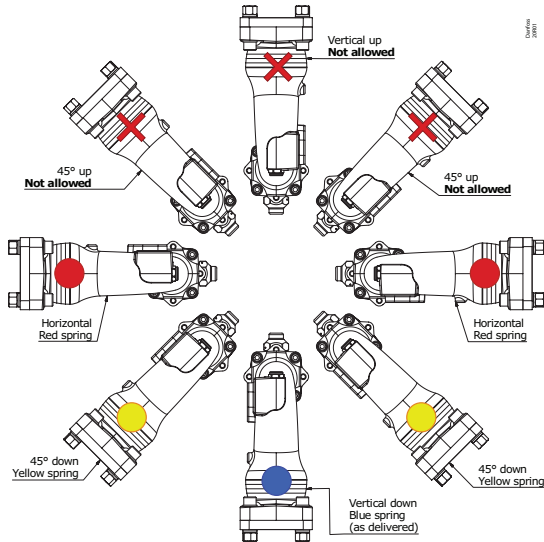

**For check valve without ball valve:**

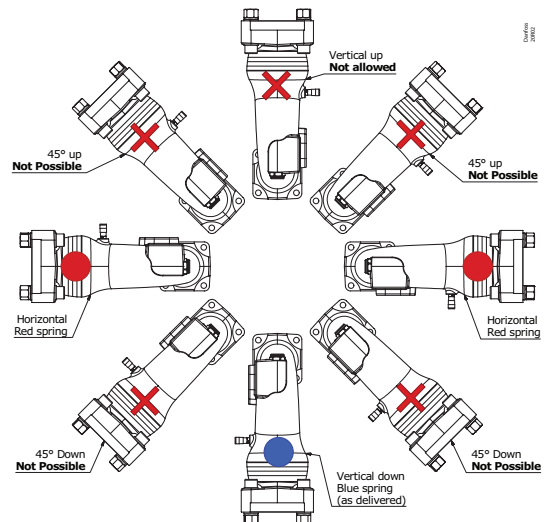

**For check and stop valve:**

Always replace lock ring and cap after opening/ closing the ball valve

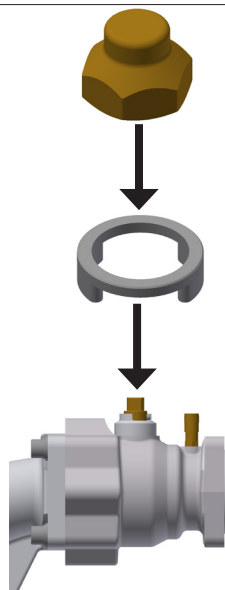

**When changing check valve spring:**

1. Remove check valve insert from main housing
2. Remove check valve head
3. Remove spring and replace with correct color based on intended orientation
4. Replace check valve head and insert
5. Install outlet flange, O-ring and fasteners

