

Data sheet

VZ valve - 2/3/4-way

Description



VZ valves provide a high quality, cost effective solution for the control of hot and/or chilled water for fan coil units, small reheaters, and recoolers in temperature control systems.

The valves are used in combination with AMV(E) 130/140, AMV(E) 130H/140H and AMV(E) 13 SU actuators.

Main data:

- DN 15, 20
- k_{vs} 0.25 - 4.0 m³/h
- PN 16
- Logarithmic flow characteristic
- Temperature:
 - Circ. water / glycolic water up to 50%: 2 ... 120 °C
- Reduced k_{vs} on B port (VZ3 & VZ4 only)
- Linear bypass on 3 and 4 port valves
- Valves are supplied with screwed plastic cover for manual operation
- Connections: flat end or conex

Ordering

VZ 2 Valve

Picture	DN (mm)	k_{vs} (m ³ /h)	Max. Δp (bar)	Code No.
				Flat End
	15	0.25	3.5 (1)*	065Z5310
		0.4		065Z5311
		0.63		065Z5312
		1.0		065Z5313
		1.6		065Z5314
	20	2.5	2.5 (1)*	065Z5315
		2.5		065Z5320
		4.0		065Z5321

(1)* recommended Δp

VZ 3 Valve

Picture	DN (mm)	k_{vs} (A-AB)	k_{vs} (B-AB)	Max. Δp (bar)	Code No.
		m ³ /h			Flat End
	15	0.25	0.25	3.5 (1)*	065Z5410
		0.4	0.25		065Z5411
		0.63	0.4		065Z5412
		1.0	0.63		065Z5413
		1.6	1.0		065Z5414
	20	2.5	1.6	2.5 (1)*	065Z5415
		2.5	1.6		065Z5420
		4.0	2.5		065Z5421

(1)* recommended Δp

Ordering (continuous)

VZ 4 Valve

Picture	DN (mm)	k_{vs} (A-AB)	k_{vs} (B - AB)	Max. Δp (bar)	Code No.
		m ³ /h			Flat End
	15	0.25	0.25	3.5 (1)*	065Z5510
		0.4	0.25		065Z5511
		0.63	0.4		065Z5512
		1.0	0.63		065Z5513
		1.6	1.0		065Z5514
		2.5	1.6		065Z5515
	20	2.5	1.6	2.5 (1)*	065Z5520
		4.0	2.5		065Z5521

(1)* recommended Δp

NOTE:

k_{vs} - is the flow in m³/h of water at a temperature between 5 °C and 40 °C which passes through a valve open at the nominal stroke with 100 kPa (1 bar) pressure drop.

Max. Δp is the physical limit of differential pressure the valve will close against. The recommended Δp - values in parentheses (1) is based on the generation of noise, plug erosion etc. It should be checked against the Δp figure calculated from the chart on page 4 or the equation below, with the valve fully opened at the designed flow rate.

$$\Delta p_{\text{valve}} = S \left(\frac{Q}{k_{vs}} \right)^2$$

- S = specific gravity
- Q = flow rate in m³/h
- Δp_{valve} = pressure drop across valve in bar (fully open).

Conversion factors
 1 bar = 100 kPa = 14.5 psi
 1 l/s = 1 kg/s = 3.6 m³/h

Accessories

Connection	Pipe size	DN	Description	Code No.
Tailpieces with external thread	R 3/8"	15	Consist of 2 union nuts, 2 tailpieces and 2 gaskets (Ms 58)	065Z7015
	R 1/2"	20		003H6902

Connection	Pipe size	DN	Description	Code No.
Tailpieces for soldering	12 mm	15	Consist of 2 union nuts, 2 solder bushes and 2 gaskets (Ms 58)	065Z7016
	15 mm	20		065Z7017

Technical data

Control characteristic	Logarithmic	
Control range	min. 50:1	
Leakage loss, closed valve	A - AB ≤ 0.05 % of kVS	
	B - AB ≤ 1 % of kVS	
Medium	Circulation water / Glycolic water up to 50 %	
Medium temperature	°C	2 ... 120
Max. operating pressure	bar	1
Stroke	mm	5.5
Connection	External thread (flat connection (MS 58) or conex)	
Materials		
Body, seat and cone	Dezincing free brass CuZn36Pb2As	
Stem	Stainless steel	
Stuffing box	EPDM	

Pressure temperature diagram

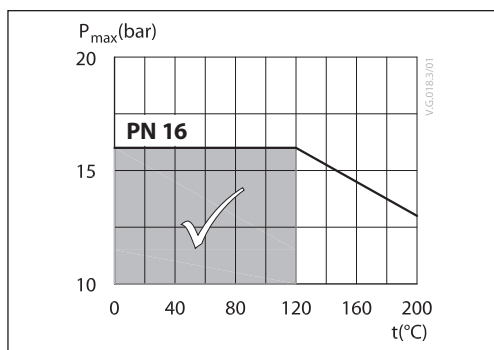

Disposal

The valve must be dismantled and the elements sorted into various material groups before disposal.

Manual operation

Valves are supplied with screwed plastic cover for manual operation.

Note: The flow is reduced on 75 % in case of using plastic cover.

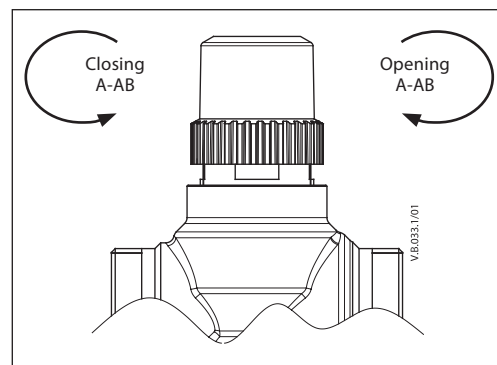

Installation

Hydraulic connections

Mount according to flow direction as indicated on the valve body. AB is always the outlet port; inlets are A (two port) or A and B (three or four port).

Valve mounting

Before mounting the valve be sure that the pipes are clean and free from swarf. It is essential that the pipes are lined up squarely with the valve at each connection and are free from vibrations.

The valve should be adequately supported to prevent stress being applied to the connections during operation. A maximum tightening torque of 25 to 30 Nm should be applied to the connections.

Install the valve so that the actuator will be mounted in a vertical or horizontal position but not upside down.

Leave sufficient clearance to allow the dismantling of the actuator from the valve body for maintenance purposes.

The valve must not be installed in an explosive atmosphere or at an ambient temperature higher than 50 °C or lower than 2 °C. It must not be subjected to steam jets, water jets or dripping liquid.

Note that the actuator may be rotated up to 360° with respect to the valve body, by loosening the retaining fixture. After this operation retighten.

Ensure that the direction of flow is correct as shown in typical application examples (fig.1 and 2). The three way valve must be installed as a mixing valve. If possible the valves should be positioned in the return side.

The valve is supplied complete with installation instructions. The water quality should meet VDI 2035 requirements.

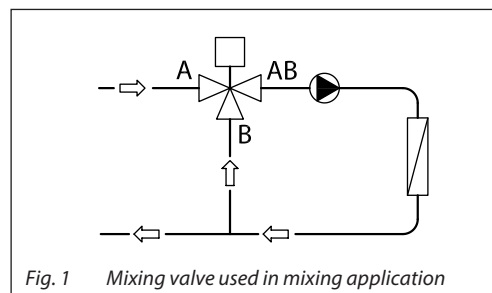
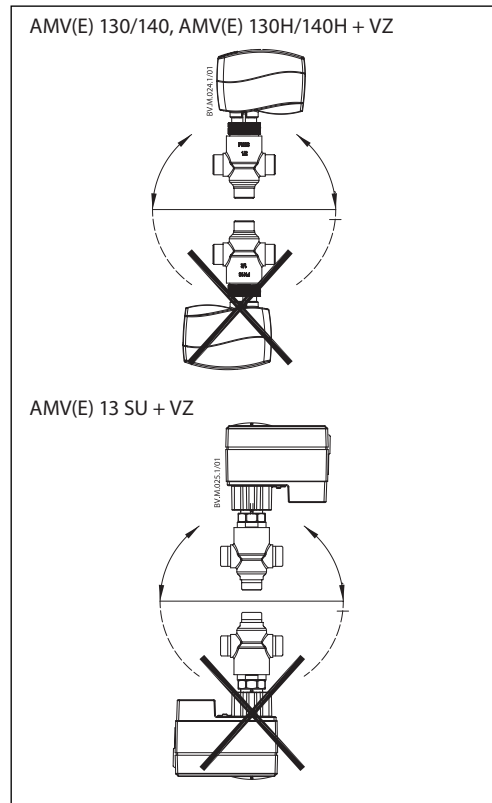

Fig. 1 Mixing valve used in mixing application

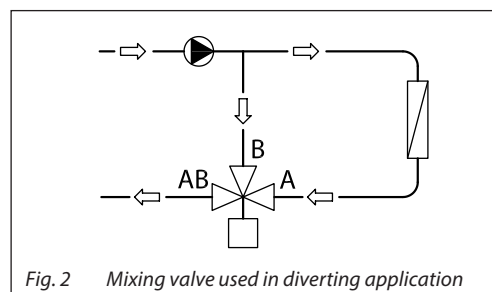
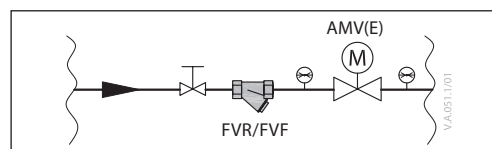

Fig. 2 Mixing valve used in diverting application

Note:
Install a strainer upstream of the valve (e.g. Danfoss FVR/FVF)



Sizing

Example

Flow rate: 0.3 m³/h
 System pressure drop: 20 kPa

Locate the horizontal line representing a flow rate of 0.3 m³/h (line A). The valve authority is given by the equation:

$$\text{Valve authority, } N = \frac{\Delta P_1}{\Delta P_1 + \Delta P_2}$$

Where:

ΔP_1 = pressure drop across the fully open valve,
 ΔP_2 = pressure drop across the rest of the circuit with a fully open valve

The ideal valve would give a pressure drop equal to the system pressure drop (i.e. an authority of 0.5):

If $P_1 = P_2$
 $N = P_1 / 2P_1 = 0.5$

In this example an authority of 0.5 would be given by a valve having a pressure drop of 20 kPa at that flow rate (point B).

The intersection of line A with a vertical line drawn from B lies between two diagonal lines; this means that no ideally-sized valve is available. The intersection of line A with the diagonal lines gives the pressure drops stated by real, rather than ideal, valves. In this case, a valve with k_{vs} 0.6 would give a pressure drop of 25 kPa (point C):

hence valve authority = $\frac{25}{25 + 20} = 0,56$

The second-largest valve, with k_{vs} 1, would give a pressure drop of 9 kPa (point D):

hence valve authority = $\frac{9}{9 + 20} = 0,31$

Generally, for a 3 port application, the smaller valve would be selected (resulting in a valve authority higher than 0.5, and therefore improved controllability). However, this will increase the total pressure and should be checked by the system designer for compatibility with available pump head, etc. The ideal authority is 0.5 with a preferred range of between 0.4 and 0.7.

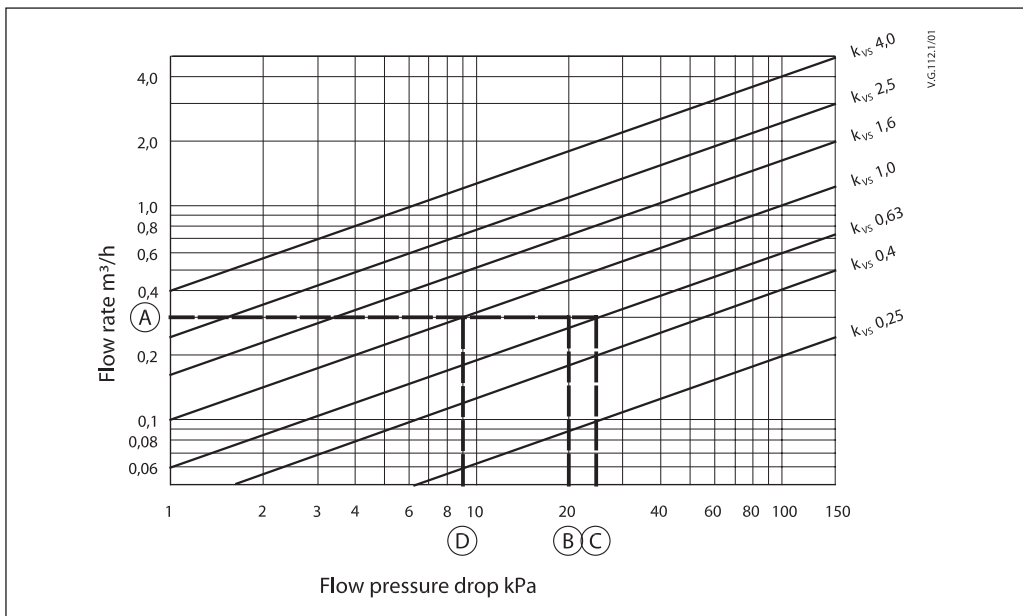

Design

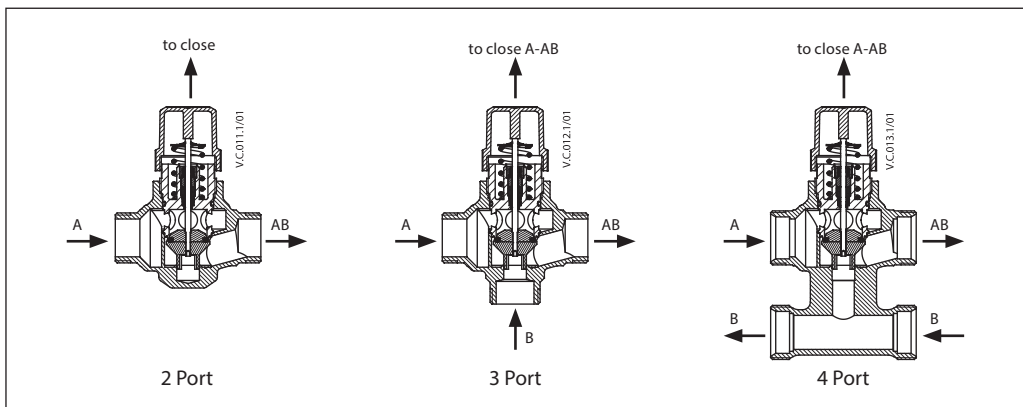

Dimensions

AMV(E) 130/140 + VZ 2 AMV(E) 130/140 + VZ 3 AMV(E) 130/140 + VZ 4

AMV(E) 130H/140H + VZ AMV(E) 13 SU + VZ

Valve type	d	L	H	H ₁	H ₂	h	h ₁	c	Valve weight (kg)
		mm							
VZ 2 / DN 15	G 1/2"	65	119	125	155	26.5	52.5	-	0.38
VZ 2 / DN 20	G 3/4"	77							0.49
VZ 3 / DN 15	G 1/2"	65				0.39			
VZ 3 / DN 20	G 3/4"	77				0.50			
VZ 4 / DN 15	G 1/2"	65				40			0.51
VZ 4 / DN 20	G 3/4"	77				50			0.62

Tailpieces for soldering

G	Ød	L	Weight (kg)
	mm		
1/2"	12	15	0.11
3/4"	15	20	0.17

Tailpieces with external thread

G	R	L (mm)	Weight (kg)
	(")		
1/2"	3/8	23	0.11
3/4"	1/2	26	0.17



Danfoss A/S

Heating Segment • heating.danfoss.com • +45 7488 2222 • E-Mail: heating@danfoss.com

Danfoss can accept no responsibility for possible errors in catalogues, brochures and other printed material. Danfoss reserves the right to alter its products without notice. This also applies to products already on order provided that such alterations can be made without subsequential changes being necessary in specifications already agreed. All trademarks in this material are property of the respective companies. Danfoss and all Danfoss logotypes are trademarks of Danfoss A/S. All rights reserved.
