



Data sheet

CCR3+ Controller

Return temperature controller & temperature registration

Description



The CCR3+ Controller is an electronic controller for return temperature control in risers in one-pipe heating system based on supply temperature signal. With CCR3+ controller one-pipe heating system becomes efficient variable flow system with riser's flow control based on heat demand.

CCR3+ is dedicated to be used with AB-QM automatic balancing & control valve equipped with thermo actuators type TWA-Z (NO) and remote temperature sensors type ESMC.

CCR3+ together with AB-QM and TWA-Z is complete one-pipe electronic solution: AB-QTE

Main data:

- Designed for AB-QM DN 10-32 mm
- Maximum number of controlled risers: 20 (extension +16 via Slave Unit)
- No distance limitation between risers (control valves) and controller
- Pulse Wide Modulation (PWM) algorithm
- Return temperature (curve) adjustable in 9 points
- Individual riser setting possible
- Possible connection to BMS system
- Build in web server for access via mobile devices or PC (readings, settings, datalogs, etc)
- LED status indicators
- Flow control in risers based on heat demand
- Build in Web-Server App, Wi-Fi connection and LAN port

Benefits

- Improved room temperature control
- Eliminated overheating of the building
- Reduced heating cost with payback time less than 4 years
- Remote control and access of all temperature setting (no need to have direct access to risers!)

Ordering

Inclusive in the box: CCR3+ Controller, 1 pcs ESMC sensor

Type	Designation	Supply voltage	Actuator type/nos.	Code No.
CCR3+ Controller	Return Temperature Controller & Temperature Registration	24 Vdc	NO/20	003Z0396

Accessory

Type	Designation	Voltage	Comments	Code No.
TWA-Z (NO)	Thermal actuators	24 V	1.2 m. cable	082F1220
Set: TWA-Z (NO) with ESMC (PT 1000)	Thermal actuators with surface sensor	24 V	-	003Z0388
ESMC (PT 1000)	Surface sensor	-	2 meters cable	087N0011
CCR+ Slave Unit	System expansion (add 16 risers)	24 Vdc	-	003Z3852

Applications

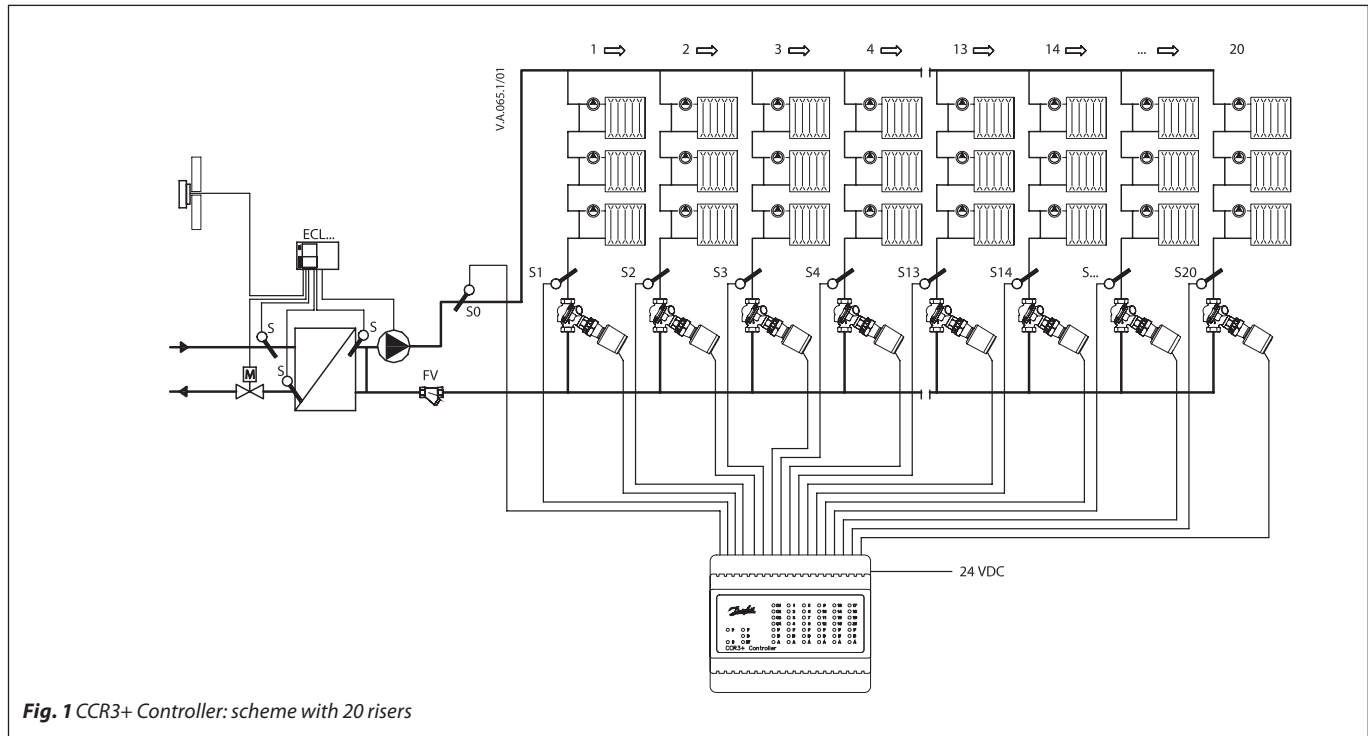

Fig. 1 CCR3+ Controller: scheme with 20 risers

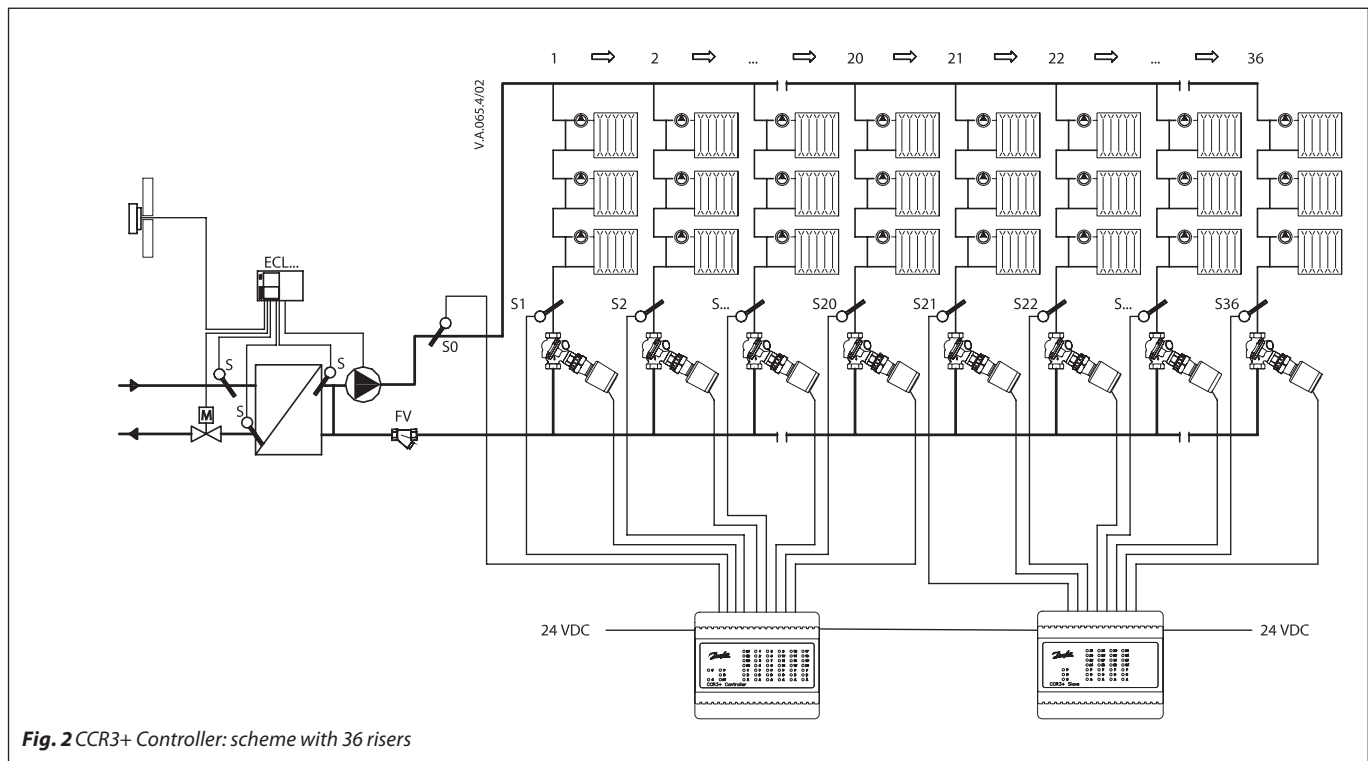

Fig. 2 CCR3+ Controller: scheme with 36 risers

Applications (Continuous)

AB-QTE solution converts one-pipe heating system - usually permanent flow system - into efficient variable flow system.

This innovative solution dynamically controls the flow in risers according to the load in risers by return temperature control. Wide range of return temperature setting (9 setting points) ensures high efficiency of the system in whole range of supply temperature from 35-90 °C.

In one-pipe systems flow in the risers is always present even when all TRV's are closed; water flow through the by-pass which result in high operating costs (heat losses, pumping costs, overheating etc). TRV on the radiator controls room temperature by controlling flow through the radiator, while flow ratio between radiator and by-pass is varying; however total flow in risers remains permanent. At partial loads (some TRV's are closed) return water temperature in risers increases, which results in overheating of rooms due to very hot risers.

After the building is renovated heating system becomes oversized since the heat losses of the building decrease. As a result overheating issue increases even more.

CCR3+ controller is part of AB-QTE solution for one-pipe heating systems. It converts one-pipe heating system (usually constant flow system) into efficient variable flow system. This innovative solution dynamically controls the flow in the riser according to the load in risers by return temperature control. Wide range of return temperature setting (9 setting points) ensures high efficiency of the system in whole range of supply temperature from 35-90 °C.

In traditional one-pipe systems flow in the risers is present even when all TRV's are closed. Water flows through the by-pass at all times. TRV on the radiator controls room temperature by controlling flow through the radiator, while flow ratio between radiator and by-pass is varying. Total flow in risers remains permanent though. At partial loads (some TRV's are closed) return water temperature in risers increases. Result is high operating costs: heat losses, pumping costs, overheating, etc. In case building is renovated overheating issue increases even more as heating system becomes oversized.

AB-QTE concept solution:

- AB-QM mounted in the risers provides right water balance in the risers at all system condition. Every riser get designed flow and each riser is independent from the rest of installation.
- CCR3+ with temperature sensors and actuators mounted on AB-QM controls flow in risers through the return temperature control. When return temperature increases CCR3+ automatically detects this change and reduces flow in risers according to set points (lower load in risers – lower flow needed). This results in improved room temperature control and greatly reduced overheating of the building.

Compared to self- acting solution (QT thermostatic elements), AB-QTE solution covers very wide temperature setting range, as presented in Fig. 3. All points of return temperature setting correspond to supply temperature what allows automatic adaptation to weather condition according the rules: lower outside temperature , higher supply temperature – except higher return temperature, but all time optimized at any supply parameter.

- Thus one-pipe system becomes energy efficient variable flow system.
- AB-QTE solution is perfect from service, monitoring and maintenance point of view. The CCR2+ incorporates LED status indicator, build in Web-Server App, Wi-Fi connection and LAN port, which allow the user to manually set, log and monitor measured parameters from the system on smart device or PC.

Danfoss AB-QTE solution for one-pipe renovation system is a top end solution where the first double curve system control is proposed. First: on primary side , usually in sub-station where weather compensatory control supply temperature according out-door temperature (based on weather compensator curve). Second one: on secondary side where return temperature curve is adjusted based on supply water temperature. Lower outside temperature requires higher supply temperature which yields to also higher return temperature. Key point: at all times optimized. Thus one-pipe system becomes energy efficient variable flow system.

The return temperature can be adjusted in eight points, each correspondent to one flow temperature.

The setting can be automatically applied for all risers or using from menu additional setting function return temperature can be modified individually to each riser by:

Shift factor – allow to move up and down the curve in each point, setting range ± 10 °C.

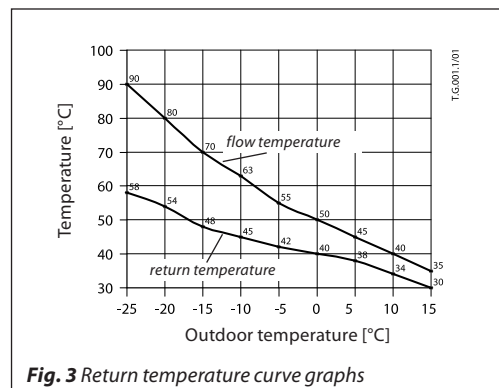

Fig. 3 Return temperature curve graphs

Technical data

Temperature sensor (S0, S1-S20 / S21-36)	Pt1000, S0 – type ESMC/ESM11, S1-S20 / S21-36 – type ESMC
Temperature range (registration)	-20 °C ... +120 °C
Measuring accuracy	+/- 0.5 K
Inputs: B1, B2 & B3	Free contact (5 V 1 mA)
Number of control valves (risers)	20 basic, additional 16 with system extension via CCR+ Slave Unit
Output signal to actuators	24 VDC max. 1 A
Alarm signal output	24 VDC max. 1 A
Relay output	0-24 VDC max. 1A
Type of memory	Build-In
Capacity of memory	8 GB
Timer: Real time clock	Built-in battery – powered for 10 years
Communication interfaces	- Wi-Fi (communication port only) - TPC/IP port (LAN cable connection) - Modbus RS485 RTU - IP Modbus (LAN cable connection)
Default IP settings:	- Default LAN IP address (static): 192.168.1.100 - Default WiFi access IP address (static): 192.168.1.10 - IP address mask: 255.255.255.0 - Gateway address: 192.168.1.1 - DNS address: 192.168.1.1 - CCR name: ccrplus - Default password: admin1234
Ambient temperature	0 ... +50 °C (for CCR3+ only. The ambient temperature for actuators TWA-Z (NO) should not be above 30 °C)
Transport temperature	-10 ... +60 °C
IP rating	IP 20
Power supply	24 VDC
Power consumption (Controller only) ¹⁾	10 VA
Power consumption (Slave Unit only) ¹⁾	VA
Weight	0.3 kg
Installation	DIN rail 35 mm

¹⁾ To select proper power transformer please follow formula: 24 V 10VA (controller) + 7 VA*/per each actuator

Settings

Flow on AB-QM and temperature setting on CCR3+ Controller need to be set to achieve best performance and efficiency of one-pipe heating system.

Recommended is a following 3 steps setting procedure:

1. AB-QM setting
2. CCR3+ Controller setting
3. Follow up

There are two main reasons that influence one-pipe system efficiency and therefore AB-QM and CCR3+ setting:

1. renovation status of the building since renovation is major reason for heating system to become oversized, generally, after building is renovated (wall & roof insulation, new windows) existing heating system becomes significantly oversized.
2. a dynamic nature of the heating load that is changing unpredictably in the building due to partial loads, internal gains and weather conditions.

Notes:

- Install temperature sensor in front of AB-QM and as close to last radiator in the riser/loop as possible.

- After renovation, it is important to optimize (reduce) flow temperature. Too high supply water temperature can influence radiators performance and result in oscillation of flow. In addition, optimized flow temperature improves efficiency of the one-pipe heating system. This procedure should consider the worst riser condition (big load, bad isolation etc).
- Ensure correct radiator a bypass flow setting (typically around 25-35 %). If the resistance of the radiator is much too high compared to the bypass this may result in underflow through radiator if the flow in riser/loop is reduced.

1. AB-QM setting

First it is necessary to set the AB-QM for required flow before the actuators is mounted. Required flow setting shall not be higher than calculated design flow value. Flow can be adjust according standard AB-QM setting recommendation from 20 % to 100 %.

2. CCR3+ controller setting

Return temperature setting should be done centrally on CCR3+ for all risers. To simplify setting procedure it is required to adjust only 9 return temperature points which correspondent to supply temperature, e.g: supply temp. 40 °C (required return temp. 38 °C), supply temp. 45 °C (required return temp. 40 °C), etc.

Settings (Continuous)

These settings will apply for risers. Later, if needed from menu we can choose option to change setting individually for each riser. Setting point can be moved up and down – according to request. This option allows in easy way adapting risers to individual demands.

For additional information about temperature choosing for nominal condition including Dynamic factor method please look in data sheet for thermostatic actuators QT, page 6.

For simplification CCR3+ Controller offers default setting (factory setting curve) that fits to typical renovated system based on EN 15316 and ISO 13790.

3. Follow up

Achieved energy efficiency of AB-QTE solution depends on CCR3+ Controller setting. For maximum results it is strongly recommended to perform follow up on the installation during first weeks of system operating. Easy access to setting from one central place (where CCR3+ Controller is installed) allows making any changes without extra cost and efforts!

Mounting

Actuators:
more details on data sheet TWA-Z

Temperature sensors:
more details on data sheet PT1000 (ESM, ESMB, ESMC, ESMT, ESMU)

***Note:** to compensate long distance from sensor to CCR3+ controller (additional cable resistance can influence accuracy of temperature measuring), please use correction factors according CCR3+ (see CCR3+ instructions). Cables shorter than 10 m (0,75 mm²) and 15 (1,00 mm²) do not require any correction.*

Temperature registration

The CCR3+ Controller can measure temperature with accuracy: $\pm 0,5$ °C.

Temperatures are measured by PT 1000 temperature sensors installed on the risers. If the CCR3+ is used solely for recording temperatures, it is not necessary to install any actuators on the AB-QM valves.

Sampling time (data collection) intervals can be adjusted using the control's keypad from 1 minute.

Data are stored on internal memory. The data collecting period depends strongly on and the sampling interval.

Data are saved in *.csv format and can be downloaded any time in Data menu.

The data can be visualised in spreadsheet and graphs.

Wiring, Dimensions and Installation

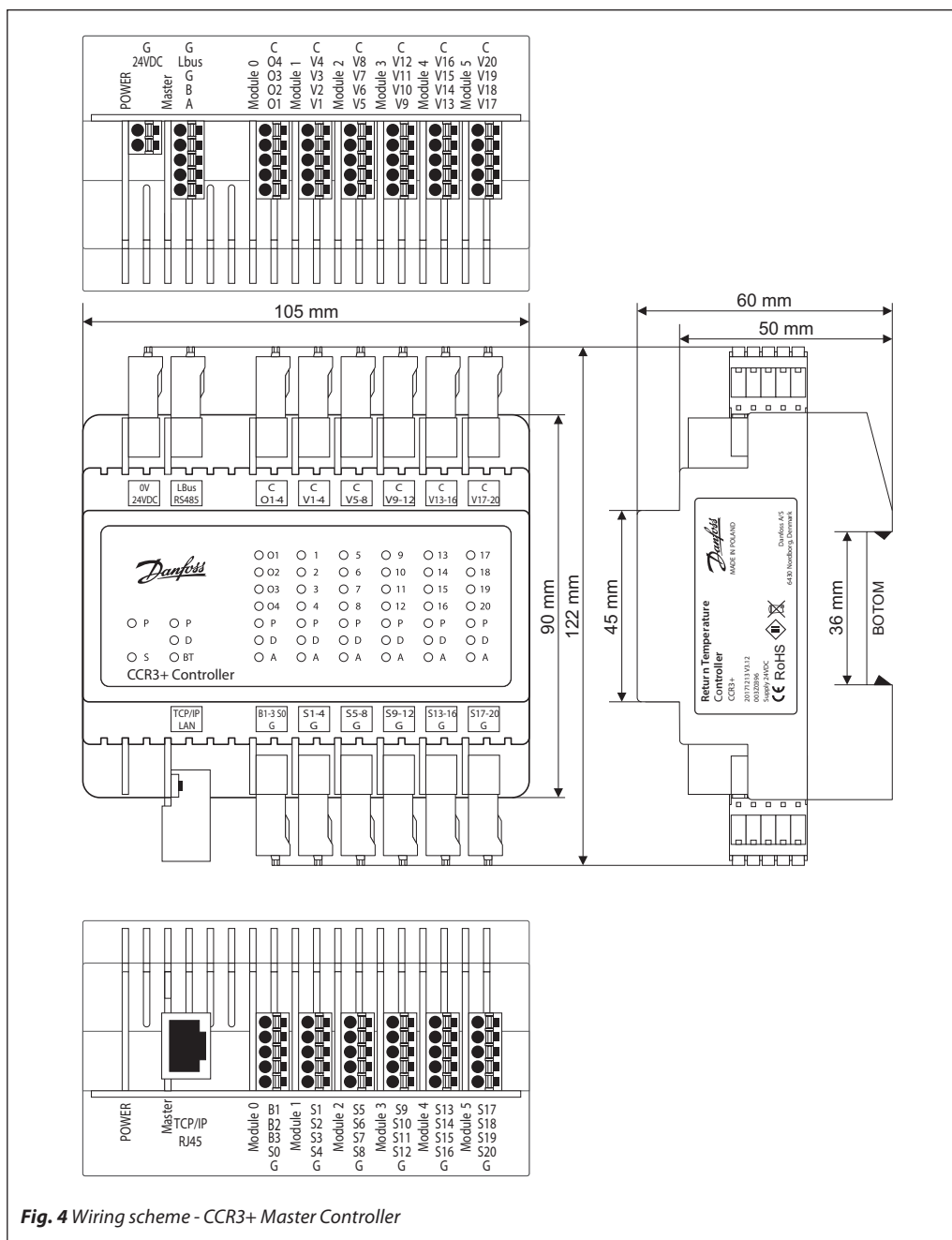

Fig. 4 Wiring scheme - CCR3+ Master Controller

Connector/port	Description
0V 24VDC	0V – ground (-) power supply 24VDC(+) power supply
Lbus RS485	G – ground Lbus port (for system expansion) Lbus – Lbus port (for system expansion) G – ground (Modbus RS 485) B – port B (Modbus RS 485) A - port A (Modbus RS 485)
C O1,..,O4	C – common port dedicated to outputs O1-O4 O1,..,O4 – defined outputs
C V1-4	C – common port dedicated to actuators V1-4 O1 - output: Alert Broken Sensor O2 - output: Alert Low Temp O3 - output: Alert High Temp O4 - output: not in use
C V5-8	C – common port dedicated to actuators V5-8 V5..V8 – outputs to actuators
C V9-12	C – common port dedicated to actuators V9-12 V9..V12 – outputs to actuators

Connector/port	Description
C V13-16	C – common port dedicated to actuators V13-16 V13..V16 – outputs to actuators
C V17-20	C – common port dedicated to actuators V17-20 V17..V20 – outputs to actuators
TCP/IP, LAN	TCP/IP port or IP Modbus port
B1-3, S0 G	B1,B2, B3 defined inputs S0 – temp. sensor G – common ground dedicated to inputs/sensor
S1-4 G	S1..S4 – inputs from sensors G – common ground dedicated to sensor S1-4
S5-8 G	S5..S8 – inputs from sensors G – common ground dedicated to sensors S5-8
S9-12 G	S9..S12 – inputs from sensors G – common ground dedicated to sensors S9-12
S13-16 G	S13..S16 – inputs from sensors G – common ground dedicated to sensors S13-16
S17-20 G	S17..S20 – inputs from sensors G – common ground dedicated to sensors S17-20

Wiring, Dimensions and Installation (Continuous)

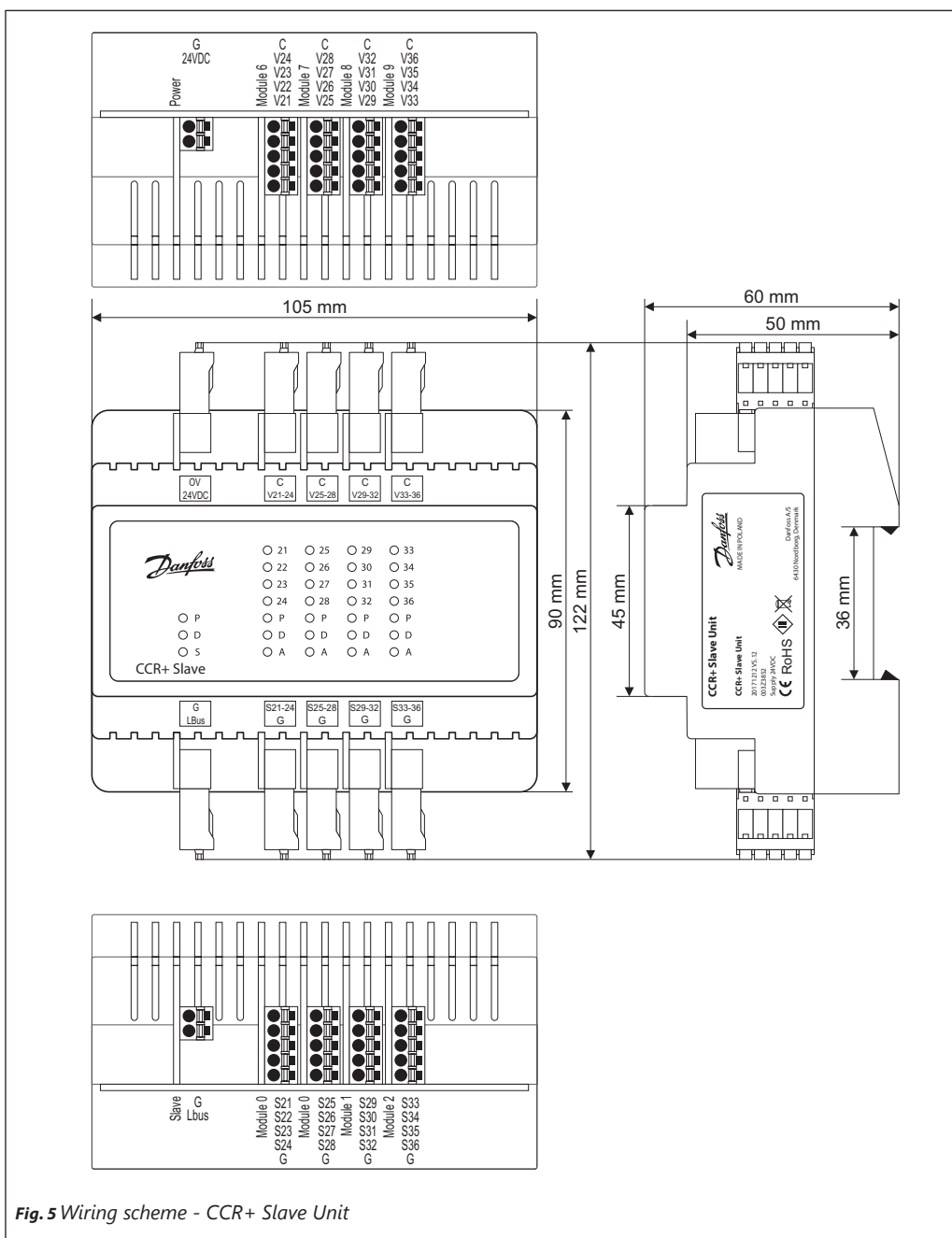
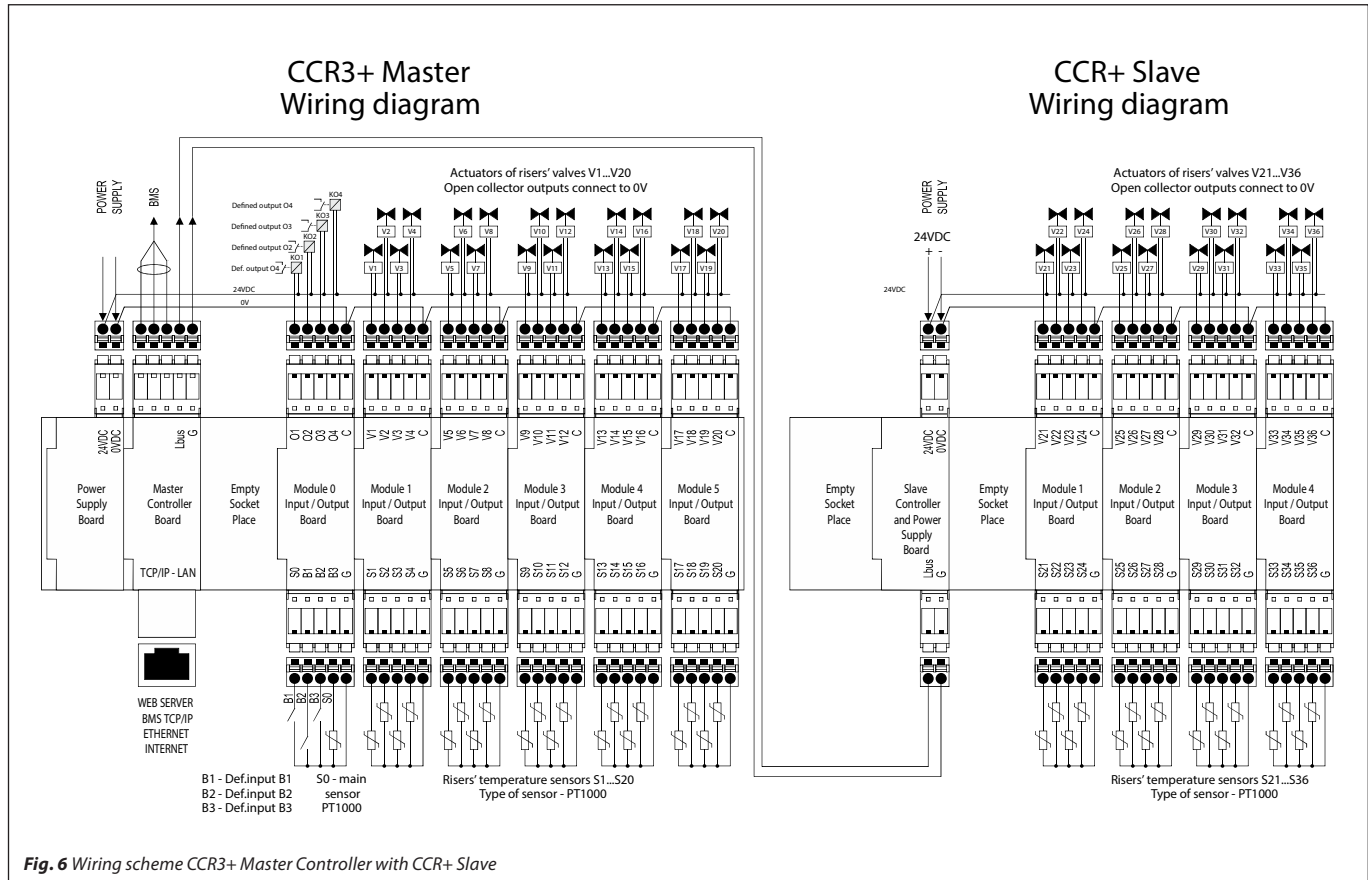

Fig. 5 Wiring scheme - CCR+ Slave Unit

Connector/port	Description
0V 24VDC	0V – ground (-) power supply 24 VDC power supply
C V21-24	C – common port dedicated to actuators V21..V24 – outputs to actuators
C V24-28	C – common port dedicated to actuators V24..V28 – outputs to actuators
C V29-32	C – common port dedicated to actuators V29..V32 – outputs to actuators
C V30-36	C – common port dedicated to actuators V33..V36 – outputs to actuators

Connector/port	Description
Lbus	G – ground Lbus port (for system expansion) Lbus – Lbus port (for system expansion)
S21-24 G	S21..S24 – inputs from sensors G – common ground dedicated to sensors
S25-28 G	S25..S28 – inputs from sensors G – common ground dedicated to sensors
S29-32 G	S29..S32 – inputs from sensors G – common ground dedicated to sensors
S33-36 G	S33..S36 – inputs from sensors G – common ground dedicated to sensors

Wiring, Dimensions and Installation (Continuous)



Tender text

- One-pipe heating systems should have electronic control of return temperature, based on supply temperature signal.
- Temperature curve should be adjusted in nine points from 35°C flow temperature up to 90°C.
- Control should base on: Return temperature controller, automatic balancing & control valve equipped with thermo actuators type TWA-Z 24V (NO) and remote temperature sensors type ESMC
- Controller allows return temperature control, monitoring and registering temperatures
- Maximum number of controlled branches is 20, system can be expanded with slave unit (+16)
- Controller allows connectivity with mobile devices and personal computers
- Controller should have "Summer mode" function (switchable in controller settings or via BMS) to shut-off flow on control valves when heating season is over.
- Controller allows connection to web browser (HTML) supported devices via Wi-Fi communication port or LAN port
- Controller support BMS systems via RS 485 Modbus RTU and IP Modbus
- Unauthorized change of controller setting is secured by password
- Controller should have Pulse Wide Modulation (PWM) algorithm
- Build in pump protection function
- Controller can measure temperature with accuracy: ±0,5 °C.
- Supply Voltage: 24V DC 50/60H

Danfoss A/S

Heating Segment • heating.danfoss.com • +45 7488 2222 • E-Mail: heating@danfoss.com

Danfoss can accept no responsibility for possible errors in catalogues, brochures and other printed material. Danfoss reserves the right to alter its products without notice. This also applies to products already on order provided that such alterations can be made without consequential changes being necessary in specifications already agreed. All trademarks in this material are property of the respective companies. Danfoss and all Danfoss logotypes are trademarks of Danfoss A/S. All rights reserved.