

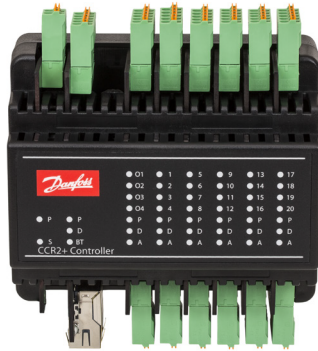

Operating Guide

# CCR2+ Controller



Master Controller

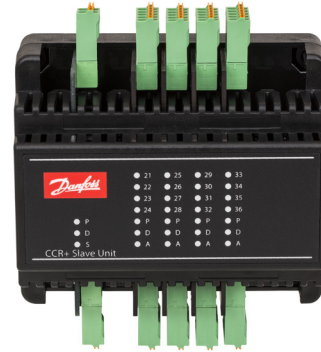

Slave Unit

ENGLISH

CCR2+ Disinfection Process Control & Temperature Registration

[www.danfoss.com](http://www.danfoss.com)



CCR2+ Controller

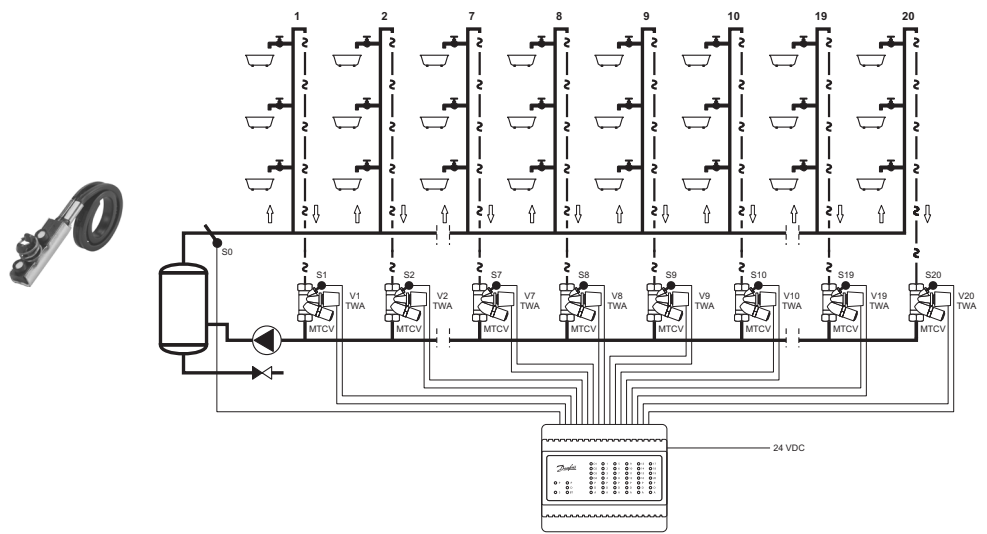
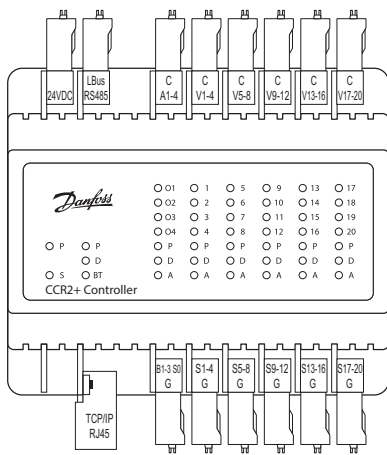

Fig. 1 CCR2+ & ESMC

Fig. 2 Installation with CCR2+ Controller (up to 20 risers/loops)

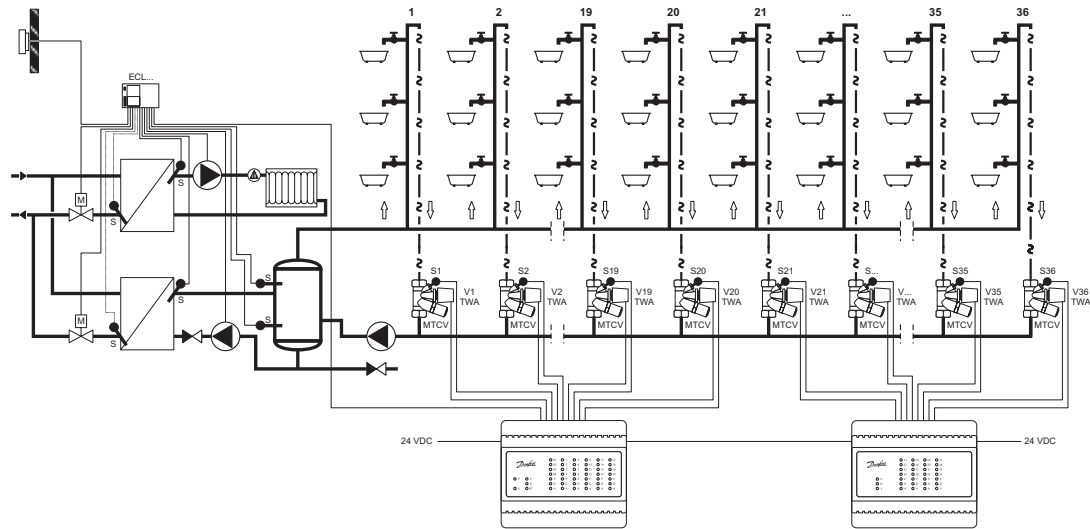

Fig. 3a Installation with CCR2+ Controller (Master) and CCR+ Slave Unit (more than 20 risers)

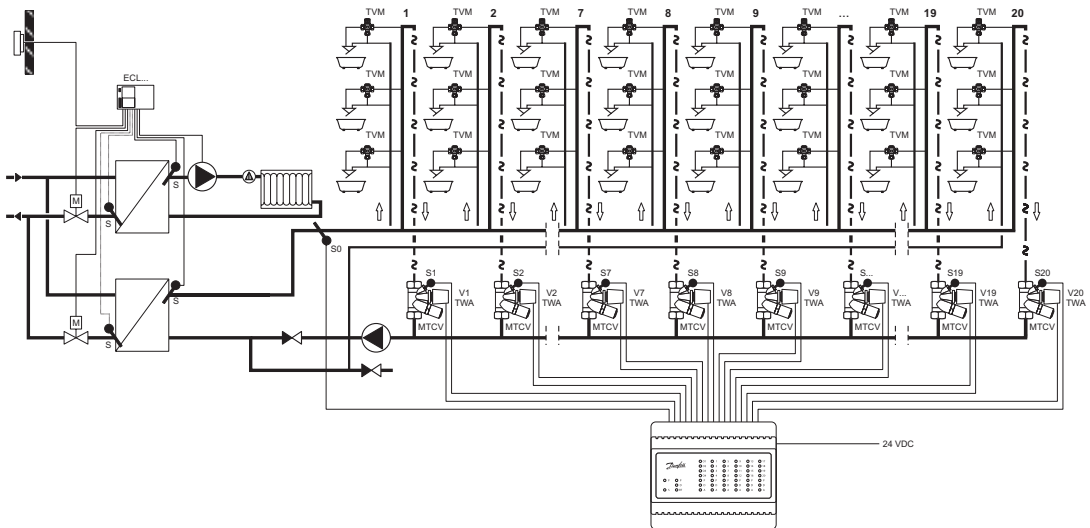

Fig. 3b

## CCR2+ Controller

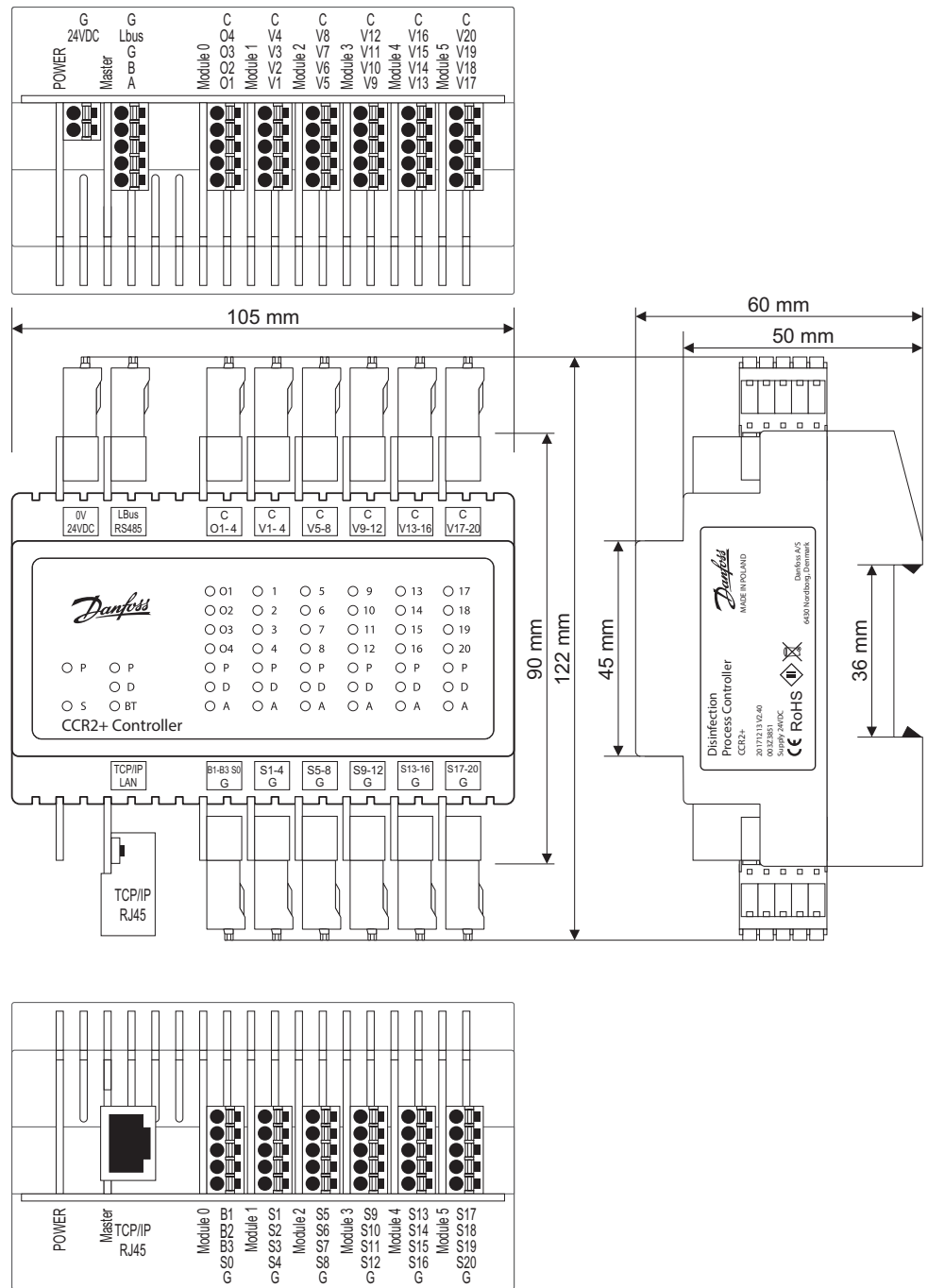

Fig. 4a Wiring scheme - CCR+ Master Controller

Connector/port	Description
<b>0V 24VDC</b>	<b>0V</b> – ground (-) power supply <b>24 VDC(+)</b> power supply
<b>Lbus RS485</b>	<b>G</b> – ground Lbus port (for system expansion) <b>Lbus</b> – Lbus port (for system expansion) <b>G</b> – ground (Modbus RS 485) <b>B</b> – port B (Modbus RS 485) <b>A</b> – port A (Modbus RS 485)
<b>C O1,...,O4</b>	<b>C</b> – common port dedicated to outputs O1-O4 <b>O1</b> - output: Heat Force <b>O2</b> - output: Start next CCR/Slave Unit <b>O3</b> - output: Disinfection finished <b>O4</b> - output: Alarm
<b>C V1-4</b>	<b>C</b> – common port dedicated to actuators V1-4 <b>V1..V4</b> – outputs to actuators
<b>C V5-8</b>	<b>C</b> – common port dedicated to actuators V5-8 <b>V5..V8</b> – outputs to actuators
<b>C V9-12</b>	<b>C</b> – common port dedicated to actuators V9-12 <b>V9..V12</b> – outputs to actuators

Connector/port	Description
<b>C V13-16</b>	<b>C</b> – common port dedicated to actuators V13-16 <b>V13..V16</b> – outputs to actuators
<b>C V17-20</b>	<b>C</b> – common port dedicated to actuators V17-20 <b>V17..V20</b> – outputs to actuators
<b>TCP/IP, LAN</b>	<b>TCP/IP</b> port or IP Modbus port
<b>B1-3, S0 G</b>	<b>B1, B2, B3 defined inputs</b> <b>S0</b> – temp. sensor <b>G</b> – common ground dedicated to inputs/sensor
<b>S1-4 G</b>	<b>S1..S4</b> – inputs from sensors <b>G</b> – common ground dedicated to sensor S1-4
<b>S5-8 G</b>	<b>S5..S8</b> – inputs from sensors <b>G</b> – common ground dedicated to sensors S5-8
<b>S9-12 G</b>	<b>S9..S12</b> – inputs from sensors <b>G</b> – common ground dedicated to sensors S9-12
<b>S13-16 G</b>	<b>S13..S16</b> – inputs from sensors <b>G</b> – common ground dedicated to sensors S13-16
<b>S17-20 G</b>	<b>S17..S20</b> – inputs from sensors <b>G</b> – common ground dedicated to sensors S17-20

# CCR2+ Controller

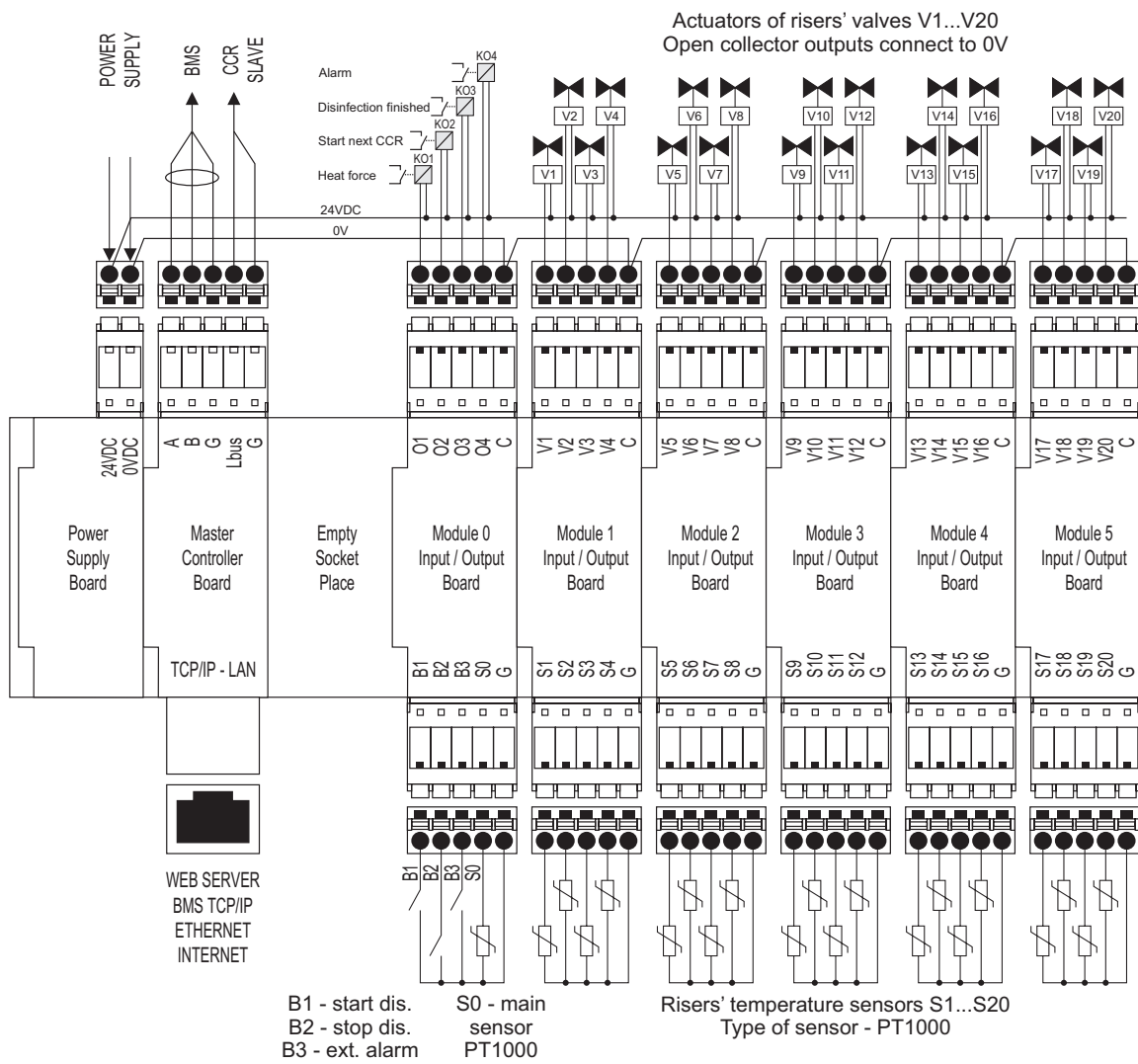

Fig. 4b Wiring scheme CCR2+ Master Controller

## CCR2+ Controller

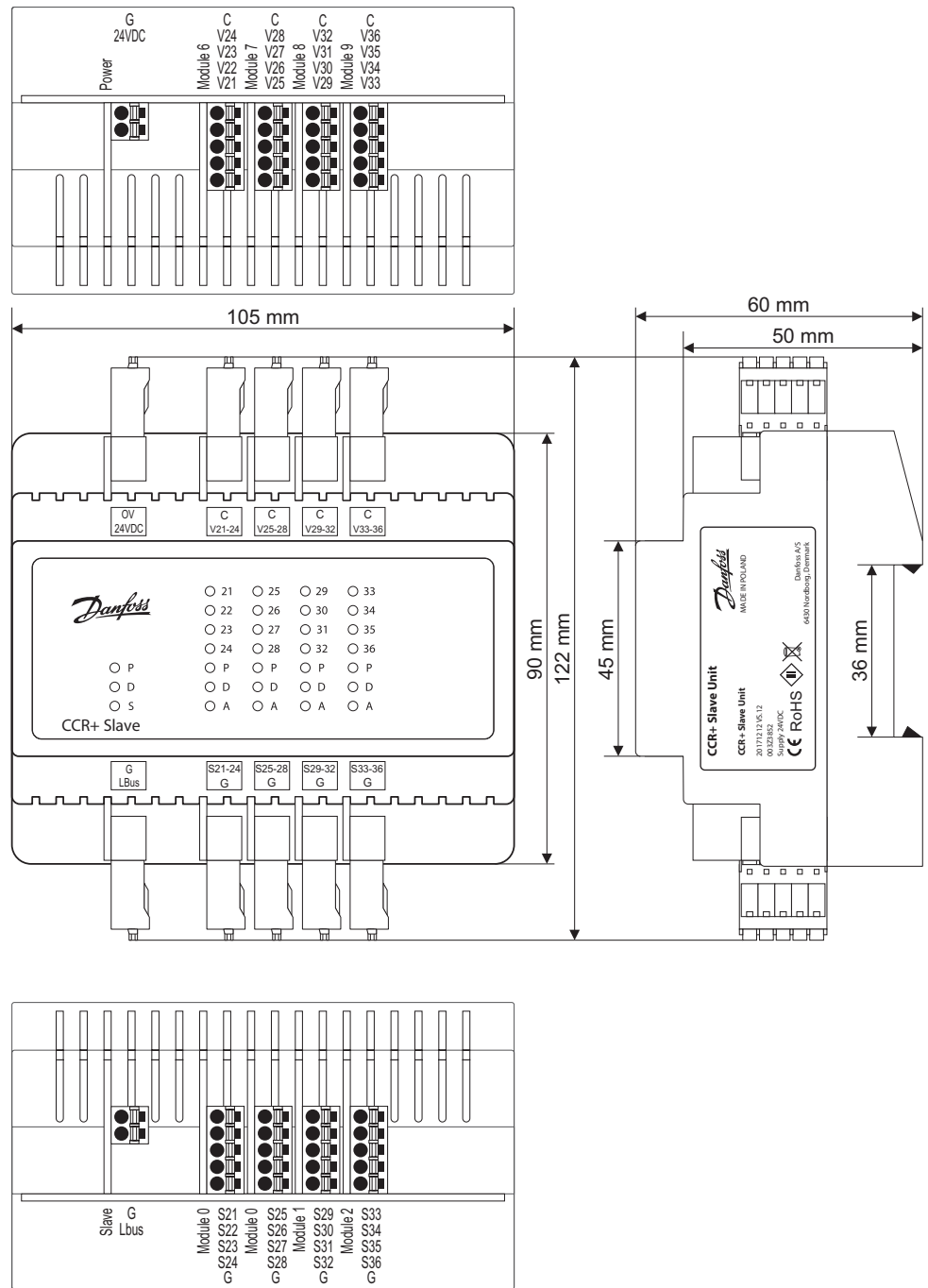
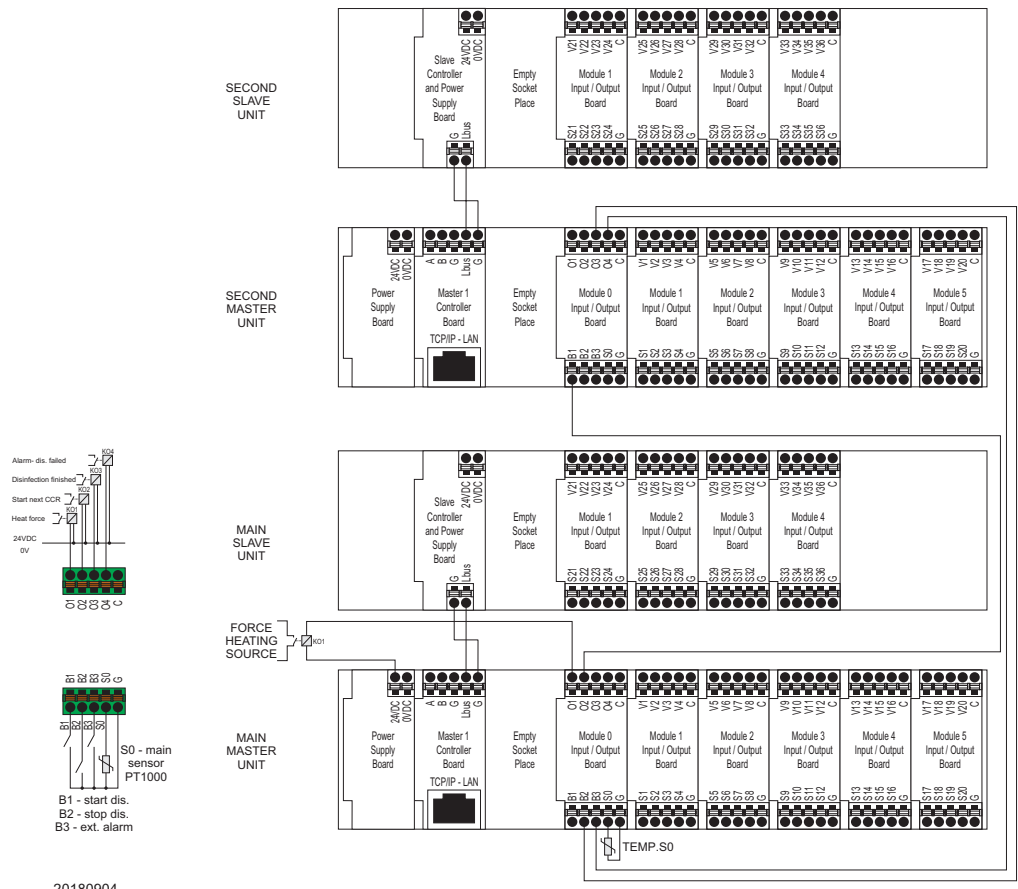

Fig. 5 Wiring Scheme - CCR+ Slave Unit

Connector/port	Description
0V 24VDC	0V – ground (-) power supply 24 VDC power supply
C V21-24	C – common port dedicated to actuators V21..V24 – outputs to actuators
C V24-28	C – common port dedicated to actuators V24..V28 – outputs to actuators
C V29-32	C – common port dedicated to actuators V29..V32 – outputs to actuators
C V30-36	C – common port dedicated to actuators V33..V36 – outputs to actuators

Connector/port	Description
Lbus	G – ground Lbus port (for system expansion) Lbus – Lbus port (for system expansion)
S21-24 G	S21..S24 – inputs from sensors G – common ground dedicated to sensors
S25-28 G	S25..S28 – inputs from sensors G – common ground dedicated to sensors
S29-32 G	S29..S32 – inputs from sensors G – common ground dedicated to sensors
S33-36 G	S33..S36 – inputs from sensors G – common ground dedicated to sensors

# CCR2+ Controller



**Fig. 6** Connection of two CCR2+ with one S0 sensor in sequence mode

20180904

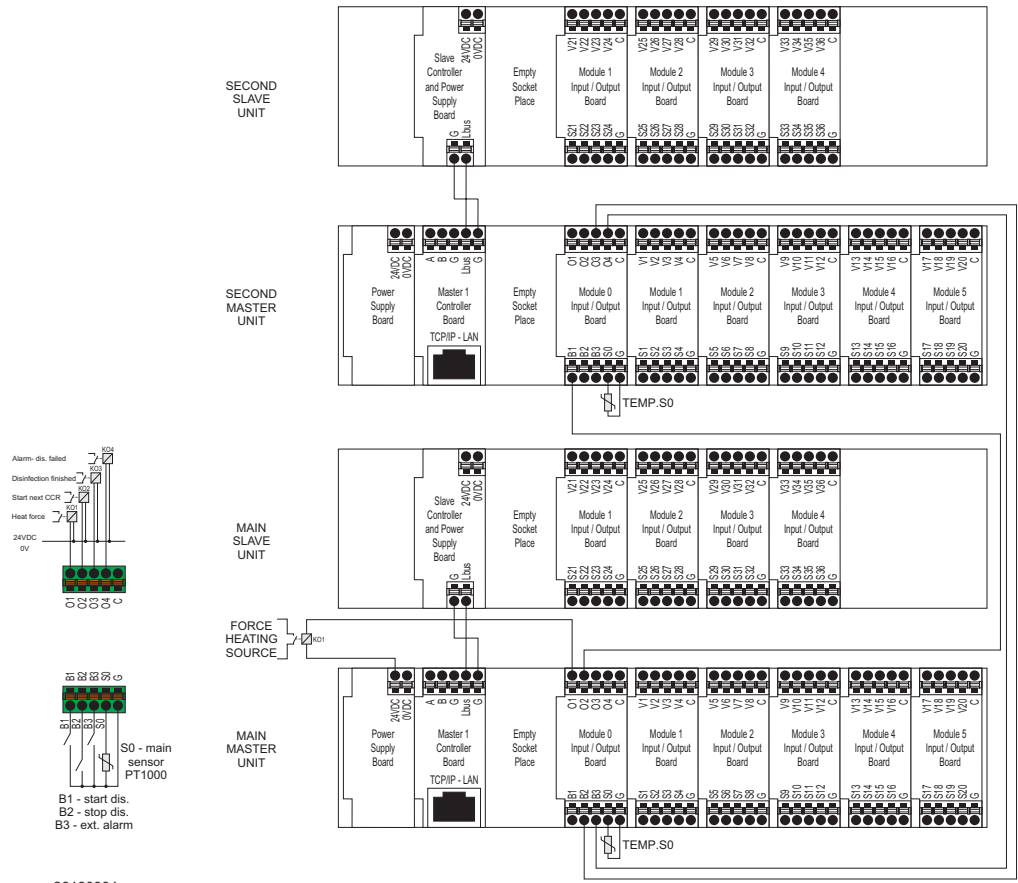

**Fig. 7** Connection of two CCR2+ with individual S0 sensor in sequence mode

20180904

# CCR2+ Controller

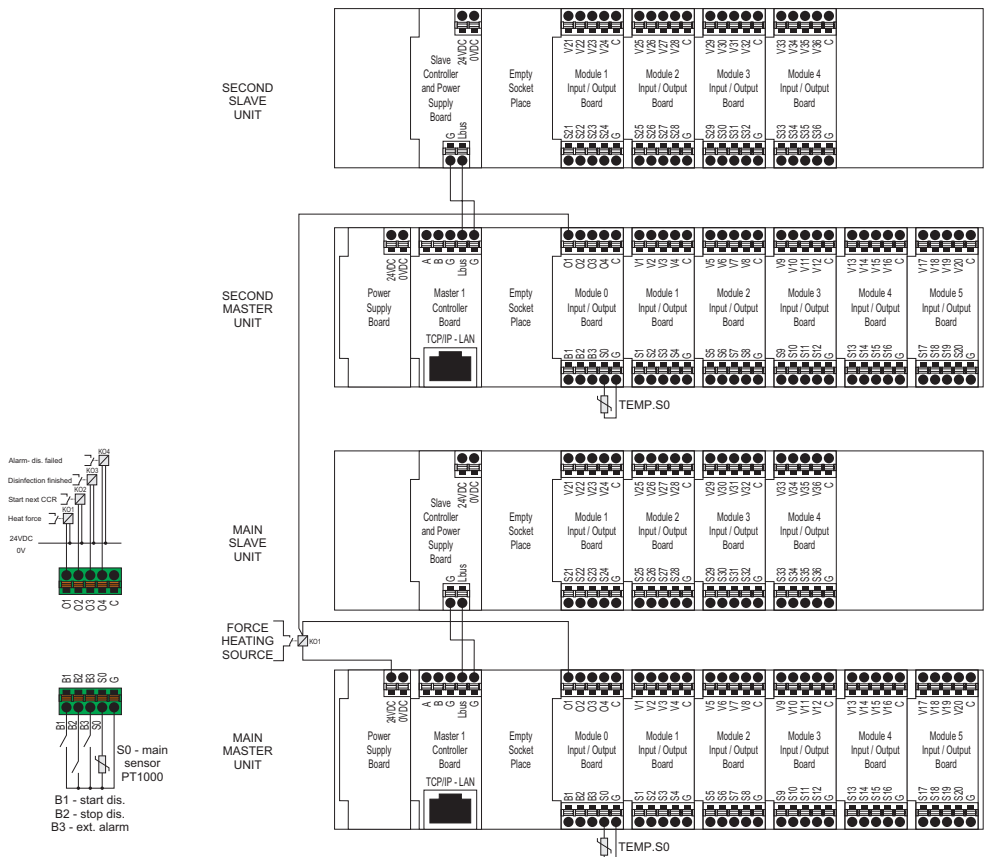

**Fig. 8** Connection of two CCR2+ with individual S0 sensor in parallel mode

20180904

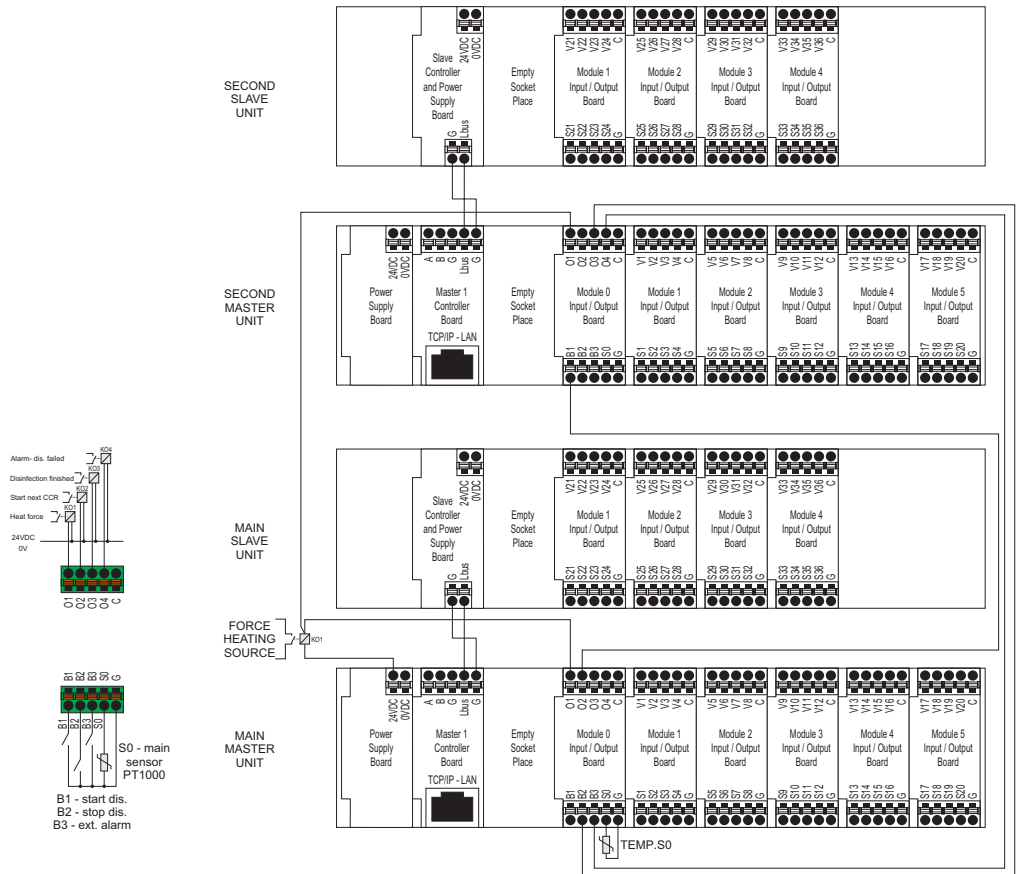

**Fig. 9** Connection of two CCR2+ with one S0 sensor in parallel mode

20180904

## CCR2+ Controller

### 1. Product description

The CCR2+ is a control used for optimizing the thermal disinfection process in hot water systems with functions such as temperature registration and monitoring circulation hot water systems. The control is connected to thermo

actuators type TWA-A and remote temperature sensors PT1000, type ESMB, installed on each thermostatic circulation valve, type MTCV (Multifunctional Thermostatic Circulation Valve).

### 2. Technical data

Temperature sensor (S0, S1-S20 / S21-36)	Pt1000, S0- type ESMC / ESM11, S1 ... S36 – type ESMB
Temperature range (registration)	-20 °C ... +120 °C
Measuring accuracy	± 0,1 K
Inputs: B1, B2 and B3	Free contact (5 V 1 mA)
Number of control valves (risers)	20, additional 16 with system extension via CCR+ Slave Unit
Output signal to actuators	24 VDC max. 1 A
Alarm signal output	24 VDC max. 1 A
Relay output	0 ... 24 DC max. 1 A
Type of memory	Build-In
Capacity of memory	8 GB
Timer: Real time clock	Built-in battery - service life 10 years
Communication interfaces	- Wi-Fi (communication port only) - TPC/IP port (LAN cable connection) - Modbus RS485 RTU - IP Modbus (LAN cable connection)
Default IP settings	- Default LAN IP address (static): 192.168.1.100 - Default WiFi access IP address (static): 192.168.1.10 - IP address mask: 255.255.255.0 - Gateway address: 192.168.1.1 - DNS address: 192.168.1.1 - CCR name: ccrplus - default password: admin1234
Ambient temperature	0 ... 50 °C
Transport temperature	-10 ... +60 °C
IP rating	IP 20,
Power supply	24 VDC
Power consumption (Master controller only) <sup>1)</sup>	10 VA
Power consumption (Slave Unit only) <sup>1)</sup>	3 VA
Weight	0.3 kg
Installation	DIN rail 35 mm

<sup>1)</sup> To select proper power transformer please follow formula: 24 V 10VA (controller) + 7 VA\*/per each actuator

### 3. Installation

For easy access, the CCR2+ controllers should be installed in electrical enclosure on DIN rail 35 mm. Enclosure with DIN rail should be mounted onto the wall (sub - station or boiler room) as close as possible to the heat source. DIN rail and enclosure are not included.

It is recommended to install the standard 24 VDC transformer in the same box as CCR2+ (not supply). The transformer power depends on numbers of actuators (number of risers in heating installation). To select proper power transformer please follow formula: 24 V 10VA (controller) + 7 VA\*/per each actuator

Example (building with 20 risers):  
10VA (for controller) + 7VA x 20 actuators = 150VA

## CCR2+ Controller

### 4. Switching the control on

Before switching the control on for the first time, disconnect all cables and connect a 24 VDC source to the disconnected power plug. Use a voltmeter to measure the voltage on the power cable plug before it is connected to the control. If the voltage is correct:

1. Read the instructions before you operate the control
2. Disconnect all cables
3. Connect the power to the transformer (not connected to CCR2+)
4. Turn on the power to the transformer
5. Verified currency - 24 VDC
6. Connect the cable from the transformer to the CCR2+ input

The LED diodes on device should blink at start-up.

Before any plugs are connected to the control's, input and output connectors:

1. Set all parameters on the controller
2. Make sure that there is no external voltage on the temperature sensor plugs
3. Make sure that the voltage on the relay contacts is not too high (max. 24 VDC)

### 5. Switching on

When controller is connected to power, LED indicator start to blink. The meaning of LED status is:

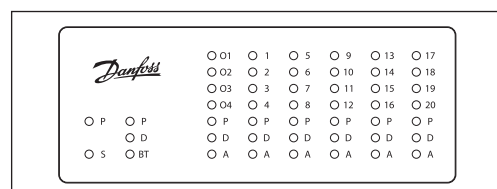

LED	Description
<b>P (orange)</b> – Power inside controller (+5V)	Lights when DDC PCB is power on
<b>D (white)</b> – Data transfer indicator for LAN	Blink when DDC is communicating by TCP/IP
<b>S (orange)</b> - Input power indicator (24VDC)	Lights when power supply PCB is working
<b>BT (blue)</b> – Basic transmission indicator for Wi-Fi	Blink when DDC is communicating by WiFi
<b>A (red)</b> – Alert status on I/O module	LED lights when/if: to low temp., broken sensor
<b>O1..4 ; 1-20 (green)</b> – Digital Output Status	Lights when Output is closed to 0V

### 6. Types of Logins and Access

Controller has a built in WEB Server App to communicate with all devices with html browsers via following communication interfaces:

- Wi-Fi communication port
- LAN cable connection (TCP/IP port)

### 7. Wi-Fi settings (no cable needed - recommended for all types of devices)

1. Enter Wi-Fi settings
2. Switch on Wi-Fi
3. Scan for Wireless Network Connection
4. Select CCRplus
5. Enter password (default is »admin1234«)

### 8. Local Network settings (only for LAN cable connection with PC)

1. Go to »Local Network settings«
2. Go to »Properties« -> »Internet Protocol Version 4 (TCP/IPv4)
3. Configure IP address:

4. Confirm with »OK« and close menu in PC.

9. RUN CCR2+ APPLICATION

Launch your browser from a computer or wireless device that is connected to the CCR2+. Tap the IP address into web browser window:  
 1. Wi-Fi access: Type 192.168.1.10 into Web Browser  
 2. LAN connection: Type 192.168.1.100 into Web Browser  
 CCR2+ application will open.

For 1st login enter password »admin1234«

IMPORTANT: Change of password to secure any unauthorized interaction from 3rd parties

NOTE: You can Skip login for access to data only in CCR+ (reading, overview only)

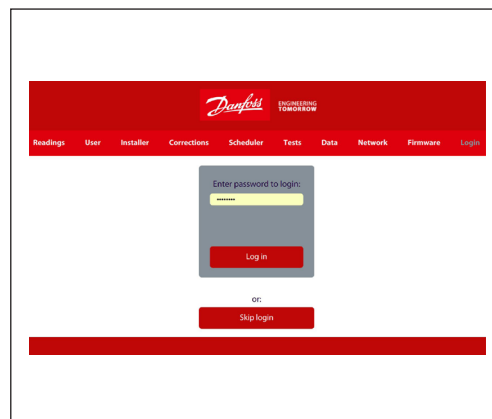

10. CCR2+ DASHBOARD (Web App Screen)

When the setup and is complete, the reading display will be shown on the screen.

The Basic CCR2+ App screen has a dashboard that offer plenty of status overview, basic and advanced settings. The manufacturer reserves the right to change Firmware in production to improve handling and functionality. An up - to - date list of settings for the given firmware is available on the Danfoss website. New settings can automatically upgrade according to guidelines in instruction.

- **Readings:** Informations about basic settings, device status, current time and date, storage capacity
- **User:** Basic disinfection settings
- **Installer:** Advanced and service settings
- **Corrections:** Temperature sensor calibration settings
- **Scheduler:** Schedule settings
- **Tests:** Device outputs testing tool
- **Data:** Access to Data log file
- **Network:** BMS and IP/TPC settings
- **Firmware:** Firmware upgrade tool
- **Login:** Login option

READINGS MENU:

No.	Name	Description
1	Scheduler	Open – Schedule programme active Close - Scheduler programme not active
2	S0-main temp.	S0 – value of (°C) supply temperature. The same readings apply to sensors S1 ... S20. <b>Open</b> - no sensor or break sensor circuit <b>Closed</b> – shortcut to ground in sensor circuit If the S0 is disinfection source, statutes are shown in color: - Grey: S0 is start disinfection source - Red: S0 temp. is OK(greater than disinfection temp.) - Blue: S0 temp. is too low during disinfection process (lower than disinfection temp) - Yellow: S0 temp. sensor is broken
3	B1-start dis.	Input status B1 - G <b>Open</b> – input B1 open <b>Close</b> – input B1 close to G If the B1 is disinfection source, statutes are shown in grey color. Function is used in parallel and sequences connection.
4	B2-stop dis.	Input status B2 - G <b>Open</b> – input B2 open <b>Close</b> – input B2 close to G Close (shortcut B2-G) always finished disinfection process. The end of the disinfection process can be realised automatically (look to: Advanced Menu – This is Master) or manually if it is necessary to stop the process. When it is done manually, system reset all previous screen information (faults).
5	B3-ext. alarm	Information about external fault(used in sequence mode to indicate errors on primary CCR2+ master)
6	Trigger timeout	To be used when input B1 source is not stable (f.ex. thermostat switch, or S0 temp. source is not stable) Timer will start to count down the disinfection timeout when B1 is open or. S0 temp. is less that Dis.Set.Temp. Timer is reseted if S0 temp. is higher that Dis.Set.Temp. or B1 input is closed. In case of timeout count down to 0, disinfection will be stopped with timeout fault.
7	"Days left	How much data can be stored per day in the system memory (for actually settings)
8	RT Clock	The Real Time clock, show current time, date, day of the week Data used in archive file and scheduler.

## CCR2+ Controller

### 10. CCR2+ DASHBOARD (Web App Screen) (continuous)

No.	Name	Description
9	Disinfection	Disinfection mode: Is disinfection permitted? Choice between: <b>Enable</b> – disinfection is permitted <b>Disable</b> – disinfection is switched off in settings
10	Dis. Set. Temp.	The setted disinfection temperature (look to: User Menu) The relations between temperature and corresponding time is provided from the Brunette Resources reference table.
11	Dis. time [HH:MM]	Disinfection time in the risers. Disinfection time countdown is independent for each riser (look to: User Menu). Timer is counting when riser temp. is bigger then Dis. Set. Temp.  Minimum required and maximum recommended time depend on the disinfection temperature and should be selected from the Brunett Resources reference table.
12	Min. divide adv. (%)	Dividing risers into groups If dividing is Enable, system is counting progress of disinfection of active risers, between divide time period. If in divide time period progress of disinfection is less than Min. divide, adv. active risers will be automatical divided to half. New active group will continue with most promising (hottest) risers.
13	Divide time	Group division period If dividing is Enable, Controller will calculate the average disinfection progress of active risers, between Divide time than Min. divide adv. Active risers will be automatical divided to half. New active group will continue with most promising (hottest) risers. <b>Factory setting: 20 min</b>
14	Circ. Set Temp.	Electronically controlled circulation temperature after disinfection in riser. Controller can maintain the requested circulation temperature in the riser after the disinfection process. This function is recommended for control valves with only actuators (PI control signal). For self - acting valves like MTCV (with basic thermostat element) recommended setting is 5 °C. <b>Factory setting: 5°C</b>
15	O1-heat force	Outputs status: <b>Open</b> – when disinfection is not active <b>Close</b> – when disinfection is in progress
16	O2-start next	Outputs status: <b>Open</b> – when disinfection is not in progress or not finish <b>Close</b> – when disinfection is finished in sequence mode
17	Disinfection	Disinfection process is enabled or disabled. (can be changed in User menu->Disinfection)
18	Total Dis.Adv	Advance of Disinfection progress, calculated from all (active and non active) risers.
19	Dis. timeout	Time to finish
20	Divide adv.	Advance of Disinfection progress, calculated from active risers. After divide time period, Divide adv. Is compared to Min.Divide adv. If Divide adv. is less than Min.Divide adv. risers will be divided to half.
21	Divide timeout	Time left to compare Divide adv. and Min.Divide adv. to make decision about divide risers.
22	Ris. in group	Number of risers in the currently disinfected group. If no division was made, this is the total number of risers. Option of choice divides risers into groups during disinfection or is used in Installer Menu. Function: To be used division enables disinfection process to accelerate in extensive hot water circulation installations.
23	O3-dis. finished	Outputs status: <b>Open</b> – O3 is closed to common (C) <b>Close</b> – shortcut to common (C)
24	O4-alarm	Outputs status: <b>Open</b> – O4 is closed to common (C) <b>Close</b> – shortcut to common (C)
<b>Riser Status</b>		
25	Riser	Order number of risers (look to: Installer Menu) Number of riser in risers status section <b>Open</b> - no sensor or break sensor circuit <b>Closed</b> – shortcut to ground in sensor circuit  Riser statuses are indicated with color. - <i>White</i> : non relevant (disabled in Installer->risers number) risers - <i>Red</i> : Disinfection in process, all temperature is OK - <i>Blue</i> : Disinfection in process but riser temperature is lower than Dis.Set.Temp - <i>Yellow</i> : if Sn temp. sensor or cable is broken
26	Valve output	Status of valve: V1 ... V36 <b>1</b> – valve is open in % shown in Valve [%] column. <b>0</b> – valve is closed Valve [% ] = 0%. Status 1 is shown when valve open ratio is more than 0%.
27	Valve [%]	% of opening of valve (V1 ... V36) in PWM mode
28	Temperature [°C]	Temperature readings in riser Sensor S1,..., S36 temperature <b>Open</b> - no sensor or break sensor circuit <b>Closed</b> – shortcut to ground in sensor circuit
29	InGroup	Place in ranking of disinfection progress of risers (at dividing period system will continue disinfection with best ranking risers)
30	Disinfection	% of riser disinfection progress
31	Time to end [HH:MM]	Count down timer is counting when temp. on riser is higher that Dis.Set.Temp. After timer count down to zero, riser is disinfected successfully.

**10. CCR2+ DASHBOARD**  
**(Web App Screen)**  
 (continuous)

No.	Name	Description
32	Dis. status	Riser Rx – riser status information: <b>-OK:</b> disinfection finished successfully <b>-DisFault:</b> disinfection has failed in riser Rx <b>-SensFaultL:</b> temperature too low or sensor or shortcut to ground in sensor circuit <b>-SensFaultH:</b> temperature too high or no sensor or break sensor circuit <b>-LowTemp:</b> temperature too low to perform disinfection <b>-InProcess:</b> disinfection in process

**USER MENU:**

No.	Name	Description
33	Disinfection	Is disinfection permitted? Possible choices: <b>Enable</b> – disinfection permitted <b>Disable</b> – disinfection is switched off
34	Disinfection temperature	Set disinfection temperature. Disinfection is initiated when the temperature on sensor S0 exceeds the set temperature. Exceeding the set temperature on a riser sensor (S1 ... S20), triggers the disinfection time countdown for the given riser. <b>Factory setting: 65°C</b>
35	Disinfection time	Set disinfection time in the risers. Disinfection time countdown is independent for each riser. Minimum required and maximum recommended time depend on the disinfection temperature and should be selected from the table in chapter »Temperature set in the circulation risers and disinfection time« <b>Factory setting: 15min</b>
36	Circulation temperature	Electronically controlled circulation temperature after disinfection in riser. The CCR2+ can maintain the requested circulation temperature in the riser after the disinfection process. This function is recommended for control valves with only actuators (PI control signal). For self-acting valves like MTCV (with basic thermostat element) recommended setting is 5 °C. <b>Factory setting: 5°C</b>
	Save Settings	Click »Save Settings« to confirm changes

**INSTALLER MENU:**

No.	Name	Description
37	Divide group	Dividing risers into groups: <b>Enable</b> – when the disinfection progress is slower than the set progress in MinAdvan <b>Disable</b> – switched off regardless of the disinfection progress <b>Factory setting: Enable</b>
38	Divide time	Group division period. If dividing is Enable, Controller will calculate the average disinfection progress of active risers, between Divide time period. If in divide time period progress of disinfection is less than Min. divide adv. Active risers will be automatical divided to half. New active group will continue with most promising (hottest) risers. <b>Factory setting: 20 min</b>
39	Min. divide adv. (%)	Dividing risers into groups If dividing is Enable, system is counting progress of disinfection of active risers, between divide time period. If in divide time period progress of disinfection is less than Min. divide adv. Active risers will be automatical divided to half. New active group will continue with most promising (hottest) risers.
40	Risers number	Number of risers connected to the CCR2. <b>Factory setting: 20</b>
41	CCR System	Function used for big systems. System expansion is done with several CCR2+ Controllers (with connected CCR+ Slave Unit on each), which are connected: <b>Sequence</b> – disinfection step by step (first primary CCR2+ Master with CCR+ Slave Unit, then secondary CCR2+ Master with CCR+ Slave Unit, etc). If disinfection signal appears, the disinfection process starts only in primary CCR2+ Master (with Slave Unit) and after implementation (successful performed or not), output O2 becomes shortcut with C, which allows the start of the process in secondary CCR2+ Master (with Slave Unit). When the last riser is disinfected, the primary CCR2+ Master will send a signal to ECL (or another control) and the supply disinfection temperature returns to comfort temperature. <b>Parallel</b> – disinfection is performed at the same time. If disinfection signal appears, output O2 becomes shortcut with C. This is the signal for CCR2+ to start the disinfection. Parallel function allows the start of the disinfection in all system (all CCR2+ with CCR+ Slave Units in the same time). Main CCR2+ Master revokes the disinfection order for other CCR2+s (with CCR+ Slave Units). <b>Factory setting: Parallel</b>
42	Integration time	Integration time of the disinfection temperature (and circulation temperature) sustenance process in risers controlled by MTCV valves. The shorter the time, the quicker temperature changes (no stabile regulation). The longer the time, the slower reaction for temperature changes (stable regulation). <b>Factory setting: 60 sec</b>
43	Proportional factor	Proportional factor of the disinfection temperature regulation (and circulation temperature) in risers is controlled by MTCV valves. The higher Proportional factor will effect in the bigger valves reaction (no stabile regulation). The lower Proportional factor, the weaker reaction for temperature change (stable regulation). <b>Factory setting: 100</b>
44	Required temperature	Information about Temperature in installation (for BMS alarming only). Setting range between +10 °C and +100 °C. This setting is used for temperature alarm output when real temperature in system exceed upper and lower deviation count from Required Temperature. <b>Factory setting : 55 °C</b>

## CCR2+ Controller

### 10. CCR2+ DASHBOARD (Web App Screen) (continuous)

No.	Name	Description
45	Dif. Temp +	Set upper deviation temperature counted from Required Temperature. Temperature alarm output indicated signal when temperature exceed this range. Setting range between +1 °C and +20 °C <b>Factory setting: +10°C</b>
46	Dif. Temp	Set lower deviation temperature counted from Required Temperature. Temperature alarm output indicated signal when temperature drop below this range. Setting range between -1 °C and -20 °C <b>Factory setting: -10°C</b>
47	Alarm Delay	Set Alarm Delay. The temperature alarm delay when real temperature exceed exceed upper and lower deviation counted from Required Temperature. Setting range between 0 minute and 100 minute <b>Factory setting : 10 min</b>
48	Alert relay type	Alarm output: <b>StillOn</b> – continuous alarm signal <b>Pulse</b> – pulse alarm signal 24 VDC every second <b>Factory setting: Pulse</b>
49	Archive frequency	Data archiving interval. The time can be set to any value between 10 seconds and 4 hours. <b>Factory setting: 1 min</b>
50	DisSources	Disinfection sources for running disinfection and continuing the process, There are a few combinations which allow initiation of the process based on one signal or in relation to many needed signals.  Disinfection is initiated when: - <b>S0</b> : sensor S0 reports a temperature higher than the disinfection temperature - <b>B1</b> : input shorted to ground, - <b>S0+SCH</b> : sensor S0 reports a temperature higher than the disinfection temperature in the scheduled time period, - <b>B1+SCH</b> : B1 input shorted to G (ground) in the scheduled time period, SCH - weekly schedule runs and continues until it is complete, even if schedule was to terminate it, - <b>SCH</b> : weekly schedule runs and continues until it is complete, even if schedule was to terminate it, - <b>S0/B1+SCH</b> : B1 input shorted to G (fault to frame, ground) or sensor S0 reports a temperature higher than the disinfection temperature in the scheduled time period, - <b>S0&amp;B1</b> : B1 input shorted to G and sensor S0 reports a temperature higher than the disinfection temperature, - <b>S0&amp;B1+SCH</b> : B1 input shorted to G and sensor S0 reports a temperature higher than the disinfection temperature in the scheduled time period. <b>Factory setting: S0</b>
51	DisSources type	Relevant for input: <b>StillOn</b> – Disinfection is started when input contact is shorted to M <b>Pulse</b> – Disinfection is started by short pulse of input contact to M <b>Factory setting: Pulse</b>
52	Date format	Form of date display: <b>YY - MM - DD</b> – year, month, day <b>YY - DD - MM</b> – year, day, month <b>DD - MM - YY</b> – day, month , year <b>MM - DD - YY</b> – month, day, year <b>Factory setting: YY - MM - DD</b>
53	CCR is	Status of CCR2: <b>Register</b> - functions as temperature registration <b>Reg+Dis</b> - functions as disinfection control with registration <b>Factory setting: Reg+Dis</b>
54	Current time	Sets the real time »Clock, hour & minutes“
55	Current date	Sets the real date »Day, Month, Year“
56	Start risers number	Setting is active, when dividing is Enable Controller start disinfection with less number of risers set in »Start riser number«. Rest of risers are not active. When disinfection in started risers is finished, rest of risers are sequently activated and disinfected. If disinfection progress is less that Min.Div.Adv., risers will be divided. Factory setting 20. Cannot be more than Risers number <b>Factory setting: 20</b>
57	Trigger timeout	To be used when input source is not stable (B1: f.ex. thermostat switch, or S0: temp. source is not stable) Timer will start to count down the disinfection timeout when B1 is open or. S0 temp. is less that Dis.Set.Temp. Timer is reseted if S0 temp. is higher that Dis.Set.Temp. or B1 input is closed. In case of timeout count down to 0, disinfection will be stopped with timeout fault. <b>Enabled</b> <b>Disabled</b> <b>Factory setting: Disabled</b>
	Set Settings	Click »Set Settings« to confirm changes
	Load settings 1	Load settings from memory 1
	Load settings 2	Load settings from memory 2
	Save settings 1	Save settings into memory 1
	Save settings 2	Save settings into memory 2

#### CORRECTIONS MENU:

No.	Name	Description
58	S0, ... , S36	Sensor correction: S0 ... S36 in range: ±9,9 °C Do not make calibration when sensor cables are shorter than 10 meters. For longer cable then 10 meters, used correction factors from table below.
	Cable Length Calculator	Usefull tool for calculating cable corrections by selecting cable length (m) and cross (mm <sup>2</sup> )
	Save settings	Click »Save Settings« to confirm changes

**10. CCR2+ DASHBOARD**  
**(Web App Screen)**  
 (continuous)

**SCHEDULER MENU:**

No.	Name	Description
59	1. Sunday	Disinfection schedule for selected (Active/non Active) day of the week. To be used in B1+SCH, S0+SCH mode.  <b>Active:</b> Disinfection is permitted in selected time periods <b>non Active:</b> Schedule is not active <b>Start time (hh:mm):</b> set start time period of disinfection <b>Stop time (hh:mm):</b> set finishing time period of disinfection
	2. Monday	
	3. Tuesday	
	4. Wednesday	
	5. Thursday	
	6. Friday	
	7. Saturday	
	Set Settings	Click »Set Settings« to confirm changes
	Load settings 1	Load settings from memory 1
	Load settings 2	Load settings from memory 2
	Save settings 1	Save settings into memory 1
	Save settings 2	Save settings into memory 2

**TESTS MENU:**

No.	Name	Description
60	O1...O4	<b>Open:</b> Selected output contact is open
		<b>Close:</b> Selected output is closed to common (C) <b>Auto</b> <b>Factory setting:</b> Auto
61	V1, ..., V36	<b>Open:</b> selected valve is closed
		<b>Close:</b> selected valve is open, shortcuted to common (C) <b>Auto OnOff:</b> selected valve works in On/off mode <b>AutoPWM:</b> selected valve works in PWM mode <b>Factory setting:</b> AutoPWM
	Save settings	Click »Save Settings« to confirm changes
	Set all as Open	All Open
	Set all as Close	All Close
	Set all as Auto OnOff	All Auto On/Off
	Set all as AutoPWM	All Auto PWM

**DATA MENU:**

No.	Name	Description
62	Delete all logs	Erasing of log file
63	GO to	By selecting time period, log files will be shown and ready for download (*.CSV)

**NETWORK MENU:**

No.	Name	Description
64	Modbus	<b>Enable</b> – Modbus is switch on <b>Disable</b> – Modbus is switched off
65	Modbus baudrate	Type of data transmission: <b>ModBus 96</b> (9,600) <b>Mod Bus 19</b> (19,000) <b>ModBus 38</b> (38,400) <b>FBus</b> <b>Factory setting: ModBus 96</b>
		<b>None</b> (transmission parity disabled) <b>Even</b> (»Even« type of transmission parity enabled) <b>Odd</b> (»Odd« type of transmission parity enabled) <b>Factory setting: Odd</b>
67	Modbus address	Unit Address for Mobus RTU RS485 <b>Factory setting: 1</b>
68	LAN IP address	The IP address that the router assigned to this device when it joined the network. This number can change if a device is disconnected and rejoins the network <b>Factory setting: 192.168.1.100</b>
69	LAN IP address mask	Identify network address of an IP address <b>Factory setting: 255.255.255.0</b>
70	LAN Gateway address	The gateway address (or default gateway) is a router interface connected to the local network that sends packets out of the local network <b>Factory setting: 192.168.1.1</b>
71	LAN name (min. 2 char., max. 15 char.)	Name of CCR2+ (relevant for network search) Please note that after changing this value, local network dns server need to be refreshed. This process is depend on current network configuration and can take up to few hours. <b>Factory setting: ccrplus</b>
72	LAN DHCP	Dynamic Host Configuration Protocol <b>Disable</b> <b>Enable</b> <b>Factory setting: disabled</b>
73	LAN connected clients	Number of LAN connected clients to CCR2+
74	WIFI name (min. 2 char., max. 15 char.)	Wi-Fi name (can be changed) <b>Factory setting: ccrwifi</b>
75	WIFI pass (min. 8 char., max. 15 char.)	Password name (can be changed) <b>Factory setting: admin1234</b>
76	WIFI connected client	Shows IP and name of Wi-Fi connected device
77	Change Login password:	Password name for access to CCR2+ App <b>Factory setting: admin1234</b>

## CCR2+ Controller

### 10. CCR2+ DASHBOARD (Web App Screen) (continuous)

78	Slave Unit Comm. Status	Shows Slave Unit communication status between CCR2+ Controller <b>0%</b> – no communication <b>100%</b> – communication OK Possible (readable values): 0 – 100%
	Save Settings	Click »Save Settings« to confirm changes

**Note:** In case of changing IP address in CCR+ Controller, changes should also be applied in PC local network settings.

#### FIRMWARE MENU:

Name	Description
Upgrade of firmware	To update CCR2+ with new firmware first download firmware file from Danfoss website. Then follow procedure: Browse file -> Start upgrade!
Reset settings to default	To return all setting to default (except Network settings) click on "Return Defaults"
Reset to defaults passwords	To reset all passwords to defaults (admin1234) click on "Reset Passwords«.
Reset network settings	Reset all network settings to defaults

**NOTE:** When uploading firmware, do not interrupt the web browser by closing the window, clicking a link, or loading a new page. No not power-off CCR2+. It could corrupt the firmware.

When the upload is complete, CCR+ restarts. The upgrade process typically takes several minutes.

#### LOGIN MENU – push user to change password

Name	Description
Login	Access with login password enable changes in all setting
Skip login	Access without password allows only data readings. Changes of settings values can not be done.

## 11. Service/trouble shooting

Reset Wi-Fi password	Available via long press on reset button (located on LAN port) for at least 5 seconds. Wi-Fi password is reset to "admin00x" where x is the number of BT (blue) LED blinks.
Reset the setting only	Go to firmware menu and click on "Return Defaults"
Reset password only (but not change other parameters)	Go to firmware menu and click on "Reset passwords"
Recovery (device can be recover back to factory firmware)	<p>Via long press on reset button, power down and with access code "369" (code for recovery to default firmware). To perform a recovery, you need to make these steps:</p> <ol style="list-style-type: none"> <li>1. turn off power supply</li> <li>2. press hardware button</li> <li>3. turn on power supply, power led will be ON</li> <li>4. hold button for more than 5 sec until ALL 3 leds turned ON</li> <li>5. when all 3 leds is turned immediately release the button</li> </ol> <p>From this moment you need to enter 3 digits code In this mode there are two hardware button function:</p> <ul style="list-style-type: none"> <li>- short press increase code number,</li> <li>- long press switch to next code digit</li> </ul> <p>Currently code number is signalled by lighting of led diode: blue led = 1 digit, white led = 2 digit, orange led = 3 digit</p> <p>Example to enter code 123:</p> <ul style="list-style-type: none"> <li>- first led diode (blue) is turned ON, then make a short button press 1 time, blue led should blink once</li> <li>- make a long press until white led is turned on</li> <li>- using short button press 2 times, white led should blinks 2 times</li> <li>- make a long press until orange led is turned on</li> <li>- using short button press 3 times, orange led should blinks 3 times</li> <li>- if code is entered properly than recovery has started.</li> </ul> <p><b>DO NOT TURN OFF POWER SUPPLY!</b></p>

## 12. Modbus settings

**\*Note:** Possible values of disinfection status are:

- 0 - OK
- 2 - disinfection temp too low
- 4 - disinfection in progress
- 8 - disinfection failed
- 16 (0x10 hex) - sensor fault L (shorted to gnd)
- 64 (0x40 hex) - sensor fault H (sensor not connected etc...)

Supported functions:

1. Read holding registers (0x03)
2. Write single register (0x06)
3. Write multiple registers (0x16)

1. Read holding register start addresses:

**from 0 to 279:**

- 0** – Valve output riser  
(1=output closed - valve is open, active in disinfection;  
0=output open, valve is closed)
- 1** – Valve output pwm riser  
(valve open in percentage: 0% .. 100%, unsigned decimal)
- 2** – Temperature value  
(temperature in °C with one decimal place precision,  
unsigned decimal --> example: 529 = 52.9°C)

**3** – Is in disinfection group

(1=valve is in disinfection group of valves, which is in active disinfection state, 0=valve is not in active disinfection group of valves)

**4** – Disinfection progress  
(total disinfection progress in %)

**5** – Disinfection time to end  
(remaining time to end in sec.)

**6** – Disinfection status\*

**Example: To get riser 6 temperature**

Formula: (6(Riser) - 1) × 7 + 2 (Temp Value) = 37

**CCR2+ Controller**

from 252 to 279:	
252	Scheduler open/closed
253	S0 temperature
254	B1 open/closed
255	B2 open/closed
256	B3 open/closed
257	Trigger timeout
258	Memory days left
259	RTC year
260	RTC month
261	RTC day
262	RTC hour
263	RTC minute
264	Disinfection enabled/disabled
265	Disinfection set temperature
266	Disinfection time
267	Min. div. Adv
268	Divide time
269	Circulation set temperature
270	Output 1 value
271	Output 2 value
272	Disinfection status
273	Total disinfection advance
274	Disinfection timeout
275	Divide advance
276	Divide timeout
277	Risers in group
278	Output 3 value
279	Output 4 value
from 300 to 303:	
300	Disinfection flag (enabled/disabled)
301	Disinfection temperature
302	Disinfection time
303	Circulation temperature
from 400 to 421 :	
400	Divide group (enabled/disabled)
401	Divide time
402	Min. advance
403	Riser number
404	CCR system
405	Integration time
406	Proportional factor
407	Req. Temperature
408	Dif temp 1
409	Dif temp 2
410	Alarm delay

411	Alert realy type
412	Archive frequency
413	Dis source
414	Date format
415	CCR is
416	RTC hour
417	RTC minute
418	RTC year
419	RTC month
420	RTC day
421	Start riser number
from 600 to 634 :	
600	Start hour Sunday
601	Start minute Sunday
602	Stop hour Sunday
603	Stop minute Sunday
604	Active Sunday
605	Start hour Monday
606	Start minute Monday
607	Stop hour Monday
608	Stop minute Monday
609	Active Monday
610	Start hour Tuesday
611	Start minute Tuesday
612	Stop hour Tuesday
613	Stop minute Tuesday
614	Active Tuesday
615	Start hour Wednesday
616	Start minute Wednesday
617	Stop hour Wednesday
618	Stop minute Wednesday
619	Active Wednesday
620	Start hour Thursday
621	Start minute Thursday
622	Stop hour Thursday
623	Stop minute Thursday
624	Active Thursday
625	Start hour Friday
626	Start minute Friday
627	Stop hour Friday
628	Stop minute Friday
629	Active Friday
630	Start hour Saturday
631	Start minute Saturday
632	Stop hour Saturday
633	Stop minute Saturday
634	Active Saturday

2. Write single register – data can be written into start addresses:
- from 300 to 303
  - from 400 to 421
  - from 600 to 620

3. Write multiple register – data can be written into start addresses:
- from 300 to 303
  - from 400 to 421
  - from 600 to 620

**ІМПОРТЕР:**

ТОВ з іі "Данфосс ТОВ" 04080, Київ 80, п/с 168, Україна

**Danfoss A/S**

Climate Solutions • danfoss.com • +45 7488 2222

Any information, including, but not limited to information on selection of product, its application or use, product design, weight, dimensions, capacity or any other technical data in product manuals, catalogues descriptions, advertisements, etc. and whether made available in writing, orally, electronically, online or via download, shall be considered informative, and is only binding if and to the extent, explicit reference is made in a quotation or order confirmation. Danfoss cannot accept any responsibility for possible errors in catalogues, brochures, videos and other material. Danfoss reserves the right to alter its products without notice. This also applies to products ordered but not delivered provided that such alterations can be made without changes to form, fit or function of the product.

All trademarks in this material are property of Danfoss A/S or Danfoss group companies. Danfoss and the Danfoss logo are trademarks of Danfoss A/S. All rights reserved.