

ENGINEERING
TOMORROW

Danfoss

Application guidelines

Danfoss scroll compressors **PSH019 to PSH039**

50 - 60 Hz - R410A



ЮГОВ - Проект
інженерно-виробниче підприємство

Офіційний дистриб'ютор
Danfoss в Україні





ugov.ua

<http://cc.danfoss.com>

GENERAL INFORMATION	4	Manage operating envelope	22
		Requirement	22
		High and low pressure protection.....	23
		Discharge gas temperature (DGT) protection	23
		System evaluation	24
		Test, criteria and solutions.....	24
PRODUCT INFORMATION	5	Manage superheat.....	25
Features.....	5	Requirement	25
Overview	5	System evaluation	25
Liquid injection	6	Test, criteria and solutions.....	25
Compressor model designation	7	Manage off cycle migration	27
Nomenclature.....	7	Requirement	27
		System evaluation	27
Technical specifications	8	Provide power supply and electrical protection	28
50-60Hz data	8	Wiring information.....	28
		Soft starts.....	29
Dimensions	9	Control logic.....	30
Single compressors.....	9	Safety control logic requirements.....	30
Connection Details	10	Cycle rate limit requirements	30
Tandem assemblies	11	Oil management logic recommendations	30
		Defrost logic recommendations / Reversible systems.....	30
Electrical data, connections and wiring	12	Pump-down logic recommendations.....	31
Motor voltage	12	Reduce moisture in the system	32
Wiring Connections	12	Requirements.....	32
IP Rating.....	13	Solutions.....	32
Terminal box temperature	13		
Three phase electrical characteristics	14	INTEGRATION INTO SYSTEM	33
LRA (Locked Rotor Amp).....	14	Assembly line procedure	33
MCC (Maximum Continuous Current).....	14	Compressor storage	33
MOC (Maximum Operating Current).....	14	Compressor holding charge.....	33
Motor protection	15	Handling	33
		Piping assembly	34
Approvals and certificates	16	System pressure test and leak detection	34
Approvals and certificates.....	16	Vacuum evacuation and moisture removal	35
Pressure equipment directive 2014/68/EU	16	Refrigerant charging	35
Low voltage directive 2014/35/EU.....	16	Dielectric strength and insulation resistance tests	35
Machines directive 2006/42/EC.....	16		
Internal free volume	16	Commissioning	36
		Preliminary check	36
		Initial start-up	36
		System monitoring	36
SYSTEM DESIGN	17	ORDERING INFORMATION	39
Design piping.....	17	Dismantal and disposal	37
General requirements	17	Ordering information and packaging.....	38
Tandem Configuration.....	18	Accessories.....	40
Design compressor mounting	19		
General requirements	19		
Single requirements	19		
Tandem Kits	19		
Manage oil in the circuit.....	20		
Requirement	20		
System evaluation	20		
Test, criteria and solutions.....	20		
Manage sound and vibration	21		
Compressor sound radiation.....	21		
Mechanical vibrations.....	21		
Gas pulsation	21		

Danfoss PSH019 to 039 compressors are designed and manufactured according to the state of the art and to valid European and US regulations. Particular emphasis has been placed on safety and reliability. Related instructions are highlighted with the following icons:

 This icon indicates instructions to avoid safety risk.

 This icon indicates instructions to avoid reliability risk.

The purpose of this guideline is to help customers qualify compressors in the unit. You are strongly advise to follow these instructions. For any deviation from the guidelines, please contact Danfoss Technical Support. In any case, Danfoss accepts no liability as a result of the improper integration of the compressor into the unit by the system manufacturer.

Features

Overview

Danfoss PSH019 to 039 compressor is optimized for heat pump application. Moreover, it benefits from an improved design to achieve the highest efficiency and increased life time.

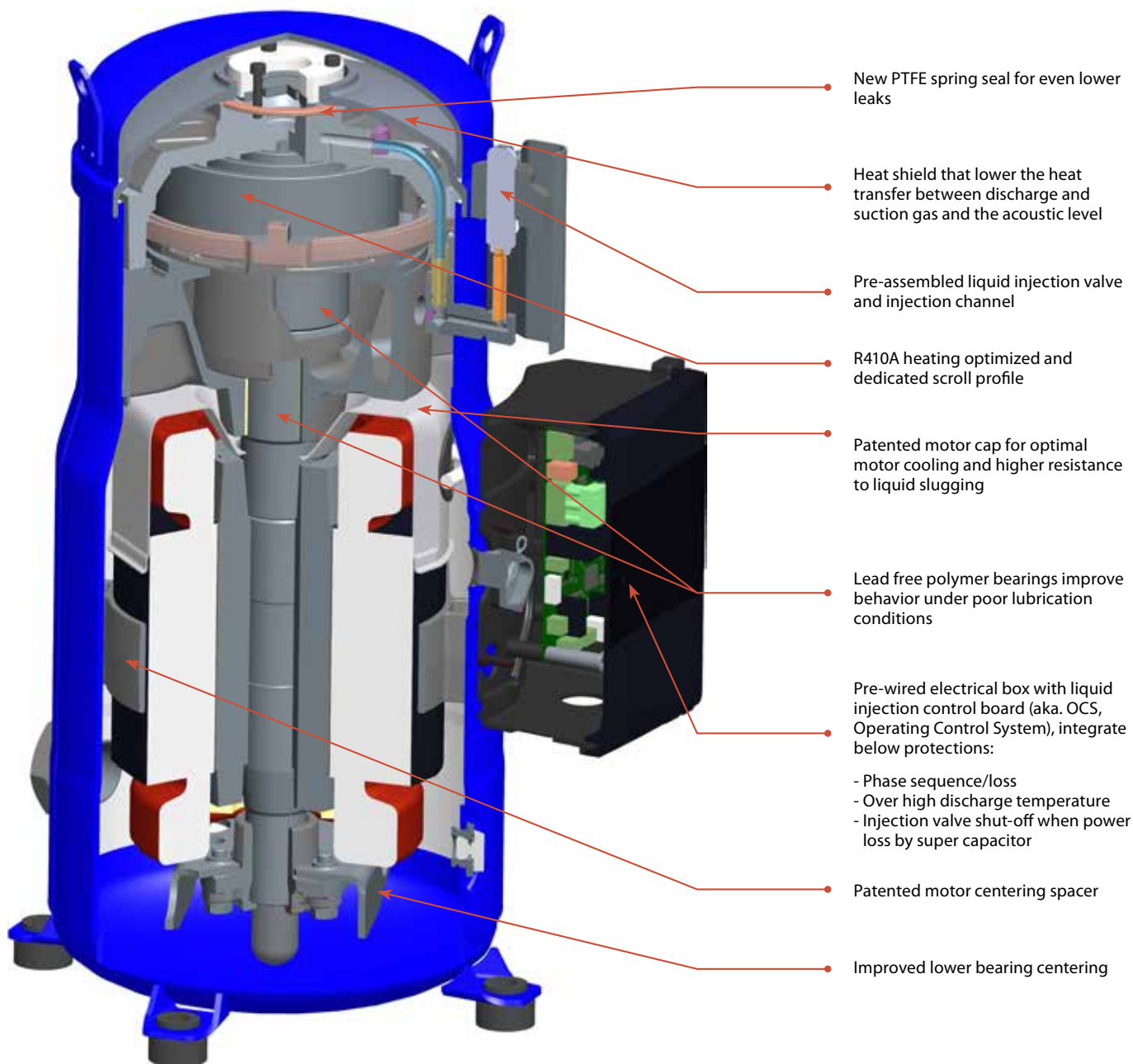

GENERAL INFORMATION

PRODUCT INFORMATION

SYSTEM DESIGN

INTEGRATION INTO SYSTEM

ORDERING INFORMATION

Liquid injection

Danfoss PSH019 to 039 requires liquid injection to maintain sufficiently low discharge gas temperature in the operating envelope. The PSH019 to 039 compressors are provided with a liquid injection connection.

The compressor's liquid injection port should be connected to the system main liquid line after condenser & filter drier. The liquid phase refrigerant is directly injected into the compressor scroll set. Liquid refrigerant vaporize in the scroll and absorb the heat, result in cooling down the compressor's discharge temperature.

A LIV (Liquid Injection Valve) is pre-installed on the PSH019 to 039 compressor to control the liquid injection mass flow, keep the constant compressor discharge gas temperature. The LIV's liquid injection regulation is based on the discharge gas temperature measured via PT1000 temperature sensor located on discharge line. Considering the distance between PT1000 sensor and scroll set, the liquid injection is activated for when discharge temperature exceed 121°C (250°F) at the measurement point.

A Danfoss PT1000 temperature sensor is supplied with PSH compressor in the accessory bag. Customer need attach this sensor on the surface of discharge pipe with 40mm (1.6inch) away from the compressor discharge port, the sensor should be fixed by a metallic collar/clip tube, have good thermal contact by adding thermal paste and be insulated from ambient disturbance by thermal wrap.

PSH019 to 039 compressor's OCS is equipped with super capacitor. In case of suddenly loss the power supply, super capacitor can use its stored energy to shut-off the LIV. This feature could secure compressor without having liquid migration via LIV, mitigate the compressor failure risk at next time start-up. Thanks to this feature, liquid injection line solenoid valve is not mandatory.

A minimum 4K (7.2°F) subcooling is necessary to ensure correct liquid injection.

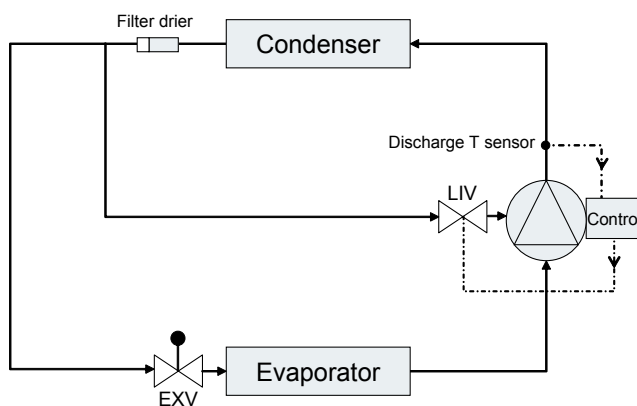
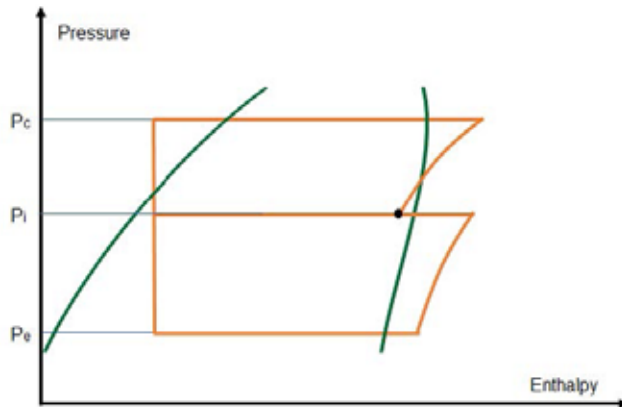

Compressor model designation

Danfoss PSH019 to 039 scroll compressors for R410A are available as single and manifolding compressors. The example below presents the compressor nomenclature which equals to the

technical reference as shown on the compressor nameplate. Code numbers for ordering are listed in section "Ordering information".

Nomenclature

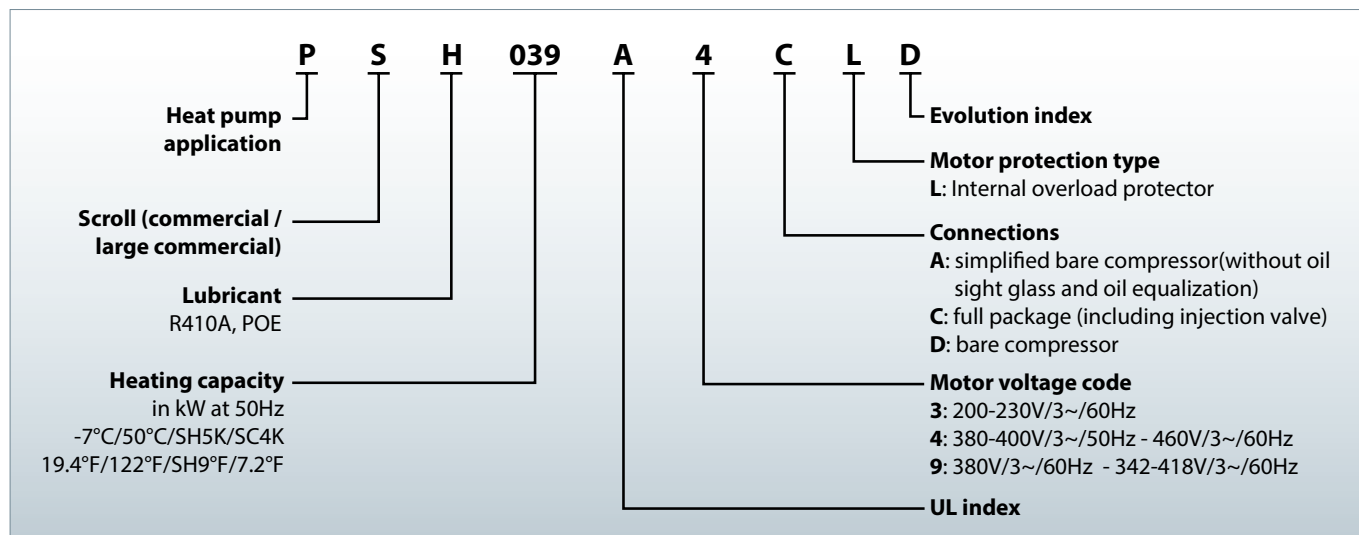

GENERAL INFORMATION

PRODUCT INFORMATION

SYSTEM DESIGN

INTEGRATION INTO SYSTEM

ORDERING INFORMATION

Technical specifications

50-60 Hz data

Model	Nominal Heating capacity		Power Input	COP	Control board & injection valve power consumption	Swept volume		Displacement ^①		Oil charge		Net weight ^②		
	W	Btu/h	kW	W/W	W	cm ³ /rev	cu.in/rev	m ³ /h	cu.ft/h	dm ³	oz	kg	lbs	
50Hz	PSH019	19600	66938	6.62	2.96	3.9	88.40	5.39	15.40	544	3.0	101	58.5	129
	PSH023	23000	78549	7.47	3.07	3.9	103.50	6.32	18.00	636	3.3	112	64.5	142
	PSH026	26000	88795	8.65	3.00	3.9	116.90	7.13	20.30	717	3.3	112	64.5	142
	PSH030	30000	102455	9.60	3.13	3.9	133.00	8.12	23.12	816	3.3	112	67.5	149
	PSH034	34200	116799	10.95	3.12	3.9	151.17	9.22	26.40	932	3.3	112	69.5	153
PSH039	38900	132851	12.19	3.19	3.9	170.30	10.39	29.60	1045	3.6	122	72.0	159	
60Hz	PSH019	23600	80598	7.97	2.96	3.9	88.40	5.39	18.60	657	3.0	101	58.5	129
	PSH023	28000	95625	8.84	3.17	3.9	103.50	6.32	21.80	770	3.3	112	64.5	142
	PSH026	31400	107237	10.19	3.08	3.9	116.90	7.13	24.60	869	3.3	112	64.5	142
	PSH030	35700	121922	11.35	3.15	3.9	133.00	8.12	27.90	985	3.3	112	67.5	149
	PSH034	40500	138315	12.72	3.18	3.9	151.17	9.22	31.90	1127	3.3	112	69.5	153
	PSH039	46500	158806	14.49	3.21	3.9	170.30	10.39	35.80	1264	3.6	122	72.0	159

Evaporating temperature: -7°C (19.4°F)

Condensing temperature: 50°C (122°F)

Superheat: 5K (9°F)

Subcooling: 4K (7.2°F)

Refrigerant: R410A

① Displacement at nominal speed: 2900rpm at 50Hz. 3500rpm at 60Hz

② Net weight with oil charge

Dimensions

Single compressors

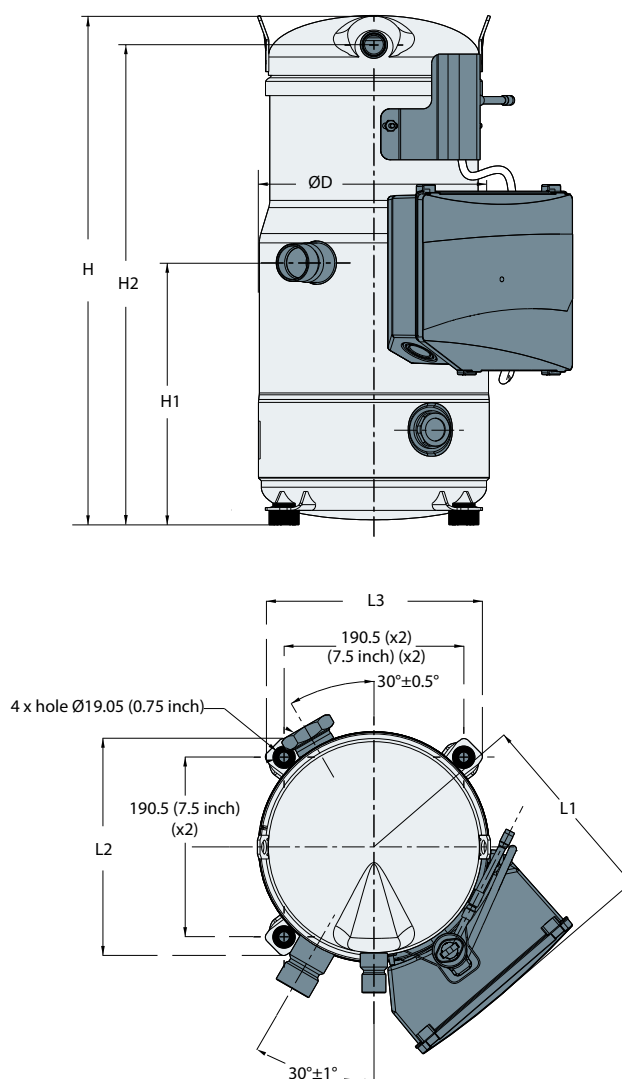

Compressor model	D		H		H1		H2		L1		L2		L3		Outline drawing number
	mm	inch	mm	inch	mm	inch	mm	inch	mm	inch	mm	inch	mm	inch	
PSH019	243	9.57	485	19.09	235	9.25	451	17.76	206	8.11	230	9.06	230	9.06	8560052
PSH023-023-030-034	243	9.57	542	21.34	278	10.94	509	20.04	206	8.11	230	9.06	230	9.06	8560053
PSH039	243	9.57	558	21.97	299	11.77	524	20.63	206	8.11	230	9.06	230	9.06	8560054

Dimensions

Connection Details

		PSH019	PSH023-026-030-034-039
Suction connection		Brazed 1"1/8	Brazed 1"3/8
Discharge connection		Brazed 7/8"	Brazed 7/8"
Liquid injection connection		5/16" ODF	
Oil sight glass		Threaded (1"1/8 - 18 UNEF)	
Oil equalization connection		Rotolock 1"3/4	
Low pressure gauge port (Schrader)		Male 1/4" Flare incorporating a Schrader valve	

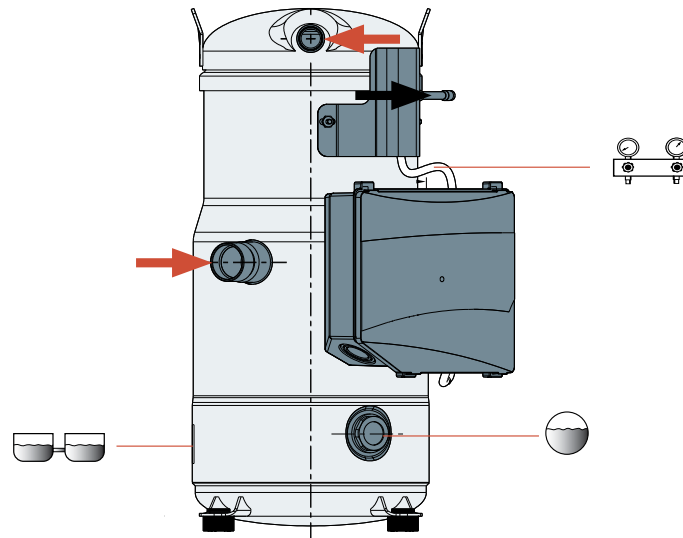

GENERAL INFORMATION

PRODUCT INFORMATION

SYSTEM DESIGN

INTEGRATION INTO SYSTEM

ORDERING INFORMATION

Dimensions

Tandem assemblies

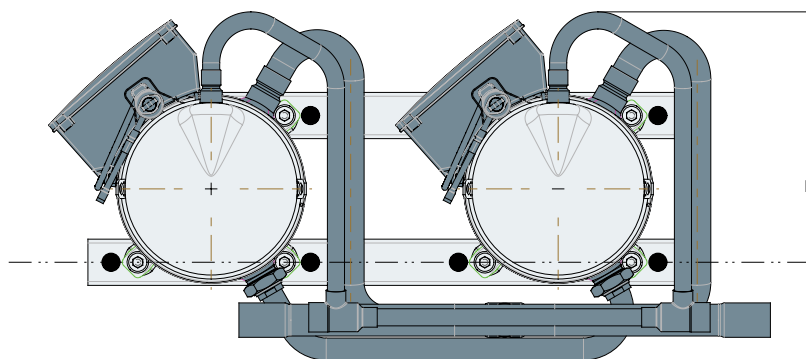
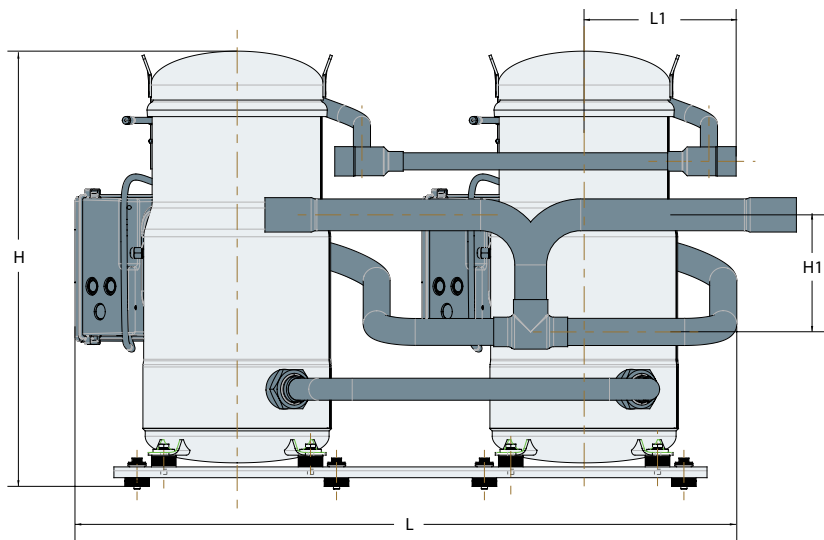

Tandem model	Composition	L		D		H		L1		H1		Outline drawing number
		mm	inch	mm	inch	mm	inch	mm	inch	mm	inch	
PSH038	2×PSH019	937	36.89	452	17.80	507	19.96	240	9.45	152	5.98	5216818
PSH046-052-060-068	2×PSH023-026-030-034	937	36.89	452	17.80	564	22.20	240	9.45	152	5.98	5216818
PSH078	2×PSH039	937	36.89	452	17.80	580	22.83	240	9.45	152	5.98	5216818

GENERAL INFORMATION

PRODUCT INFORMATION

SYSTEM DESIGN

INTEGRATION INTO SYSTEM

ORDERING INFORMATION

Electrical data, connections and wiring

Motor voltage

Danfoss PSH019 to 039 compressors are available in three different motor voltages as listed below;

Motor voltage code		Code 3	Code 4	Code 9
50Hz	Nominal voltage	-	380-400V - 3ph	-
	Voltage range	-	342-440V	-
60Hz	Nominal voltage	200-230V - 3ph	460V - 3ph	380V - 3ph
	Voltage range	180-253V	414-506V	342-418V

The maximum allowable voltage imbalance is 2%. Voltage imbalance causes high amperage over one or several phases, which in turn leads to

overheating and possible motor damage. Voltage imbalance is given by the formula:

$$\% \text{ voltage imbalance} = \frac{(|V_{avg} - V_{1-2}| + |V_{avg} - V_{1-3}| + |V_{avg} - V_{2-3}|)}{2 \times V_{avg}} \times 100$$

V_{avg} = Mean voltage of phases 1, 2, 3
 V_{1-2} = Voltage between phases 1 & 2

V_{1-3} = Voltage between phases 1 & 3
 V_{2-3} = Voltage between phases 2 & 3

Wiring Connections

Electrical supply is connected to the compressor terminals by \varnothing 4.8mm (3/16") screws. The maximum tightening torque is 3Nm. Use a 1/4" ring terminal on the power leads. The compressor must be connected to earth with the 5mm (0.2inch) earth terminal screw.

control of liquid injection valve according to feedback of discharge temperature sensor. The discharge gas temperature cable must be plugged to the discharge temperature sensor installed on discharge tube by customer.

The control board comes pre-installed within the terminal box of full package compressor. The control board comes with pre-wired liquid injection valve connection, is used to provide

In electrical box, three wires are pre-installed between terminals and control board to monitor the phase sequence and phase loss. This could avoid compressor running at abnormal electrical supply and protect the compressor.

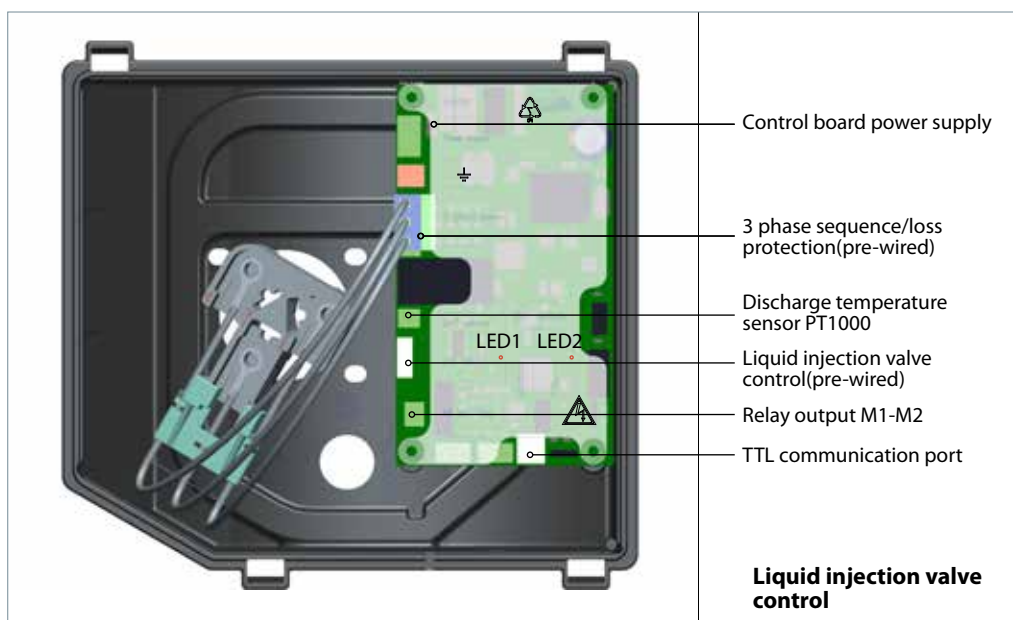

Liquid injection valve control

The control board must be connected to:

- a power supply of the appropriate voltage (230VAC) with a 2 poles 7.62mm (0.3inch) pitch terminal block (an independent power supply is recommended).
- a 1/4" fasten earth connection for 230V supply models.

⚠ Plug and unplug connector on board with electricity is forbidden. Never touch board with electricity by hand or tool. Cable connected to control board can not be short circuit or connect to high voltage.

Electrical data, connections and wiring

Two LED indicators are located on control board as picture showed above.

LED1 is the control board power supply status indicator. When the power supply is ON, the LED1 presents GREEN color. LED2 is the protection status indicator. When there is no alarm, the LED2 presents GREEN color. When there is a alarm, the LED2 presents YELLOW/RED color blinking code. More detail blinking code information refer to related section.

IP Rating

The compressor terminal box according to IEC529 is IP54 for all models when correctly sized IP54 rated cable glands are used.

First numeral, level of protection against contact and foreign object
5- Dust protected

Second numeral, level of protection against water
4- Protection against water splashing

Terminal box temperature

 The temperature inside the terminal box may not exceed 70°C (158°F). Consequently, if the compressor is installed in an enclosure, precautions must be taken to avoid that the temperature around the compressor and in the terminal box would rise too much. The installation of ventilation on the enclosure panels

may be necessary. If not, the control board may not operate properly. Any compressor damaged related to this will not be covered by Danfoss warranty. In the same manner, cables must be selected in a way to insure that terminal box temperature does not exceed 70°C (158°F).

Three phase electrical characteristics

Compressor models		LRA	MCC	MOC	Winding resistance
		A	A	A	Ω
Motor code 3	PSH019	203	43	38	0.39
	PSH023	267	51	50	0.27
	PSH026	267	61	53	0.27
	PSH030	304	64	56	0.24
	PSH034	315	69	64	0.22
	PSH039	351	75	71	0.22
Motor code 4	PSH019	98	20	19	1.47
	PSH023	142	23	22	1.05
	PSH026	142	29	24	1.05
	PSH030	147	32	28	0.92
	PSH034	158	33	31	0.83
	PSH039	197	38.6	36	0.83
Motor code 9	PSH019	124	26	23	1.05
	PSH023	160	33	26	0.72
	PSH026	160	35	29	0.72
	PSH030	168	37	33	0.62
	PSH034	177	41	37	0.57
	PSH039	239	51	44	0.57

LRA (Locked Rotor Amp) Locked Rotor Amp value is the highest average current as measured on mechanically blocked compressor tested under nominal voltage. The LRA value can be used as rough estimation for the starting current. However in most cases, the real starting current will be lower. A soft starter can be applied to reduce starting current (See section "soft start").

MCC (Maximum Continuous Current) The MCC is the current at which the motor protection trips under maximum load and low voltage conditions. This MCC value is the maximum at which the compressor can be operated in transient conditions and out of the application envelope.

MOC (Maximum Operating Current) The MOC is the current when the compressors operates at maximum load conditions and 10% below nominal voltage. MOC can be used to select cables and contactors. In normal operation, the compressor current consumption is always less than the MOC value.

Electrical data, connections and wiring

Winding resistance

Winding resistance is the resistance between phases at 25°C (77°F) (resistance value +/- 7%).

Winding resistance is generally low and it requires adapted tools for precise measurement. Use a digital ohm-meter, a "4 wires" method and measure under stabilised ambient temperature. Winding resistance varies strongly with winding temperature; if the compressor is stabilised at a different value than 25°C (77°F), the measured resistance must be corrected with following formula:

$$R_{amb} = R_{25^{\circ}\text{C}(77^{\circ}\text{F})} \frac{a + t_{amb}}{a + t_{25^{\circ}\text{C}(77^{\circ}\text{F})}}$$

$t_{25^{\circ}\text{C}(77^{\circ}\text{F})}$: reference temperature = 25°C (77°F)
 t_{amb} : temperature during measurement °C(°F)
 $R_{25^{\circ}\text{C}(77^{\circ}\text{F})}$: winding resistance at 25°C (77°F)
 R_{amb} : winding resistance at t_{amb}
 Coefficient $a = 234.5$

Motor protection

The compressors models PSH019 to 039 have been provided with an internal overload protection to prevent against excessive current and temperature caused by overloading, low refrigerant flow or phase loss. The cutout current is the MCC value listed before.

The protector is located in the star point of the motor and, should it be activated, will cut out all three phases. It will be reset automatically. While

not compulsory, an additional external overload is still advisable for either alarm or manual reset.

Then it must be set below MCC value:

- When the motor temperature is too high, then the internal protector will trip.
- When the current is too high the external overload protection will trip before the internal protection therefore offering possibility of manual reset.

Phase sequence/loss protection

Use a phase meter to establish the phase orders and connect line phases L1, L2 and L3 to terminals T1, T2 and T3, respectively. The compressor will only operate properly in a single direction, and the motor is wound so that if the connections are correct, the rotation will also be correct.

PSH019 to 039 control board provides protection against phase reversal and phase loss at start-up. Apply the recommended wiring diagram from the section "Wiring information". The circuit should be thoroughly checked in order to

determine the cause of the phase problem before re-energizing the control circuit.

The phase sequence and phase loss monitoring functions are active during a 5 seconds window 1 second after compressor start-up (power on L1-L2-L3).

R The pre-wired lines between compressor power terminals and control board are NOT allowed to disconnect! Disconnection of those pre-wired lines may loss this protection and cause other function abnormal.

LED2 status display	Blinking sequence	Status
	Continuous on	No alarm
	Yellow 2 times/Red 1 time	ALARM: Phase loss error ACTION: Relay output M1-M2 open, compressor stopped RESET: Power off, power on the OCS board
	Yellow 2 times/Red 2 time	ALARM: Phase sequence error ACTION: Relay output M1-M2 open, compressor stopped RESET: Power off, power on the OCS board

Approvals and certificates

Approvals and certificates

PSH019 to 039 scroll compressors comply with the following approvals and certificates.

Certificates are listed on the product datasheets: <http://www.danfoss.com/odsg>

CE 0062 or CE 0038 or CE0871 (European Directive)		All PSH models
UL (Underwriters Laboratories)		All 60 Hz PSH models
Other approvals / certificates		Contact Danfoss

Pressure equipment directive 2014/68/EU

Products	PSH019 to 039
Refrigerating fluids	Group 2
Category PED	II
Evaluation module	D1
Maximum/Minimum temperature - Ts	-35°C < Ts < 55°C (-31°F < Ts < 131°F)
Maximum allowable pressure (Low side) - Ps	33.3 bar(g) (483psig)
Declaration of conformity	Contact Danfoss

Low voltage directive 2014/35/EU

Products	PSH019 to 039
Declaration of conformity ref. Low voltage Directive 2014/35/EU	Contact Danfoss

Machines directive 2006/42/EC

Products	PSH019 to 039
Manufacturer's declaration of incorporation ref. Machines Directive 2006/42/EC	Contact Danfoss

Internal free volume

Products	Internal free volume without oil	
	litre	cu.inch
PSH019	12.4	757
PSH023-026-030-034	14.3	873
PSH039	14.6	891

General requirements

Proper piping practices should be employed to:

1. Ensure adequate oil return, even under minimum load conditions (refrigerant speed, piping slopes...). For validation tests see section "Manage oil in the circuit".

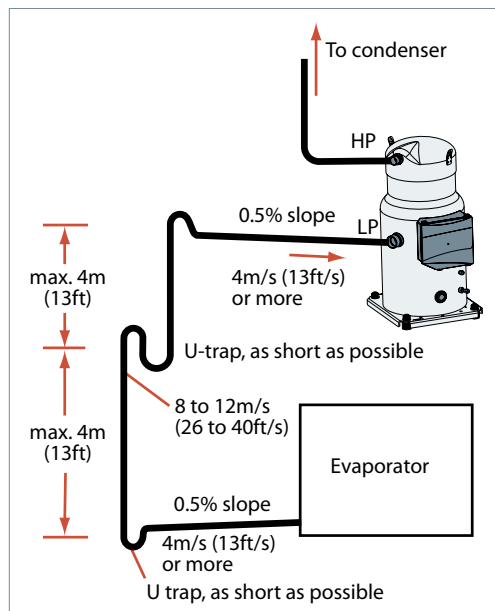

3. Piping should be designed with adequate three-dimensional flexibility to avoid excess vibration. It should not be in contact with the surrounding structure, unless a proper tubing

2. Avoid condensed liquid refrigerant from draining back to the compressor when stopped (discharge piping upper loop). For validation tests see section "Manage off cycle migration".

General recommendations are described in the figures below:

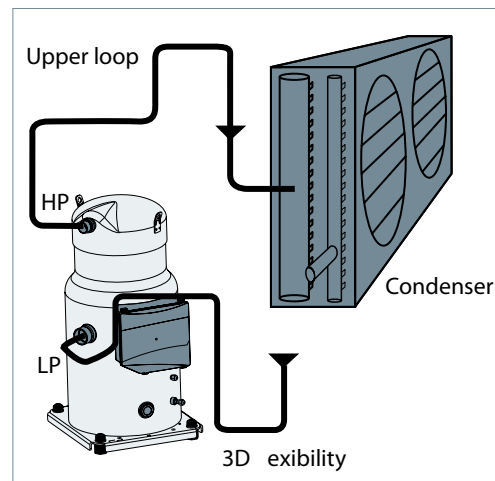

mount has been installed. For more information on noise and vibration, see section on: "Sound and vibration management".

Tandem Configuration

PSH019 to 039 are qualified with even tandem combination use static system to balance the oil level between the compressors.

- Tubings, according to specific outline drawings indicated in the following table.
- Tandem kit.
- Compressors.

By default, PSH tandems are not factory-built. To complete an assembly in the field, you will need:

Tandem configuration	Suction	Discharge	Oil equalization line	Outline drawing number	Tandem kit
PSH019+PSH019	1"3/8	1"3/8	1"1/8	5216818	7777054
PSH023+PSH023	1"5/8	1"3/8	1"1/8	5216818	7777054
PSH026+PSH026	1"5/8	1"3/8	1"1/8	5216818	7777054
PSH030+PSH030	1"5/8	1"3/8	1"1/8	5216818	7777054
PSH034+PSH034	1"5/8	1"3/8	1"1/8	5216818	7777054
PSH039+PSH039	1"5/8	1"3/8	1"1/8	5216818	7777054

Oil Equalization Detail

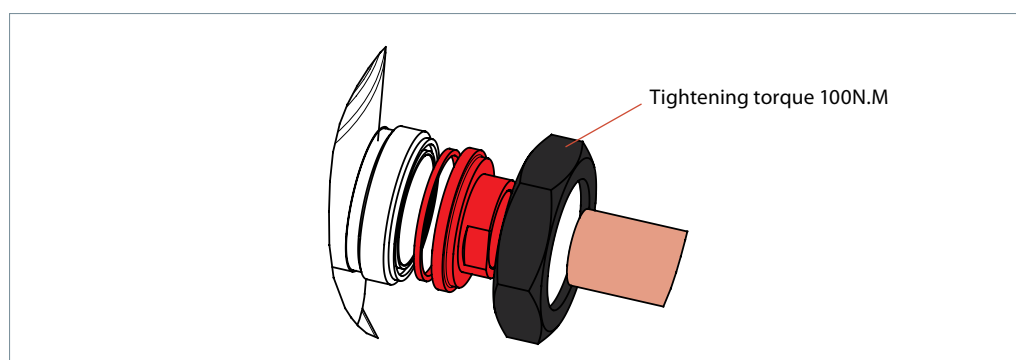
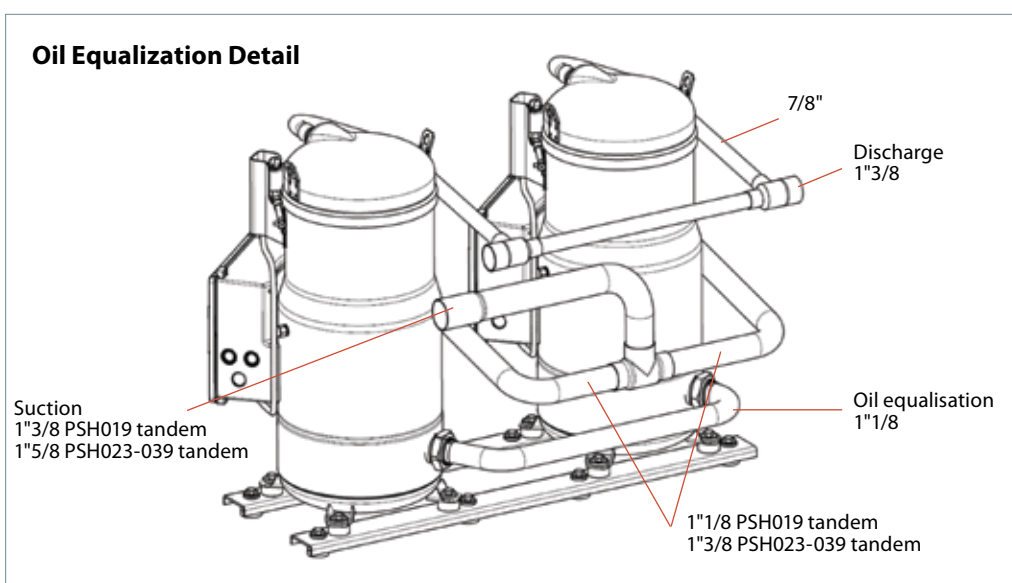

- Supplied with the compressor
- Included in tandem kit
- Not supplied

GENERAL INFORMATION
PRODUCT INFORMATION
SYSTEM DESIGN
INTEGRATION INTO SYSTEM
ORDERING INFORMATION

Design compressor mounting

General requirements

Compressors used in single applications must be mounted with flexible grommets.

the manifold assembly must be mounted with flexible grommets onto the frame.

Compressors used in parallel applications must be mounted with rigid spacers onto rails and

During operation, the maximum inclination from the vertical plane must not exceed 3 degrees.

Single requirements

Compressor PSH019 to 039 are delivered with rubber grommets and steel mounting sleeve used to isolated the compressor from the base frame.

The grommets must be compressed until contact between the flat washer and the steel mounting sleeve is established. The required bolt size for the PSH019 to 039 compressors is HM8-40. This bolt must be tightened to a torque of 15Nm.

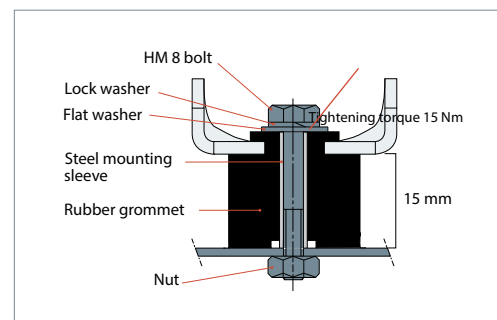

Tandem Kits

The compressors must be mounted with rigid mounting spacers on rails. Rubber grommets and spacers must be installed below rails.

The rigid mounting spacers are included in tandem accessory kits. The rubber grommets are supplied with compressor.

For more details about parallel mounting feet, please see parallel unit outline drawing.

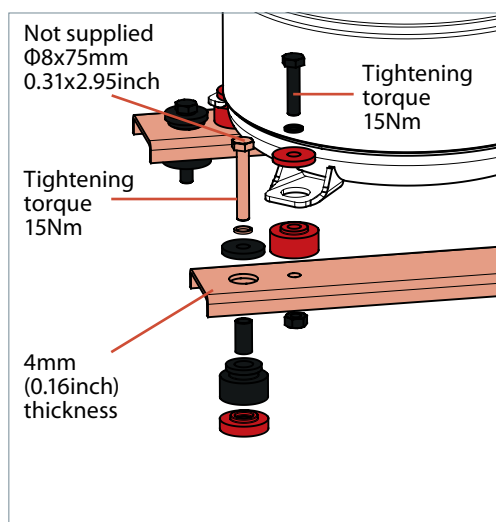

- Supplied with the compressor
- Included in tandem kit
- Not supplied

Manage oil in the circuit

Requirement

R Oil level must be visible or full in the sight glass when the compressor is running and when all compressors of the circuit are stopped.

System evaluation

	Single compressor	Manifold compressors
Non split	Test N°1	Test N°1+2
Split	Test N°1+3	Test N°1+2+3

Test, criteria and solutions

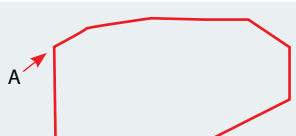
Test N°	Purpose	Test conditions	Pass criteria	Solutions
1	Check proper oil return	 <p>Lowest foreseeable evaporation, and highest foreseeable condensation. Minimum number of compressor running for 6 hours.</p> <p>For reversible system, perform test in both heating and cooling mode.</p>	Oil level must be visible or full in the sight glass when the compressor is running and when all compressors of the circuit are stopped.	<ol style="list-style-type: none"> 1. Top-up with oil, generally 3% of the total system refrigerant charge (in weight). Above 3% look for potential oil trap in the system. 2. Integrate a function in control logic to run all compressors simultaneously in order to boost oil return (for more details see section "Control Logic") 3. Oil separator can be added
2	Check oil balancing	 <p>Lowest foreseeable evaporation, and highest foreseeable condensation. All compressor running for 6 hours.</p> <p>For reversible system, perform test in both heating and cooling mode.</p>	Oil level must be visible or full in the sight glass when the compressors are running and when all compressors of the circuit are stopped	<ol style="list-style-type: none"> 1. Top-up with oil, generally 3% of the total system refrigerant charge (in weight). 2. Check that manifold piping is conform to Danfoss requirements. 3. Integrate a function in control logic to stop manifold periodically in order to balance oil (for more details see section "Control Logic")
3	Oil return in split systems	Since each installation is unique, test 1 and 2 can not fully validate the oil return. Oil level must be checked and adjusted at commissioning.	Oil level must be visible or full in the sight glass when the compressor is running and when all compressors of the circuit are stopped.	<ol style="list-style-type: none"> 1. Pay special attention to "Piping design" 2. Oil separator is strongly recommended, especially in case of part load.

Compressor sound radiation

Typical sounds and vibrations in systems can be broken down into the following three categories:

- Sound radiation (through air)
- Mechanical vibrations (through parts and structure)

- Gas pulsation (through refrigerant)

The following sections focus on the causes and methods of mitigation for each of the above sources.

For sound radiating from the compressors, the emission path is air and the sound waves are travelling directly from the machine in all directions.

Sound levels are as follows:

- For compressors running alone:

Sound power dB(A)	Sound power dB(A)	
	50Hz	60Hz
PSH019	75	77
PSH023	76.5	78.5
PSH026	77.5	79
PSH030	77.5	79
PSH034	79	81
PSH039	78	80

Sound Power and attenuation are given at -7/50°C condition.

Mechanical vibrations

A compressor generates come from vibrations that propagate into the surrounding parts and structure. The vibration level of a PSH019 to 039 compressor alone does not exceed 120µm peak to peak. However, when system structure natural frequencies are close to running frequency, vibrations are amplified due to resonance phenomenon.

requirements (mounting feet, rails etc.). For further information on mounting requirements, please refer to section "Design compressor mounting".

A high vibration level is damageable for piping reliability and generates high sound levels.

2. Ensure that there is no direct contact (without insulation) between vibrating components and structure.

Mitigations methods:

1. To ensure minimum vibrations transmission to the structure, strictly follow Danfoss mounting

3. To avoid resonance phenomenon, pipings and frame must have natural frequencies as far as possible from running frequencies (50 or 60Hz). Solutions to change natural frequencies are to work on structure stiffness and mass (brackets, metal sheet thickness or shape...)

Gas pulsation

PSH019 to 039 have been designed and tested to ensure that gas pulsation is optimized for the most commonly encountered air conditioning pressure ratio. Manifoldded compressors are equivalent to lagged sources of gas pulsation. Therefore, pulse level can vary during time.

Mitigations methods:

If an unacceptable level is identified, a discharge muffler with the appropriate resonant volume and mass can be installed.

Manage operating envelope

Requirement

R The operating envelope for PSH019 to 039 scroll compressor is given in the figure below and guarantees reliable operations of the compressor for steady-state operation. The discharge temperature is controlled by OCS and limited at 131°C (268°F) (at PT1000

measurement location). Steady-state operation envelope is valid for a suction superheat within 5K (9°F) to 30K (54°F) range at nominal voltage. And a subcooling below 4K (7.2°F) is not recommended to ensure proper liquid injection.

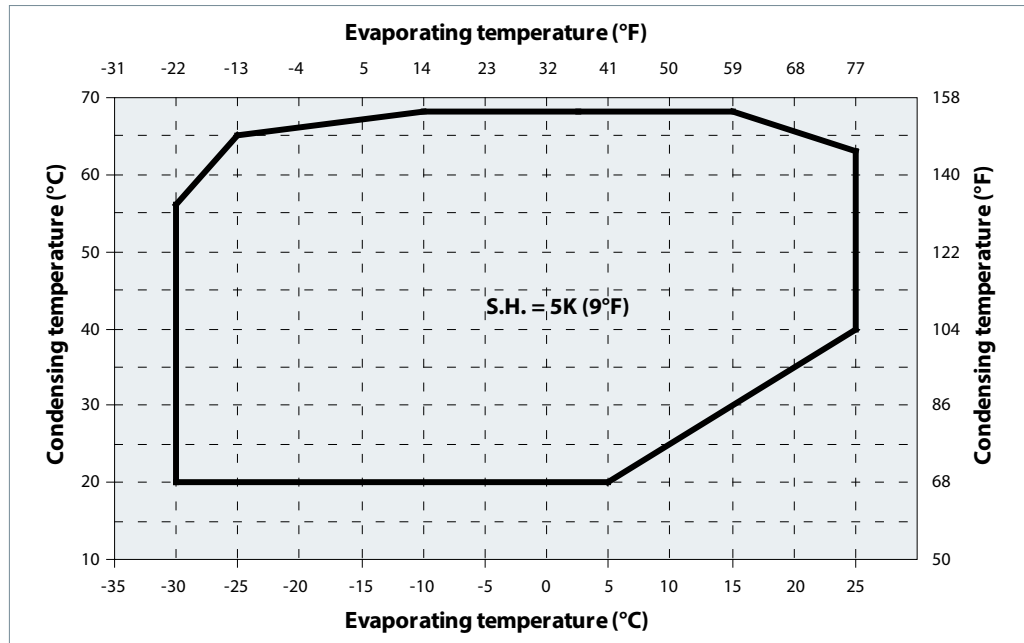

Pressure settings		R410A
Working range high side	bar(g)	13.6-44.4
	psig	197-644
Working range low side	bar(g)	1.7-15.7
	psig	25-228
Maximum high pressure safety switch setting	bar(g)	46.1
	psig	669
Minimum low pressure safety switch setting	bar(g)	1.5
	psig	22
Minimum low pressure pump-down switch setting	bar(g)	1.5 bar below nominal evap. pressure with minimum of 1.7 bar(g)
	psig	22 psi below nominal evap. pressure with minimum of 25psig

Manage operating envelope

High and low pressure protection

 Low-pressure (LP) and high-pressure (HP) safety switches must never be bypassed nor delayed and must stop all the compressors.

LP switch auto restart must be limited to 5 times within 12 hours.

 HP safety switch must be reset manually.

Depending on application operating envelope, you must define HP and LP limits within operating envelope and pressure setting table above.





Discharge gas temperature (DGT) protection

PSH compressor is equipped with DGT sensor PT1000 linked to OCS board. DGT is permanently monitored by OCS board. OCS has a relay function so called M1-M2 connected to unit safety chain.

If the DGT is higher than tripping set point (default is 131°C (268°F)) for more than 1 second, DGT protection is activated, relay output M1-M2 is open. This DGT protection function is automatically reset when the DGT is lower than reset set point (default is 106°C (223°F)) for more than 5 minutes.

If DGT protection occurs more than 5 times within a 1 hour window, relay M1-M2 open and OCS requires manual reset. Manual reset is done by power off, power on the OCS board

If DGT measurement is out of range (-50°C (-58°F) to 180°C (356°F)), or if a fault is detected on sensor, relay M1-M2 open and OCS requires manual reset.

LED2 status display	Blinking sequence	Status
	Continuous on	No alarm
	Yellow 1 time/Red 1 time	ALARM: DGT too high, automatic reset delay on-going ACTION: Relay output M1-M2 open, compressor stopped RESET: Automatic reset after DGT lower than reset set point for more than 5 minutes, no more than 5 times/hour
	Yellow 1 time/Red 2 times	ALARM: DGT too high, more than 5 times/hour ACTION: Relay output M1-M2 open, compressor stopped RESET: Power off, power on the OCS board
	Yellow 1 time/Red 3 times	ALARM: DGT sensor out of PT1000 range ACTION: Relay output M1-M2 open, compressor stopped RESET: Power off, power on the OCS board
	Yellow 1 time/Red 4 times	ALARM: DGT sensor short/open ACTION: Relay output M1-M2 open, compressor stopped RESET: Power off, power on the OCS board

System evaluation

HP and LP must be monitored to respect operating envelope limitations. We consider two types of operating envelope management:

<p>Basic:</p> <ul style="list-style-type: none"> • HP and LP switch • MOP (Max Operating Pressure) ensured by expansion device • Condensing pressure control 	<p>Advanced:</p> <ul style="list-style-type: none"> • HP and LP sensor • Operating envelope limits integrated into control logic
---	--

See "Test, criteria and solutions"

Test, criteria and solutions

Test N°	Purpose	Test condition	Pass criteria	Solutions
1	Ensure compressor operate within envelope	Start test at minimum foreseeable evaporating temperature (minimum ambient temperature...)	Continuous running within envelope	Work on compressor staging, fan staging, water flow etc.
2		Perform a defrost test if reversible unit		

GENERAL INFORMATION

PRODUCT INFORMATION

SYSTEM DESIGN

INTEGRATION INTO SYSTEM

ORDERING INFORMATION

Manage superheat

During normal operation, refrigerant enters the compressor as a superheated vapor. Liquid flood back occurs when a part of the refrigerant entering the compressor is still in liquid state.

Liquid flood back can cause oil dilution and, in extreme situations lead to liquid slugging that can damage the compressor.

Requirement

In steady state conditions the expansion device must ensure a suction superheat within 5K to 30K (9 to 54°F).

System evaluation

Use the table in relation with the application to quickly evaluate the potential tests to perform.

Application	Tests to perform
Non reversible	Liquid flood back test
Reversible	Liquid flood back test Defrost test

Test, criteria and solutions

Test N°	Purpose	Test condition	Pass criteria	Solutions
Liquid flood back test	Steady-state	 <p>Liquid flood back testing must be carried out under expansion valve threshold operating conditions:</p> <ul style="list-style-type: none"> • Lowest foreseeable evaporation, and highest foreseeable condensation. • Minimum number of compressor running. <p>For reversible system, perform test in both heating and cooling mode.</p>	Suction superheat >5K (9°F)	<ol style="list-style-type: none"> 1. Check expansion valve selection and setting. <ul style="list-style-type: none"> • For Thermostatic expansion valve (TXV) check bulb position... • For Electronic expansion valve (EXV) check measurement chain and PID.... 2. Add a suction accumulator*.
	Transient	<p>Tests must be carried out with most unfavorable conditions :</p> <ul style="list-style-type: none"> • fan staging, • compressor staging • ... 	Oil superheat shall not be more than 30 sec below the safe limit defined in the Dilution Chart. (see graph below)	
Defrost test	Check liquid floodback during defrost cycle	Defrost test must be carried out in the most unfavorable conditions (at 0°C (32°F) evaporating temperature).	Oil superheat shall not be more than 30 sec below the safe limit defined in the Dilution Chart. (see graph below)	<ol style="list-style-type: none"> 1. Check defrost logic. In reversible systems, the defrost logic can be worked out to limit liquid floodback effect. (for more details see "Control Logic"). 2. Add a suction accumulator*.

*Suction accumulator offers protection by trapping the liquid refrigerant upstream from the compressor. The accumulator should be sized at least 50 % of the total system charge. Suction accumulator dimensions can impact oil return (gas velocity, oil return hole size...), therefore oil return has to be checked according to section "Manage oil in the circuit".

Manage superheat

GENERAL INFORMATION
PRODUCT INFORMATION
SYSTEM DESIGN
INTEGRATION INTO SYSTEM
ORDERING INFORMATION

Oil temperature sensor must be placed between the oil sight glass and the compressor baseplate. Some thermal paste shall be used to improve the conductivity. The sensor must also be correctly thermally insulated from the ambience.

The Oil superheat is defined as:
 (Oil temperature - Evaporating temperature)

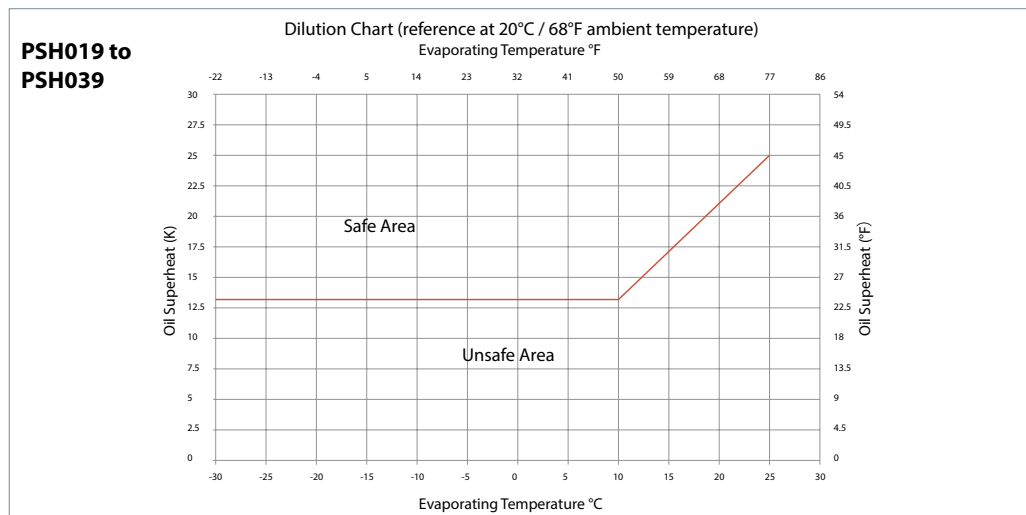
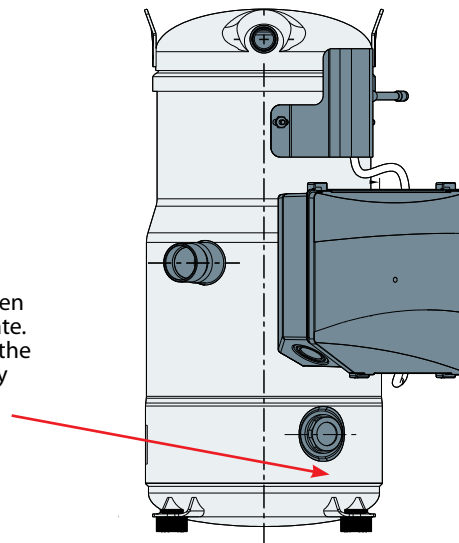

Manage off cycle migration

- R** Off-cycle refrigerant migration happens:
- when the compressor is located at the coldest part of the installation, refrigerant vapor condenses in the compressor.
 - or directly in liquid-phase by gravity or pressure difference. When the compressor restarts,

the refrigerant diluted in the oil, or stored in evaporator, generates poor lubrication conditions, and may reduce bearings life time. In extreme situations, this leads to liquid slugging that can damage the compressor scroll set.

Requirement

- Compressor can tolerate occasional flooded start, but it should remain exceptional situation and unit design must prevent that this situation happen at each start.
- Right after start, liquid refrigerant must not flow massively to compressor.
- The charge limit is a threshold beyond some protective measures must be taken to limit risk of liquid slugging and extreme dilution at start.

System evaluation

Use the table below in relation with the system charge and the application to quickly define necessary safeties to implement.

Application	BELOW charge limit	ABOVE charge limit
All	Ensure tightness between condenser & evaporator when system is OFF • Thermostatic expansion Valve (TXV) , Liquid Line Solenoid Valve LLSV** strongly recommended • Electronic expansion valve (EXV) must close when system stop including in power shut down situation	
Non split	External Non-return Mandatory for unit with water condenser (W/W or reversible A/C Chiller)	• Surface Sump Heater * • External Non-Return Valve
Split	Since each installation is unique, refrigerant charge may vary • Surface Sump Heater * • Liquid Line Solenoid Valve**+ pump-down cycle • External Non-Return Valve	

*Surface Sump heater

The surface sump heaters are designed to protect the compressor against off-cycle migration of refrigerant.

For PSH019 to 039, the surface sump heater is located on the compressor shell.

The heater must be turned on whenever all the compressors are off.

Surface sump heater accessories are available from Danfoss (see section "Accessories").

**Liquid line solenoid valve (LLSV)

A LLSV is used to isolate the liquid charge on the condenser side, thereby preventing against charge transfer to the compressor

Charged limits are defined in the table below:

Model	Refrigerant charge limit in the compressor	
	kg	lbs
PSH019	5.9	13
PSH023-026-030-034-039	7.9	17

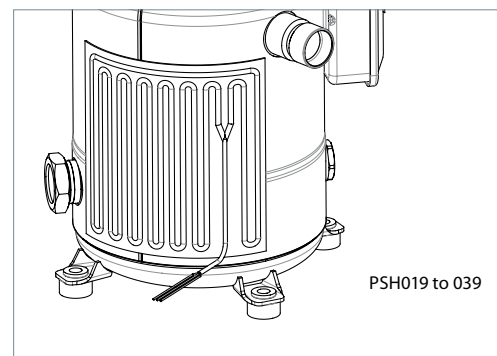

during off-cycles. The quantity of refrigerant on the low-pressure side of the system can be further reduced by using a pump-down cycle in association with the LLSV.

Provide power supply and electrical protection

Wiring information

Requirements:

PSH019 to 039 models are delivered with an integrated phase protection and discharge temperature protection on the liquid injection control board in electrical box.

- HP safety switch and control board output (M1-M2 relay) must be wired in the safety chain. Other safety devices such as LP switch can be either hardware or software managed.

- Provide separate electrical supply for the sump heater so they remain energized even when the machine is out of service (e.g. seasonal shutdown).

- Provide separate electrical supply to liquid injection control board. Normally the control board should be energized together with the unit controller.

The wiring diagrams below are examples for a safe and reliable compressor wiring:

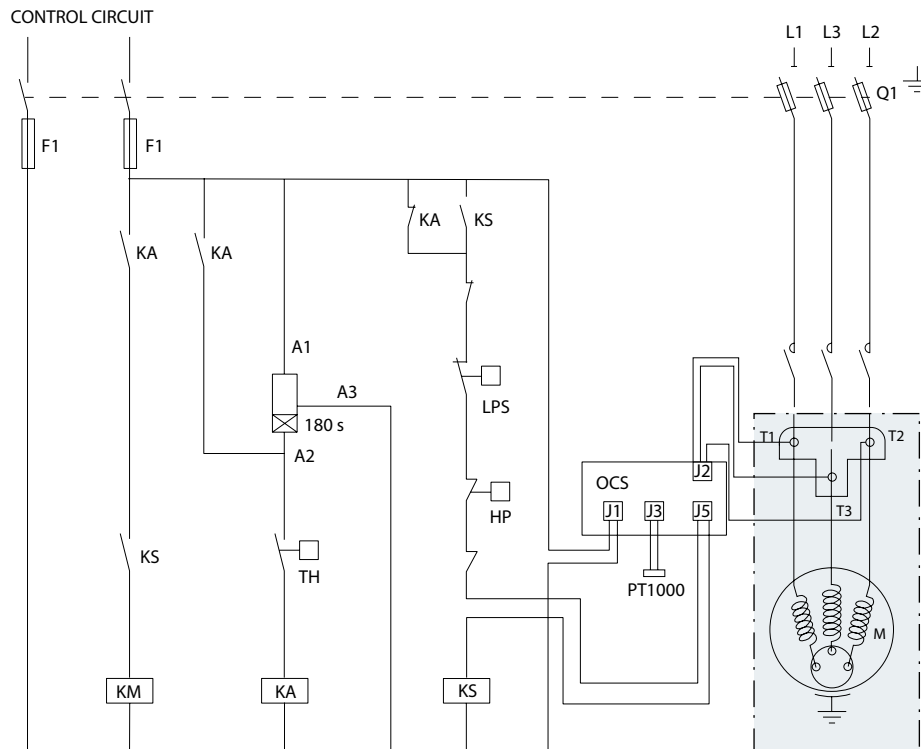

Legend:

Fuses	F1
Compressor contactor	KM
Control relay	KA
Safety lock out relay	KS
Optional short cycle timer (3min)	180 s
High pressure safety switch	HP
Fused disconnect	Q1
Compressor motor	M
Discharge gas temperature	DGT
Safety pressure switch	LPS
Control circuit	CC
Operating Control System	OCS

Provide power supply and electrical protection

Soft starts

R Soft starters are designed to reduce the starting current of 3-phase AC motors. Soft starter must be set so compressor start-up time is always less than 0.5 seconds to ensure proper lubrication of compressor parts.

Ramp-down must be set to minimum to ensure proper discharge valve closing. Danfoss MCI soft-start controller are available as accessories: MCI can reduce the inrush current up to 40%.

Selection table:

Compressor model	Soft start reference Ambient max. 40°C	Soft start reference Ambient max. 55°C
PSH019	MCI15C	MCI15c
PSH023 to 030	MCI25C	MCI25C*
PSH034 to 039	MCI50CM	MCI50CM

* by-pass contactor K1 is required

- MCI15C, MCI25C, MCI50CM replaces the contactor KM . All settings such as initial torque, ramp-up time (less than 0.5 sec) and ramp-down time are preset and do not require any modification.

See wiring diagram:

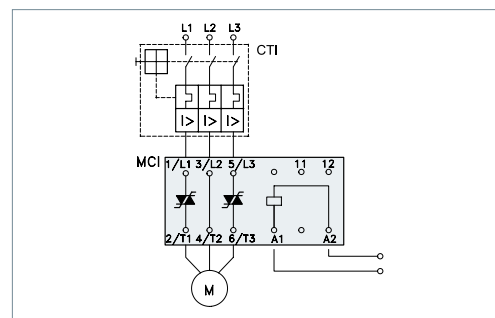

- MCI25C* requires a by-pass contactor K1. This configuration is needed to withstand current or temperature levels. All settings such as initial torque, ramp-up time (less than 0.5 sec) and ramp-down time are preset and do not require any modification.

See wiring diagram:

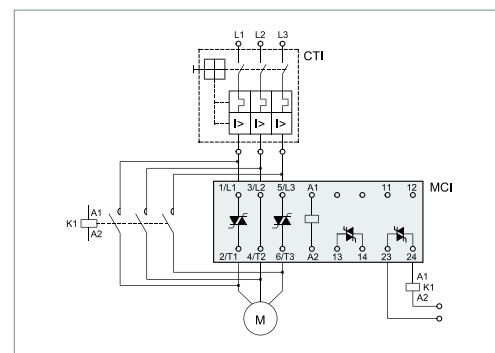

Control logic

Safety control logic requirements

Safeties	Tripping conditions		Re-start conditions	
	Value	Time	Value	Time
HP safety switch	See Pressure settings table from section "Manage operating envelope"	Immediate, no delay. No by-pass	Conditions back to normal. Switch closed again	Manual reset
LP safety switch				Maximum 5 auto reset during a period of 12 hours, then manual reset.
Integrated protection (phase sequence/loss, DGT)				Contact M1-M2 opened

Cycle rate limit requirements

Danfoss requires a minimum compressor running time of 3 minutes to ensure proper oil return and sufficient motor cooling.

Additionally, compressor must not exceed 12 starts per hour.

Oil management logic recommendations

In some cases, oil management can be enhanced by control logic:

- If oil return test failed, a function can be integrated in control logic to run all compressors simultaneously during 2 minutes every hour in order to boost oil return. Time and delay can be fine-tuned by oil return test N°1 in section "Manage oil in the circuit". During oil boost, pay special attention to superheat management to avoid liquid flood back.

- In manifold system, after running long time in full load, oil unbalance may appear. A function can be implemented in control logic to stop all manifold compressors during one minute every two hours in order to balance oil. Time and delay can be fine-tuned by Oil balancing test N°2 in section "Manage oil in the circuit".

Defrost logic recommendations / Reversible systems

In reversible systems, the defrost logic can be worked out to limit liquid flood back effect by:

1. Running full load during defrost to share liquid refrigerant between all compressors.

2. Reducing refrigerant flooding to compressor by transferring liquid refrigerant from one exchanger to the other before reversing valve thanks pressures.

The following defrost logic combines both advantages:

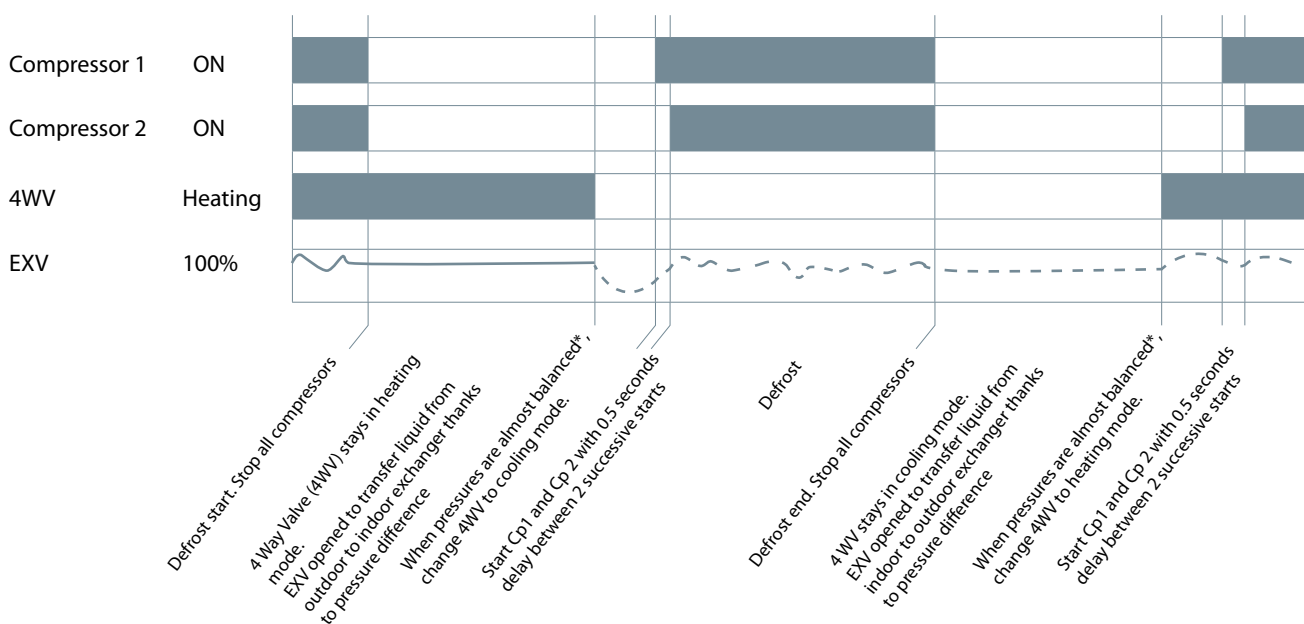

* EXV Opening degree and time have to be set to keep a minimum pressure for 4 way valve moving.

In any case, defrost logics must respect requirements and tests described in sections "Manage superheat" and "Manage operating envelope".

In reversible systems, to ensure compressor reliability, the 4-way valve must not reverse when the compressor is stopped due to heating or cooling demand (stop on thermostat).



Control logic

Pump-down logic recommendations

Pump down is initiated prior to shutting down the last compressor on the circuit by de-energizing a liquid line solenoid valve or closing electronic expansion valve. When suction pressure reached the cut-out pressure, compressor is stopped, and liquid solenoid valve or electronic expansion valve remains closed. Two types of pump-down exist:

- One shot pump down (preferred): when last compressor of the circuit stops, suction pressure is decreased 1.5 bar (22 psi) below nominal evaporating pressure with minimum of 1.7 bar(g) (25 psig). Even if suction pressure increases again, the compressor will not restart.
- Continuous pump-down: traditional pump-down, Compressor restarts automatically when suction pressure increases up to 4 cycles maximum.

For PSH019 to 039 compressors, an external Non-Return Valve (NRV) in the discharge line is recommended.

Reduce moisture in the system

GENERAL INFORMATION

- Excessive air and moisture
- can increase condensing pressure and cause high discharge temperatures.
 - can create acid giving rise to copper plating.
 - can destroy the lubricating properties of the oil.

All these phenomena can reduce service life and cause mechanical and electrical compressor failure.

Requirements

PSH019 to 039 compressors are delivered with < 100ppm moisture level.
At the time of commissioning, system moisture content may be up to 100ppm.

During operation, the filter drier must reduce this to a level between 20 and 50ppm.

PRODUCT INFORMATION

Solutions

To achieve this requirement, a properly sized and type of drier is required. Important selection criteria's include:

- driers water content capacity,
- system refrigeration capacity,
- system refrigerant charge.

For new installations with PSH019 to 039 compressors with polyolester oil, Danfoss recommends using the Danfoss DML (100% molecular sieve) solid core filter drier.

SYSTEM DESIGN

INTEGRATION INTO SYSTEM

ORDERING INFORMATION

Assembly line procedure

Compressor storage

Store the compressor not exposed to rain, corrosive or flammable atmosphere between -35°C (-31°F) and 70°C (158°F) when charged

with nitrogen and between -35°C (-31°F) and T_s max value (see section "Pressure equipment directive") when charged with R410A refrigerant.

Compressor holding charge

Each compressor is shipped with a nominal dry nitrogen holding charge between 0.3bar (4psi) and 0.7bar (10psi) and is sealed with elastomer plugs.

- Remove the suction plug first
- Remove the discharge plug afterwards
- ⚠ An opened compressor must not be exposed to air for more than 20 minutes to avoid moisture is captured by the POE oil.

Respect the following sequence to avoid discharge check valve gets stuck in open position:

Handling

⚠ Each Danfoss PSH019 to 039 scroll compressor is equipped with two lift rings on the top shell.

- Always use both these rings when lifting the compressor.
- Use lifting equipment rated and certified for the weight of the compressor or compressor assembly.
- A spreader bar rated for the weight of the compressor is highly recommended to ensure a better load distribution.

- The use of lifting hooks closed with a clasp is recommended.
- For tandem and trio assemblies, use a spreader bar and all compressor rings as shown in picture below.
- Never use the lift rings on the compressor to lift the full unit.

Maintain the compressor in an upright position during all handling manoeuvres (maximum of 15° from vertical).

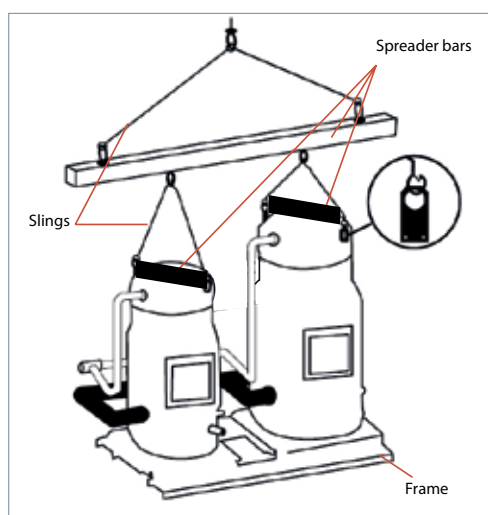
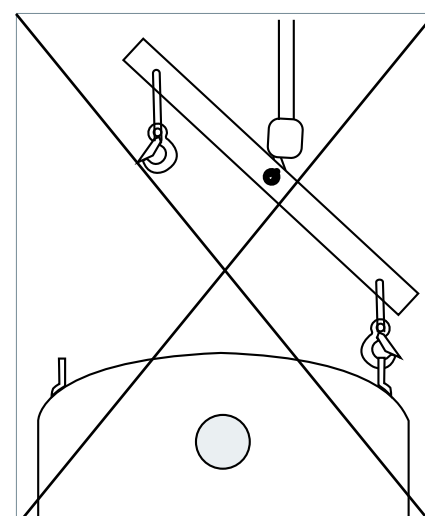
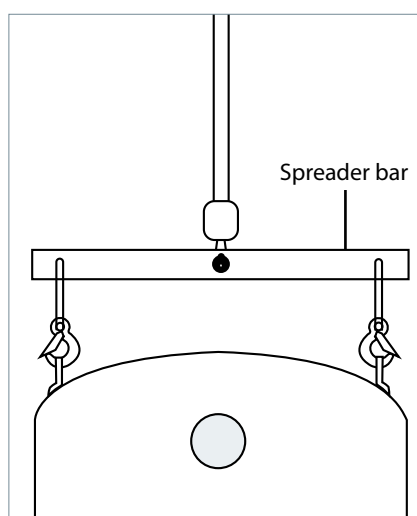

Piping assembly

Good practices for piping assembly is a pre-requisite to ensure compressor life time (system cleanliness, brazing procedure etc.)

System cleanliness

Circuit contamination possible cause:	Requirement:
Brazing and welding oxides	During brazing, flow nitrogen through the system.
Particles and burrs	Remove any particles and burrs generated by tube cutting and hole drilling.
Moisture and air	Use only clean and dehydrated refrigeration grade copper tubing. Opened compressor must not be exposed to air more than 20 minutes to avoid moisture captured by oil.

Brazing procedure:

- Brazing operations must be performed by qualified personnel.
- Make sure that no electrical wiring is connected to the compressor.
- To prevent compressor shell and electrical box overheating, use a heat shield and/or a heat-absorbent compound.
- Clean up connections with degreasing agent
- Flow nitrogen through the compressor.
- Use flux in paste or flux coated brazing rod.
- Use brazing rod with a minimum of 5% silver content.

- It is recommended to use double-tipped torch using acetylene to ensure a uniform heating of connection.
- For discharge connections brazing time should be less than 2 minutes to avoid NRVI damages if any.
- To enhance the resistance to rust, a varnish on the connection is recommended.

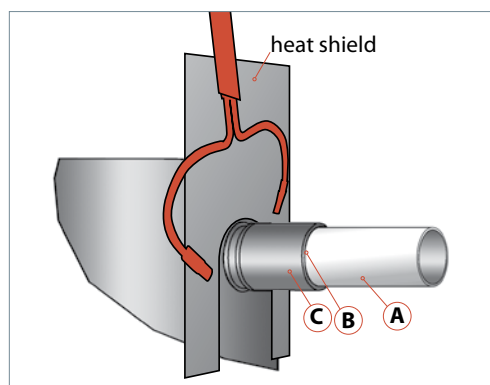

! Before eventual un-brazing of the compressor or any system component, the refrigerant charge must be removed.

System pressure test and leak detection

! The compressor has been strength tested and leak proof tested (<3g/year) at the factory. For system tests:

- Always use an inert gas such as Nitrogen or Helium.

- Pressurize the system on HP side first then LP side.
- Do not exceed the following pressures indicated in table below

Maximum compressor test pressures	PSH019-023-026-030-034-039
Maximum compressor test pressure high side (HP)	48.7 bar (g) (706 psig) HP-LP<37bar (537 psi)
Maximum compressor test pressure low side (LP)	33.3 bar (g) (483 psig) HP-LP<5bar (73 psi) Maximum speed 4.8 bar/s (70 psi/s)

GENERAL INFORMATION
PRODUCT INFORMATION
SYSTEM DESIGN
INTEGRATION INTO SYSTEM
ORDERING INFORMATION

Assembly line procedure

Vacuum evacuation and moisture removal



Requirements:

- Never use the compressor to evacuate the system.
- Connect a vacuum pump to both the LP and HP sides.
- Evacuate the system to a pressure of 500µm Hg (0.67mbar/0.02 in.Hg) absolute.

Recommendations:

- Energized heaters improve moisture removal.
- Alternate vacuum phases and break vacuum with Nitrogen to improve moisture removal.

For more detailed information see "Vacuum pump-down and dehydration procedure" TI-026-0302.

Refrigerant charging



Initial charge:

- For the initial charge, the compressor must not run.
- Charge refrigerant as close as possible to the nominal system charge.
- This initial charging operation must be done in liquid phase between the condenser outlet and the filter drier.

If needed, a complement of charge can be done before evaporator, in liquid phase while compressor is running by slowly throttling liquid in.

Never bypass safety low pressure switch.

For more detailed information see "Recommended refrigerant system charging practice" FRCC.EN.050.

Dielectric strength and insulation resistance tests

Several tests have been performed on each compressor at the factory between each phase and ground.

- Dielectric strength test is done with a high potential voltage (hi-pot) of 2Un +1000V AC at least, and leakage current must be less than 5mA.
- Insulation resistance is measured with a 500V DC megohm tester and must be higher than 1 megohm.

Recommendations:

- Additional dielectric test is not recommended as it may reduce motor lifetime. Nevertheless, if such as test is necessary, it must be performed at a lower voltage.
- Insulation resistance test can be done.
- The presence of refrigerant around the motor windings will result in lower resistance values to ground and higher leakage current readings. Such readings do not indicate a faulty compressor. To prevent this, the system can be first operated briefly to distribute refrigerant.



Do not use a megohm meter nor apply power to the compressor while it is under vacuum as this may cause internal damage.

Commissioning

Preliminary check

-  Check electrical power supply:
- Phase order: Reverse rotation is obvious if the compressor don't build up pressure and sound level is abnormal high. For PSH019 to 039 compressor have phase protection function on OCS. Reverse rotation will be automatically

detected and trip the compressor by opening the M1-M2 relay output. For more details refer to section "Motor protection".

- Voltage and voltage unbalance within tolerance: For more details refer to section "Motor voltage".

Initial start-up

- Surface sump heaters must be energized at least 6 hours in advance to remove refrigerant.
- A quicker start-up is possible by "jogging" the compressor to evacuate refrigerant. Start the

compressor for 1 second, then wait for 1 to 2 minutes. After 3 or 4 jogs the compressor can be started. This operation must be repeated for each compressor individually.

System monitoring

- The system must be monitored after initial startup for a minimum of 60 minutes to ensure proper operating characteristics such as:
- Correct superheat and subcooling.
 - Current draw of individual compressors within acceptable values (max operating current).
 - No abnormal vibrations and noise.
 - Correct oil level.

If Oil Top-up is needed, it must be done while the compressor is idle. Use the schrader connector or any other accessible connector on the compressor suction line. Always use original Danfoss POE oil 160SZ from new cans. For more detailed information see "Lubricants filling in instructions for Danfoss Commercial Compressors" TI 2-025-0402.

Dismantal and disposal



Danfoss recommends that compressors and compressor oil should be recycled by a suitable company at its site.

GENERAL INFORMATION

PRODUCT INFORMATION

SYSTEM DESIGN

INTEGRATION INTO SYSTEM

ORDERING INFORMATION

Ordering information and packaging

Packaging

Single pack



Compressor model	Length		Width		Height		Gross weight	
	mm	inch	mm	inch	mm	inch	kg	lbs
PSH019	565	22.24	470	18.50	718	28.27	69	152
PSH023	565	22.24	470	18.50	718	28.27	76	168
PSH026	565	22.24	470	18.50	718	28.27	76	168
PSH030	565	22.24	470	18.50	718	28.27	79	174
PSH034	565	22.24	470	18.50	718	28.27	81	179
PSH039	565	22.24	470	18.50	718	28.27	84	185

Industrial pack

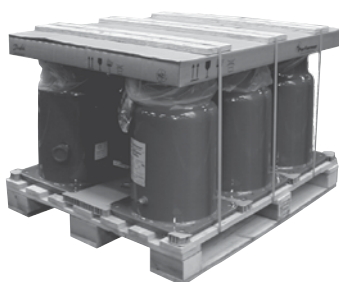

Compressor model	Nb *	Length		Width		Height		Gross weight		Static stacking pallets
		mm	inch	mm	inch	mm	inch	kg	lbs	
PSH019	6 ① / 8 ②	1150	45.28	950	37.40	680	26.77	386	851	2
PSH023	6 ① / 8 ②	1150	45.28	950	37.40	750	29.53	424	935	2
PSH026	6 ① / 8 ②	1150	45.28	950	37.40	750	29.53	424	935	2
PSH030	6 ① / 8 ②	1150	45.28	950	37.40	750	29.53	440	970	2
PSH034	6 ① / 8 ②	1150	45.28	950	37.40	750	29.53	452	996	2
PSH039	6 ① / 8 ②	1150	45.28	950	37.40	750	29.53	470	1036	2

* Nbr: number of compressor per pack

①: Full package version

②: Bare compressor version

Ordering information and packaging

Ordering information

Danfoss PSH019 to 039 scroll compressors can be ordered in either industrial or single packs.

Please use the code numbers from below tables for ordering:

Single pack

Compressor model	Connections	Code number		
		Motor code 3	Motor code 4	Motor code 9
PSH019	Full package	120H0963	120H0931	120H0987
PSH023		120H0965	120H0933	120H0989
PSH026		120H0967	120H0935	120H0991
PSH030		120H0969	120H0937	120H0993
PSH034		120H0971	120H0939	120H0995
PSH039		120H0973	120H0941	120H0997
PSH019	Bare compressor *		120H1398	
PSH023			120H1400	
PSH026			120H1402	
PSH030			120H1404	
PSH034			120H1406	
PSH039			120H1408	
PSH019	Simplified bare compressor **		120H0951	
PSH023			120H0953	
PSH026			120H0955	
PSH030			120H0957	
PSH034			120H0959	
PSH039			120H0961	

* Bare compressor doesn't have liquid injection control and liquid injection valve, only have liquid injection port.

** Simplified bare compressor doesn't have oil sight glass and oil balancing port compare with bare compressor.

Industrial pack

Compressor Model	Connections	Code number		
		Motor code 3	Motor code 4	Motor code 9
PSH019	Full package	120H0964	120H0932	120H0988
PSH023		120H0966	120H0934	120H0990
PSH026		120H0968	120H0936	120H0992
PSH030		120H0970	120H0938	120H0994
PSH034		120H0972	120H0940	120H0996
PSH039		120H0974	120H0942	120H0998
PSH019	Bare compressor *		120H1399	
PSH023			120H1401	
PSH026			120H1403	
PSH030			120H1405	
PSH034			120H1407	
PSH039			120H1409	
PSH019	Simplified bare compressor **		120H0952	
PSH023			120H0954	
PSH026			120H0956	
PSH030			120H0958	
PSH034			120H0960	
PSH039			120H0962	

* Bare compressor doesn't have liquid injection control and liquid injection valve, only have liquid injection port.

** Simplified bare compressor doesn't have oil sight glass and oil balancing port compare with bare compressor.

Accessories

Solder sleeve adapter sets



Type	Code no.	Description	Application	Packaging	Pack size
	120Z0125	Rotolock adaptor set (1"3/4 ~ 1"1/8) , (1"1/4 ~ 7/8")	PSH019	Multipack	8
	120Z0405	Rotolock adaptor set (1"3/4 ~ 1"3/8) , (1"1/4 ~ 7/8")	PSH023 to 039	Multipack	8

Rotolock adapter



Type	Code no.	Description	Application	Packaging	Pack size
	120Z0367	Adaptor (1"1/4 Rotolock - 7/8" ODF)	Models with 7/8" ODF	Multipack	10
	120Z0364	Adaptor (1"3/4 Rotolock - 1"1/8 ODF)	Models with 1"1/8 ODF	Multipack	10
	120Z0431	Adaptor (1"3/4 Rotolock - 1"3/8 ODF)	Models with 1"3/8 ODF	Multipack	10

Gaskets



Type	Code no.	Description	Application	Packaging	Pack size
G09	8156131	Gasket, 1"1/4	Models with 1"1/4 rotolock connection	Multipack	10
G09	7956002	Gasket, 1"1/4	Models with 1"1/4 rotolock connection	Industry pack	50
G07	8156132	Gasket, 1"3/4	Models with 1"3/4 rotolock connection	Multipack	10
G07	7956003	Gasket, 1"3/4	Models with 1"3/4 rotolock connection	Industry pack	50

Solder sleeve



Type	Code no.	Description	Application	Packaging	Pack size
P02	8153004	Solder sleeve P02 (1"3/4 Rotolock - 1"1/8 ODF)	Models with 1"3/4 rotolock connection	Multipack	10
P05	8153012	Rotolock connector P05 (1"1/4 Rotolock - 7/8" ODF)	Models with 1"1/4 rotolock connection	Multipack	10
P10	8153003	Solder sleeve P10 (1"3/4 Rotolock - 1"3/8 ODF)	Models with 1"3/4 rotolock connection	Multipack	10

Rotolock nut



Type	Code no.	Description	Application	Packaging	Pack size
	8153123	Rotolock nut, 1"1/4	Models with 1-1/4" rotolock connection	Multipack	10
	7953002	Rotolock nut, 1"1/4	Models with 1-1/4" rotolock connection	Industry pack	50
	8153124	Rotolock nut, 1"3/4	Models with 1-3/4" rotolock connection	Multipack	10
	7953003	Rotolock nut, 1"3/4	Models with 1-3/4" rotolock connection	Industry pack	50

Accessories

Rotolock service valve set



Type	Code no.	Description	Application	Packaging	Pack size
	7703008	Valve set, V02 (1"3/4 ~ 1"1/8), V05 (1"1/4 ~ 7/8")	PSH019	Multipack	6
	120Z0403	Valve set, V02 (1"3/4 ~ 1"1/8), V05 (1"1/4 ~ 7/8")	PSH019	Multipack	8
	7703392	Valve set, V10 (1"3/4 ~ 1"3/8), V05 (1"1/4 ~ 7/8")	PSH023 to 039	Multipack	6

* diameter restriction

3-phase soft start equipment



Type	Code no.	Description	Application	Packaging	Pack size
MCI 15 C	7705006	Electronic soft start kit, MCI 15 C	PSH019	Single pack	1
MCI 25 C	7705007	Electronic soft start kit, MCI 25 C	PSH023 to 030	Single pack	1
MCI 50 CM	037N0401	Electronic soft start kit, MCI 50 CM	PSH034 to 039	Single pack	1

Surface sump heaters

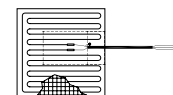

Type	Code no.	Accessory description	Application	Packaging	Pack size
	120Z0388	80W 24V surface sump heater CE & UL	PSH019 to 039	Multipack	8
	120Z0389	80W 230V surface sump heater CE & UL		Multipack	8
	120Z0390	80W 400V surface sump heater CE & UL		Multipack	8
	120Z0391	80W 460V surface sump heater CE & UL		Multipack	8
	120Z0402	80W 575V surface sump heater CE & UL		Multipack	8

Control boards

Type	Code no.	Description	Application	Packaging	Pack size
	120Z0689	Control board (OCS)	PSH019 to PSH039	Single pack	1
	120Z0698	PSH019 to PSH034 Ebox assembly with OCS	Old version PSH019 to PSH034 field replacement	Single pack	1
	120Z0699	PSH039 Ebox assembly with OCS	Old version PSH039 field replacement	Single pack	1

Sensors & cables



Type	Code no.	Description	Application	Packaging	Pack size
	120Z0534	Discharge temperature sensor PT1000	PSH019 to PSH039	Single pack	1

Accessories

Tandem kits



Type	Code no.	Description	Application	Packaging	Pack size
	7777054	Suction washer,rigid spacer, sleeve for oil connection	Even tandem	Single pack	1

Mounting kits



Type	Code no.	Description	Application	Packaging	Pack Size
	120Z0066	Mounting kit for scroll compressors. Grommets, sleeves, bolts, washers	PSH019 to 039	Single pack	1

Lubricant



Type	Code no.	Description	Application	Packaging	Pack Size
160SZ	7754023	POE lubricant, 1 litre can	All models	Multi pack	12
160SZ	120Z0571	POE lubricant, 2.5 litre can	All models	Multi pack	4

Miscellaneous



Type	Code no.	Description	Application	Packaging	Pack Size
	8156019	Sight glass with gaskets (black & white)	All models	Multi pack	4
	8156129	Gasket for oil sight glass, 1"1/8 (white teflon)	All models	Multi pack	10
	7956005	Gasket for oil sight glass, 1"1/8 (white teflon)	All models	Multi pack	50
	8154001	Danfoss Commercial Compressors blue spray paint	All models	Single pack	1

Danfoss Commercial Compressors

is a worldwide manufacturer of compressors and condensing units for refrigeration and HVAC applications. With a wide range of high quality and innovative products we help your company to find the best possible energy efficient solution that respects the environment and reduces total life cycle costs.

We have 40 years of experience within the development of hermetic compressors which has brought us amongst the global leaders in our business, and positioned us as distinct variable speed technology specialists. Today we operate from engineering and manufacturing facilities spanning across three continents.



Our products can be found in a variety of applications such as rooftops, chillers, residential air conditioners, heatpumps, coldrooms, supermarkets, milk tank cooling and industrial cooling processes.

<http://cc.danfoss.com>

Danfoss Commercial Compressors, BP 331, 01603 Trévoux Cedex, France | +334 74 00 28 29



Danfoss can accept no responsibility for possible errors in catalogues, brochures and other printed material. Danfoss reserves the right to alter its products without notice. This also applies to products already on order provided that such alterations can be made without subsequential changes being necessary in specifications already agreed. All trademarks in this material are property of the respective companies. Danfoss and the Danfoss logotype are trademarks of Danfoss A/S. All rights reserved.