

## Data Sheet

Solenoid valve  
Type **EVRS 3-20** and **EVRST 10-20**

Stainless steel solenoid valves used in liquid, suction, hot gas and oil return lines



EVRS and EVRST are valves made of stainless steel.

- EVRS 3 is direct operated.
- EVRS 10, 15 and 20 are servo operated.
- EVRST 10,15 and 20 are forced servo operated.

The valves are used in liquid, suction, hot gas and oil return lines with ammonia or fluorinated refrigerants.

EVRS 3 and EVRST are designed for keeping open at a pressure drop of 0 bar.

EVRS/EVRST 10, 15 and 20 are equipped with spindle for manual opening.

EVRS and EVRST are supplied as components, i.e. valve body and coil must be separately ordered.

**Features**

- Stainless steel valve body and connections
- Max. working pressure 50 barg
- Applicable to HCFC, HFC, R717 (Ammonia) and R744 (CO<sub>2</sub>)
- MOPD up to 38 bar with 20 watt a.c. coil
- Wide choice of a.c. and d.c. coils
- Designed for temperatures of media up to 105°C
- Manual stem on EVRS and EVRST 10, EVRST 15 and EVRST 20
- Classification: DNV, CRN, BV, EAC etc. To get an updated list of certification on the products please contact your local Danfoss Sales Company.

**Function**

Figure 1: EVRS 3, pipe thread

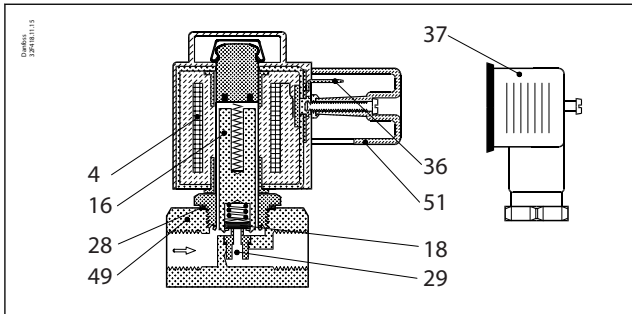

Figure 2: EVRS 3, weld

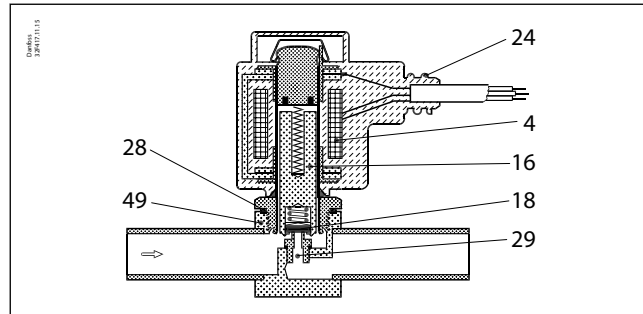

Figure 3: EVRS / EVRST 10 and 15

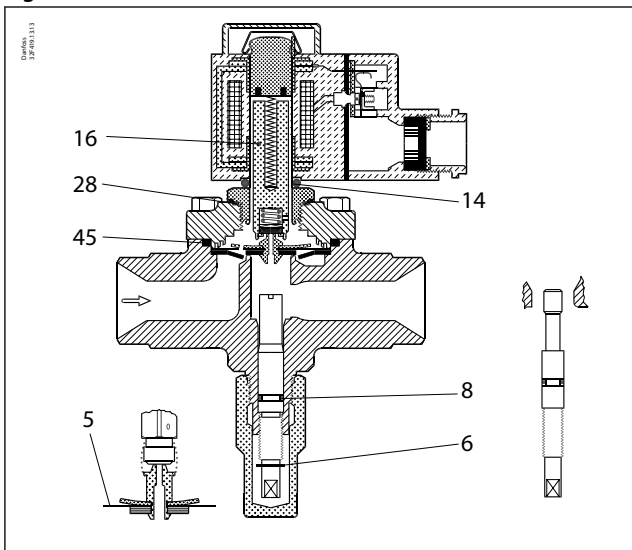
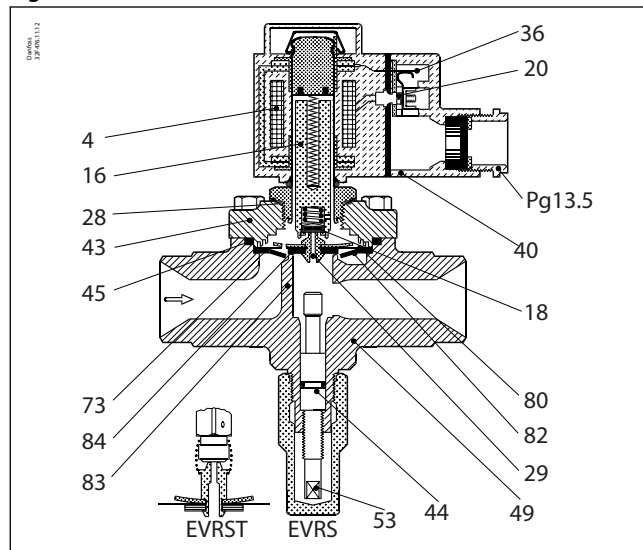

Figure 4: EVRS / EVRST 20



4.	Coil	29.	Pilot orifice	51.	Cover
16.	Armature	36.	DIN plug	53.	Manual operating spindle
18.	Pilot valve plate	40.	Terminal box	73.	Equalization hole
20.	Earth terminal	43.	Valve cover	80.	Diaphragm
24.	Connection for flexible steel hose	44.	O-ring	82.	Support washer
28.	Gasket	45.	Valve cover gasket	83.	Valve seat
		49.	Valve body	84.	Main valve plate

The solenoid valve design is based on three different principles:

1. Direct operation
2. Servo operation
3. Forced servo operation

**1. Direct operation**

EVRS 3 is directly operated. The valve opens direct for full flow when the armature (16) moves up into the magnetic field of the coil. This means that the valve operates with a min. differential pressure of 0 bar. The valve plate (18) made of teflon and is fitted direct to the armature (16).

Inlet pressure acts from above on the armature and with it the valve plate. Thus, inlet pressure, spring force and the weight of the armature act to close the valve when the coil is currentless.

**2. Servo operation**

EVRS 10, 15 and 20 are servo operated with a "floating" diaphragm (80). The pilot orifice (29), which is of stainless steel, is placed in the centre of the diaphragm. The teflon pilot valve plate (18) is fitted direct to the armature (16). With the coil currentless, the main orifice and pilot orifice are closed. The pilot orifice and main orifice are held closed by the weight of the armature, the armature spring force and the differential pressure between inlet and outlet sides.

When current is applied to the coil the armature is drawn up into the magnetic field and opens the pilot orifice. This relieves the pressure above the diaphragm because the space above the diaphragm becomes connected to the outlet side of the valve. The differential pressure between inlet and outlet sides then presses the diaphragm away from the main orifice which opens to full flow. Thus a certain minimum differential pressure is necessary to open the valve and keep it open. For EVRS 10, 15 and 20 valves this differential pressure is 0.05 bar. When current is switched off, the pilot orifice closes. Then the pressure above the diaphragm rises, via the equalization holes (73) in the diaphragm, to the inlet pressure and causes the diaphragm to close the main orifice.

### **3. Forced servo operation**

EVRST 10, 15 and 20 are forced servo operated solenoid valves. Forced servo operation differs from servo operation in that in a forced servo operated valve the armature and the diaphragm are connected by a spring. Thus the armature helps to lift the diaphragm (80) and keep it lifted so that the pressure drop in the open valve is the least possible. These types of valves therefore require no differential pressure to keep them open.

## Media

### **Refrigerants**

Applicable to HCFC, HFC, R717 (Ammonia) and R744 (CO<sub>2</sub>).

### **New refrigerants**

Danfoss products are continually evaluated for use with new refrigerants depending on market requirements.

When a refrigerant is approved for use by Danfoss, it is added to the relevant portfolio, and the R number of the refrigerant (e.g. R513A) will be added to the technical data of the code number. Therefore, products for specific refrigerants are best checked at [store.danfoss.com/en/](https://store.danfoss.com/en/), or by contacting your local Danfoss representative.

## Product specification

### Technical data

#### Temperature of medium

-40 °C / +105 °C for 10 or 12 watt coil. Max. 130 °C during defrosting. -40 °C / +80 °C for 20 watt coil.

Ambient temperature and enclosure for coil: See "Coils for solenoid valves"; lit.no. [AI237186440089](#)

Table 1: Technical data

Type	Opening differential pressure $\Delta p$ bar					kv value <sup>(2)</sup> m <sup>3</sup> /h	Max. working pressure Ps
	Min.	Max. (MOPD) liquid <sup>(1)</sup>					
		10 W a.c.	12 W a.c.	20 W a.c.	20 W d.c.		
EVRS 3	0.0	21	25	38	14	0.23	50 bar(g)
EVRS 10	0.05	21	25	38	18	1.5	
EVRST 10	0.0	14	21	38	16	1.5	
EVRS 15	0.05	21	25	38	18	2.7	
EVRST 15	0.0	14	21	38	18	2.7	
EVRS 20	0.05	21	25	38	13	4.5	
EVRST 20	0.0	14	21	38	13	4.5	

<sup>(1)</sup> MOPD for media in gas form is approx. 1 bar greater.

<sup>(2)</sup> The kv value is the water flow in m<sup>3</sup>/h at a pressure drop in the valve of 1 bar,  $\rho = 1000 \text{ kg/m}^3$ .

Table 2: Rated capacity

Type	Rated capacity <sup>(3)</sup> kW														
	Liquid					Suction vapour					Hot gas				
	R717	R22	R134a	R404A	R410A	R717	R22	R134a	R404A	R410A	R717	R22	R134a	R404A	R410A
EVRS 3	21.8	4.6	4.3	3.2	4.5						6.5	2.1	1.7	1.7	2.3
EVRS/EVRST 10	142	30.2	27.8	21.1	29.7	9	3.4	2.5	3.1	4.3	42.6	13.9	11	11.3	14.9
EVRS/EVRST 15	256	54.4	50.1	38	53.5	16.1	6.2	4.4	5.5	7.7	76.7	24.9	19.8	20.3	26.7
EVRS/EVRST 20	426	90.6	83.5	63.3	89.1	26.9	10.3	7.3	9.2	12	128	41.5	32.9	33.9	44.5

<sup>(3)</sup> Rated liquid and suction vapour capacity is based on evaporating temperature  $t_e = -10 \text{ °C}$ , liquid temperature ahead of valve  $t_l = +25 \text{ °C}$ , and pressure drop across valve  $\Delta p = 0.15 \text{ bar}$ . Rated hot gas capacity is based on condensing temperature  $t_c = +40 \text{ °C}$ , pressure drop across valve  $\Delta p = 0.8 \text{ bar}$ , hot gas temperature  $t_h = +60 \text{ °C}$ , and subcooling of refrigerant  $\Delta t_{\text{sub}} = 4 \text{ K}$ .

Table 3: Rated capacity

Type	R 744 Rated capacity kW <sup>(4)</sup>	
	Liquid	Suction
EVRS 3	6.65	-
EVRS/ EVRST 10	43.3	6.9
EVRS/ EVRST 15	78	12.4
EVRS/ EVRST 20	130	20.7

<sup>(4)</sup> Rated liquid and suction vapour capacity is based on evaporating temperature  $t_e = -40 \text{ °C}$ , liquid temperature ahead of the valve  $t_l = -8 \text{ °C}$  and pressure drop across the valve  $\Delta p = 0.15 \text{ bar}$ . For other condition please refer to DIR-Calc or contact your local Danfoss office.

### Capacity

#### Liquid capacity $Q_l$ kW

Table 4: R717 (NH<sub>3</sub>)

Type	Liquid capacity $Q_e$ kW at pressure drop across valve $\Delta p$ bar				
	0.1	0.2	0.3	0.4	0.5
EVRS 3	17.8	25.1	30.8	35.6	39.8
EVRS/EVRST 10	116.0	164.0	201.0	232.0	259.0
EVRS/EVRST 15	209.0	295.0	362.0	418.0	467.0
EVRS/EVRST 20	348.0	492.0	603.0	696.0	778.0

## Solenoid valve, Type EVRS 3-20 and EVRST 10-20

**Table 5: R22**

Type	Liquid capacity $Q_e$ kW at pressure drop across valve $\Delta p$ bar				
	0.1	0.2	0.3	0.4	0.5
EVRS 3	3.8	5.3	6.6	7.6	8.5
EVRS/EVRST 10	24.7	34.9	42.7	49.3	55.1
EVRS/EVRST 15	44.4	62.8	76.9	88.8	99.2
EVRS/EVRST 20	73.9	105.0	128.0	148.0	165.0

**Table 6: R134a**

Type	Liquid capacity $Q_e$ kW at pressure drop across valve $\Delta p$ bar				
	0.1	0.2	0.3	0.4	0.5
EVRS 3	3.5	4.9	6.0	7.0	7.8
EVRS/EVRST 10	22.7	32.2	39.4	45.5	50.8
EVRS/EVRST 15	40.9	57.9	70.9	81.8	91.5
EVRS/EVRST 20	68.2	96.5	118.0	136.0	153.0

**Table 7: R404A**

Type	Liquid capacity $Q_e$ kW at pressure drop across valve $\Delta p$ bar				
	0.1	0.2	0.3	0.4	0.5
EVRS 3	2.6	3.7	4.6	5.3	5.9
EVRS/EVRST 10	17.2	24.3	29.8	34.4	38.5
EVRS/EVRST 15	31.0	43.8	53.7	62.0	69.3
EVRS/EVRST 20	51.7	73.0	89.5	103.0	116.0

**Table 8: R410A**

Type	Liquid capacity $Q_e$ kW at pressure drop across valve $\Delta p$ bar				
	0.1	0.2	0.3	0.4	0.5
EVRS 3	3.7	5.3	6.4	7.5	8.3
EVRS/EVRST 10	24.3	34.4	42	48.6	54.3
EVRS/EVRST 15	43.7	61.8	75.6	87.5	97.7
EVRS/EVRST 20	72.9	103	126	146	163

**NOTE:**

Capacities are based on liquid temperature  $t_l = +25$  °C ahead of valve, evaporating temperature  $t_e = -10$  °C, and superheat 0 K.

**Correction factors**

When sizing valves, the table value must be multiplied by a correction factor depending on evaporating temperature  $t_e$ .

**Table 9: Correction factors**

$t_e$ °C	-10	0	+10	+20	+25	+30	+40	+50
R717 (NH <sub>3</sub> )	0.84	0.88	0.92	0.97	1	1.03	1.09	1.16
R22, R134a	0.76	0.81	0.88	0.96	1	1.05	1.16	1.31
R404A	0.7	0.76	0.84	0.94	1	1.07	1.24	1.47
R410A	0.73	0.79	0.86	0.95	1	1.06	1.23	1.47

**Suction vapour capacity  $Q_e$  kW**

**Table 10: R717 (NH<sub>3</sub>)**

Type	Pressure drop across valve $\Delta p$ bar	Suction vapour capacity $Q_e$ kW at evaporating temperature $t_e$ °C					
		-40	-30	-20	-10	0	+10
EVRS/EVRST 10	0.1	3.4	4.5	5.9	7.3	8.9	10.6
	0.15	4.0	5.4	7.0	9.0	10.9	13.0
	0.2	4.5	6.1	7.9	10.0	12.6	15.0
EVRS/EVRST 15	0.1	6.1	8.1	10.7	13.2	16.0	19.1
	0.15	7.2	9.7	12.5	16.1	19.6	23.4
	0.2	8.0	11.0	14.2	18.0	22.6	27.0

## Solenoid valve, Type EVRS 3-20 and EVRST 10-20

Type	Pressure drop across valve $\Delta p$ bar	Suction vapour capacity $Q_e$ kW at evaporating temperature $t_e$ °C					
		-40	-30	-20	-10	0	+10
EVRS/EVRST 20	0.1	10.2	13.5	17.8	21.9	26.6	31.9
	0.15	12.1	16.1	20.9	26.9	32.6	39.0
	0.2	13.4	18.3	23.7	29.9	37.7	45.1

**Table 11: R22**

Type	Pressure drop across valve $\Delta p$ bar	Suction vapour capacity $Q_e$ kW at evaporating temperature $t_e$ °C					
		-40	-30	-20	-10	0	+10
EVRS/EVRST 10	0.1	1.4	1.8	2.3	2.8	3.4	4.0
	0.15	1.6	2.1	2.7	3.4	4.1	4.9
	0.2	1.8	2.4	3.1	3.8	4.8	5.6
EVRS/EVRST 15	0.1	2.5	3.2	4.1	5.0	6.1	7.2
	0.15	2.9	3.8	4.8	6.2	7.4	8.8
	0.2	3.3	4.3	5.5	6.8	8.6	10.2
EVRS/EVRST 20	0.1	4.1	5.3	6.8	8.4	10.1	12.0
	0.15	4.9	6.4	8.1	10.3	12.3	14.7
	0.2	5.5	7.2	9.2	11.4	14.3	16.9

**Table 12: R134a**

Type	Pressure drop across valve $\Delta p$ bar	Suction vapour capacity $Q_e$ kW at evaporating temperature $t_e$ °C					
		-40	-30	-20	-10	0	+10
EVRS/EVRST 10	0.1	0.87	1.2	1.6	2.1	2.6	3.2
	0.15	0.99	1.4	1.9	2.4	3.2	3.9
	0.2	1.1	1.6	2.1	2.8	3.5	4.5
EVRS/EVRST 15	0.1	1.6	2.1	2.8	3.8	4.7	5.7
	0.15	1.8	2.5	3.4	4.4	5.7	7.0
	0.2	2.0	2.8	3.8	5.0	6.3	8.1
EVRS/EVRST 20	0.1	2.6	3.6	4.7	6.3	7.8	9.6
	0.15	3.0	4.2	5.6	7.3	9.5	11.7
	0.2	3.3	4.7	6.4	8.3	10.5	13.5

**Table 13: R404a**

Type	Pressure drop across valve $\Delta p$ bar	Suction vapour capacity $Q_e$ kW at evaporating temperature $t_e$ °C					
		-40	-30	-20	-10	0	+10
EVRS/EVRST 10	0.1	1.2	1.5	2.0	2.5	3.1	3.7
	0.15	1.4	1.8	2.4	3.1	3.8	4.6
	0.2	1.6	2.1	2.7	3.4	4.3	5.3
EVRS/EVRST 15	0.1	2.1	2.7	3.6	4.5	5.5	6.6
	0.15	2.5	3.3	4.3	5.5	6.8	8.2
	0.2	2.8	3.7	4.9	6.1	7.8	9.5
EVRS/EVRST 20	0.1	3.5	4.6	6.0	7.5	9.2	11.1
	0.15	4.1	5.5	7.1	9.2	11.3	13.6
	0.2	4.6	6.2	8.1	10.2	13.0	15.8

**Table 14: R410A**

Type	Pressure drop across valve $\Delta p$ bar	Suction vapour capacity $Q_e$ kW at evaporating temperature $t_e$ °C					
		-40	-30	-20	-10	0	+10
EVRS/EVRST 10	0.1	1.9	2.3	2.9	3.5	4.2	5.0
	0.15	2.2	2.9	3.5	4.3	5.1	6.1
	0.2	2.6	3.3	4.0	5.0	5.9	7.0
EVRS/EVRST 15	0.1	3.3	4.2	5.2	6.3	7.6	9.0
	0.15	4.0	5.1	6.3	7.7	9.2	11.0
	0.2	4.7	5.9	7.3	8.9	10.7	12.7
EVRS/EVRST 20	0.1	5.6	7.0	8.6	10.5	12.6	15.0
	0.15	6.7	8.6	10.5	12.9	15.4	18.4
	0.2	7.8	9.9	12.2	14.9	17.8	21.2

## Solenoid valve, Type EVRS 3-20 and EVRST 10-20

### NOTE:

- Capacities are based on liquid temperature  $t_l = +25$  °C ahead of evaporator.
- The table values refer to the evaporator capacity and are given as a function of evaporating temperature  $t_e$  and pressure drop  $\Delta p$  in valve.
- Capacities are based on dry, saturated vapour ahead of valve. During operation with superheated vapour ahead of valve, the capacities are reduced by 4% for each 10 K superheat.

### Correction factors

When sizing valves, the evaporator capacity must be multiplied by a correction factor depending on liquid temperature  $t_l$  ahead of expansion valve.

When the corrected capacity is known, the selection can be made from the table.

**Table 15: Correction factors**

$t_v$ °C	-10	0	+10	+20	+25	+30	+40	+50
R717 (NH3)	0.84	0.88	0.92	0.97	1.0	1.03	1.09	1.16
R22, R134a	0.76	0.81	0.88	0.96	1.0	1.05	1.16	1.31
R404A	0.70	0.76	0.84	0.94	1.0	1.07	1.24	1.47
R410A	0.76	0.80	0.89	0.96	1.0	1.05	1.18	1.37

**Table 16: R717 (NH<sub>3</sub>)**

Type	Pressure drop across valve $\Delta p$ bar	Hot gas capacity $Q_h$ Kw				
		Evaporating temp. $t_e = -10$ °C. Hot gas temp. $t_h = t_c + 25$ °C. Subcooling $\Delta t_{sub} = 4$ K				
		Condensing temperature $t_c$ °C				
		+20	+30	+40	+50	+60
EVRS 3	0.1	1.8	2.1	2.3	2.5	2.6
	0.2	2.6	2.9	3.2	3.5	3.7
	0.4	3.8	4.2	4.6	4.9	5.3
	0.8	5.1	6.0	6.5	7.1	7.6
	1.6	7.4	8.3	9.1	9.9	10.9
EVRST 10	0.1	12.0	3.4	14.7	16.0	17.2
	0.2	17.1	19.0	20.9	22.7	24.4
	0.4	24.5	27.1	29.7	32.2	34.7
	0.8	34.0	39.0	42.6	46.1	49.5
	1.6	48.5	53.8	59.1	64.3	1.3
EVRST 15	0.1	21.7	24.1	26.4	28.8	31.0
	0.2	30.8	34.2	37.5	40.8	44.0
	0.4	44.1	48.8	53.5	58.0	62.4
	0.8	61.2	70.3	76.7	83.0	89.1
	1.6	87.4	96.9	106.0	116.0	128.0
EVRST 20	0.1	36.1	40.1	44.0	48.0	51.7
	0.2	51.4	57.0	62.6	68.0	73.2
	0.4	73.5	81.3	89.1	96.7	104.0
	0.8	102.0	117.0	128.0	138.0	148.0
	1.6	146.0	161.0	177.0	193.0	214.0

**Table 17: R22**

Type	Pressure drop across valve $\Delta p$ bar	Hot gas capacity $Q_h$ Kw				
		Evaporating temp. $t_e = -10$ °C. Hot gas temp. $t_h = t_c + 25$ °C. Subcooling $\Delta t_{sub} = 4$ K				
		Condensing temperature $t_c$ °C				
		+20	+30	+40	+50	+60
EVRS 3	0.1	0.68	0.72	0.76	0.78	0.79
	0.2	0.97	1.0	1.1	1.1	1.1
	0.4	1.4	1.5	1.5	1.6	1.6
	0.8	1.9	2.0	2.1	2.3	2.3
	1.6	2.7	2.9	3.0	3.1	3.2

## Solenoid valve, Type EVRS 3-20 and EVRST 10-20

Type	Pressure drop across valve $\Delta p$ bar	Hot gas capacity $Q_h$ Kw				
		Evaporating temp. $t_e = -10$ °C. Hot gas temp. $t_h = t_c + 25$ °C. Subcooling $\Delta t_{sub} = 4$ K				
		Condensing temperature $t_c$ °C				
		+20	+30	+40	+50	+60
EVRS/EVRST 10	0.1	4.4	4.7	4.9	5.1	5.2
	0.2	6.3	6.7	7.0	7.2	7.3
	0.4	9.0	9.6	10.0	10.3	10.4
	0.8	12.4	13.2	13.9	14.7	14.9
	1.6	17.5	18.6	19.6	20.2	20.5
EVRS/EVRST 15	0.1	8.0	8.5	8.9	9.2	9.3
	0.2	11.4	12.1	12.6	13.0	13.2
	0.4	16.3	17.2	18.0	18.5	18.7
	0.8	22.3	23.1	24.9	26.5	26.8
	1.6	31.5	33.5	35.2	36.4	36.9
EVRS/EVRST 20	0.1	13.3	14.1	14.8	15.3	15.5
	0.2	19	20.1	21	21.7	22.0
	0.4	27.1	28.7	30	30.9	31.2
	0.8	37.1	38.4	44.5	44.2	44.6
	1.6	52.5	55.9	58.6	60.6	61.5

### NOTE:

- An increase in hot gas temperature  $t_h$  of 10 K reduces valve capacity approx. 2% and vice versa.
- A change in evaporating temperature  $t_e$  changes valve capacity; see correction factor table below.

### Correction factors

When sizing valves, the table value must be multiplied by a correction factor depending on evaporating temperature  $t_e$ .

Table 18: Correction factors

$t_e$ °C	-40	-30	-20	-10	0	+10
R717 (NH <sub>3</sub> )	0.89	0.91	0.96	1.0	1.06	1.10
R22	0.90	0.94	0.97	1.0	1.03	1.05

### Hot gas capacity $Q_h$ kW

Table 19: R134a

Type	Pressure drop across valve $\Delta p$ bar	Hot gas capacity $Q_h$ Kw				
		Evaporating temp. $t_e = -10$ °C. Hot gas temp. $t_h = t_c + 25$ °C. Subcooling $\Delta t_{sub} = 4$ K				
		Condensing temperature $t_c$ °C				
		+20	+30	+40	+50	+60
EVRS 3	0.1	0.54	0.57	0.6	0.61	0.6
	0.2	0.77	0.82	0.85	0.86	0.85
	0.4	1.1	1.2	1.2	1.2	1.2
	0.8	1.5	1.6	1.7	1.8	1.8
	1.6	2.2	2.3	2.4	2.5	2.4
EVRS/EVRST 10	0.1	3.5	3.7	3.9	4.0	3.9
	0.2	5.0	5.3	5.5	5.6	5.6
	0.4	7.0	7.7	7.9	8.0	7.9
	0.8	9.9	10.5	11.0	11.6	11.4
	1.6	14.3	15.1	15.7	16.0	15.9
EVRS/EVRST 15	0.1	6.4	6.7	7.0	7.1	7.1
	0.2	9.1	9.6	10.0	10.1	10.0
	0.4	12.6	13.8	14.2	14.4	14.3
	0.8	17.9	19.0	19.8	20.8	20.5
	1.6	25.7	27.2	28.2	28.8	28.6

## Solenoid valve, Type EVRS 3-20 and EVRST 10-20

Type	Pressure drop across valve $\Delta p$ bar	Hot gas capacity $Q_h$ Kw				
		Evaporating temp. $t_e = -10$ °C. Hot gas temp. $t_h = t_c + 25$ °C. Subcooling $\Delta t_{sub} = 4$ K				
		Condensing temperature $t_c$ °C				
		+20	+30	+40	+50	+60
EVRS/EVRST 20	0.1	10.6	11.2	11.7	11.8	11.8
	0.2	15.1	16.0	16.6	16.8	16.7
	0.4	21.0	22.9	23.7	24.0	23.8
	0.8	29.8	31.6	33.0	34.7	34.2
	1.6	42.8	45.3	47.1	47.9	47.6

**Table 20: R404A**

Type	Pressure drop across valve $\Delta p$ bar	Hot gas capacity $Q_h$ Kw				
		Evaporating temp. $t_e = -10$ °C. Hot gas temp. $t_h = t_c + 25$ °C. Subcooling $\Delta t_{sub} = 4$ K				
		Condensing temperature $t_c$ °C				
		+20	+30	+40	+50	+60
EVRS 3	0.1	0.62	0.63	0.62	0.59	0.54
	0.2	0.87	0.89	0.88	0.83	0.76
	0.4	1.2	1.3	1.3	1.2	1.1
	0.8	1.7	1.7	1.7	1.7	1.5
	1.6	2.4	2.5	2.4	2.3	2.1
EVRS/EVRST 10	0.1	4.0	4.1	4.0	3.8	3.5
	0.2	5.7	5.8	5.7	5.5	5.0
	0.4	8.1	8.2	8.2	7.8	7.0
	0.8	11.1	11.4	11.3	11.1	10.1
	1.6	15.7	16.0	15.8	15.2	13.9
EVRS/EVRST 15	0.1	7.3	7.4	7.3	6.9	6.3
	0.2	10.2	10.4	10.3	9.8	8.9
	0.4	14.6	14.8	14.7	14.0	12.7
	0.8	20.1	20.4	20.3	20.0	18.1
	1.6	28.3	28.8	28.4	27.4	25.0
EVRS/EVRST 20	0.1	12.1	12.3	12.1	11.5	10.5
	0.2	17.1	17.3	17.2	16.3	14.9
	0.4	24.4	24.7	24.5	23.3	21.1
	0.8	33.4	34.0	33.9	33.3	30.2
	1.6	47.1	48.0	47.4	45.6	41.6

**NOTE:**

An increase in hot gas temperature  $t_h$  of 10 K reduces valve capacity approx. 2% and vice versa. A change in evaporating temperature  $t_e$  changes valve capacity; see correction factor table below.

### Correction factors

When sizing valves, the table value must be multiplied by a correction factor depending on evaporating temperature  $t_e$ .

**Table 21: Correction factors**

$t_e$ °C	-40	-30	-20	-10	0	+10
R404A	0.86	0.88	0.93	1	1.03	1.07
R134a	0.88	0.92	0.98	1	1.04	1.08

**Table 22: R410A**

Type	Pressure drop across valve $\Delta p$ bar	Hot gas capacity $Q_h$ Kw				
		Evaporating temp. $t_e = -10$ °C. Hot gas temp. $t_h = t_c + 25$ °C. Subcooling $\Delta t_{sub} = 4$ K				
		Condensing temperature $t_c$ °C				
		+20	+30	+40	+50	+60
EVRS 3	0.1	0.8	0.8	0.8	0.8	0.7
	0.2	1.1	1.1	1.1	1.1	1
	0.4	1.6	1.6	1.6	1.6	1.5
	0.8	2.2	2.7	2.2	2.2	2.1
	1.6	3.1	3.2	3.2	3.2	2.9

## Solenoid valve, Type EVRS 3-20 and EVRST 10-20

Type	Pressure drop across valve $\Delta p$ bar	Hot gas capacity $Q_h$ Kw				
		Evaporating temp. $t_e = -10$ °C. Hot gas temp. $t_h = t_e + 25$ °C. Subcooling $\Delta t_{sub} = 4$ K				
		Condensing temperature $t_c$ °C				
		+20	+30	+40	+50	+60
EVRS/EVRST 10	0.1	5.1	5.2	5.3	5.2	4.8
	0.2	7.2	7.4	7.4	7.3	6.8
	0.4	10.2	10.4	10.5	10.3	9.6
	0.8	14.4	14.8	14.9	14.5	13.7
	1.6	20.3	20.8	21	20.5	19.1
EVRS/EVRST 15	0.1	9.2	9.4	9.4	9.3	8.6
	0.2	13	13.3	13.3	13.1	12.2
	0.4	18.4	18.8	18.9	18.5	17.2
	0.8	25.9	26.6	26.7	26.1	24.6
	1.6	36.6	37.5	37.8	36.9	34.5
EVRS/EVRST 20	0.1	15.3	15.7	15.8	15.5	14.4
	0.2	21.6	22.1	22.2	21.8	20.3
	0.4	30.6	31.3	31.5	30.8	28.7
	0.8	43.2	44.3	44.6	43.5	41
	1.6	61	62.6	63	61.6	57.4

### NOTE:

An increase in hot gas temperature  $t_h$  of 10 K reduces valve capacity approx. 2% and vice versa.

A change in evaporating temperature  $t_e$  changes valve capacity; see correction factor table below.

### Correction factors

When sizing valves, the table value must be multiplied by a correction factor depending on evaporating temperature  $t_e$ .

Table 23: Correction factors

$t_e$ °C	-40	-30	-20	-10	0	+10
R410A	0.92	0.95	0.98	1	1.02	1.03

Table 24: R717 (NH<sub>3</sub>)

Type	Hot gas temperature $t_h$ °C	Condensing temperature $t_c$ °C	Hot gas capacity $G_h$ kg/s at pressure drop across valve $\Delta p$ bar								
			0.5	1	2	3	4	5	6	7	8
EVRS 3	90	25	0.003	0.005	0.006	0.007	0.007	0.007	0.007	0.007	0.007
		35	0.004	0.005	0.007	0.009	0.009	0.01	0.01	0.01	0.01
		45	0.005	0.006	0.009	0.01	0.011	0.012	0.013	0.013	0.013
EVRS/EVRST 10		25	0.022	0.03	0.04	0.045	0.048	0.048	0.048	0.048	0.048
		35	0.026	0.036	0.048	0.056	0.061	0.064	0.065	0.065	0.065
		45	0.03	0.041	0.056	0.066	0.074	0.079	0.083	0.085	0.086
EVRS/EVRST 15		25	0.04	0.054	0.072	0.081	0.086	0.087	0.087	0.087	0.087
		35	0.046	0.064	0.086	0.100	0.109	0.115	0.117	0.117	0.117
		45	0.053	0.074	0.101	0.120	0.133	0.142	0.149	0.153	0.155
EVRS/EVRST 20	25	0.066	0.09	0.12	0.12	0.144	0.145	0.145	0.145	0.145	
	35	0.077	0.107	0.144	0.167	0.182	0.191	0.195	0.195	0.195	
	45	0.089	0.124	0.169	0.199	0.211	0.237	0.248	0.255	0.258	

## Solenoid valve, Type EVRS 3-20 and EVRST 10-20

**Table 25: R22**

Type	Hot gas temperature $t_h$ °C	Condensing temperature $t_c$ °C	Hot gas capacity $G_h$ kg/s at pressure drop across valve $\Delta p$ bar									
			0.5	1	2	3	4	5	6	7	8	
EVRS 3	90	25	0.008	0.011	0.014	0.016	0.017	0.017	0.017	0.017	0.017	0.017
		35	0.009	0.012	0.017	0.019	0.021	0.022	0.022	0.022	0.022	0.022
		45	0.01	0.014	0.019	0.022	0.025	0.026	0.027	0.028	0.028	0.028
EVRS/EVRST 10		25	0.051	0.069	0.092	0.104	0.109	0.111	0.111	0.111	0.111	0.111
		35	0.058	0.08	0.108	0.125	0.136	0.142	0.144	0.144	0.144	0.144
		45	0.066	0.092	0.125	0.146	0.162	0.172	0.179	0.183	0.183	0.183
EVRS/EVRST 15		25	0.091	0.125	0.165	0.187	0.197	0.199	0.199	0.199	0.199	0.199
		35	0.105	0.144	0.194	0.225	0.244	0.256	0.258	0.258	0.258	0.258
		45	0.119	0.165	0.224	0.263	0.291	0.31	0.322	0.329	0.33	0.33
EVRS/EVRST 20	25	0.152	0.208	0.275	0.311	0.328	0.332	0.332	0.332	0.332	0.332	
	35	0.174	0.241	0.323	0.375	0.407	0.425	0.431	0.431	0.431	0.431	
	45	0.193	0.275	0.374	0.439	0.485	0.516	0.537	0.548	0.55	0.55	

**Table 26: R134a**

Type	Hot gas temperature $t_h$ °C	Condensing temperature $t_c$ °C	Hot gas capacity $G_h$ kg/s at pressure drop across valve $\Delta p$ bar									
			0.5	1	2	3	4	5	6	7	8	
EVRS 3	60	25	0.007	0.009	0.011	0.012	0.012					
		35	0.009	0.011	0.014	0.016	0.016	0.016	0.016			
		45	0.01	0.012	0.018	0.02	0.021	0.021	0.021	0.021	0.021	0.021
EVRS/EVRST 10		25	0.048	0.06	0.074	0.077	0.077					
		35	0.055	0.071	0.092	0.103	0.104	0.104				
		45	0.06	0.084	0.111	0.127	0.134	0.135	0.135	0.135	0.135	0.135
EVRS/EVRST 15		25	0.081	0.108	0.134	0.14	0.14					
		35	0.094	0.129	0.166	0.192	0.187	0.187	0.187			
		45	0.108	0.151	0.2	0.228	0.241	0.244	0.244	0.244	0.244	0.244
EVRS/EVRST 20	25	0.134	0.18	0.223	0.233	0.233						
	35	0.157	0.215	0.276	0.307	0.312	0.312	0.312				
	45	0.181	0.252	0.333	0.381	0.403	0.407	0.407	0.407	0.407	0.407	

**Table 27: R404A**

Type	Hot gas temperature $t_h$ °C	Condensing temperature $t_c$ °C	Hot gas capacity $G_h$ kg/s at pressure drop across valve $\Delta p$ bar									
			0.5	1	2	3	4	5	6	7	8	
EVRS 3	60	25	0.01	0.013	0.018	0.021	0.022	0.023	0.023	0.023	0.023	0.023
		35	0.011	0.015	0.02	0.024	0.027	0.028	0.029	0.029	0.029	0.03
		45	0.012	0.017	0.023	0.028	0.032	0.034	0.035	0.036	0.036	0.037
EVRS/EVRST 10		25	0.063	0.087	0.116	0.134	0.145	0.148	0.149	0.149	0.149	0.149
		35	0.072	0.1	0.134	0.158	0.174	0.184	0.19	0.19	0.19	0.192
		45	0.081	0.112	0.153	0.182	0.203	0.228	0.228	0.237	0.237	0.239
EVRS/EVRST 15		25	0.113	0.157	0.21	0.242	0.26	0.267	0.269	0.269	0.269	0.269
		35	0.129	0.18	0.242	0.285	0.313	0.332	0.341	0.342	0.346	0.346
		45	0.146	0.202	0.275	0.327	0.365	0.393	0.411	0.424	0.431	0.431
EVRS/EVRST 20	25	0.189	0.262	0.350	0.403	0.433	0.445	0.449	0.449	0.449	0.449	
	35	0.215	0.300	0.404	0.474	0.521	0.552	0.569	0.57	0.576	0.576	
	45	0.243	0.337	0.459	0.545	0.609	0.656	0.684	0.707	0.719	0.719	

Table 28: R410A

Type	Hot gas temperature $t_h$ °C	Condensing temperature $t_c$ °C	Hot gas capacity $G_h$ kg/s at pressure drop across valve $\Delta p$ bar								
			0.5	1	2	3	4	5	6	7	8
EVRS 3	90	25	0.009	0.013	0.018	0.022	0.025	0.028	0.031	0.031	0.031
		35	0.01	0.014	0.02	0.025	0.029	0.032	0.035	0.038	0.038
		45	0.012	0.016	0.023	0.029	0.033	0.037	0.04	0.044	0.047
EVRS/EVRST 10		25	0.059	0.083	0.117	0.144	0.166	0.185	0.201	0.201	0.201
		35	0.067	0.094	0.133	0.163	0.189	0.211	0.231	0.249	0.249
		45	0.076	0.108	0.152	0.186	0.215	0.241	0.263	0.285	0.304
EVRS/EVRST 15		25	0.106	0.15	0.211	0.259	0.3	0.334	0.361	0.361	0.361
		35	0.12	0.17	0.24	0.294	0.34	0.38	0.416	0.449	0.449
		45	0.137	0.194	0.274	0.335	0.387	0.433	0.474	0.513	0.548
EVRS/EVRST 20	25	0.177	0.149	0.352	0.431	0.498	0.556	0.602	0.602	0.602	
	35	0.2	0.283	0.4	0.49	0.566	0.633	0.693	0.748	0.748	
	45	0.228	0.323	0.456	0.558	0.645	0.722	0.79	0.854	0.913	

**NOTE:**

An increase in hot gas temperature  $t_h$  of 10 K reduces valve capacity approx. 2% and vice versa.

**Material specification**

Figure 5: EVRS 3, Pipe thread

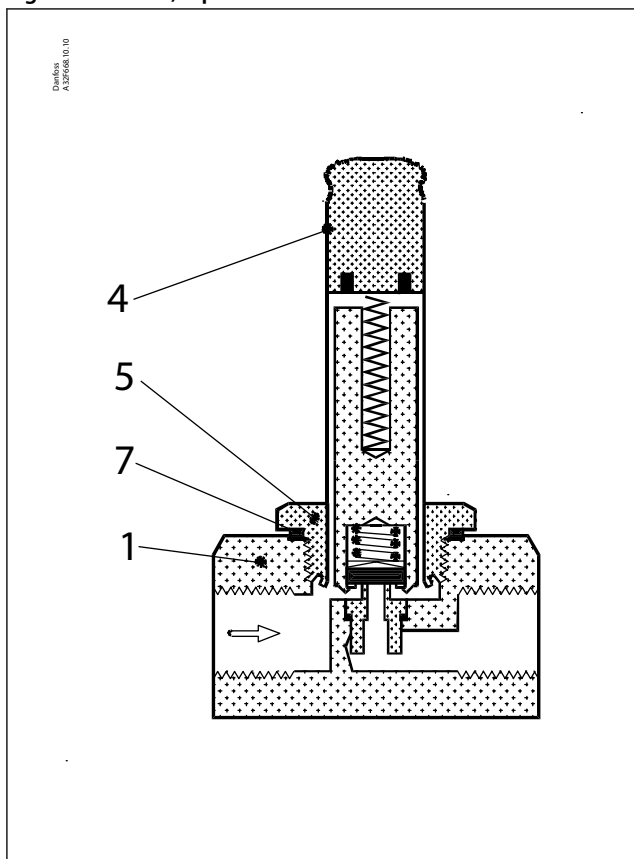
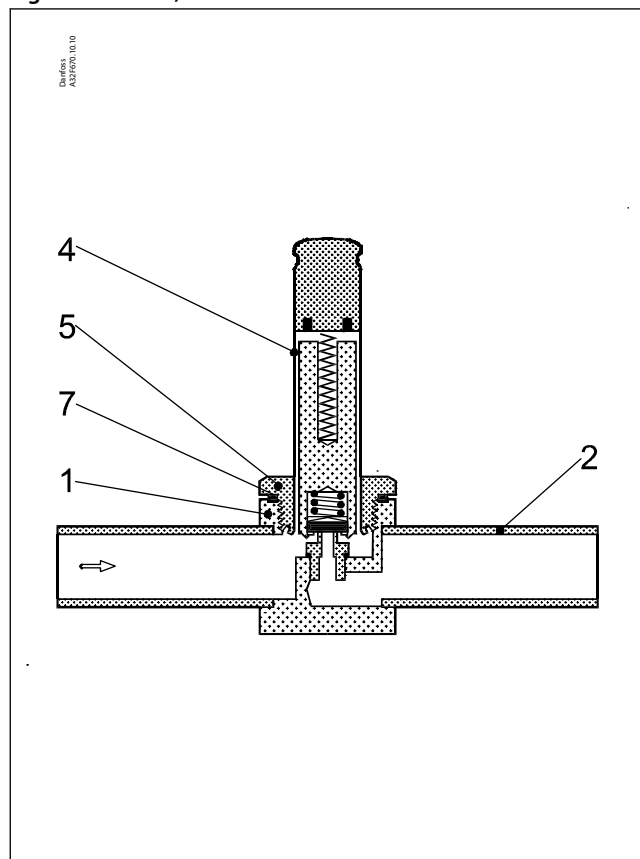

Figure 6: EVRS 3, welded



Solenoid valve, Type EVRS 3-20 and EVRST 10-20

Figure 7: EVRS/ EVRST 10 and 15

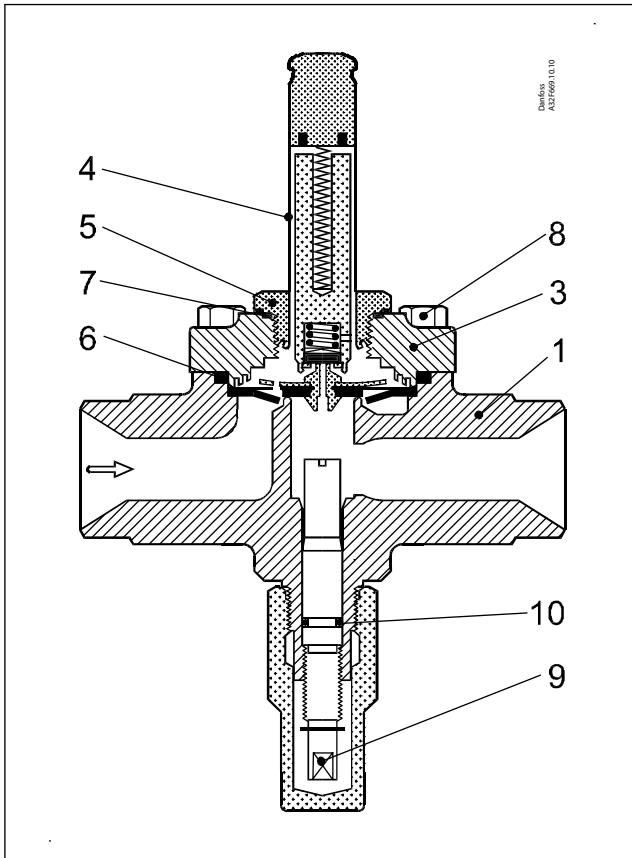

Figure 8: EVRS/ EVRST 20

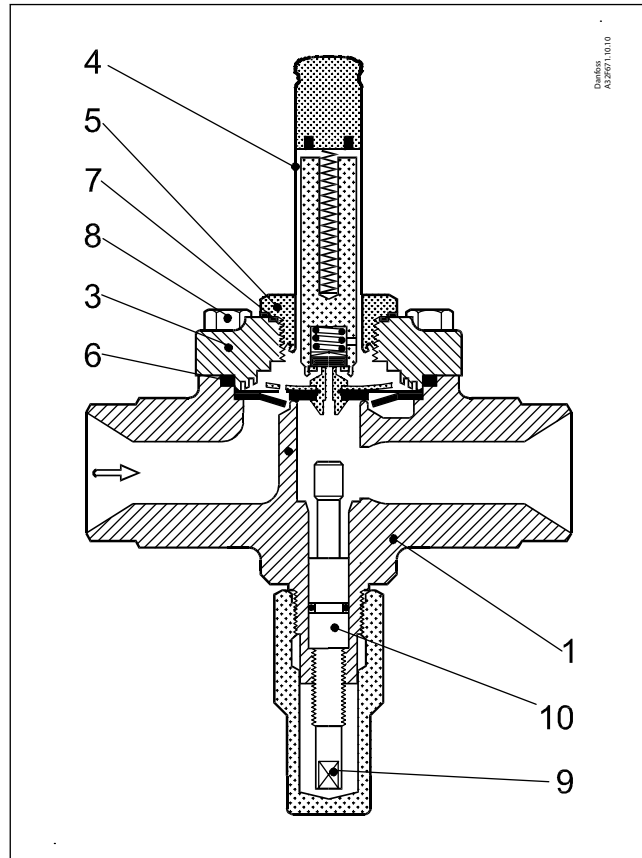

Table 29: Material specification

No.	Description	Solenoid valves				Standard		
		Type	Material	Analysis	Mat.no.	W.no.	DIN	EN
1	Valve housing	EVRS 3	Stainless steel	X8 CrNiS 18-9		1.4305		10088
		EVRS (T) 10/15/20	Stainless steel	X6 CrNi 18-9		1.4308	17455	
2	Welding tube	EVRS 3	Stainless steel	X2 CrNiMo 17-12-2		1.4404	17455	
3	Cover	EVRS (T) 10(15/20)	Stainless steel	X6 CrNi 18-9		1.4308	17455	
4	Armature tube	EVRS(T) 3/10/15/20	Stainless steel	X2 CrNi 19-11		1.4306		10088
5	Armature tube nut	EVRS(T) 3/10/15/20	Stainless steel	X8 CrNi 19-11		1.4305		10088
6	Gasket	EVRS(T) 3/10/15/20	Rubber	Cr				
7	Gasket armature tube	EVRS(T) 10/15/20	Al gasket	Al 99.5		3.0255		10210
8	Screws	EVRS(T) 10/15/20	Stainless steel	A2-70			3506	
9	Spindle for man. oper.	EVRS(T) 10/15/20	Stainless steel	X8 CrNiS 18-9		1.4305		10088
10	Gasket	EVRS(T) 10/15/20	Rubber	Cr				

## Dimensions and weights

Figure 9: EVRS 3, pipe thread

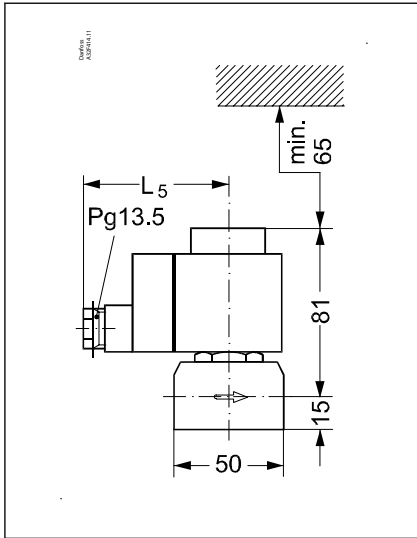

Figure 10: EVRS 3, weld

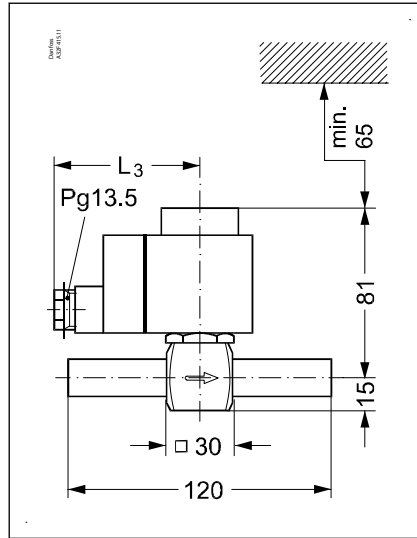

Figure 11: Coil with cable

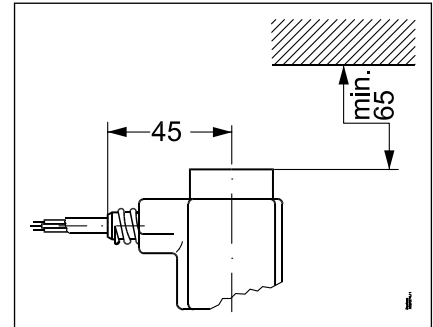

Figure 12: Coil with DIN plugs

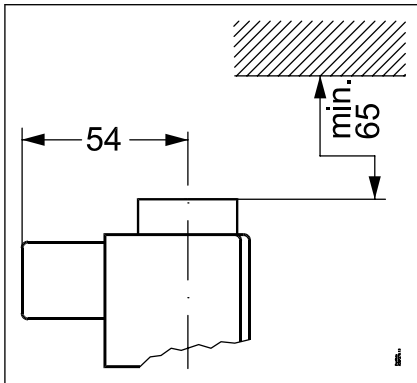

Figure 13: EVRS / EVRST 10 and 15  
Coil with terminal box

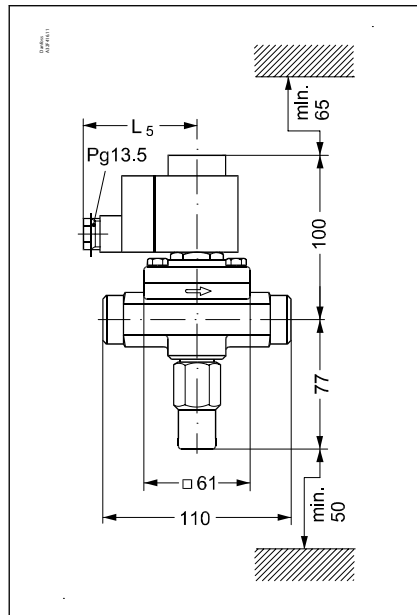
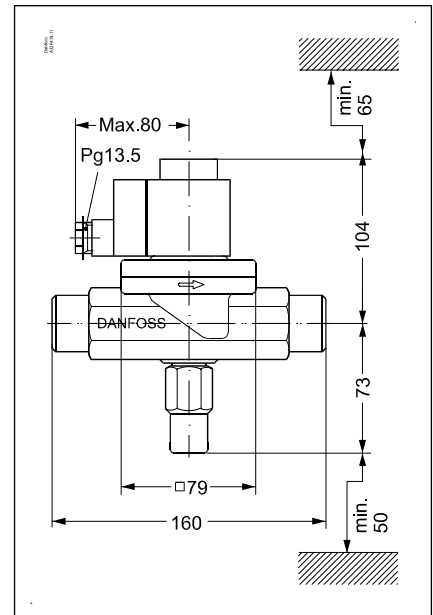

Figure 14: EVRS / EVRST 20 Coil with terminal box



**NOTE:**

Weight of coil:

- 10 W: approx. 0.3 kg
- 12 and 20 W: approx. 0.5 kg

Table 30: Weight of coil

Type	L <sub>3</sub> max.		Weight with coil kg
	10 W	12 W 20 W	
	mm	mm	
EVRS 3, pipe thread	75	85	0.7
EVRS 3, weld	75	85	0.6
EVRS/EVRST 10	75	85	1.2
EVRS/EVRST 15	75	85	1.3
EVRS/EVRST 20	75	85	2

## Solenoid valve, Type EVRS 3-20 and EVRST 10-20

---

**NOTE:**

Above weight is approximated.

## Ordering

Figure 15: Ordering

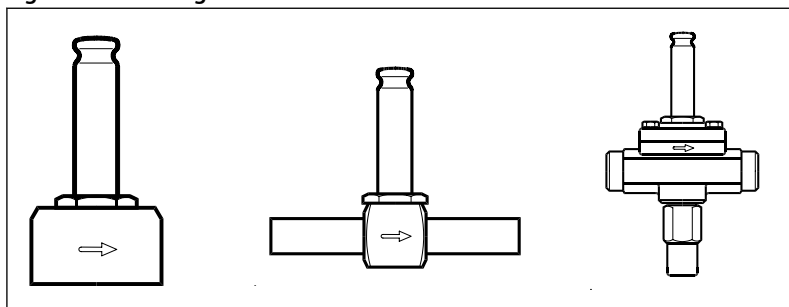

Table 31: Separate valve bodies

Type	Max. working pressure P <sub>s</sub> bar	Connection		Code no.	
		Weld in.	Pipe thread ISO 228/1	With manual stem	Without manual stem
EVRS 3	50	3/8			032F3080
EVRS 3	50		G 1/4		032F3081
EVRS 10	50	1/2		032F3082	
EVRST 10	50	1/2		032F3083	
EVRS 15	50	3/4		032F3084	
EVRST 15	50	3/4		032F3085	
EVRS 20	50	1		032F5437	
EVRST 20	50	1		032F5438	

Coils See "Coils for solenoid valves", data sheet. [AI237186440089](#)

## Certificates, declarations and approvals

The list contains all certificates, declarations, and approvals for this product type. Individual code number may have some or all of these approvals, and certain local approvals may not appear on the list.

Some approvals may change over time. You can check the most current status at [danfoss.com](http://danfoss.com) or contact your local Danfoss representative if you have any questions.

**Table 32: Valid approvals**

File name	Document type	Document topic	Approval authority
0C14029.523467890YTN	Pressure - Safety Certificate	CRN	TSSA

## Online support

Danfoss offers a wide range of support along with our products, including digital product information, software, mobile apps, and expert guidance. See the possibilities below.

### The Danfoss Product Store



The Danfoss Product Store is your one-stop shop for everything product related—no matter where you are in the world or what area of the cooling industry you work in. Get quick access to essential information like product specs, code numbers, technical documentation, certifications, accessories, and more.

Start browsing at [store.danfoss.com](https://store.danfoss.com).

### Find technical documentation



Find the technical documentation you need to get your project up and running. Get direct access to our official collection of data sheets, certificates and declarations, manuals and guides, 3D models and drawings, case stories, brochures, and much more.

Start searching now at [www.danfoss.com/en/service-and-support/documentation](https://www.danfoss.com/en/service-and-support/documentation).

### Danfoss Learning



Danfoss Learning is a free online learning platform. It features courses and materials specifically designed to help engineers, installers, service technicians, and wholesalers better understand the products, applications, industry topics, and trends that will help you do your job better.

Create your Danfoss Learning account for free at [www.danfoss.com/en/service-and-support/learning](https://www.danfoss.com/en/service-and-support/learning).

### Get local information and support



Local Danfoss websites are the main sources for help and information about our company and products. Find product availability, get the latest regional news, or connect with a nearby expert—all in your own language.

Find your local Danfoss website here: [www.danfoss.com/en/choose-region](https://www.danfoss.com/en/choose-region).

### Spare Parts



Get access to the Danfoss spare parts and service kit catalog right from your smartphone. The app contains a wide range of components for air conditioning and refrigeration applications, such as valves, strainers, pressure switches, and sensors.

Download the Spare Parts app for free at [www.danfoss.com/en/service-and-support/downloads](https://www.danfoss.com/en/service-and-support/downloads).

### Coolselector®2 - find the best components for you HVAC/R system



Coolselector®2 makes it easy for engineers, consultants, and designers to find and order the best components for refrigeration and air conditioning systems. Run calculations based on your operating conditions and then choose the best setup for your system design.

Download Coolselector®2 for free at [coolselector.danfoss.com](https://coolselector.danfoss.com).

Danfoss can accept no responsibility for possible errors in catalogues, brochures and other printed material. Danfoss reserves the right to alter its products without notice. This also applies to products already on order provided that such alterations can be made without subsequential changes being necessary in specifications already agreed. All trademarks in this material are property of the respective companies. Danfoss and the Danfoss logotype are trademarks of Danfoss A/S. All rights reserved.